



Photoelectric sensors
W2S-2, Photoelectric proximity sensor,
Background suppression

WTB2S-2P1030S13



Type > [WTB2S-2P1030S13](#)
Part No. > [1063814](#)



Illustration may differ

At a glance

- Sensing ranges of up to 150 mm
- Almost no black/white shift up to 60 mm
- Sensor with line-shaped light spot
- Sensor with laser-like focused light spots
- Precise background suppression that is immune to interference/crosstalk
- High-performance PinPoint 2.0 LED

Your benefits

- An ultra-compact design with the performance of large photoelectric proximity sensors offers new space-saving machine construction possibilities.
- Large variety of proximity sensors and operating concepts enable a wide range of application options
- Use in confined spaces: detection of small, flat parts thanks to high-quality background suppression and almost nonexistent black/white shift
- Remote access: models with IO-Link allow data to be easily accessed from the PLC
- High availability and long-term use in grippers thanks to flexible and rugged cable entry



Features

Sensor/detection principle:	Photoelectric proximity sensor, Background suppression
Dimensions (W x H x D):	7.7 mm x 21.8 mm x 13.5 mm
Housing design (light emission):	Rectangular
Sensing range:	3 mm ... 30 mm ¹⁾
Type of light:	Visible red light
Light source:	PinPoint LED ²⁾
Wave length:	640 nm
Light spot size (distance):	X Ø 3 mm (15 mm)
Background suppression typ. from:	38 mm

¹⁾ Object with 90 % reflectance (referred to standard white, DIN 5033) ²⁾ Average service life: 100,000 h at T_U = +25 °C

Mechanics/electronics

Supply voltage:	10 V DC ... 30 V DC ¹⁾
Ripple:	≤ 5 Vpp ²⁾
Current consumption:	≤ 20 mA ³⁾
Output type:	PNP

Switching mode:	Light switching
Output current I _{max} ..:	< 50 mA
Response time:	< 0.4 ms ⁴⁾
Switching frequency:	1,200 Hz ⁵⁾
Connection type:	Cable, 3-wire, 3.5 m ⁶⁾
Cable material:	PVC
Cable diameter:	Ø 3 mm
Circuit protection:::	A, B, D ^{7) 8) 9)}
IO-Link:	-
Special device:	✓
Optics material:	PMMA
Enclosure rating:	IP 67
Ambient operating temperature:	-25 °C ... +50 °C
Ambient storage temperature:	-40 °C ... +75 °C
Housing material:	ABS/PC, Plastic

1) Limit values 2) May not exceed or fall below U_v tolerances 3) Without load 4) Signal transit time with resistive load 5) With light/dark ratio 1:1 6) Do not bend below 0 °C 7) A = V_S connections reverse-polarity protected 8) B = output reverse-polarity protected 9) D = outputs overcurrent and short-circuit protected

Dimensional drawing

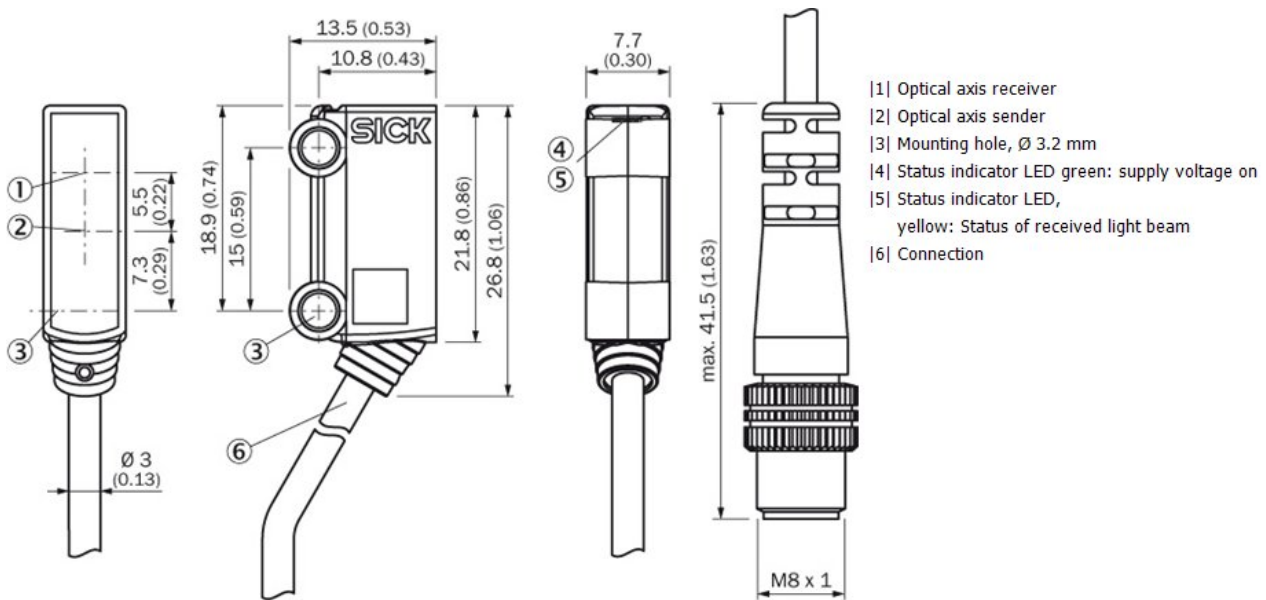

Connection diagram

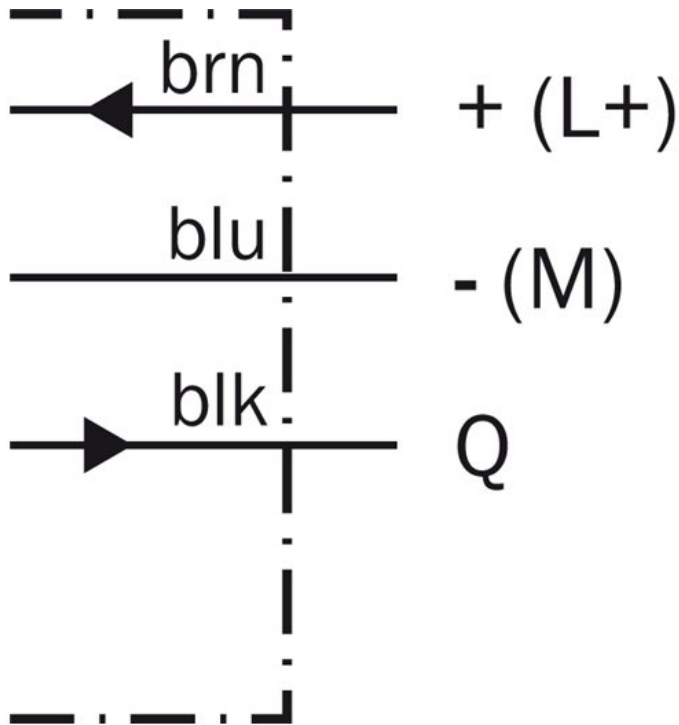

Light spot size

Spot diameter in mm (inch)

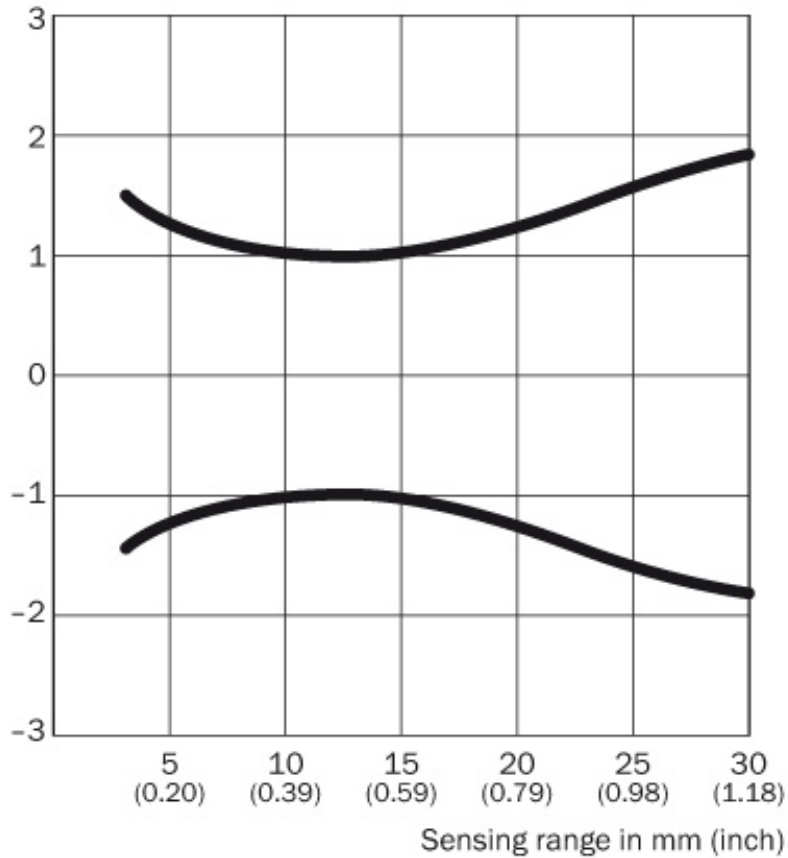

Dimensions in mm (inch)

Sensing range	Spot diameter
10 (0.39)	3.2 (0.13)
15 (0.59)	3.0 (0.12)
20 (0.79)	3.8 (0.15)
30 (1.18)	5.0 (0.20)

Sensing range diagram

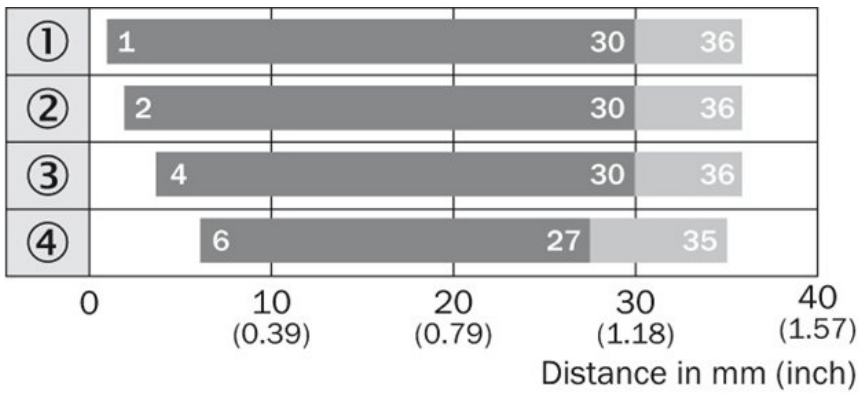

- |1| Sensing range on white, 90 % remission
- |2| Sensing range on gray, 18 % remission
- |3| Sensing range on black, 6 % remission
- |4| Sensing range on ultrablack, 1 % remission

■ Sensing range ■ Sensing range max.

Australia

Phone +61 3 9457 0600
1800 33 48 02 – tollfree
E-Mail sales@sick.com.au

Belgium/Luxembourg

Phone +32 (0)2 466 55 66
E-Mail info@sick.be

Brasil

Phone +55 11 3215-4900
E-Mail marketing@sick.com.br

Canada

Phone +1 905 771 14 44
E-Mail information@sick.com

Česká republika

Phone +420 2 57 91 18 50
E-Mail sick@sick.cz

China

Phone +86 4000 121 000
E-Mail info.china@sick.net.cn
Phone +852-2153 6300
E-Mail ghk@sick.com.hk

Danmark

Phone +45 45 82 64 00
E-Mail sick@sick.dk

Deutschland

Phone +49 211 5301-301
E-Mail info@sick.de

España

Phone +34 93 480 31 00
E-Mail info@sick.es

France

Phone +33 1 64 62 35 00
E-Mail info@sick.fr

Great Britain

Phone +44 (0)1727 831121
E-Mail info@sick.co.uk

India

Phone +91-22-4033 8333
E-Mail info@sick-india.com

Israel

Phone +972-4-6881000
E-Mail info@sick-sensors.com

Italia

Phone +39 02 27 43 41
E-Mail info@sick.it

Japan

Phone +81 (0)3 5309 2112
E-Mail support@sick.jp

Magyarország

Phone +36 1 371 2680
E-Mail office@sick.hu

Nederland

Phone +31 (0)30 229 25 44
E-Mail info@sick.nl

Norge

Phone +47 67 81 50 00
E-Mail sick@sick.no

Österreich

Phone +43 (0)22 36 62 28 8-0
E-Mail office@sick.at

Polska

Phone +48 22 837 40 50
E-Mail info@sick.pl

România

Phone +40 356 171 120
E-Mail office@sick.ro

Russia

Phone +7-495-775-05-30
E-Mail info@sick.ru

Schweiz

Phone +41 41 619 29 39
E-Mail contact@sick.ch

Singapore

Phone +65 6744 3732
E-Mail sales.gsg@sick.com

Slovenija

Phone +386 (0)1-47 69 990
E-Mail office@sick.si

South Africa

Phone +27 11 472 3733
E-Mail info@sickautomation.co.za

South Korea

Phone +82 2 786 6321/4
E-Mail info@sickkorea.net

Suomi

Phone +358-9-25 15 800
E-Mail sick@sick.fi

Sverige

Phone +46 10 110 10 00
E-Mail info@sick.se

Taiwan

Phone +886 2 2375-6288
E-Mail sales@sick.com.tw

Türkiye

Phone +90 (216) 528 50 00
E-Mail info@sick.com.tr

United Arab Emirates

Phone +971 (0) 4 88 65 878
E-Mail info@sick.ae

USA/México

Phone +1(952) 941-6780
1 (800) 325-7425 – tollfree
E-Mail info@sickusa.com

More representatives and agencies
at www.sick.com