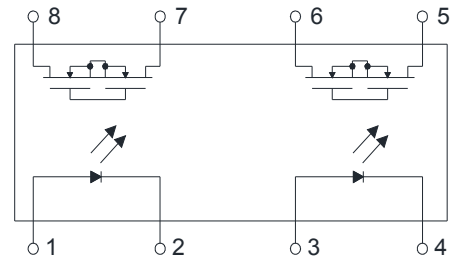


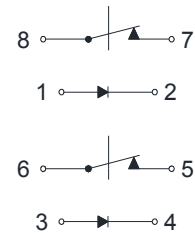
● Description

The KAQW412 series contains two normally close switches that can be used as two independent SPST relays or as one DPST relay. The relay is constructed using a GaAlAs LED for actuation control and an integrated monolithic dies for the switch output. The die, fabricated in a high-voltage dielectrically isolated technology, is comprised of a photodiode array, switch control circuitry and MOSFET switches.

● Schematic



DUAL 1 FORM B
NORMALLY CLOSE



● Features

1. Normally close, double pole single throw
2. Control 60V AC or DC voltage
3. Switch 200mA loads
4. Controls low-level analog signals
5. High sensitivity, low ON resistance
6. Low-level off-state leakage current
7. High isolation voltage 5KV (DIP/ SMD)
8. Pb free and RoHS compliant
9. MSL class 1
10. Agency Approvals :
 - UL Approved (No. E169586, E108430): UL1577, UL508
 - c-UL Approved (No. E169586, E108430)
 - VDE Approved (No. 40020973): DIN EN60747-5-5

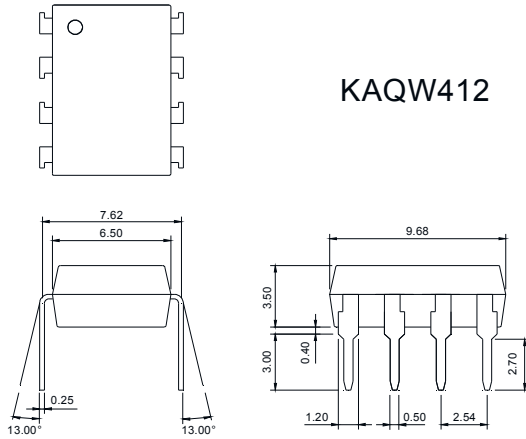
● Application

- Telecommunications (PC, electronic notepad)
- Modem
- Telephone equipment
- Security equipment
- Sensors
- Measuring and testing equipment
- Factory automation equipment
- High speed inspection machines

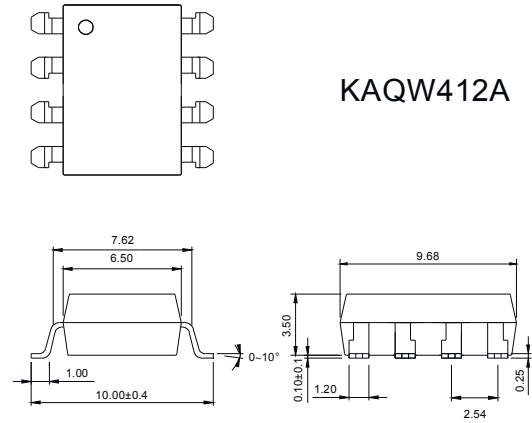
● **Outside Dimension**

Unit : mm

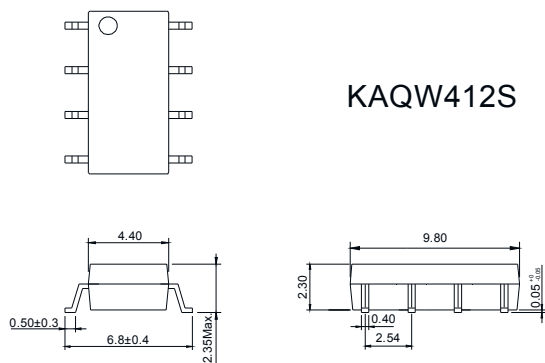
1. Dual-in-line type.



2. Surface mount type.

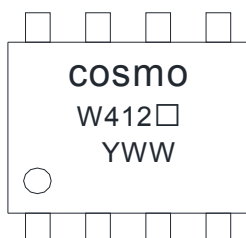


3. Small outline for surface mount type.



TOLERANCE : ±0.2mm

● **Device Marking**



Notes :

cosmo

W412□

YWW

□ : Pin forming

Y : Year code / W : Week code

● Absolute Maximum Ratings

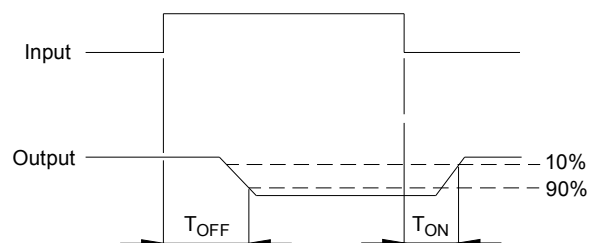
(Ta=25°C)

| Item | | Symbol | Rating | Unit |
|----------------------------------|----------------------------|-----------|-----------------|----------------|
| Input | Continuous forward current | I_F | 50 | mA |
| | Peak forward current | I_{FP} | 1 | A |
| | Reverse voltage | V_R | 5 | V |
| | Power dissipation | P_{in} | 100 | mW |
| | Derate linearly from 25°C | - | 1.3 | mW/°C |
| Output | Breakdown voltage | V_B | 60 | V |
| | Continuous load current | I_L | 200 | mA |
| | Power dissipation | P_{out} | 500 | mW |
| Isolation voltage | | V_{iso} | KAQW412S | KAQW412 |
| | | | 1500Vrms | 5000Vrms |
| Isolation resistance (Vio=500V) | | R_{iso} | $\geq 10^{10}$ | Ω |
| Total power dissipation | | P_t | 550 | mW |
| Derate linearly from 25°C | | - | 2.5 | mW/°C |
| Operating temperature | | T_{opr} | -40 to +85 | °C |
| Storage temperature | | T_{stg} | -40 to +125 | °C |
| Junction temperature | | T_j | 100 | °C |
| Soldering temperature 10 seconds | | T_{sot} | 260 | °C |

● Electro-optical Characteristics

(Ta=25°C)

| Parameter | | Symbol | Conditions | Min. | Typ. | Max. | Unit |
|--------------------|---------------------------|------------|----------------------------|------|------|------|----------|
| Input | Forward voltage | V_F | $I_F=10mA$ | - | 1.2 | 1.5 | V |
| | Operation input current | I_{FOFF} | $V_L=20V, I_L \leq 5\mu A$ | - | - | 3.0 | mA |
| | Recovery input current | I_{FON} | $V_L=20V, I_L=100mA$ | 0.2 | - | - | mA |
| Output | Breakdown voltage | V_B | $I_B=50\mu A, I_F=10mA$ | 60 | - | - | V |
| | Off-state leakage current | I_{LEAK} | $V_L=60V, I_F=5mA$ | - | 1.0 | 2.0 | μA |
| I/O capacitance | | C_{iso} | $V_B=0V, f=1MHz$ | - | 6 | - | pF |
| ON resistance | | R_{ON} | $I_F=0mA, I_L=100mA$ | - | 2.5 | 5 | Ω |
| Reverse (ON) time | | T_{ON} | $I_F=10mA, V_L=20V$ | - | 0.6 | 1.5 | ms |
| Operate (OFF) time | | T_{OFF} | $I_L=100mA, t=10ms$ | - | 0.3 | 1.5 | ms |

● Turn-on / Turn-off Time


● Schematic and Wiring Diagrams

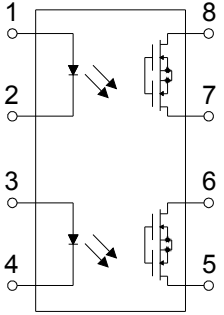
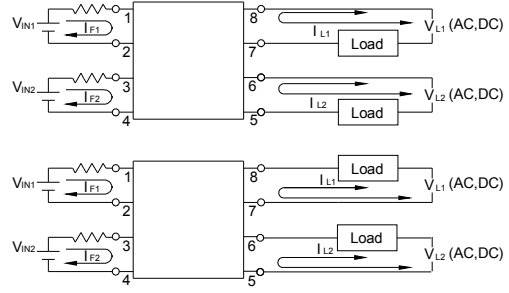
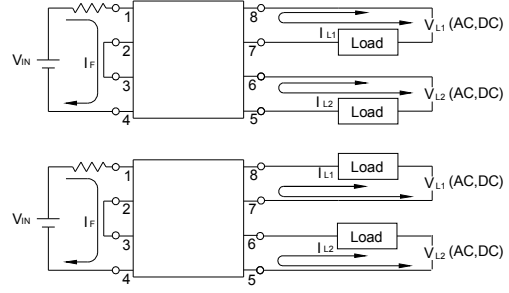
| Schematic | Output Configuration | Load | Connection | Wiring Diagrams |
|---|----------------------|----------|------------|--|
|  | 2b | AC DC | - | <p>(1) Two independent 1 Form B use</p>  <p>(2) 2 Form B use</p>  |

Fig.1 Load Current vs. Ambient Temperature

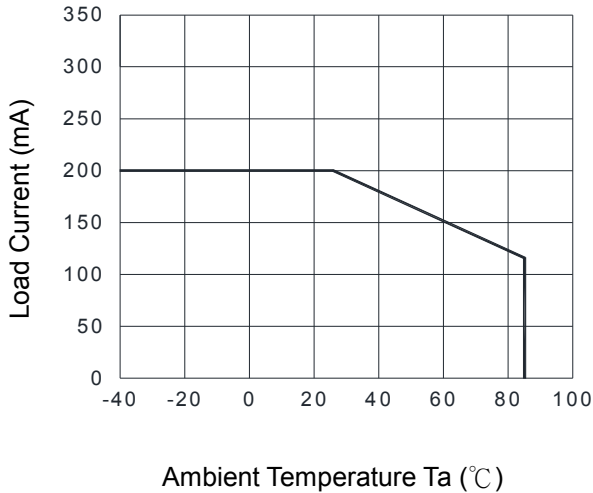


Fig.2 On Resistance vs. Ambient Temperature

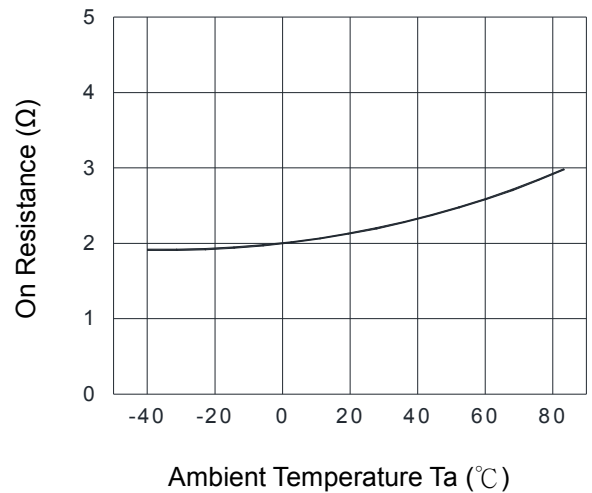


Fig.3 Operate (OFF) Time vs. Ambient Temperature

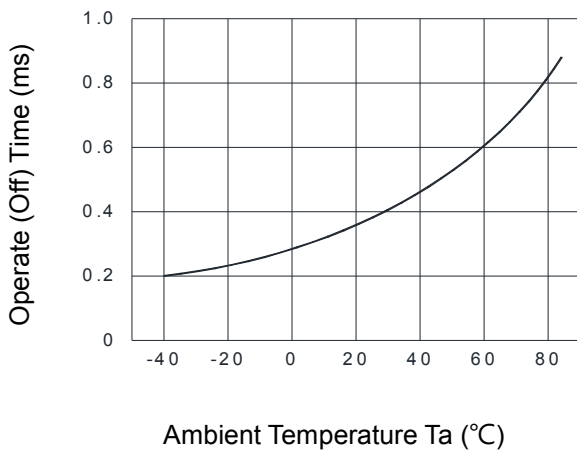


Fig.4 Reverse (ON) Time vs. Ambient Temperature

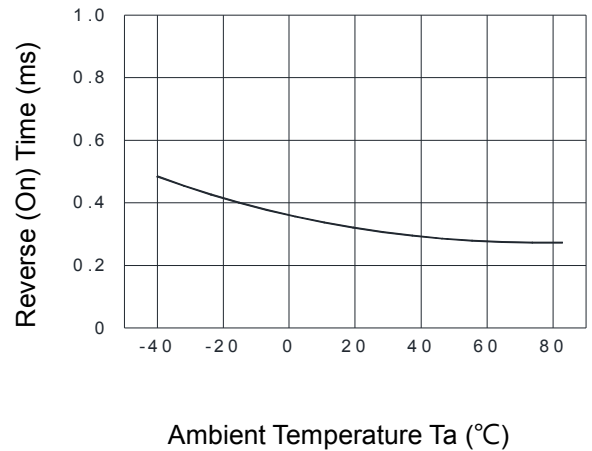


Fig.5 LED Operate Current vs. Ambient Temperature

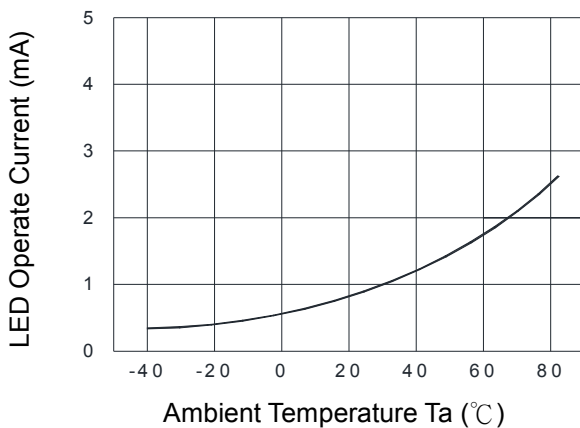


Fig.6 LED Turn-off Current vs. Ambient Temperature

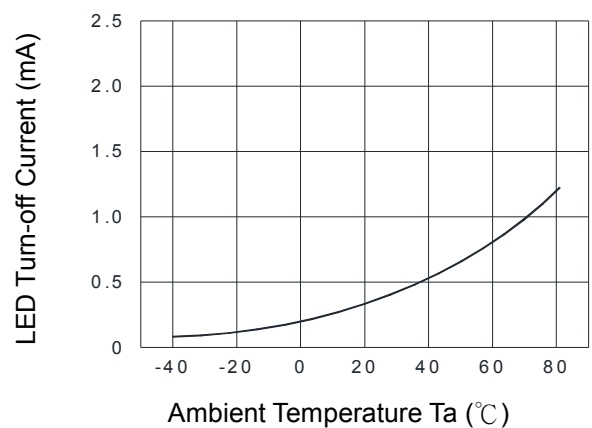


Fig.7 LED Dropout Voltage vs. Ambient Temperature

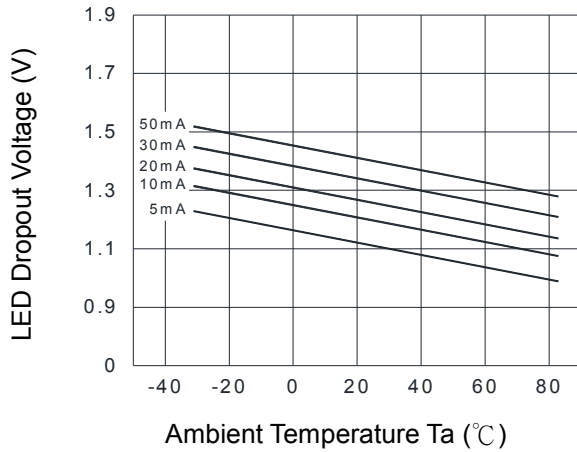


Fig.8 Voltage vs. Current Characteristics of Output at MOSFET Portion

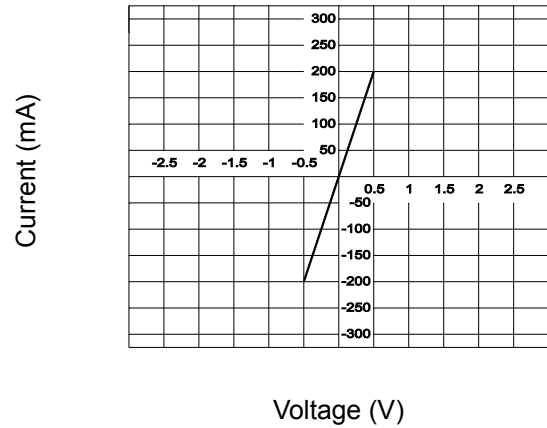


Fig.9 Operate (OFF) Time vs. LED Forward Current

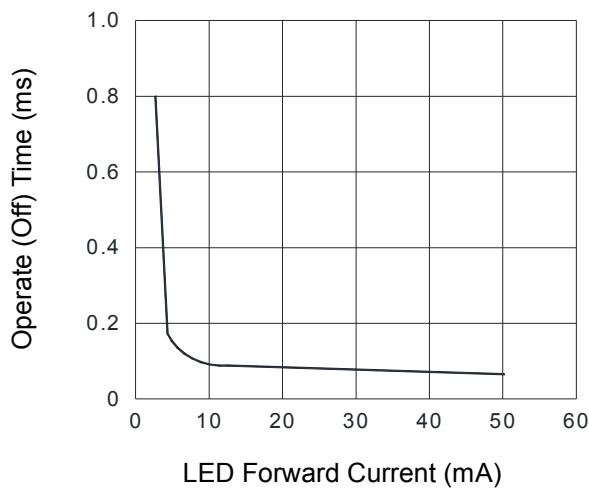


Fig.10 Off-state Leakage Current vs. Load Voltage

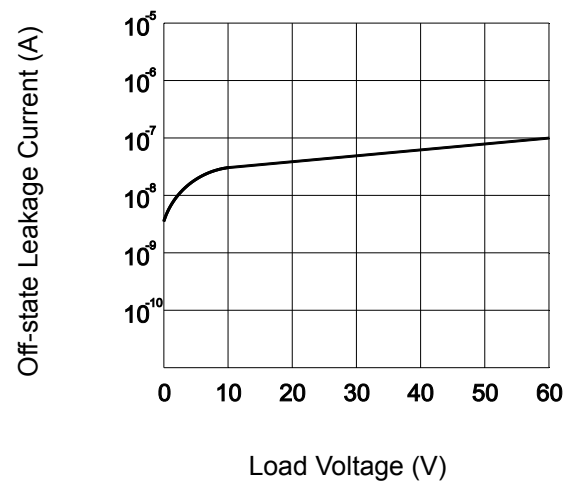


Fig.11 Reverse (ON) Time vs. LED Forward Current

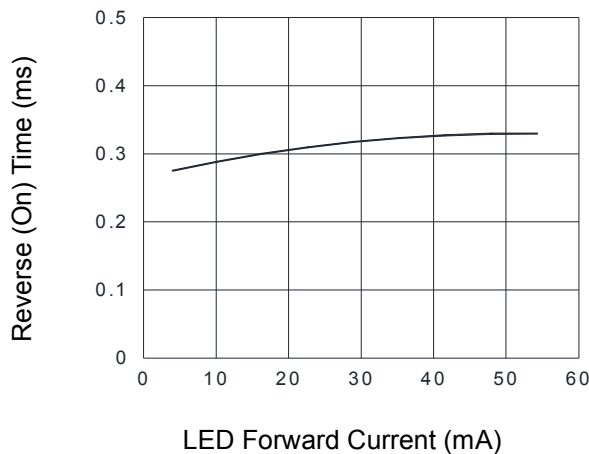
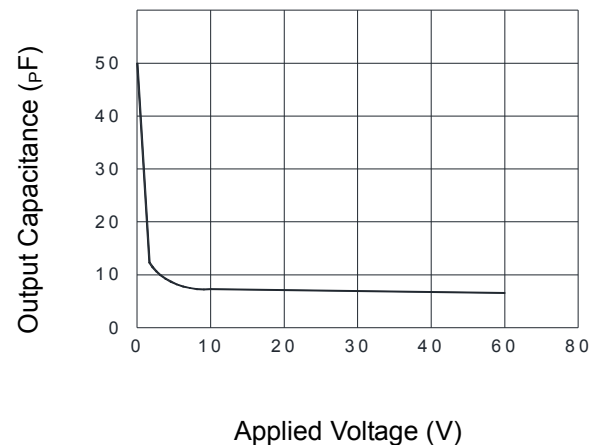
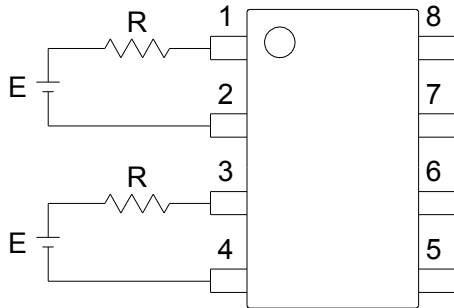


Fig.12 Output Capacitance vs. Applied Voltage



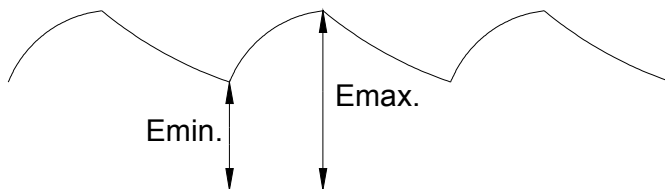
● Using Methods

Examples of resistance value to control LED forward current ($I_f=5\text{mA}$)

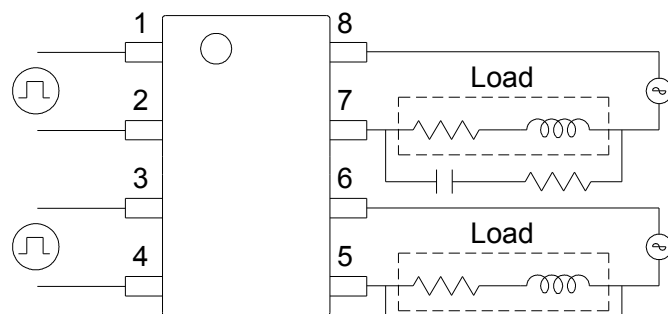
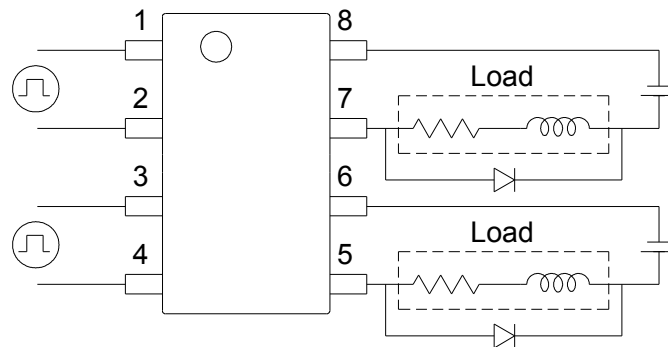


| E | R |
|------|-----------------------|
| 3.3V | Approx. 330 Ω |
| 5V | Approx. 640 Ω |
| 12V | Approx. 1.9K Ω |
| 15V | Approx. 2.5K Ω |
| 24V | Approx. 4.1K Ω |

1. LED forward current must be more than 5mA · at E min.
2. LED forward current must be less than 50mA · at E max.



Regulate the spike voltage generated on the inductive load as follows :



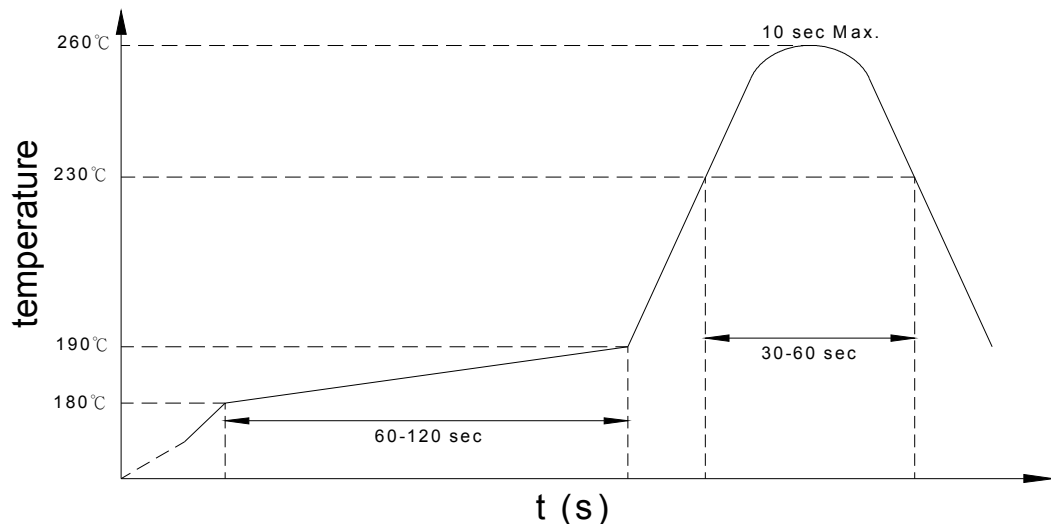
R-C Snubber

● **Recommended Soldering Conditions**

(a) Infrared reflow soldering :

- Peak reflow soldering : 260°C or below (package surface temperature)
- Time of peak reflow temperature: 10 sec
- Time of temperature higher than 230°C : 30-60 sec
- Time to preheat temperature from 180~190°C : 60-120 sec
- Number of reflows : Two
- Flux : Rosin flux containing small amount of chlorine (The flux with a maximum chlorine content of 0.2 Wt% is recommended.)

Recommended Temperature Profile of Infrared Reflow



(b) Wave soldering :

- Temperature : 260°C or below (molten solder temperature)
- Time : 10 seconds or less
- Preheating conditions: 120°C or below (package surface temperature)
- Number of times : One
- Flux : Rosin flux containing small amount of chlorine (The flux with a maximum chlorine content of 0.2 Wt% is recommended.)

(c) Cautions :

- Fluxes : Avoid removing the residual flux with freon-based and chlorine-based cleaning solvent.
- Avoid shorting between portion of frame and leads.

● **Numbering System**

KAQW412 X (Y)

Note :

KAQW412 = Part No.

X = Lead form option (blank 、 S or A)

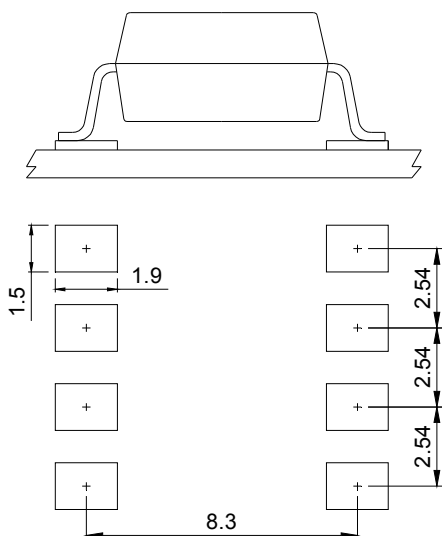
Y = Tape and reel option (TL 、 TR)

| Option | Description | Packing quantity |
|--------|--|---------------------|
| A (TL) | surface mount type package + TL tape & reel option | 1000 units per reel |
| A (TR) | surface mount type package + TR tape & reel option | 1000 units per reel |
| S (TL) | small outline for surface mount type package + TL tape & reel option | 2000 units per reel |
| S (TR) | small outline for surface mount type package + TR tape & reel option | 2000 units per reel |

● **Recommended Pad Layout for Surface Mount Lead Form**

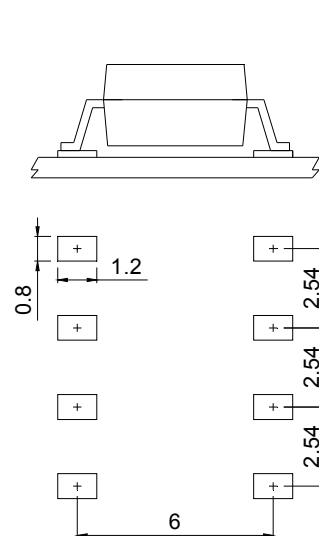
1. Surface mount type.

8-pin SMD



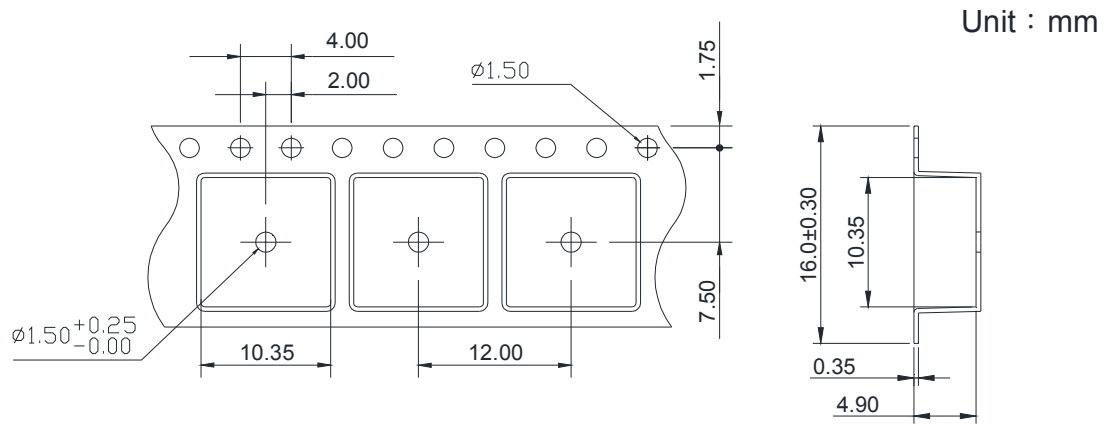
2. Small outline for surface mount type.

8-pin SOP

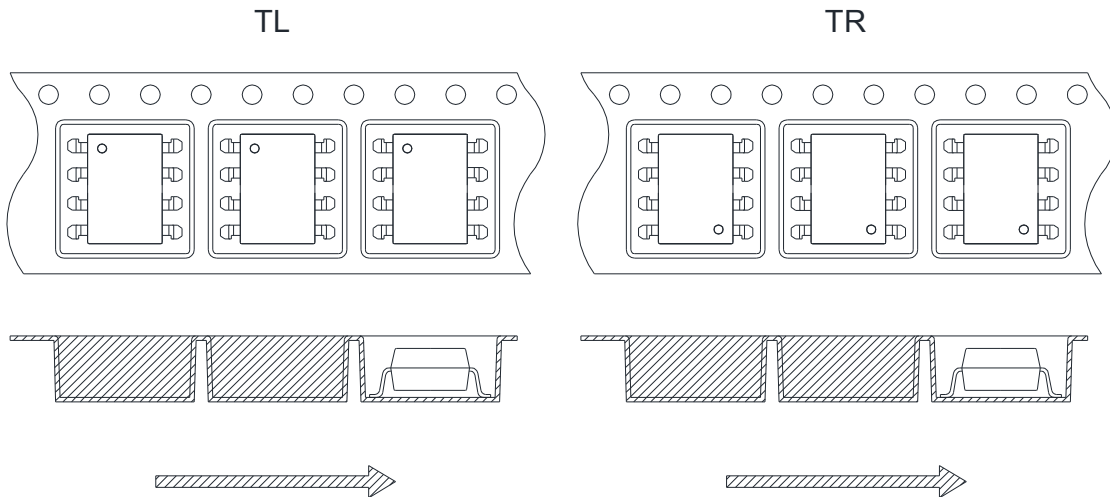


Unit : mm

● 8-pin SMD Carrier Tape & Reel

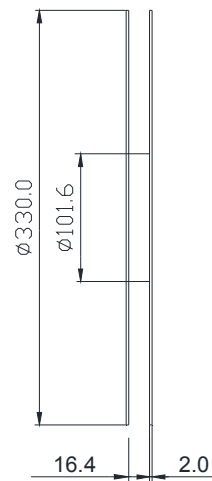
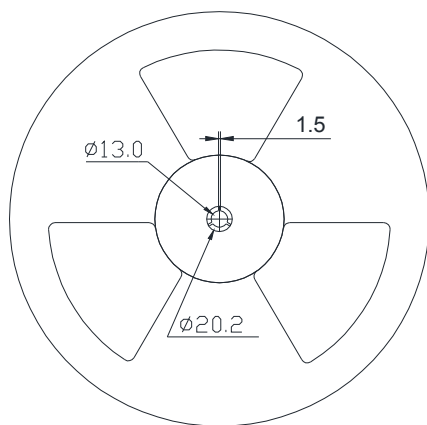


TOLERANCE : ± 0.2 mm

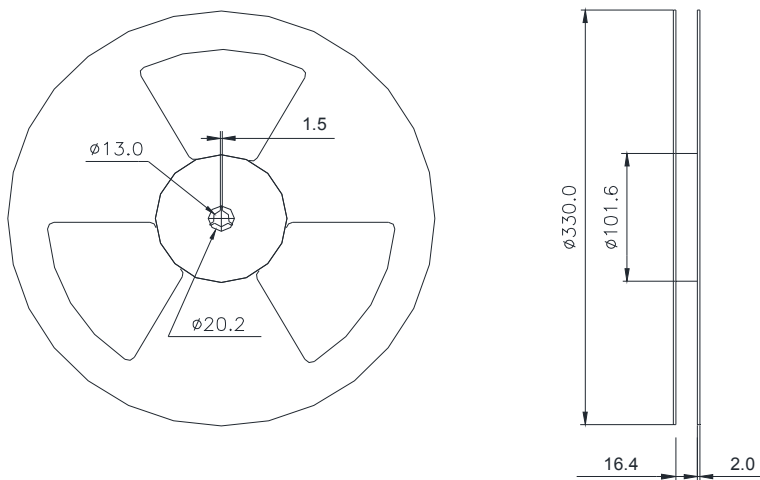
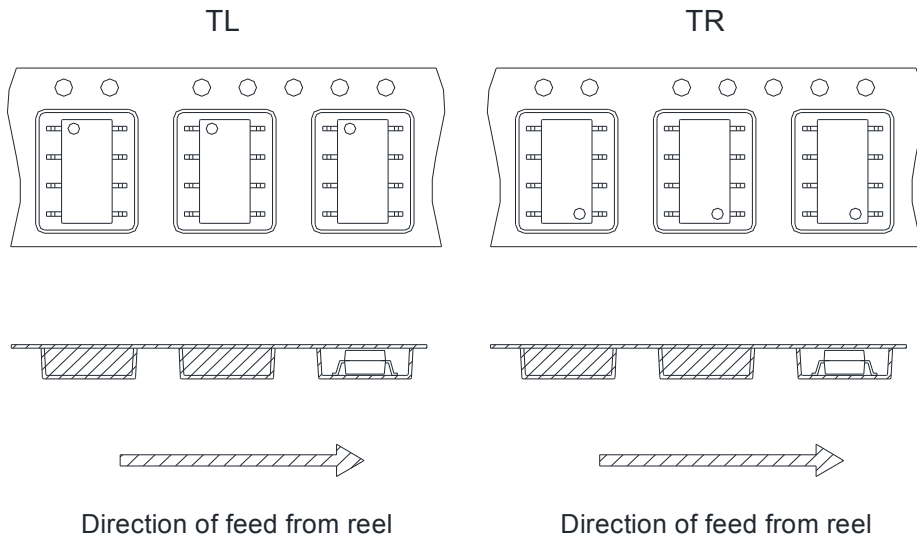
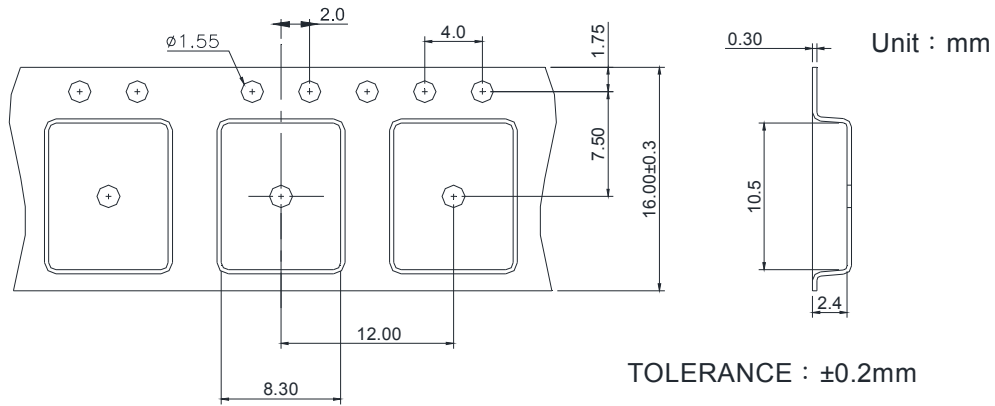


Direction of feed from reel

Direction of feed from reel



● 8-pin SOP Carrier Tape & Reel





KAQW412 Series

8PIN 60V N.C. TYPE

SOLID STATE RELAY-MOSFET OUTPUT

● Application Notice

The content of datasheet is the guidance for product use only. cosmo takes no responsibility to the accuracy of the information provided here. For continuously improving all of products, including quality, reliability, function...etc., cosmo reserves the right to change the specification, characteristics, data, materials, and structure of products without notice. Please contact with cosmo to obtain the latest specification.

It would be required to comply with the absolute maximum ratings listed in the specification. cosmo has no liability and responsibility to the damage caused by improper use of the products.

cosmo products are intended to be designed for use in general electronics application list below:

- a. Personal computer
- b. OA machine
- c. Audio / Video
- d. Instrumentation
- e. Electrical application
- f. Measurement equipment
- g. Consumer electronics
- h. Telecommunication

cosmo devices shall not be used or related with equipment requiring higher level of quality / reliability, or malfunction, or failure which may cause loss of human life, bodily injury, includes, without limitation:

- a. Medical and other life supporting equipments
- b. Space application
- c. Telecommunication equipment (trunk lines)
- d. Nuclear power control
- e. Equipment used for automotive vehicles, trains, ships...etc.

This publication is the property of cosmo. No part of this publication may be reproduced or copied in any form or any means electronically or mechanically for any purpose, in whole or in part without any written permission expressed from cosmo.