

	6	30	36.2	38	39.9	41	34.2	11.6g	21
	5	25	31.2	33	34.9	36	29.2	10.3g	18
	4	20	26.2	28	29.9	31	15.5	9.0g	15
	3	15	21.2	23	24.9	26	10.5	7.7g	12
	2	10	16.2	18	19.9	21	5.5	6.3g	9
	1	5	11.2	13	14.9	16	4.5	4.9g	6
M1:1	n	b	c ^{+0.1} _{-0.3}	d ^{+0.4} _{-0.3}	e ^{+0.2} _{-0.5}	f	g±0.25	WEIGHT Gewicht	NUMBER OF WAYS Polzahl

PRE-LOCKED AND FINAL POSITION
 Vorrast- und Endraststellung

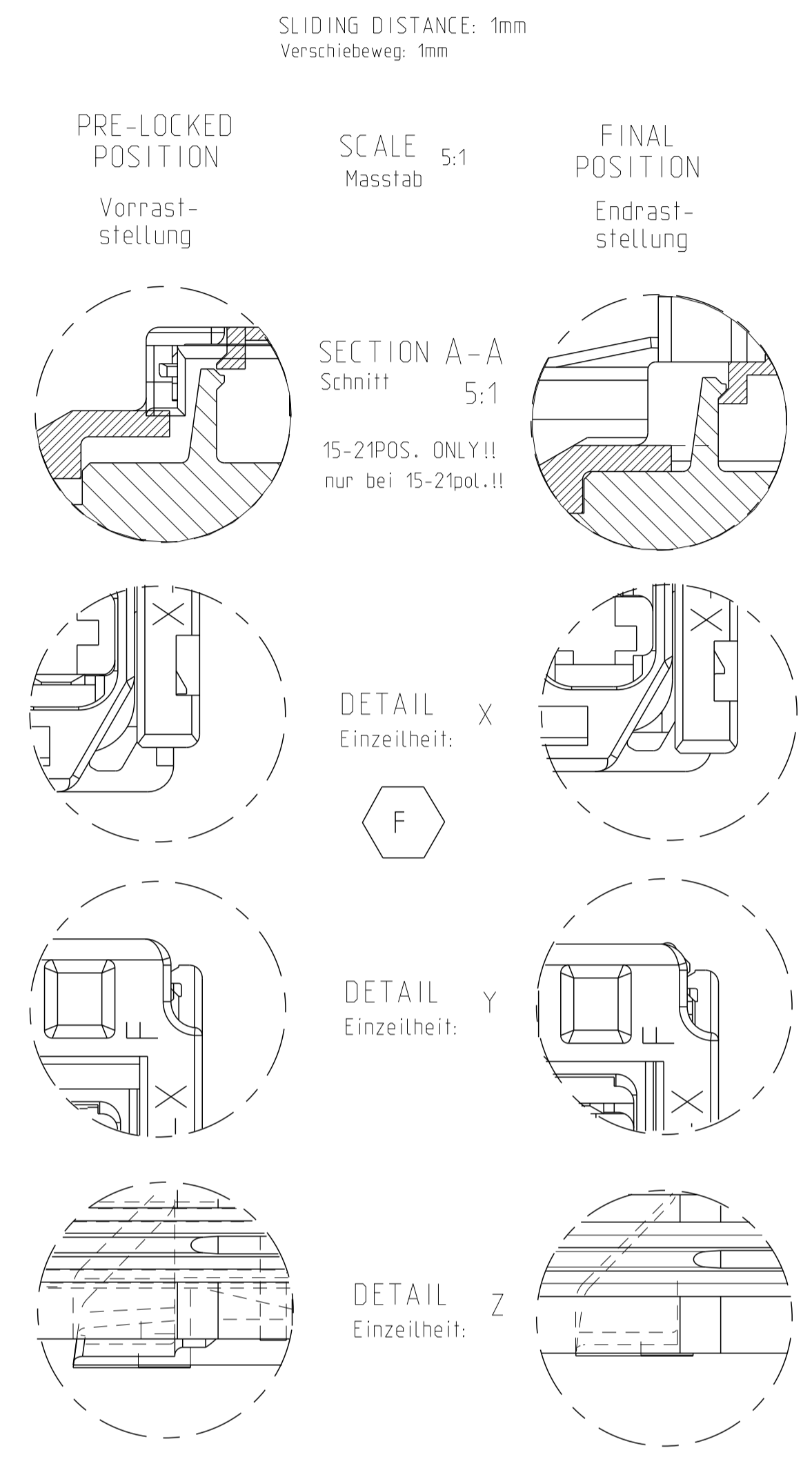

- NOTES
 Bemerkungen
- MATING CONNECTOR FOR AMP MCP 2.8 HOUSING
 SEE DRAWINGS 1355072 (TAB HOUSINGS),
 1964562 (TAB HOUSINGS),
 966140 (TAB HEADER),
 114-18085-025 (INTERFACE-DRAWING)
 Gegenstecker fuer AMP MCP 2.8 Gehaeuse
 siehe Zeichnungen 1355072 (Flachstecker-Gehaeuse),
 1964562 (Flachstecker-Gehaeuse),
 966140 (Messeleisten),
 114-18085-025 (Ausfuehrungsvorschrift)
 - CAVITIES MATING WITH AMP MCP 2.8 CONTACTS
 (WITHOUT SWS. MAX. WIRE SIZE: 2.5mm² FLR) -
 SEE PRODUCT GROUP DRAWING: 1355036
 Kontaktkammern passend fuer AMP MCP 2.8 Kontakte
 (ohne EDS. max. Leitungsquerschnitt: 2.5mm² FLR)
 - siehe Produktgruppenzeichnung : 1355036
 - DESIGN DEPENDS ON NUMBER OF WAYS
 Aussehen je nach Polzahl unterschiedlich
 - WARPAGE TO ... PERMITTED
 Verzug bis ... zulaessig
 - MOULD CAVITY-MARKING = X
 SERIAL MOULD-NUMBER = n. (if n>1 only)
 Nestmarkierung = X
 Serienwerkzeug-Nr. = n (nur wenn n>1)
 - MATERIAL-MARKING ACC. TO VDA 260
 Werkstoffkennzeichnung nach
 - CAVITY-MARKING
 Kammerbezeichnung
 - THE REVISION STATUS OF THE MOULD
 Aenderungszustand des Werkzeuges
 - TE PARTNUMBER
 TE Bestell-Nr. Teil
 - WARPAGE TO 11.3 PERMITTED
 Verzug bis 11.3 zulaessig
 - PRODUCTION-DATE
 Produktionsdatum
 - PACKAGING: BULK PACKAGING IN CORRUGATED BOX -
 INDICATED BY PRE-DASH-NO.s 8-, 7-, 6-, 5-;
 THESE PRE-DASH-NO.s ARE ON PART NOW:
 Verpackung: Schuetttgut in Versandkarton -
 gekennzeichnet durch Vorstrichzahlen 8-, 7-, 6-, 5-;
 diese Vorstrichzahlen sind jetzt auch am Teil!
 - MALFUNCTION CAUSED BY LACQUER IS NOT
 COVERED BY TE WARRANTY
 Funktionbeeintraechtigung durch Lackieren liegt
 nicht im Einfluss und Gewaehrleistungsumfang von TE
 - COMPANY LOGO
 Firmenzeichen

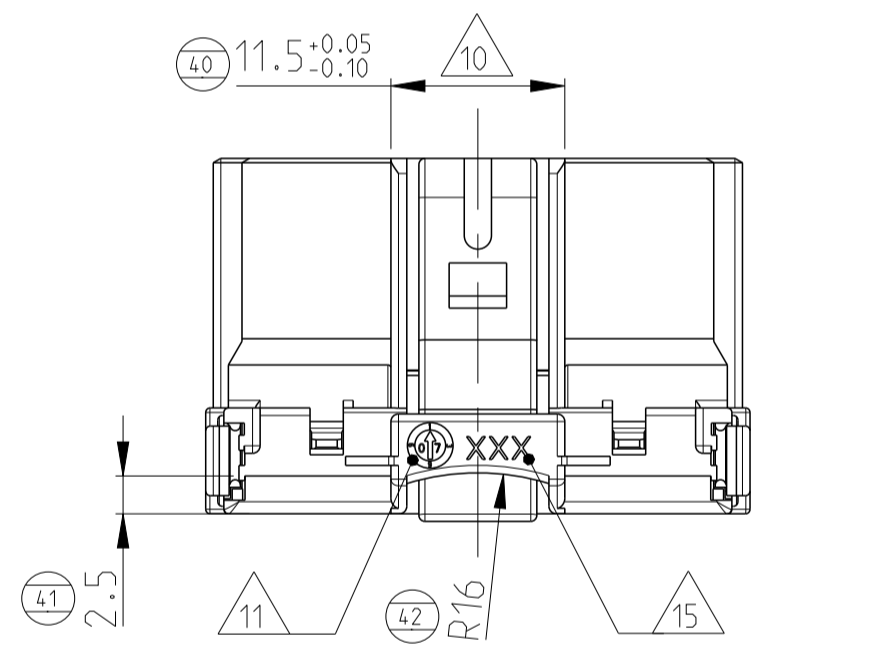
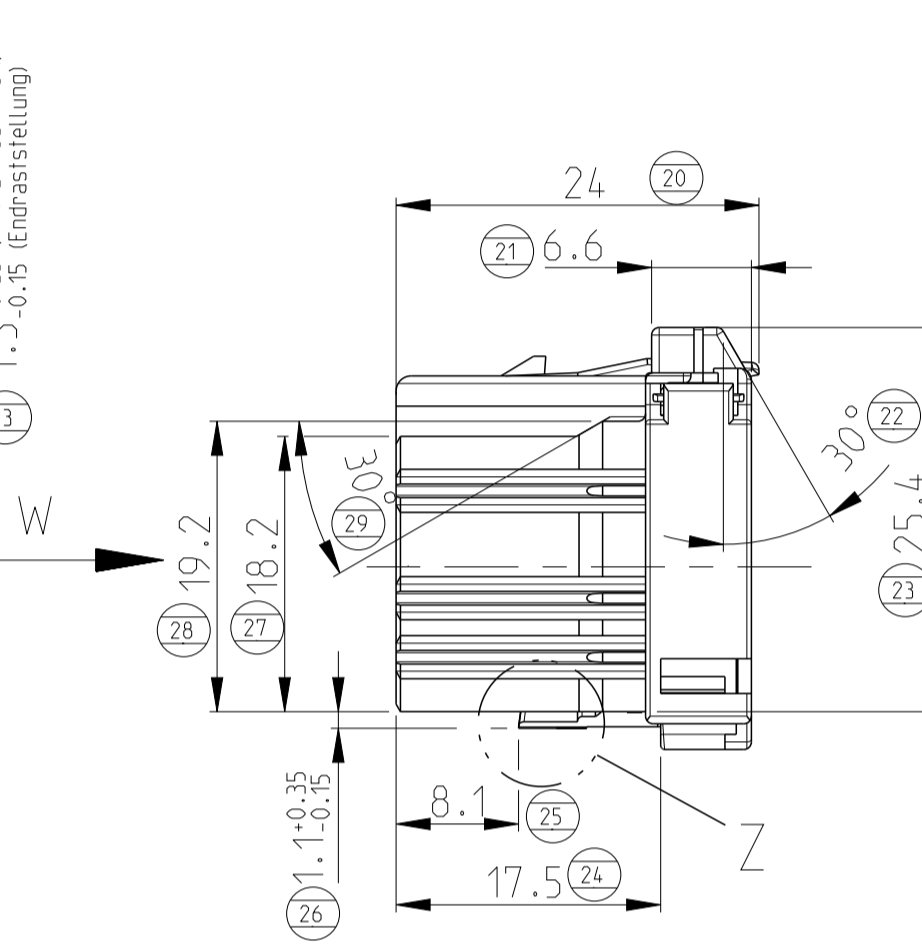
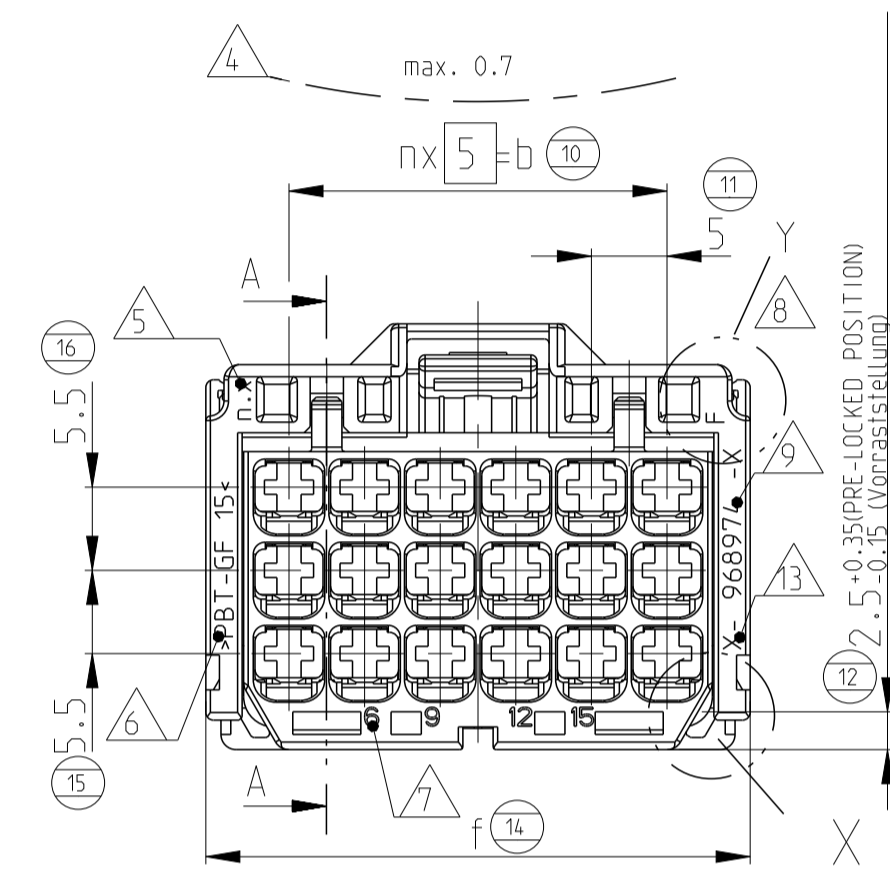
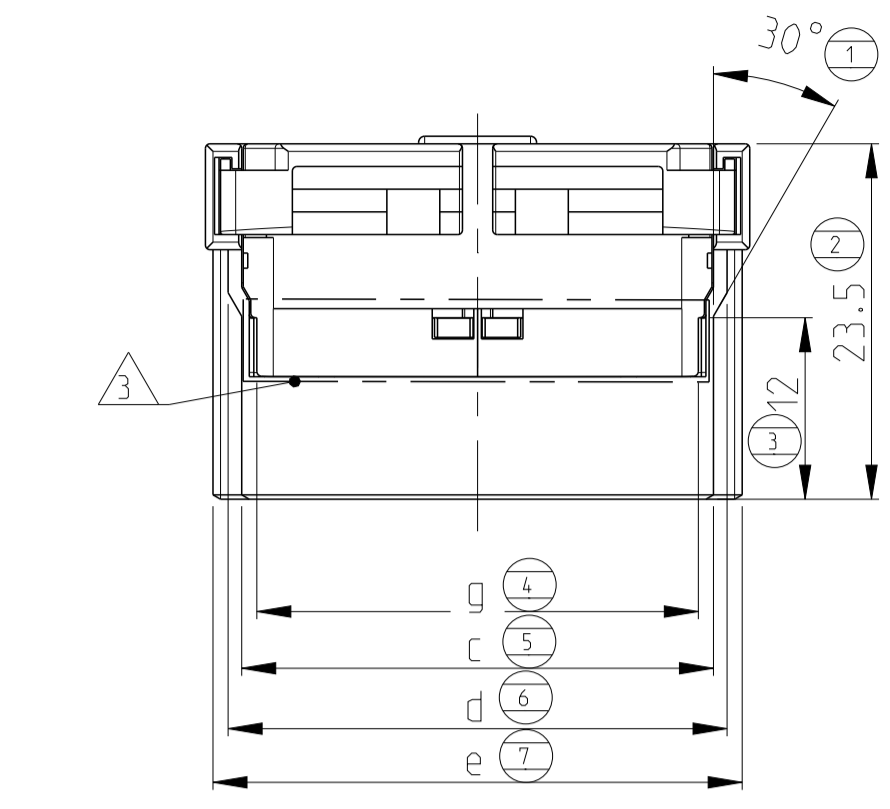

8-968974-1 AS SHOWN IN PRE-LOCKED POSITION
 wie gezeichnet in Vorraststellung

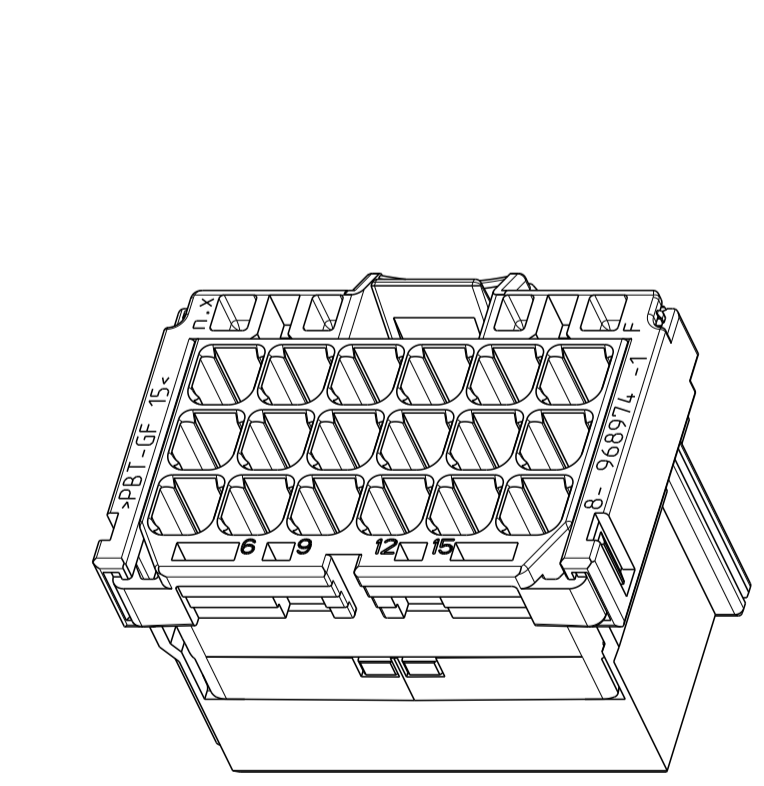

3D-MODEL (18POS.; CODING A)
 2:1

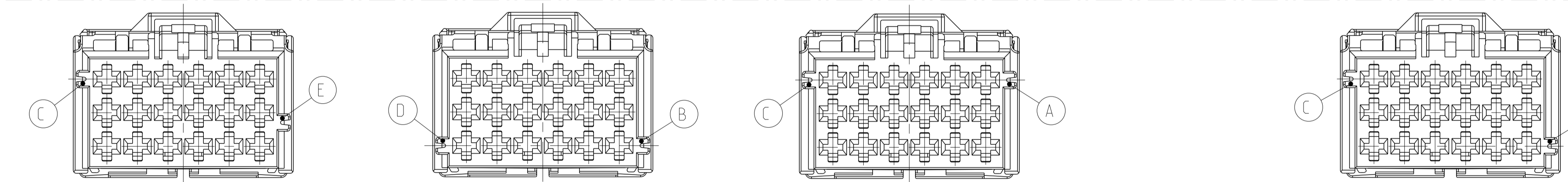

CODING / Kodierung D RIB / Rippe: C-E				CODING / Kodierung C RIB / Rippe: B-D				CODING / Kodierung B RIB / Rippe: A-C				CODING / Kodierung A RIB / Rippe: B-C				MECHAN. CODING mechan. Kodierung											
	5-968975-1	F	CLARET VIOLET Bordeauxviolett		6-968975-1	F	LIGHT BLUE Lichtblau		7-968975-1	F	NATURE natur		8-968975-2	F	GREY grau		8-968975-1	F	BROWN braun	1	21	POS. polig	AMP MCP 2.8 HOUSING AMP MCP 2.8 Gehaeuse	PBT-GF 15			
	5-968974-1	F			6-968974-1	F			7-968974-1	F						-	-	-		8-968974-1	F	GREY grau			1	18	POS. polig
	5-968973-1	F			6-968973-1	F			7-968973-1	F						8-968973-2	F	GREY grau		8-968973-1	F	VIOLET violett			1	15	POS. polig
	5-968972-1	F			6-968972-1	F			7-968972-1	F						8-968972-2	F	GREY grau		8-968972-1	F	GREEN gruen			1	12	POS. polig
	5-968971-1	F			6-968971-1	F			7-968971-1	F						8-968971-2	F	GREY grau		8-968971-1	F	YELLOW gelb			1	9	POS. polig
	5-968970-1	F			6-968970-1	F			7-968970-1	F						8-968970-2	F	GREY grau		8-968970-1	F	GENTIAN BLUE Enzianblau			1	6	POS. polig
CUSTOMER PART NO. Kunden-Teile-Nr.	TE ORDER-NO. TE Bestell-Nr.	REV	COLOUR Farbe	CUSTOMER PART NO. Kunden-Teile-Nr.	TE ORDER-NO. TE Bestell-Nr.	REV	COLOUR Farbe	CUSTOMER PART NO. Kunden-Teile-Nr.	TE ORDER-NO. TE Bestell-Nr.	REV	COLOUR Farbe	CUSTOMER PART NO. Kunden-Teile-Nr.	TE ORDER-NO. TE Bestell-Nr.	REV	COLOUR Farbe	CUSTOMER PART NO. Kunden-Teile-Nr.	TE ORDER-NO. TE Bestell-Nr.	REV	COLOUR Farbe	POS.	DESCRIPTION Benennung Einzelteil	MATERIAL Werkstoff					

THIS DRAWING IS A CONTROLLED DOCUMENT.

APPROVED: R. Huebner, 19JAN1998
 CHK: J. Hass, 19JAN1998
 APVD: M. Bleicher, 18JAN2008

DIMENSIONS: mm
 TOLERANCES UNLESS OTHERWISE SPECIFIED:
 0 PLC ±
 1 PLC ±
 2 PLC ±
 3 PLC ±
 4 PLC ±
 ANGLES ±0.1°
 FINISH SEE PARTS LIST

WEIGHT: SEE TABLE
 CUSTOMER DRAWING

NAME: PRODUCT GROUP DRAWING FOR: AMP MCP 2.8 HSG.
 6-21POS. WITH SECONDARY LOCKING DEVICE
 Produkt-Gruppen-Zeichnung fuer: AMP MCP 2.8 Gehaeuse.
 6-21polig mit zweiter Kontaktsicherung

SIZE: 108-18619-3
 APPLICATION SPEC: 114-94624

SCALE: 2:1
 SHEET: 1 OF 2
 REV: F

MATED WITH / PASSEND ZU:		PROJEKT NR. A97-52046	LOC A1	DIST -	REVISIONS			
P.	LTN.	DESCRIPTION	DATE	DMN	APVD			
-	-	SEE SHEET 1	-	-	-			

ADDITIONAL CODINGS / Zusätzliche Kodierungen

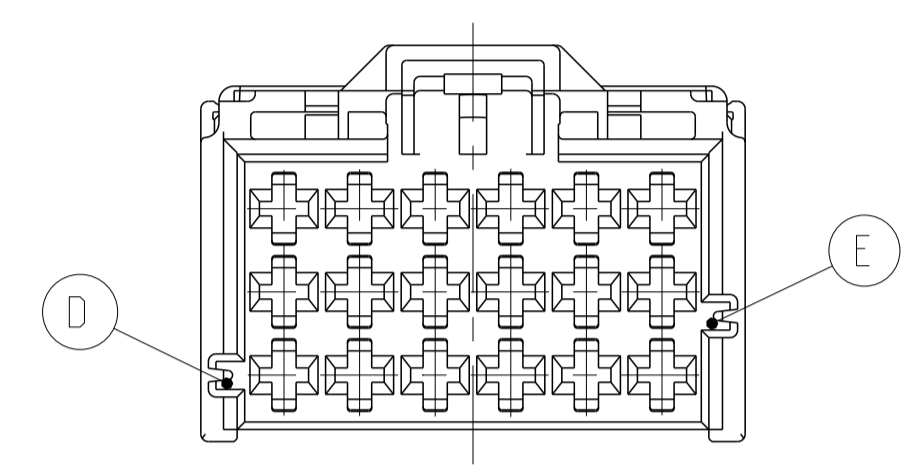
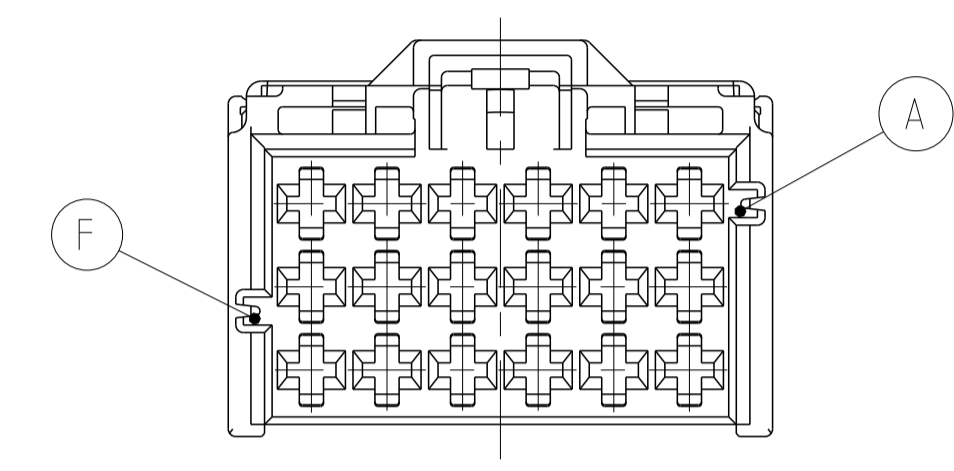

CODING / Kodierung F			MECHANICAL CODING: mechanische Kodierung:	
RIBS / Nuten: A-F				
9-968975-2	F		21 POS. pol.	PBT-GF15
9-968974-2	F		18 POS. pol.	
			15 POS. pol.	
9-968972-2	F	ORANGE	12 POS. pol.	
			9 POS. pol.	
9-968970-2	F		6 POS. pol.	
CUSTOMER PART NUMBER Kunden-Einzelteil-Nummer	TE ORDER-NO. TE Bestell-Nr.	REV.	DESCRIPTION Benennung Einzelteil	MATERIAL Werkstoff

F

CODING / Kodierung E			MECHANICAL CODING: mechanische Kodierung:	
RIBS / Nuten: E-D				
4-968975-1	F		21 POS. pol.	PBT-GF15
4-968974-1	F		18 POS. pol.	
			15 POS. pol.	
4-968972-1	F	EMERALD GREEN	12 POS. pol.	
			9 POS. pol.	
4-968970-1	F		6 POS. pol.	
CUSTOMER PART NUMBER Kunden-Einzelteil-Nummer	TE ORDER-NO. TE Bestell-Nr.	REV.	DESCRIPTION Benennung Einzelteil	MATERIAL Werkstoff

F

THIS DRAWING IS A CONTROLLED DOCUMENT.		DMN R. Huebner CHK J. Haas	19JAN1998 19JAN1998	STE TE Connectivity
DIMENSIONS: mm		APVD M. Bleicher	18JAN2008	
TOLERANCES UNLESS OTHERWISE SPECIFIED: mm 0 PLC ±0.10 1 PLC ±0.15 2 PLC ±0.20 3 PLC ±0.25 4 PLC ±0.30 ANGLES ±2°		NAME PRODUCT GROUP DRAWING FOR: AMP MCP 2.8 HSG. 6-21POS. WITH SECONDARY LOCKING DEVICE Produkt-Gruppen-Zeichnung fuer: AMP MCP 2.8 Gehaeuse. 6-21polig mit zweiter Kontaktsicherung		RESTRICTED TO
MATERIAL SEE PARTS LIST		FINISH SEE PARTS LIST	WEIGHT SEE TABLE	
CUSTOMER DRAWING		SIZE A1	CAGE CODE 00779	DRAWING NO. C=1355073
SCALE 2:1		SHEET 2	OF 2	REV F