

1A Low Dropout Positive Voltage Regulator

PL5033-XXXFP3

Features

- Adjustable or Fixed Output
- Output Current of 1A
- Low Dropout, 1.4V max at 1A Output Current
- Good Noise Rejection
- Output Current Limiting
- Built-in Thermal Shutdown
- Fast Transient Response

Description

The PL5033 series of positive adjustable and fixed regulators are designed to provide 1A with high efficiency. All internal circuitry is designed to operate down to 1.4V input to output differential. The product is specifically designed to provide well-regulated supply for low-voltage IC application such as high-speed bus termination and low current 3.3V logic supply, and other applications such as VGA cards.

Applications

- High Efficiency Linear Regulators
- Post Regulators for Switching Supplies
- Adjustable Power Supply

Typical Application Data

Fixed Voltage Regulator

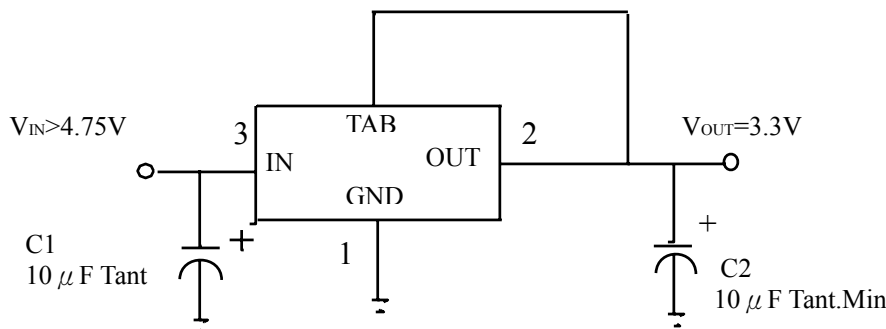

Adjustable Voltage Regulator

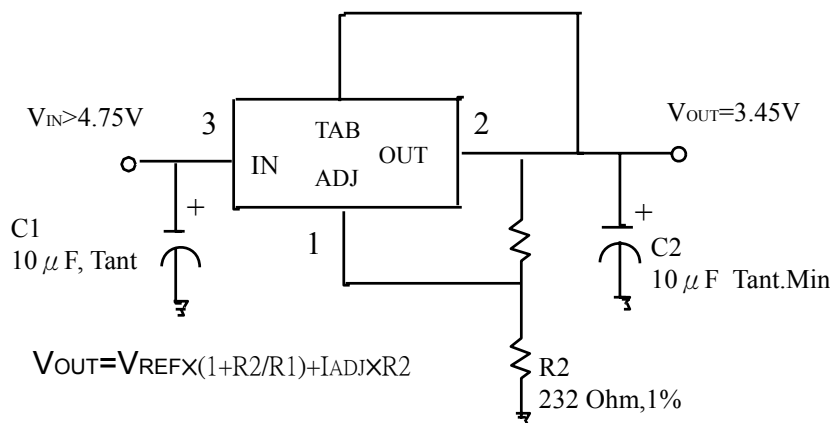

Notes:

- 1) C1 needed if device is far from filter capacitors
- 2) C2 minimum value required for stability

Package Information

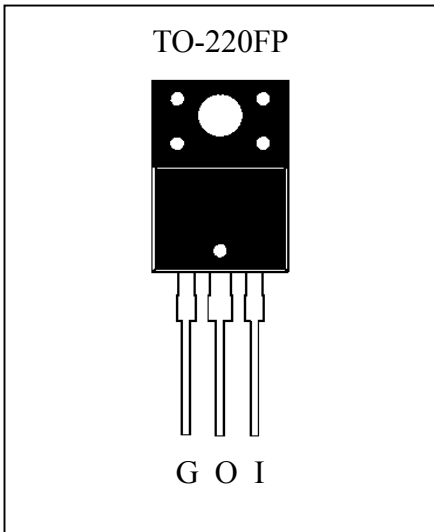

Pin	Name
1	ADJ/GND
2	OUTPUT
3	INPUT

Absolute Maximum Ratings

Symbol	Parameter	Ratings	Units
P _D	Power Dissipation	Internally Limited	W
V _{IN}	Input Voltage	-0.3 ~ +15	V
T _{OPR}	Operating Junction Temperature Range	0 ~ +125	°C
T _{STG}	Storage Temperature	-65 ~ +150	°C
T _{MJ}	Maximum Junction Temperature	150	°C

Device Selection Guide

Device	Output Voltage
PL5033-ADJ	Adjustable
PL5033-1.5	1.5V
PL5033-1.8	1.8V
PL5033-2.5	2.5V
PL5033-3.3	3.3V
PL5033-5.0	5.0V

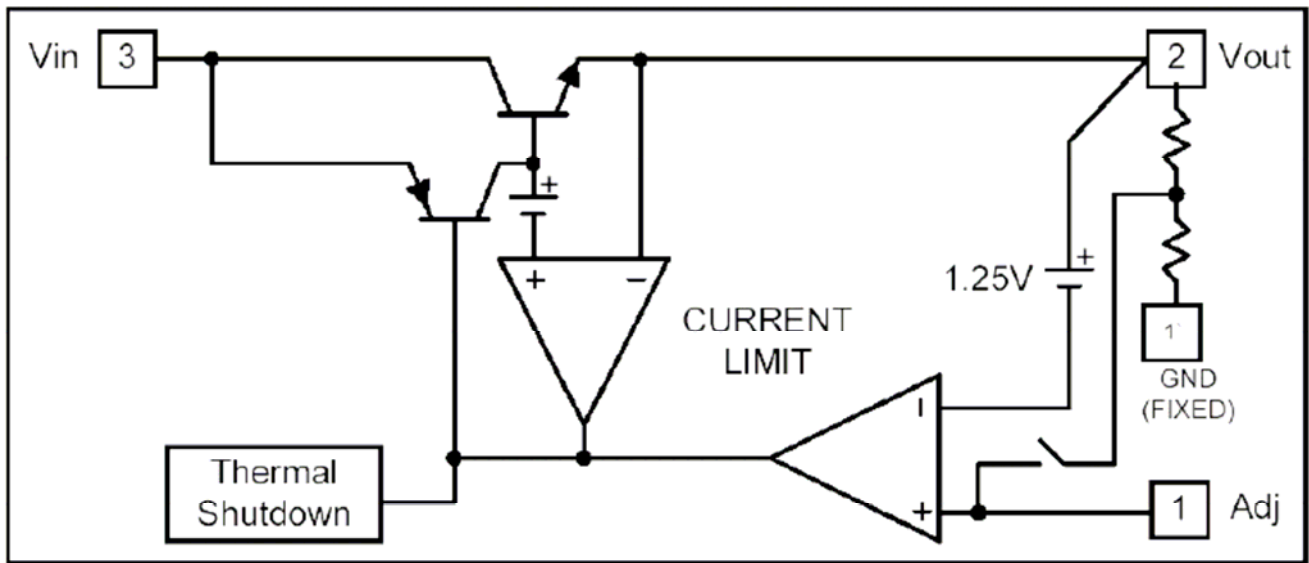
Block Diagram

Electrical Characteristics @ $I_o=10\text{mA}$, $T_J=25^\circ\text{C}$, unless otherwise specified

Parameter	Device	Test Conditions	Min	Typ	Max	Units
Reference voltage	Adj version	$V_{IN}-V_{OUT}=1.5\text{V}$	1.225	1.250	1.275	V
Output Voltage	PL5033-1.5	$3.0\text{V} \leq V_{IN} \leq 12\text{V}$	1.470	1.500	1.530	V
	PL5033-1.8	$3.3\text{V} \leq V_{IN} \leq 12\text{V}$	1.764	1.800	1.836	V
	PL5033-2.5	$4.0\text{V} \leq V_{IN} \leq 12\text{V}$	2.450	2.500	2.550	V
	PL5033-3.3	$4.8\text{V} \leq V_{IN} \leq 12\text{V}$	3.235	3.300	3.365	V
	PL5033-5.0	$6.5\text{V} \leq V_{IN} \leq 12\text{V}$	4.900	5.000	5.100	V
Line Regulation	All version	$V_{OUT}+1.5\text{V} \leq V_{IN} \leq 12\text{V}$	-	-	0.2	%
Load Regulation (Note 1, 2)	PL5033-ADJ	$V_{IN}=3.3\text{V}$, $V_{adj}=0$, $10\text{mA} \leq I_o \leq 1\text{A}$	-	-	1	%
	PL5033-1.5	$V_{IN}=3.0\text{V}$, $0\text{mA} \leq I_o \leq 1\text{A}$	-	12	15	mV
	PL5033-1.8	$V_{IN}=3.3\text{V}$, $0\text{mA} \leq I_o \leq 1\text{A}$	-	15	18	mV
	PL5033-2.5	$V_{IN}=4.0\text{V}$, $0\text{mA} \leq I_o \leq 1\text{A}$	-	20	25	mV
	PL5033-3.3	$V_{IN}=5.0\text{V}$, $0\text{mA} \leq I_o \leq 1\text{A}$	-	26	33	mV
	PL5033-5.0	$V_{IN}=8.0\text{V}$, $0\text{mA} \leq I_o \leq 1\text{A}$	-	40	50	mV
Dropout Voltage ($V_{IN}-V_{OUT}$)	All version	$I_o=0.1\text{A}$, $V_{in}=V_{out}+1.3\text{V}$	-	1.06	1.2	V
		$I_o=0.5\text{A}$, $V_{in}=V_{out}+1.3\text{V}$	-	1.16	1.25	V
		$I_o=1.0\text{A}$, $V_{in}=V_{out}+1.3\text{V}$	-	1.24	1.4	V
Current Limit	All version	$V_{IN}-V_{OUT}=5\text{V}$	1.1	-	-	A
Minimum Load Current	Adj version	$V_{IN}=5\text{V}$	-	5	10	mA
Adjust Pin Current	Adj version	$V_{IN}=12\text{V}$, $I_o=10\text{mA}$	-	50	100	μA
Quiescent Current	Fixed version	$V_{IN}=12\text{V}$, $I_o=0\text{mA}$	-	-	12	mA



Thermal Regulation	All version	$T_A=25^{\circ}\text{C}$, 30ms pulse	-	0.008	0.04	%/W
Ripple Rejection	All version	$f=120\text{Hz}$, $V_{IN}=V_{OUT}+3\text{V}$, $I_O=1\text{A}$, $C_{OUT}=25\mu\text{F}$ tantalum	-	60	70	dB
Temperature Stability	All version	$I_O=10\text{mA}$	-	0.5	-	%
Thermal Resistance, Junction to Ambient(No heat sink, no air flow)	All version	No heat sink, no air flow	-	98	-	$^{\circ}\text{C}/\text{W}$
Thermal Resistance, Junction to Case	All version	Control Circuitry/ Power transistor	-	15	-	$^{\circ}\text{C}/\text{W}$

- Note : 1. See thermal regulation specifications for changes in output voltage due to heating effects. Line and load regulation are measured at a constant junction temperature by low duty cycle pulse testing. Load regulation is measured at the output lead 1/18" from the package.
2. Line and load regulation are guaranteed up to the maximum power dissipation of 15W. Power dissipation is determined by the difference in input and output and the output current. Guaranteed maximum power dissipation will not be available over the full input/output range.

Characteristic Curves

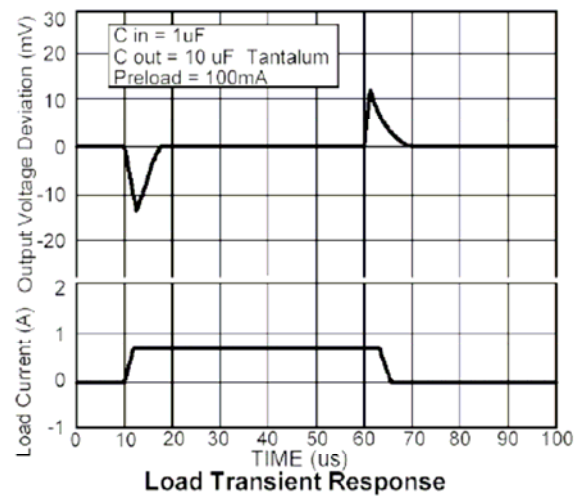
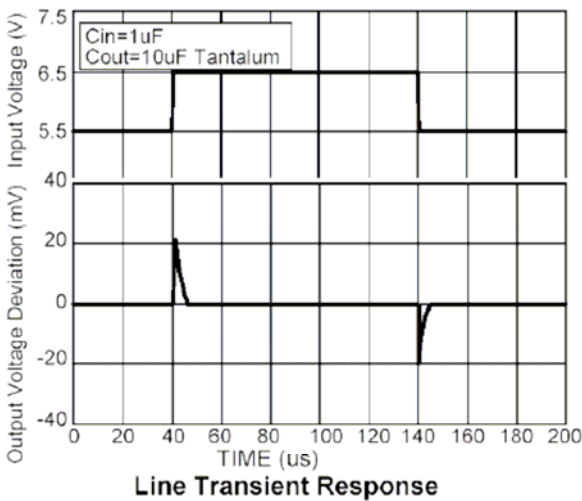
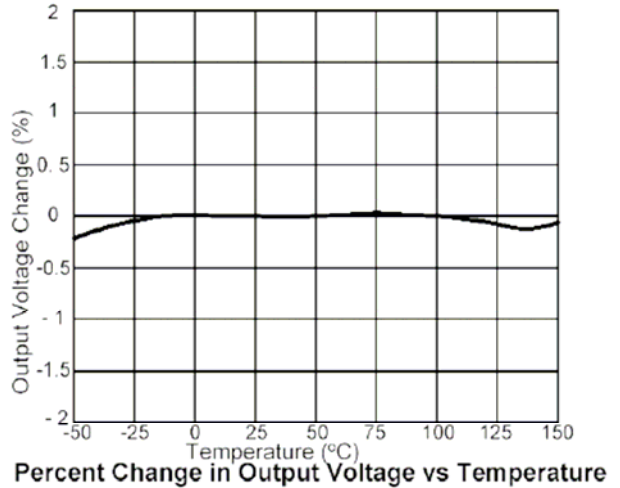
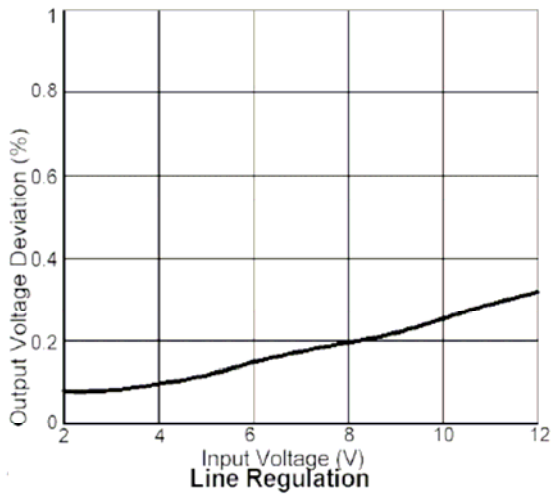
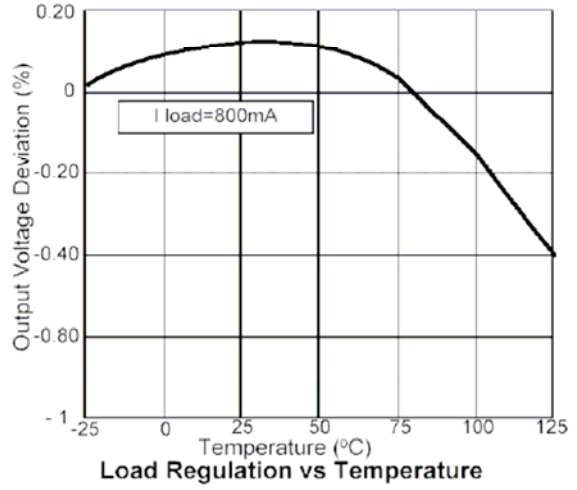
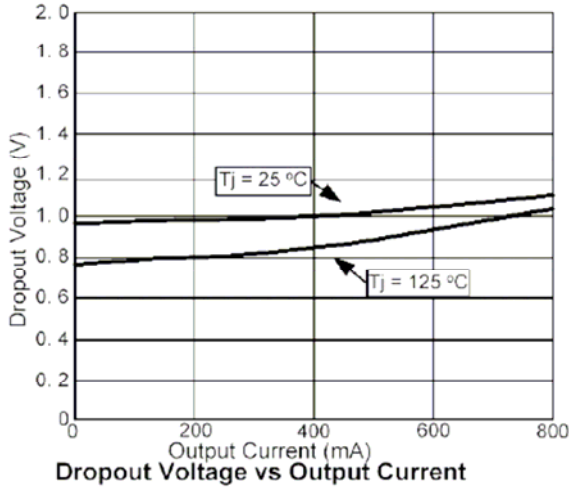

TO-220FP Dimension

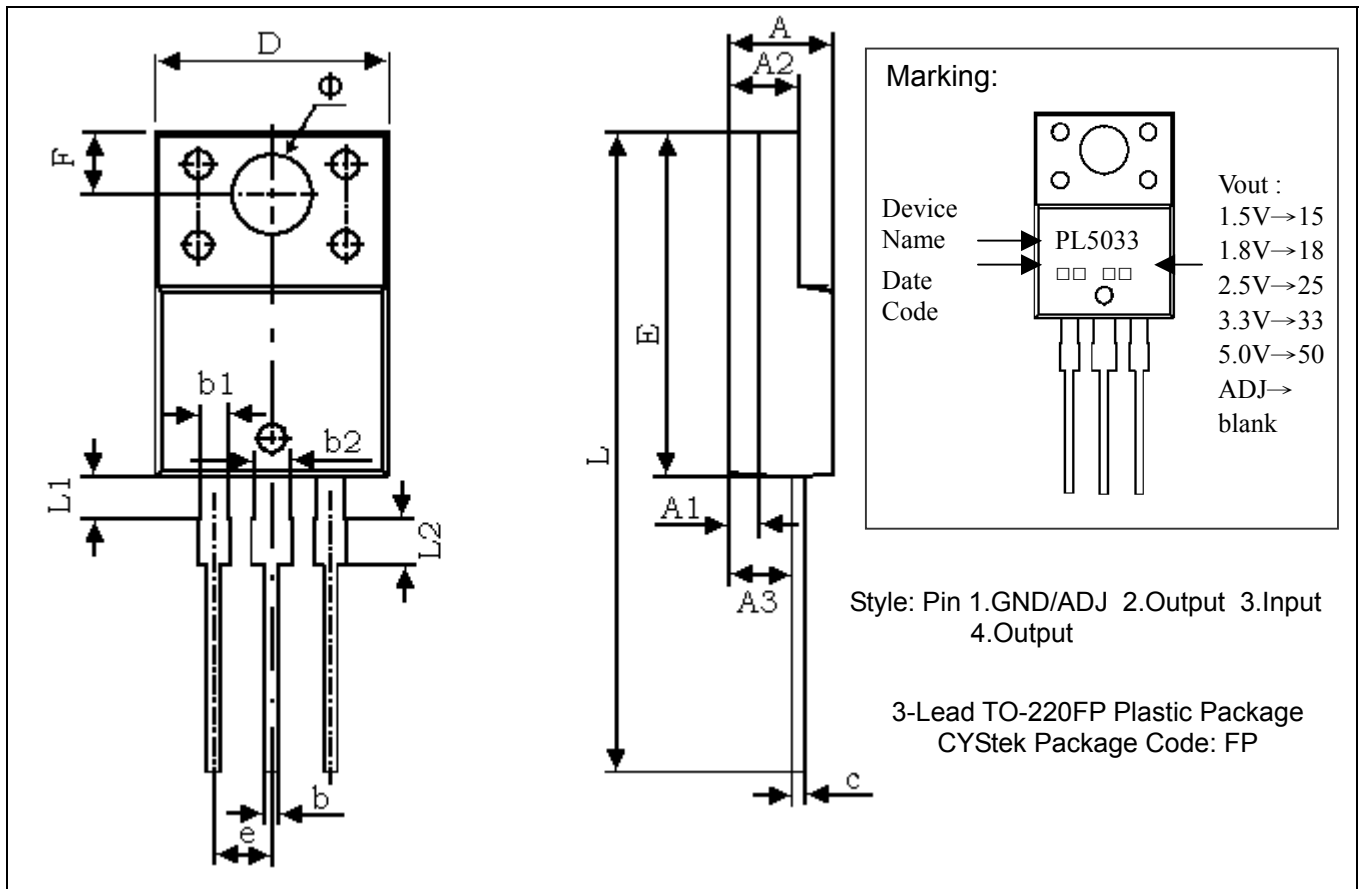

*: Typical

DIM	Inches		Millimeters		DIM	Inches		Millimeters	
	Min.	Max.	Min.	Max.		Min.	Max.	Min.	Max.
A	0.169	0.185	4.300	4.700	D	0.392	0.408	9.960	10.360
A1	0.051 REF		1.300 REF		E	0.583	0.598	14.800	15.200
A2	0.110	0.126	2.800	3.200	e	0.100 TYP		2.540 TYP	
A3	0.098	0.114	2.500	2.900	F	0.106 REF		2.700 REF	
b	0.020	0.030	0.500	0.750	Φ	0.138 REF		3.500 REF	
b1	0.043	0.053	1.100	1.350	L	1.102	1.118	28.000	28.400
b2	0.059	0.069	1.500	1.750	L1	0.067	0.075	1.700	1.900
c	0.020	0.030	0.500	0.750	L2	0.075	0.083	1.900	2.100

- Notes:**
- 1.Controlling dimension: millimeters.
 - 2.Maximum lead thickness includes lead finish thickness, and minimum lead thickness is the minimum thickness of base material.
 - 3.If there is any question with packing specification or packing method, please contact your local CYStek sales office.

Material:

- Mold Compound: Epoxy resin family, flammability solid burning class: UL94V-0

Important Notice:

- All rights are reserved. Reproduction in whole or in part is prohibited without the prior written approval of CYStek.
- CYStek reserves the right to make changes to its products without notice.
- CYStek **semiconductor products are not warranted to be suitable for use in Life-Support Applications, or systems.**
- CYStek assumes no liability for any consequence of customer product design, infringement of patents, or application assistance.