

FEATURES

- Plastic package has Underwriters Laboratory Flammability Classification 94V-0
- Metal silicon junction ,majority carrier conduction
- Guard ring for overvoltage protection
- Low power loss ,high efficiency
- High current capability ,low forward voltage drop
- High surge capability
- High temperature soldering guaranteed:260°C/10 seconds at terminals
- Component in accordance to RoHS 2011/65/EU and WEEE 2012/19/EU

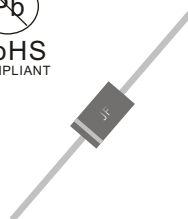

DO-201AD

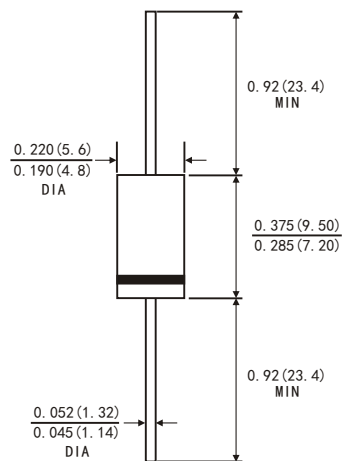

Dimensions in inches and (millimeters)

MECHANICAL DATA

- Case: JEDEC DO-201AD molded plastic body
- Terminals: Plated axial leads, solderable per MIL-STD-750,method 2026
- Polarity: color band denotes cathode end
- Mounting Position: Any
- Weight: 0.041ounce, 1.15 grams

TYPICAL APPLICATIONS

For use in low voltage ,high frequency inverters ,DC/DC converters, free wheeling ,and polarity protection applications

PRIMARY CHARACTERISTICS	
$I_{F(AV)}$	10.0A
V_{RRM}	80V
I_{FSM}	150A
V_F at $I_F=10.0A$	0.58V
T_{JMAX}	150°C

MAXIMUM RATINGS

(Ratings at 25°C ambient temperature unless otherwise specified)

Parameter	Symbol	SR1080L	Unit
Maximum repetitive peak reverse voltage	V_{RRM}	80	V
Maximum average forward rectified current 0.375"(9.5mm) lead length(see fig.1)	$I_{F(AV)}$	10.0	A
Peak forward surge current 8.3ms single half sine-wave superimposed on rated load (JEDEC method at rated TL)	I_{FSM}	150	A
Operating junction temperature range	T_J	-55 to+150	°C
Storage temperature range	T_{stg}	-55 to+150	°C

RATINGS AND CHARACTERISTIC OF SR1080L

ELECTRICAL CHARACTERISTICS (T_A=25°C Unless otherwise noted)

Parameter	Test Conditions		Symbol	TYP.	MAX.	Unit
Instantaneous forward voltage	I _F =10.0A	T _A =25°C	V _F ¹⁾	0.58	0.62	V
		T _A =100°C		0.55	—	
		T _A =125°C		0.54	—	
Reverse current	V _R =80V	T _A =25°C	I _R ²⁾	15	200	μA
		T _A =100°C		2	—	mA
		T _A =125°C		7	—	
Typical junction capacitance	4V, 1MHz		C _J	570		pF

Notes: 1.Pulse test: 300 μs pulse width, 1% duty cycle

2.Pulse test: pulse width ≤ 40ms

THERMAL CHARACTERISTICS (T_A=25°C Unless otherwise noted)

Parameter	Symbol	SR1080L	Unit
Typical thermal resistance ³⁾	R _{θJA}	25.0	°C/W
	R _{θJL}	8.0	

3.Thermal resistance from junction to lead vertical P.C.B. mounted , 0.375"(9.5mm)lead length

AVAILABLE PACK INFORMATION

Product code	Pack	Box Size L*W*H(mm)	Quantity (pcs/box)	Carton Size L*W*H(mm)	Quantity (box/carton)
SR1080L-DO-201AD	B/P	190*80*21	200	433*203*230	50
SR1080L-DO-201AD	T/B	264*74*135	1000	400*267*286	10

RATINGS AND CHARACTERISTIC OF SR1080L

FIG.1-FORWARD CURRENT DERATING CURVE

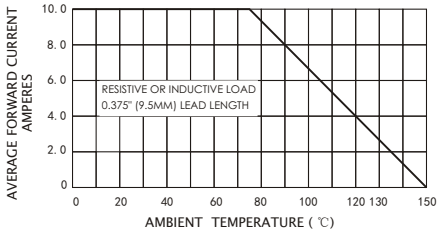

FIG.2-MAXIMUM NON-REPETITIVE PEAK FORWARD SURGE CURRENT

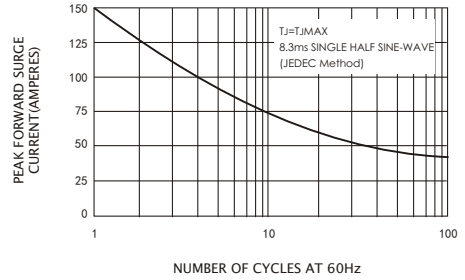

FIG.3-TYPICAL INSTANTANEOUS FORWARD CHARACTERISTICS

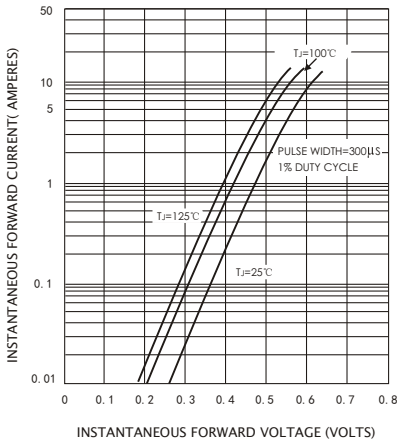

FIG.4-TYPICAL REVERSE CHARACTERISTICS

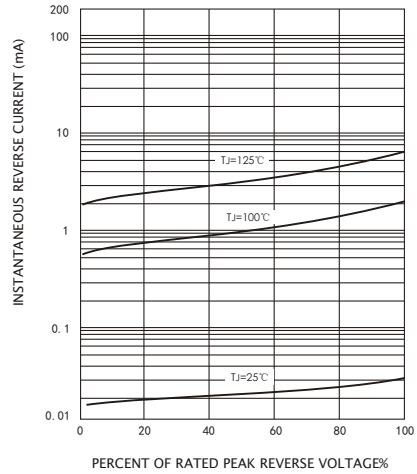

FIG.5-TYPICAL JUNCTION CAPACITANCE

