

GAU205P-15402 Universal Gate Drive Prototype Board

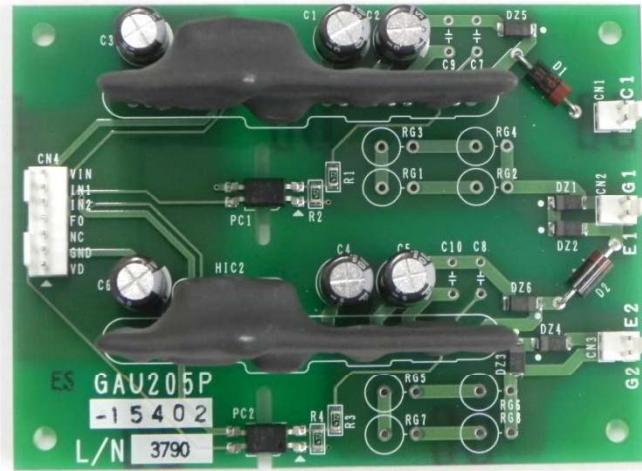

Size : 73.5 x 100 x 40t

Gate Driver(Built in power) : VLA551K-01R

FEATURE

- >Built in the isolated DC-DC converter for gate drive
- >Output peak current is +/-5A(max)
- >Built in short circuit protection
- >Electrical isolation voltage is 4000Vrms (for 1 minute)
- >Two way power supply system for drivers and input signal (VD=15V , VIN=5V)
- >CMOS compatible input interface

TARGETED IGBT MODULES

- VCES = 600V series ~ 600A class
- VCES = 1200V series ~ 450A class
- VCES = 1700V series ~ 450A class

BLOCK DIAGRAM

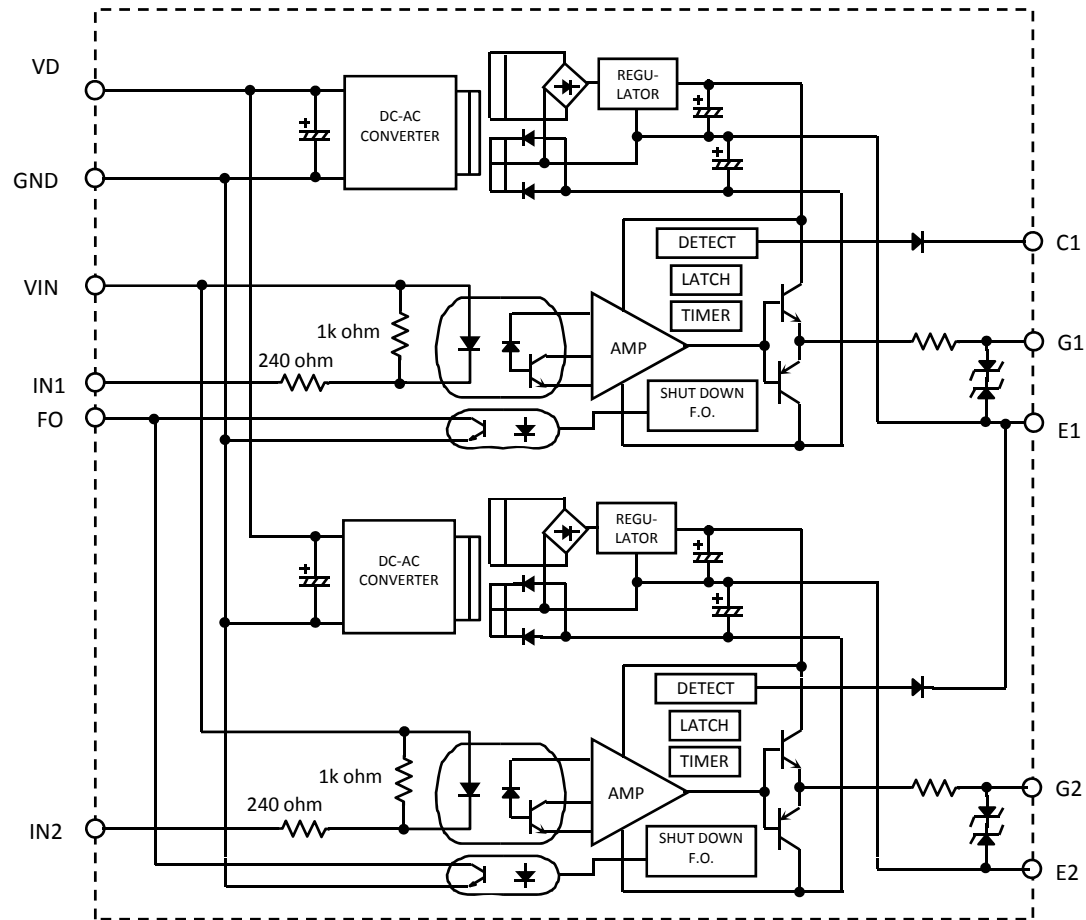

MAXIMUM RATINGS

(unless otherwise noted, Ta=25C)

Symbol	Parameter	Conditions	Ratings	Unit
VD	Supply voltage	DC	-1 ~ 16.5	V
VI	Input signal voltage	Applied between pin 6-7 50% Duty cycle , pulse width 1ms	-1 ~ +7	V
IOHP	Output peak current	Pulse width 2us	-5	A
IOLP			5	A
Viso	Isolation voltage	Sine wave voltage 60Hz, for 1min	4000	Vrms
Topr	Operating temperature	No condensation allowable	-40 ~ 70	deg C
Tstg	Storage temperature	No condensation allowable	-40 ~ 85	deg C
Idrive	Gate drive current	Gate average current (Per one circuit)	100	mA

ELECTRICAL CHARACTERISTICS

(unless otherwise noted, Ta=25C, VD=15V, RG=3Ω)

Symbol	Parameter	Conditions	Limits			Unit
			Min	Typ	Max	
VD	Supply voltage	Recommended range	14.2	15	15.8	V
VIN	Pull-up voltage on input side	Recommended range	4.75	5	5.25	V
IiH	“H” input signal current	Recommended range	10	13	16	mA
f	Switching frequency	Recommended range	-	-	20	kHz
RG	Gate resistance	Recommended range	2	-	-	ohm
VOH	Plus bias voltage	-	14	15.3	16.5	V
VOL	Minus bias voltage	-	-5.5	-	-11	V
tPLH	“L-H” propagation time	IiH = 13mA	0.2	0.4	1	μs
tPHL	“H-L” propagation time	IiH = 13mA	0.2	0.4	1	μs
VSC	SC detect voltage	-	15	-	-	V

INNER CIRCUIT

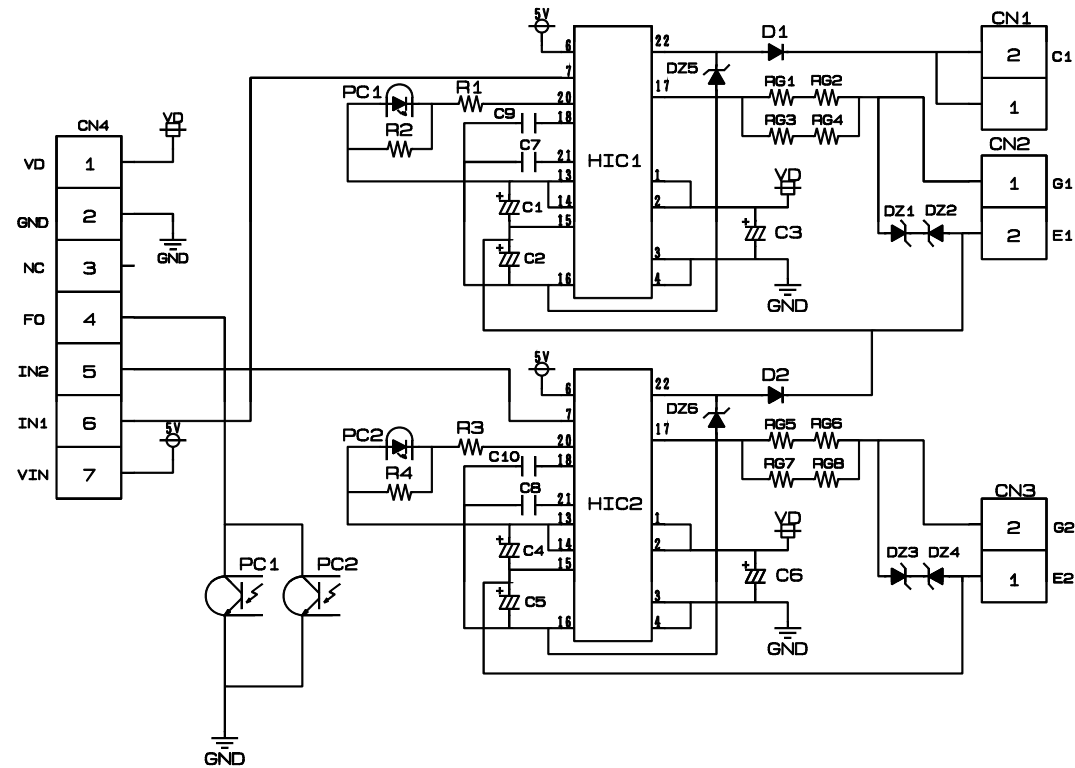

HIC1,2	VLA551K-01R	ISAHAYA
PC1,2	TLP781 compatible	TOSHIBA
D1,2	RP1H	SanKen
DZ1,2,3,4	Vz=18V,500mW	
DZ5,6	Vz=30V,500mW	
C1,2,3,4,5,6	100uF,50V	Low impedance
RG	Gate Resistor	
R1,2,3,4	4.7k ohm, 250mW	
CN1,2,3	5045-02A	Molex
CN4	5045-07A	Molex

*1) Gate Resistor is not installed at the time of shipment.
Please solder the chosen resistor.

*2) C7,8 is not installed at the time of shipment.
Please solder the chosen condenser if needed.
(50V,ceramic)

*3) When you make late speed of reverse bias at the time of short circuit protection operation, please adjust and connect a capacitor between pin 16 and 18.

APPLICATION EXAMPLE

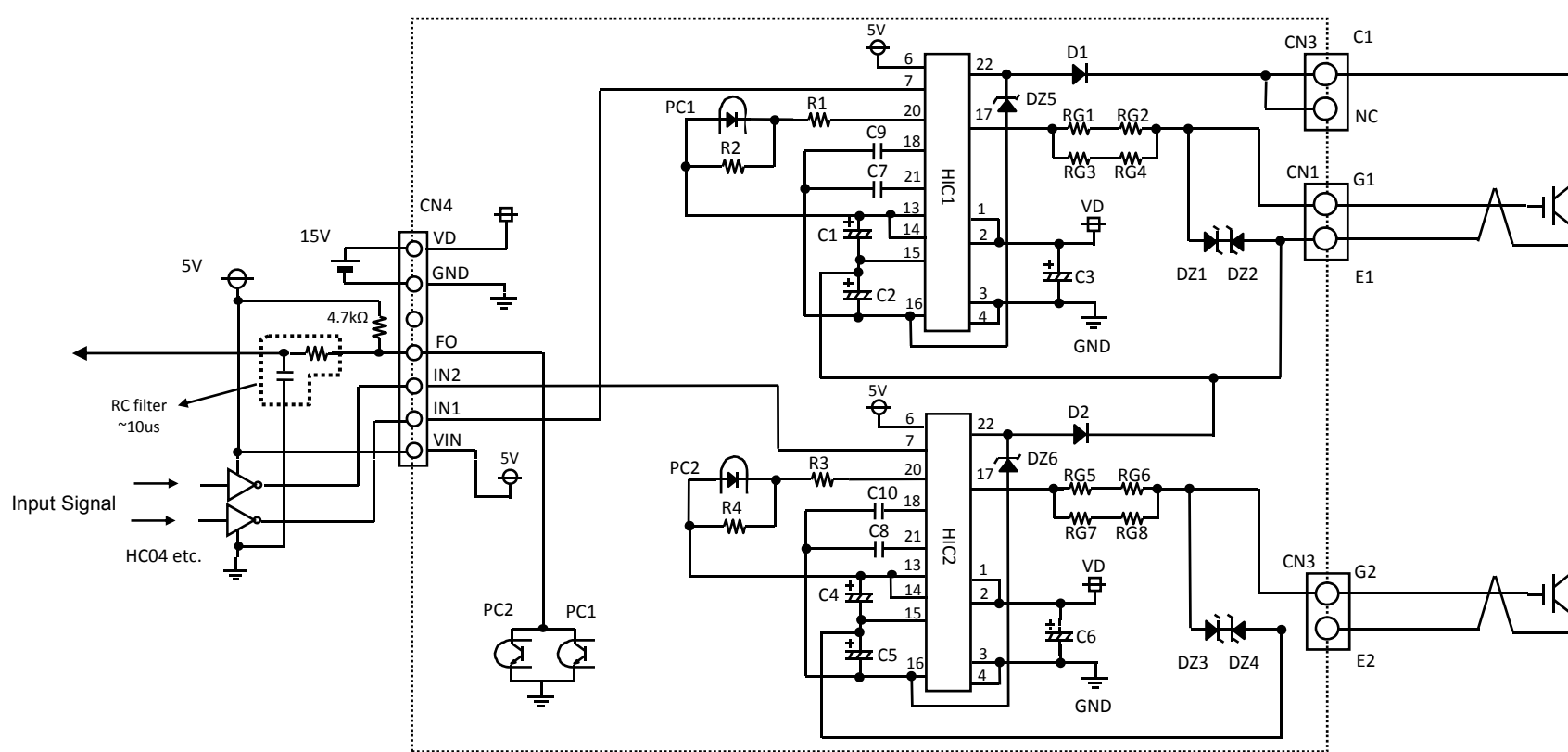

※When you confirm the gate output without connecting IGBT, please invalidate a short-circuit protection.
If connect resistance of 4.7kΩ between the C1(E1) and E1(E2), the short circuit protection becomes invalid.

Part arrangement & Size

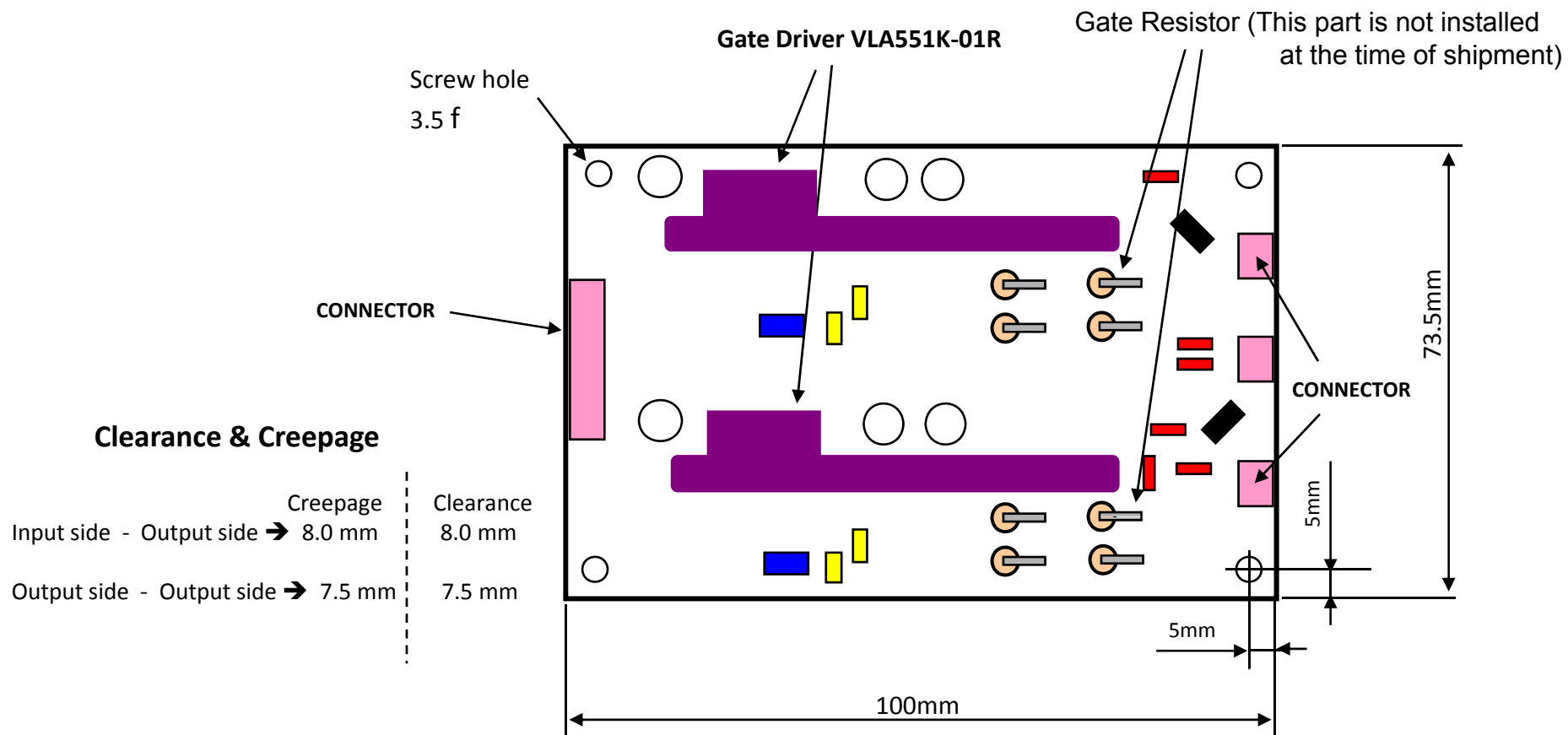

FOR SAFETY USING

Great detail and careful attention are given to the production activity of Hics, such as the development, the quality of production, and in its reliability. However the reliability of Hics depends not only on their own factors but also in their condition of usage. When handling Hics, please note the following cautions.

CAUTIONS	
Packing	The materials used in packing Hics can only withstand normal external conditions. When exposed to outside shocks, rain and certain environmental contaminators, the packing materials will deteriorates. Please take care in handling.
Carrying	<ol style="list-style-type: none">1)Don't stack boxes too high. Avoid placing heavy materials on boxes.2)Boxes must be positioned correctly during transportation to avoid breakage.3)Don't throw or drop boxes.4)Keep boxes dry. Avoid rain or snow.5)Minimal vibration and shock during transportation is desirable.
Storage	When storing Hics, please observe the following notices or possible deterioration of their electrical characteristics, risk of solder ability, and external damage may occur. <ol style="list-style-type: none">1)Devices must be stored where fluctuation of temperature and humidity is minimal, and must not be exposed to direct sunlight. Store at the normal temperature of 5 to 30 degrees Celsius with humidity at 40 to 60%.2)Avoid locations where corrosive gasses are generated or where much dust accumulates.3)Storage cases must be static proof.4)Avoid putting weight on boxes.
Extended storage	When extended storage is necessary, Hics must be kept non-processed. When using Hics which have been stored for more than one year or under severe conditions, be sure to check that the exterior is free from flaw and other damages.
Maximum ratings	To prevent any electrical damages, use Hics within the maximum ratings. The temperature, current, voltage, etc. must not exceed these conditions.
Polarity	To protect Hics from destruction and deterioration due to wrong insertion, make sure of polarity in inserting leads into the board holes, conforming to the external view for the terminal arrangement.

Keep safety first in your circuit designs!

·ISAHAYA Electronics Corporation puts the maximum effort into making semiconductor products better and more reliable, but there is always the possibility that trouble may occur with them. Trouble with semiconductors may lead to personal injury, fire or property damage. Remember to give due consideration to safety when making your circuit designs, with appropriate measures such as (1) placement of substitutive, auxiliary, (2) use of non-flammable material or (3) prevention against any malfunction or mishap.

Notes regarding these materials

·These materials are intended as a reference to our customers in the selection of the ISAHAYA products best suited to the customer's application; they don't convey any license under any intellectual property rights, or any other rights, belonging to ISAHAYA or third party.

·ISAHAYA Electronics Corporation assumes no responsibility for any damage, or infringement of any third party's rights, originating in the use of any product data, diagrams, charts or circuit application examples contained in these materials.

·All information contained in these materials, including product data, diagrams and charts, represent information on products at the time of publication of these materials, and are subject to change by ISAHAYA Electronics Corporation without notice due to product improvements or other reasons. It is therefore recommended that customers contact ISAHAYA Electronics Corporation or an authorized ISAHAYA products distributor for the latest product information before purchasing product listed herein.

·ISAHAYA Electronics Corporation products are not designed or manufactured for use in a device or system that is used under circumstances in which human life is potentially at stake. Please contact ISAHAYA electronics corporation or an authorized ISAHAYA products distributor when considering the use of a product contained herein for any specific purposes, such as apparatus or systems for transportation, vehicular, medical, aerospace, nuclear, or undersea repeater use.

·The prior written approval of ISAHAYA Electronics Corporation is necessary to reprint or reproduce in whole or in part these materials.

·If these products or technologies are subject to the Japanese export control restrictions, they must be exported under a license from the Japanese government and cannot be imported into a country other than the approved destination. Any diversion or re-export contrary to the export control laws and regulations of Japan and/or the country of destination is prohibited.

·Please contact ISAHAYA Electronics Corporation or authorized ISAHAYA products distributor for further details on these materials or the products contained therein.