ML7012-06

2400 bps Single Chip Full Duplex Data Modem with Protocol

GENERAL DESCRIPTION

The ML7012-06 is a single chip modem LSI device that enables data communication conforming to ITU-T recommendations V.22bis, V.22 and V.21. This LSI is also equipped with the error correction protocol function complying with MNP-class 4. (The MNP-class 4 is available in V.22bis or V.22 mode.)

The ML7012-06 consists of high speed DSP, analog front end, and digital logic circuit. In addition, this device provides local analog loop testing, synchronous/asynchronous converter, dialing, and auto answering functions.

The ML7012-06 has an external serial interface. When integrated into the system, it is controlled from a control CPU through a serial interface (e.g. UART). By connecting a level converter, the ML7012-06 can easily implement a modem that can be controlled through the RS-232C-interface.

FEATURES

- Conforming to ITU-T Recommendations V.22 bis, V.22, and V.21: Asynchronous
- Error correction function compliant to MNP-class 4
- Serial interface: V.24 interface
- AT commands (excluding automatic command speed detection)
- Terminal data speed between DTE and DCE: 9600 bps, 2400 bps, 1200 bps, 300 bps
- Character format: 10 bit/character
- DTMF generating function
- Pulse-dial control signal outputs
- Call progress tone detection
- Auto answering function
- Built-in electronic hybrid circuit (a line transformer can be directly coupled)
- Single +3 V power supply
- Power consumption: Typ.= 35mA (VDD=3.3V)
- Package: 64-pin plastic QFP (QFP64-P-1414-0.80-BK) (ML7012-06GA)

* MNP (Microcom Networking Protocol) is a registered trademark of Hewlett-Packard Company (previously Microcom Corp.)

BLOCK DIAGRAM

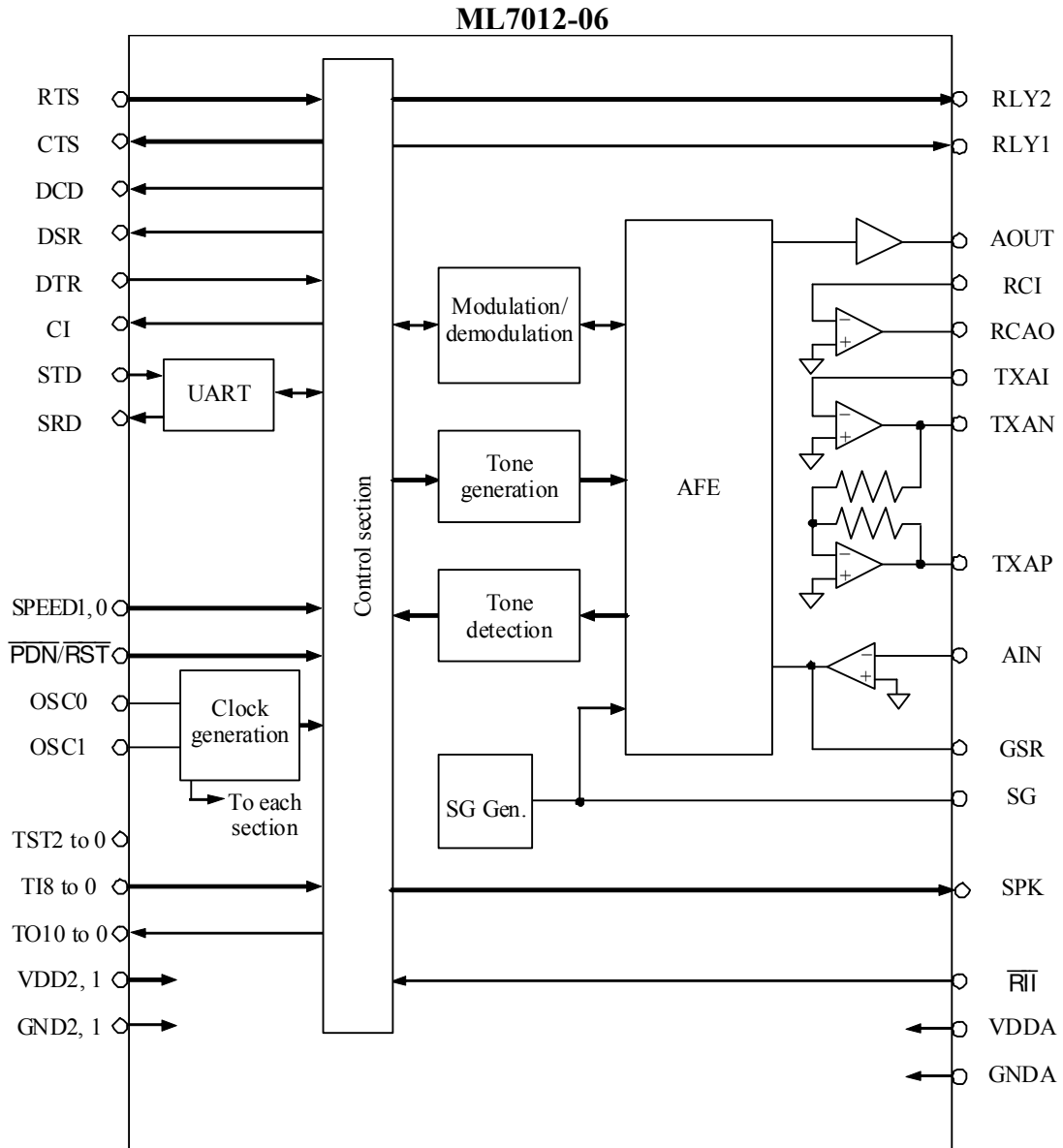

PIN CONFIGURATION (TOP VIEW)

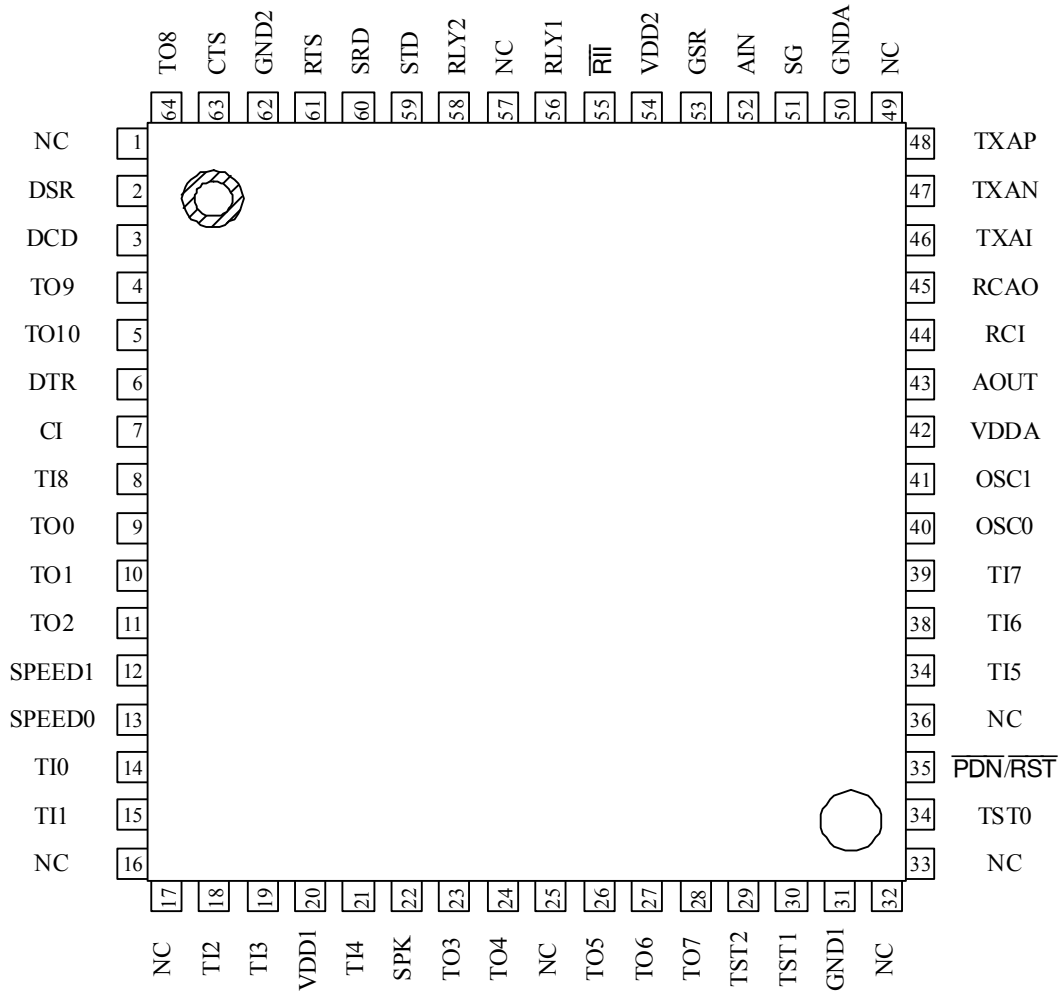

64-Pin Plastic QFP

Note: Pins marked (NC) are no-connection pins that are left open.

PIN DESCRIPTIONS

System & Clock

| Symbol | Type | Description |
|-----------------------------|------|--|
| OSC0 | I | Pins to connect crystal, resistors and capacitors for the master clock oscillation. When supplying the master clock from an external source, use OSC0 and leave OSC1 open. |
| OSC1 | O | Master clock frequency = 11.0592 MHz. When $\overline{\text{PDN/RST}} = "0"$, OSC1 outputs "1". Refer to the "Connection of Crystal Oscillator" in page 20 for further details. |
| $\overline{\text{PDN/RST}}$ | I | Power-down and reset control input pin. When $\overline{\text{PDN/RST}} = "0"$, this device is in the power-down state and internal circuits are reset. "0": Power-down state, "1": Normal operation After power-on, set this pin to "0" for 1 μs or more to reset internal circuits. 230 ms (min.) is required to resume normal operation after reset release. If this pin remains at "0" after power-on, the internal circuits become undefined and the power-down current may increase. To avoid this, input "1" to this pin and start oscillation or input the master clock to operate the internal circuits, and then set it to "0" |

V.24 Serial Interface

| Symbol | Type | Description |
|--------|------|--|
| STD | I | Transmission data input pin "0": Space, "1": Mark |
| SRD | O | Receive data output pin "0": Space, "1": Mark When $\overline{\text{PDN/RST}} = "0"$, SRD outputs "1". |
| RTS | I | RTS (Request to Send) signal input pin "0": On, "1": Off |
| CTS | O | CTS (Clear to Send) signal output pin "0": On, "1": Off When $\overline{\text{PDN/RST}} = "0"$, CTS outputs "1". |
| DCD | O | DCD (Data Carrier Detect) signal output pin "0": On, "1": Off When $\overline{\text{PDN/RST}} = "0"$, DCD outputs "1". |
| DSR | O | DSR (Data Set Ready) signal output pin "0": On, "1": Off When $\overline{\text{PDN/RST}} = "0"$, DSR outputs "1". |
| DTR | I | DTR (Data Terminal Ready) signal input pin "0": On, "1": Off |
| CI | O | CI (Calling Indicator) signal output pin (*2) "0": On, "1": Off When $\overline{\text{PDN/RST}} = "0"$, CI outputs "1". |

Analog Interface

| Symbol | Type | Description |
|--------|------|---|
| AOUT | O | Transmit analog output pin When $\overline{\text{PDN/RST}} = "0"$, AOUT is in a high impedance state. |
| RCI | I | Operational amplifier input pin constituting transmit RC active |
| RCAO | O | Operational amplifier output pin constituting transmit RC active When $\overline{\text{PDN/RST}} = "0"$, RCAO is in a high impedance state. |
| TXAI | I | Input pin of the first line transformer drive amplifier |
| TXAN | O | Output pin of the first line transformer drive amplifier When $\overline{\text{PDN/RST}} = "0"$, TXAN is in a high impedance state. |
| TXAP | O | Output pin of the second line transformer drive amplifier Outputs the inverted signal of TXAN When $\overline{\text{PDN/RST}} = "0"$, TXAP is in a high impedance state. |
| AIN | I | Input pin of the receive input amplifier |
| GSR | O | Output pin of the receive input amplifier When $\overline{\text{PDN/RST}} = "0"$, GSR is in a high impedance state. |
| SG | O | Output of internal signal ground circuited Connect to GNDA through 1 μ F capacitor. When $\overline{\text{PDN/RST}} = "0"$, SG is in a high impedance state. |

PSTN Line Control Interface

| Symbol | Type | Description |
|-------------------------|------|---|
| RLY1 | O | Output pin of signals to control off-hook and dial pulses. (*1) "0" : On-hook or break state of dial pulse, "1" : Off-hook or make state of dial pulse When $\overline{\text{PDN/RST}} = "0"$, this pin outputs "0". |
| RLY2 | O | Output pin of signals to control a connection to a parallelly connected telephone. (*1) "0" : phone line is connected to the parallelly connected phone "1" : phone line is connected to the modem (the parallelly connected phone is disconnected from the phone line) When $\overline{\text{PDN/RST}} = "0"$, this pin outputs "0". |
| $\overline{\text{RII}}$ | I | Call-in state input pin. (*2) Input "0" when call-in is detected. Input "1" when call-in is not detected. When a ring detect circuit is not used, input "1". |
| SPK | O | Output for speaker control signal "0" : speaker On, "1" : speaker Off When $\overline{\text{PDN/RST}} = "0"$, this pin outputs "1". |

Other Interface

| Symbol | I/O | Description | | |
|---------|-----|---|---------|----------|
| SPEED 1 | I | Data Transmission Speed between DTE and DCE | | |
| | | SPEED 1 | SPEED 0 | Speed |
| SPEED 0 | I | 0 | 0 | 300 bps |
| | | 0 | 1 | 1200 bps |
| | | 1 | 0 | 2400 bps |
| | | 1 | 1 | 9600 bps |

Test Interface

| Symbol | Type | Description | | | | | | | | | | | | | | | | | | | | | | | | | |
|--|------|--|-----|--|-----|--|----------------------------|---|---|---|---|--|---|---|---|---|--|---|---|---|---|---|---|---|---|---|--|
| TST2 to 0 | I | Test pins for the LSI manufacturer. Input "0". | | | | | | | | | | | | | | | | | | | | | | | | | |
| TI8 to 0 | I | In normal operation state, input "0" to all of the TI8 to 0. The input combination in the table below realizes test modes. (Input "0" to TI8, TI6, TI5, TI3, and TI2 in the case, too.) | | | | | | | | | | | | | | | | | | | | | | | | | |
| | | <table border="1"> <thead> <tr> <th>TI7</th> <th>TI4</th> <th>TI1</th> <th>TI0</th> <th>Test function, description</th> </tr> </thead> <tbody> <tr> <td>1</td> <td>0</td> <td>0</td> <td>0</td> <td>Continuous output of DTMF tones (Code A)</td> </tr> <tr> <td>1</td> <td>1</td> <td>0</td> <td>0</td> <td>Continuous output of originate scramble "1" of V.22bis (2400bps)</td> </tr> <tr> <td>1</td> <td>1</td> <td>0</td> <td>1</td> <td>Continuous output of answer scramble "1" of V.22bis (2400bps)</td> </tr> <tr> <td>1</td> <td>0</td> <td>1</td> <td>0</td> <td>AC loop test It takes approx. 2 seconds to get into the AC loop test mode. RTS signal is required to be ON.</td> </tr> </tbody> </table> | TI7 | TI4 | TI1 | TI0 | Test function, description | 1 | 0 | 0 | 0 | Continuous output of DTMF tones (Code A) | 1 | 1 | 0 | 0 | Continuous output of originate scramble "1" of V.22bis (2400bps) | 1 | 1 | 0 | 1 | Continuous output of answer scramble "1" of V.22bis (2400bps) | 1 | 0 | 1 | 0 | AC loop test It takes approx. 2 seconds to get into the AC loop test mode. RTS signal is required to be ON. |
| | | TI7 | TI4 | TI1 | TI0 | Test function, description | | | | | | | | | | | | | | | | | | | | | |
| | | 1 | 0 | 0 | 0 | Continuous output of DTMF tones (Code A) | | | | | | | | | | | | | | | | | | | | | |
| | | 1 | 1 | 0 | 0 | Continuous output of originate scramble "1" of V.22bis (2400bps) | | | | | | | | | | | | | | | | | | | | | |
| | | 1 | 1 | 0 | 1 | Continuous output of answer scramble "1" of V.22bis (2400bps) | | | | | | | | | | | | | | | | | | | | | |
| 1 | 0 | 1 | 0 | AC loop test It takes approx. 2 seconds to get into the AC loop test mode. RTS signal is required to be ON. | | | | | | | | | | | | | | | | | | | | | | | |
| When entering a test mode, execute reset using $\overline{\text{PDN/RST}}$ pin after TI8 to 0 are set as intended. | | | | | | | | | | | | | | | | | | | | | | | | | | | |
| When escaping from the test mode, execute reset using $\overline{\text{PDN/RST}}$ pin after TI8 to 0 are set to "0". | | | | | | | | | | | | | | | | | | | | | | | | | | | |
| TO10 to 0 | O | Leave open | | | | | | | | | | | | | | | | | | | | | | | | | |

Power Supply

| Symbol | Type | Description |
|-----------|------|--|
| VDDA | I | Analog VDD pin. Supply 2.7 - 3.6V. Connect a ceramic capacitor with good high frequency characteristics (0.1 to 1 μ F) and an electrolytic capacitor (10 to 20 μ F) in parallel between this terminal and GNDA. |
| GNDA | I | Analog GND pin |
| VDD2 to 1 | I | Digital VDD pins. Supply 2.7 - 3.6V. Supply the same voltage to the VDDA. Connect a ceramic capacitor with good high frequency characteristics (0.1 to 1 μ F) and an electrolytic capacitor (10 to 20 μ F) in parallel between this terminal and GND2/GND1. |
| GND2 to 1 | I | Digital GND pins. |

(*1)

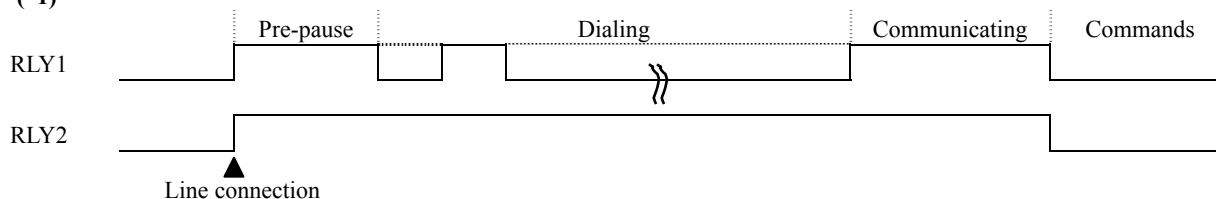

(*2)

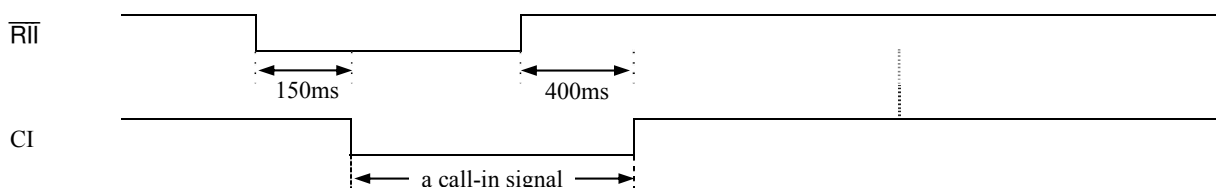

ABSOLUTE MAXIMUM RATINGS

| Parameter | Symbol | Rating | Unit |
|------------------------------|-----------|----------------------|------|
| Power Supply Voltage | V_{DD} | -0.3 to +5.0 | V |
| Analog Input Voltage | V_{AIN} | -0.3 to $V_{DD}+0.3$ | V |
| Digital Input Voltage | V_{DIN} | -0.3 to $V_{DD}+0.3$ | V |
| Power dissipation | P_D | to 500 | mW |
| Output short-circuit current | I_{OUT} | to 90 | mA |
| Storage Temperature | T_{STG} | -55 to +150 | °C |

RECOMMENDED OPERATING CONDITIONS

| Parameter | Symbol | Condition | Min. | Typ. | Max. | Unit | |
|----------------------------------|---------------------------------|--|---------------------------------------|---------|----------------------|------|-----|
| Power Supply Voltage | V_{DD} | — | 2.7 | — | 3.6 | V | |
| Operating Temperature | T_{OP} | — | -20 | +25 | +70 | °C | |
| High Level Input Voltage | V_{IH} | All digital input pins excluding OSC0 | $0.7 \times V_{DD}$ | — | V_{DD} | V | |
| Low Level Input Voltage | V_{IL} | | 0 | — | $0.16 \times V_{DD}$ | V | |
| Digital Input Rise time | tir | All digital input pins | — | — | 20 | ns | |
| Digital Input Fall Time | tif | | — | — | 20 | ns | |
| Input Clock Frequency Deviation | FMCK | 11.0592 MHz | -100 | — | +100 | ppm | |
| Master CLK Duty Ratio | DMCK | Input to OSC0 | 40 | 50 | 60 | % | |
| Digital Output Load | C_{DL} | Digital output pins | — | — | 50 | pF | |
| R1to R3 Resistance Ratio (R3/R1) | Rrat1 | — | — | 1 | 1.05 | — | |
| R4to R5 Resistance Ratio (R5/R4) | Rrat2 | $V_{DD} \geq 3V$ | — | — | 2 | — | |
| | Rrat3 | $V_{DD} \geq 2.7V$ | — | — | 1.6 | — | |
| SG Bypass Capacitor | C_{SG} | SG pin | 1 | — | — | μF | |
| Oscillator Feedback Resistance | R_{OSC} | Between OSC0 and OSC1 | 800 | 1000 | 1200 | KΩ | |
| OSC0 and OSC1 Load Capacitance | C_{O1}, C_{O2} | OSC0 and OSC1 pins | — | 15 | — | pF | |
| Crystal | Oscillation Frequency | — | — | 11.0592 | — | MHz | |
| | Frequency Deviation | — | Including temperature characteristics | -80 | — | +80 | ppm |
| | Equivalent Series Resistance *1 | — | — | — | — | 90 | Ω |
| | Load Capacitance *1 | — | — | — | 12 | — | pF |

*1: If a matching by a crystal manufacturer is sufficiently verified, the values of equivalent series resistance and load capacitance may be changeable so long as the frequency deviation is within the range specified above.

ELECTRICAL CHARACTERISTICS

DC Characteristics

($V_{DD} = 2.7V$ to $3.6V$, $T_a = -20^{\circ}C$ to $+70^{\circ}C$)

| Parameter | Symbol | Condition | Min. | Typ. | Max. | Unit |
|-----------------------------------|-----------|------------------------|---------------------|----------------------|------|---------|
| Power Supply Current | I_{DD} | — | — | 35 | 65 | mA |
| | I_{DDs} | During power-down (*1) | — | 1 | 1000 | μA |
| Input Leakage Current | I_{IH} | $V_I = V_{DD}$ | — | 0 | 20 | μA |
| | I_{IL} | $V_I = 0V$ | — | 0 | 20 | μA |
| High Level Digital Output Voltage | V_{OH1} | $I_{OH} = -5mA$ (*2) | $0.8 \times V_{DD}$ | $0.96 \times V_{DD}$ | — | V |
| | V_{OH2} | $I_{OH} = -0.4mA$ (*3) | $0.8 \times V_{DD}$ | $0.99 \times V_{DD}$ | — | V |
| Low Level Digital Output Voltage | V_{OL} | $I_{OL} = 3.2mA$ | — | 0.1 | 0.4 | V |
| Input Capacitance | C_{IN} | — | — | 5 | — | pF |

*1 When the power down mode is activated while the device is in operating mode.

*2 Applicable to RLY1 and RLY2 pins. The output current from these pins must be limited less than 8 mA by the external circuitry.

*3 Applicable to all digital output pins except RLY1 and RLY2.

Analog Interface

(V_{DD} = 2.7V to 3.6 V, Ta = -20°C to +70°C)

| Parameter | Symbol | Condition | Min. | Typ. | Max. | Unit | |
|---|------------------|---------------------------|-------------------------------------|-------|-------|-----------|-----|
| Input Resistance | R _{IN} | RCI, TXAI, AIN | — | 10 | — | MΩ | |
| Output Load Resistance | R _{L1} | AOUT, RCAO, GSR | 20 | — | — | kΩ | |
| | R _{L2} | Between TXAN and TXAP | 1080 | — | — | Ω | |
| Output Load Capacitance | C _L | Analog output | — | — | 100 | pF | |
| SG Output Voltage | V _{SG} | SG | 1.3 | 1.4 | 1.65 | V | |
| SG Output Impedance | R _{SG} | SG | — | 30 | — | kΩ | |
| Carrier Output Level | VAOM | AOUT, S34 = 0 dB | -19.5 | -18.0 | -16.0 | dBm *1 | |
| DTMF Low Group Output Level | VDTL | AOUT, S35 = 0 dB | -17.0 | -15.5 | -13.5 | dBm | |
| DTMF High Group Output Level | VDTH | AOUT, S35 = 0 dB | -16.0 | -14.5 | -12.5 | dBm | |
| DTMF Output Frequency Precision | TSDF | Against nominal frequency | -1.5 | — | +1.5 | % | |
| Answer Tone Output Level | VAOAT | AOUT, S34 = 0 dB | -20.0 | -18.0 | -15.5 | dBm | |
| Answer Tone Output Frequency Precision | TSAF | Against 2100 Hz | -10 | — | +10 | Hz | |
| Undesired Sending Level | VS1 | TXAN, TXAP | 4 to 8 kHz | — | — | -20 | dBm |
| | VS2 | | 8 to 12 kHz | — | — | -40 | dBm |
| | VS3 | | 12 kHz or more (each 4 kHz band) | — | — | -60 | dBm |
| Carrier Receive Input Level | VGSR | GSR level | -46 | — | -15 | dBm | |
| Carrier Detection Level | VON | GSR level *2 | OFF→ ON | -46 | — | — | dBm |
| | VOFF | | ON→ OFF | — | — | -54 | dBm |
| Carrier Detection Delay Time | t _{CDD} | — | OFF→ ON | — | 25 | ms | |
| Carrier Detection Hold Time | T _{CDH} | — | ON→ OFF | — | 15 | ms | |
| Answer Tone Detection / Non-detection Level | ATDL | GSR level | — | -50 | — | dBm | |
| Call Progress Tone Detection / Non-detection Level | CPDL | GSR level | — | -50 | — | dBm | |

*1 The unit of the signal level (dBm) is 0 dBm = 0.775 Vrms at 600 Ω

*2 The values of the carrier detection level are those for QAM, PSK and FSK modulation signals.

COMMAND DESCRIPTIONS

AT Commands

Command format :

AT commands begin with <AT> or <at>. Character strings to a carriage return code are interpreted as commands to be executed successively. A result code is returned to DTE after the completion of interpretations.

AT | Command, Command, Command, | CR | LF

However, the commands of A, D, Dc, On, Zn, Ax, &Tn and &Zn must be set at the end of the sequence of commands. Commands following above commands in the same command line are ignored.

The maximum command character string is 40 characters (space <20h> is ignored).

Input characters can be deleted only by a backspace function in default (The code assignment can be altered).

<CR> is a Carriage Return code in default (The code assignment can be altered).

<LF> is a Line Feed code (Not mandatory; The code assignment can be altered).

Both capital and small letters can be recognized with the exception of At and aT. The communication with the terminal when inputting commands is handled in asynchronous mode, and the character format is checked automatically as soon as <AT> or <at> is input.

Normal operation of the device cannot be guaranteed, when character strings or parameters not listed below are input.

Terminal data speed and character format :

The communication mode to DTE with the V.24 interface is as follows:

Terminal data speed : 9600/2400/1200/300 bps

Character format : Listed below

| Start bit | Data bit | Parity | Stop bit | Character length |
|-----------|----------|-------------|----------|------------------|
| 1 | 7 | None | 2 | 10 |
| 1 | 7 | Odd number | 1 | 10 |
| 1 | 7 | Even number | 1 | 10 |
| 1 | 8 | None | 1 | 10 |

AT command list :

If a parameter (n) is not specified in the command line, a default value n=0 is assumed.

| CMD | Style | Function | Initial Value | Note |
|---------------|-------|--|---------------|--|
| +++AT <CR> | — | Switches from the data mode to the on-line command mode. It becomes effective when it is inputted as follows. +++AT<CR> Switching to the on-line command mode is performed after the input of <CR>. | — | AT and <CR> don't go before the command. |
| A | ATA | Starts line connection in answer mode | — | |
| | ATD | Starts line connection in originate mode | — | |
| D | ATDc | Connects lines in originate mode after dialing. c: Dial control character Pulse: 0, 1, 2, 3, 4, 5, 6, 7, 8, 9 Tone: 0, 1, 2, 3, 4, 5, 6, 7, 8, 9, A, B, C, D, *, # @ Silence Detection Dialing is executed when continuous silence of 5 sec is detected within the period specified in S7 register. Sends back 'BUSY' when busy tone is detected and sends back 'NO ANSWER' when no silence is detected after ring back tone. ! Flash On-hook for 0.5sec, and off-hook again. , Comma Dialing is put on hold for the period specified in the S8 register for pause settings. ; Moves to command mode without disconnecting lines after dialing is completed. P: Dials the numbers in pulse mode thereafter. T: Dials the numbers in tone mode thereafter. W: Detects a dial tone. Continues the dial string process when a dial tone is detected during the period specified in S7 register regardless of ATXn command settings. When no dial tone is detected, 'NO DIALTONE' is returned. | — | |
| E | ATEn | Select the command echo back option. n=0: The command input characters are not echoed-back. n=1: The command input characters are echoed-back. | 1 | |
| H | ATHn | Controls the line connection. n=0: on-hook n=1: off-hook | — | |
| I | ATI0 | Returns the modem manufacturer's code. The execution of ATI0<CR> will results in return of a result code, "24A", back to the DTE. | — | |
| M | ATMn | Selects the monitor speaker operation. n=0: Always OFF n=1: ON from dialing to line connection n=2: Always ON n=3: ON when connected with a remote modem | 1 | |
| O | ATO | Returns from the on-line command mode to the data mode. | — | |
| P | ATP | Set to pulse dialing mode | — | |

| CMD | Style | Function | Initial Value | Note | | | | | | | | | | | | | | | | | | | | | | | | | | | | | | | | | | | | | | | | | | | | | | | |
|-----|--------|--|---------------|------|--------------------------|--------------|----------|-------------|--------------------------|--------------|-------------|---|---|---|---|---|---|---|---|---|---|-------------------------|---------|---|---|---|---|---|--------------------------|--------------|---|---|---|---|---|--------------------------|--------------|---|---|---|---|---|---------------------|--------------|---|---|---|---|---|---------------------|------|
| Q | ATQn | Selects the result code transmission. n=0: Result code is transmitted. n=1: Result code is not transmitted. | 0 | | | | | | | | | | | | | | | | | | | | | | | | | | | | | | | | | | | | | | | | | | | | | | | | |
| S | ATSr | Sets the pointer value for S register to "r". | — | | | | | | | | | | | | | | | | | | | | | | | | | | | | | | | | | | | | | | | | | | | | | | | | |
| | ATSr? | Echoes back the contents of S register specified by "r". | — | | | | | | | | | | | | | | | | | | | | | | | | | | | | | | | | | | | | | | | | | | | | | | | | |
| | ATSr=d | Sets the content of S register specified by "r" to "d". | — | | | | | | | | | | | | | | | | | | | | | | | | | | | | | | | | | | | | | | | | | | | | | | | | |
| T | ATT | Sets dialing mode to DTMF. | — | | | | | | | | | | | | | | | | | | | | | | | | | | | | | | | | | | | | | | | | | | | | | | | | |
| V | ATVn | Selects the type of result code. n=0: Number n=1: Characters | 1 | | | | | | | | | | | | | | | | | | | | | | | | | | | | | | | | | | | | | | | | | | | | | | | | |
| X | ATXn | Selects the extended result code and call progress tone detection. | 4 | | | | | | | | | | | | | | | | | | | | | | | | | | | | | | | | | | | | | | | | | | | | | | | | |
| | | <table border="1"> <thead> <tr> <th colspan="5">n</th> <th rowspan="2">Function</th> <th rowspan="2">Result Code</th> </tr> <tr> <th>0</th> <th>1</th> <th>2</th> <th>3</th> <th>4</th> </tr> </thead> <tbody> <tr> <td>o</td> <td>o</td> <td>o</td> <td>o</td> <td>o</td> <td>Line connection 300 bps</td> <td>CONNECT</td> </tr> <tr> <td>—</td> <td>o</td> <td>o</td> <td>o</td> <td>o</td> <td>Line connection 1200 bps</td> <td>CONNECT 1200</td> </tr> <tr> <td>—</td> <td>o</td> <td>o</td> <td>o</td> <td>o</td> <td>Line connection 2400 bps</td> <td>CONNECT 2400</td> </tr> <tr> <td>—</td> <td>—</td> <td>o</td> <td>—</td> <td>o</td> <td>Dial tone detection</td> <td>NO DIAL TONE</td> </tr> <tr> <td>—</td> <td>—</td> <td>—</td> <td>o</td> <td>o</td> <td>Busy tone detection</td> <td>BUSY</td> </tr> </tbody> </table> | | | n | | | | | Function | Result Code | 0 | 1 | 2 | 3 | 4 | o | o | o | o | o | Line connection 300 bps | CONNECT | — | o | o | o | o | Line connection 1200 bps | CONNECT 1200 | — | o | o | o | o | Line connection 2400 bps | CONNECT 2400 | — | — | o | — | o | Dial tone detection | NO DIAL TONE | — | — | — | o | o | Busy tone detection | BUSY |
| | | n | | | | | Function | Result Code | | | | | | | | | | | | | | | | | | | | | | | | | | | | | | | | | | | | | | | | | | | |
| | | 0 | | | 1 | 2 | | | 3 | 4 | | | | | | | | | | | | | | | | | | | | | | | | | | | | | | | | | | | | | | | | | |
| | | o | | | o | o | o | o | Line connection 300 bps | CONNECT | | | | | | | | | | | | | | | | | | | | | | | | | | | | | | | | | | | | | | | | | |
| | | — | | | o | o | o | o | Line connection 1200 bps | CONNECT 1200 | | | | | | | | | | | | | | | | | | | | | | | | | | | | | | | | | | | | | | | | | |
| — | o | o | o | o | Line connection 2400 bps | CONNECT 2400 | | | | | | | | | | | | | | | | | | | | | | | | | | | | | | | | | | | | | | | | | | | | | |
| — | — | o | — | o | Dial tone detection | NO DIAL TONE | | | | | | | | | | | | | | | | | | | | | | | | | | | | | | | | | | | | | | | | | | | | | |
| — | — | — | o | o | Busy tone detection | BUSY | | | | | | | | | | | | | | | | | | | | | | | | | | | | | | | | | | | | | | | | | | | | | |
| Z | ATZ | Reset in the same way the PDN/RST pin is set to "0". | — | | | | | | | | | | | | | | | | | | | | | | | | | | | | | | | | | | | | | | | | | | | | | | | | |
| &C | AT&Cn | Controls data carrier detection signals (DCD). n=0: Always sets DCD to ON. n=1: Controls DCD by detecting reception carriers. | 0 | | | | | | | | | | | | | | | | | | | | | | | | | | | | | | | | | | | | | | | | | | | | | | | | |
| &D | AT&Dn | Controls the modem dependent upon DTR signal state. n=0: Ignores DTR signals. n=1: Ignores DTR signals but goes to on-line command mode when the change of DTR from ON to OFF is detected during data mode. n=2, and 3: Terminates the call and goes to command mode when the change of DTR from ON to OFF is detected during data mode. | 2 | | | | | | | | | | | | | | | | | | | | | | | | | | | | | | | | | | | | | | | | | | | | | | | | |
| &G | AT&Gn | Sets the guard tone transmission. n=0: No guard tone n=1: With guard tone of 550 Hz n=2: With guard tone of 1800 Hz | 0 | | | | | | | | | | | | | | | | | | | | | | | | | | | | | | | | | | | | | | | | | | | | | | | | |
| &P | AT&Pn | Sets the make ratio of pulse dialing. n=0: 39% (10pps) n=1: 33% (10pps) n=2: 33% (20pps) | 1 | | | | | | | | | | | | | | | | | | | | | | | | | | | | | | | | | | | | | | | | | | | | | | | | |
| &T | AT&Tn | Controls the loop back test mode. n=0: Ceases test mode n=1: Starts local analog loop back test (ALB) n=2 or 3: None n=4: Responds to the RDL test request n=5: Does not respond to the RDL test request n=6: Starts remote digital loop back test (RDL) n=7: Starts RDL self-diagnostic test. n=8: Starts ALB self-diagnostic test. | — | | | | | | | | | | | | | | | | | | | | | | | | | | | | | | | | | | | | | | | | | | | | | | | | |
| %E | AT%En | Selects automatic re-training function due to poor incoming conditions of the receive section. n=0: Automatic re-training is disabled. n=1: Automatic re-training is enabled. | 1 | | | | | | | | | | | | | | | | | | | | | | | | | | | | | | | | | | | | | | | | | | | | | | | | |

| CMD | Style | Function | Initial Value | Note |
|-----|-------|---|---------------|---|
| \L | AT\Ln | Checks kinds of line connection and returns the result n=0: Checks whether it's connected with a PBX (0-starting dialing) or directly connected to PSTN. n=1: Checks between pulse dialing line or tone dialing line | - | |
| \N | AT\Nn | Selects data control mode. n=0,1: Selects normal mode (without error correction). n=2,3,4,5: None n=6: Selects reliable mode. Disconnects the line when MNP connection is not available. n=7: Selects auto-reliable mode. Connects in normal mode when MNP connection is not available. | 7 | |
| \Q | AT\Qn | Selects the flow control between DTE and modem. n=0: No flow control (Connects in direct mode when AT\Nn=AT\N0 or AT\N1) n=1,2: None n=3: Bi-directional control by CTS/RTS | 3 | Only 1200/2400bps mode is available in direct mode. |
| \V | AT\Vn | Selects extended result code. n=0: Displays the normal result code. n=1: Displays the result code with the mode of the MNP connection. n=2, 3: None | 0 | |

Note : When the data rate between the DTE and the DCE is 9600bps and the normal mode is set, set the n-value to 3 in AT\Qn.

Note : Connecting in direct mode, a prior check to see if the modem on the remote side is also in a direct mode must be made.

Result Codes

Result Code Description :

The result code is returned to DTE after AT command is executed.

Two types of result codes are available and can be selected by the Vn command. It is possible to select whether the result code is returned or not by using the Qn command.

The format of 2 types of result codes is as follows:

In the case of number |Number|CR|_____

In the case of characters |CR|LF|Result Character string|CR|LF|_____

Result Code List :

| Number | Character string | Meaning |
|--------|------------------|--------------------------------------|
| 0 | OK | Command is correctly executed. |
| 1 | CONNECT | Connected. |
| 2 | RING | Call-in signal is detected. |
| 3 | NO CARRIER | Aborted the connection or on-hook |
| 4 | ERROR | Found the error in the command |
| 5 | CONNECT 1200 | Connected at 1200 bps |
| 6 | NO DIAL TONE | Dial tone cannot be detected. |
| 7 | BUSY | Busy tone is detected. |
| 8 | NO ANSWER | Silence state cannot be detected. |
| 10 | CONNECT 2400 | Connected at 2400 bps |
| 12 | CONNECT 9600 | Connected at 9600 bps in normal mode |
| 22 | CONNECT 1200/REL | Connected at 1200 bps in MNP mode |
| 23 | CONNECT 2400/REL | Connected at 2400 bps in MNP mode |
| 90 | EXT | Judges as PBX connection |
| 91 | DIRECT | Judges as direct connection |
| 92 | DTMF | Judges as tone dialing line |
| 93 | PULSE | Judges as pulse dialing line |

REGISTERS

S Register Setting :

In this modem, memory used as S registers is provided in RAM to set variables used for modem environment settings or to read modem status.

Normal operation is not guaranteed when register numbers not specified in this data sheet or parameters outside the specification are input.

(1) S register setting

The format to set S registers is as follows:

AT<Sn> = <d>

<n> specifies the register no. in decimal (0 to 27, 34, 35). <d> specifies the number to be set from decimal 0 to 255. If no number is specified at <n> and <d>, it is regarded as "0".

(2) S register reference

The format to refer to S registers is as follows:

ATS<n>

<n> specifies the register no. in decimal (0 to 27, 34, 35)

If no number is specified at <n>, it is regarded as "0".

S Register List :

Refer to the “Bit map S Register list” if the function is specified as “Bit map register”.

| Register No. | Set Range | Unit | Initial Value | Function |
|--------------|-----------|------------|---------------|--|
| 0 | 0-255 | time | 0 | Setting of the number to receive the ring signal in automatic receive mode. When set to “0”, automatic receive function is disabled. |
| 1 | 0-255 | time | 0 | The number of rings received |
| 2 | — | — | — | Not used |
| 3 | 0-127 | ASCII code | 13 | Carriage return code |
| 4 | 0-127 | ASCII code | 10 | Line feed code |
| 5 | 0-127 | ASCII code | 8 | Back space code |
| 6 | 4-255 | sec | 4 | Pause time from off-hook to start dialing (Only when setting ATX0, X1, and X3) |
| 7 | 1-115 | sec | 60 | Waiting time for carrier from the far end modem. The device is set to on-hook when no carrier is detected after the time specified. |
| 8 | 0-255 | sec | 2 | Pause time for dialing. It is referred when dial character <, > is used. |
| 9 | — | — | — | Not used |
| 10 | 1-255 | 1/10 sec | 14 | Carrier lost detection time The device is set to on-hook automatically when the lost of carrier signal is longer than the specified time. Carrier lost detection is invalid when 255 is set. |
| 11 | 1-255 | 1/100 sec | 9 | DTMF tone transmit time Sets DTMF transmit time. DTMF tone is continuously transmitted when set at 255. |
| 12 | — | — | — | Not used |
| 13 | — | — | — | Not used |
| 14 | — | — | 170 | Bit map register |
| 15 | — | — | — | Not used |
| 16 | — | — | 0 | Bit map register |
| 17 | — | — | — | Not used |
| 18 | 0-255 | sec | 0 | Timer for loop back test |
| 19 | — | — | — | Not used |
| 20 | — | — | — | Not used |
| 21 | — | — | 18 | Bit map register |
| 22 | — | — | 244 | Bit map register |
| 23 | — | — | 23 | Bit map register |
| 24~27 | — | — | — | Not used |
| 34 | 0-255 | dB | 2 | Sets the level attenuator of transmit carrier. When 15 to 255 is input, value is fixed to 15. |
| 35 | 0-255 | dB | 0 | Sets the sending level attenuator of DTMF signal. When 15 to 255 is input, value is fixed to 15. |

* Refer to the “Analog Interface” for the analog transmit level for S34 and S35.

* Waiting time for carrier from the far end modem set by S7 starts at a timing of off-hook.

Bit Map Register List :

| S14 | | | | |
|-----|---------------|-----------------------------------|---|---------|
| Bit | Initial value | Function enabled by "0" | Function enabled by "1" | Command |
| 7 | 1 | Answer mode | Originate mode | A, D |
| 6 | 0 | Not used | Not used | |
| 5 | 1 | Tone dial | Pulse dial | T, P |
| 4 | 0 | Pulse speed = 10pps | Pulse speed = 20pps | &P |
| 3 | 1 | Makes the result code the number. | Makes the result code the character string. | V |
| 2 | 0 | With the result code | No result code | Q |
| 1 | 1 | No echo back | With echo back | E |
| 0 | 0 | Not used | Not used | |

| S16 | | | | |
|-----|---------------|---|--|---------|
| Bit | Initial value | Function enabled by "0" | Function enabled by "1" | Command |
| 7 | 0 | Not used | Not used | |
| 6 | 0 | Stops analog loop back self-diagnostic. | Analog loop back self-diagnostic | &T8 |
| 5 | 0 | Stops remote digital loop back self-diagnostic. | Remote digital loop back self-diagnostic | &T7 |
| 4 | 0 | Stops remote digital loop back test. | Remote digital loop back test | &T6 |
| 3 | 0 | Not used | Not used | |
| 2 | 0 | Not used | Not used | |
| 1 | 0 | Not used | Not used | |
| 0 | 0 | Stops analog loop back test. | Analog loop back test | &T1 |

| S21 | | | | |
|-----|---------------|--------------------------------|---------------------------------------|-------------|
| Bit | Initial value | Function enabled by "0" | Function enabled by "1" | command |
| 7 | 0 | Not used | Not used | |
| 6 | 0 | Not used | Not used | |
| 5 | 0 | CD signal is always ON. | CD signal is ON by carrier detection. | &C |
| 4 | 1 | 0 <input type="checkbox"/> &DO | 1 <input type="checkbox"/> &D2 | &D |
| 3 | 0 | 0 <input type="checkbox"/> &D0 | 1 <input type="checkbox"/> &D1 | DTR Control |
| 2 | 0 | Not used | Not used | |
| 1 | 1 | Auto re-train disabled | Auto re-train enabled | %E |
| 0 | 0 | Not used | Not used | |

| S22 | | | | |
|-----|---------------|-------------------------------|-------------------------------|----------|
| Bit | Initial value | Function enabled by "0" | Function enabled by "1" | Command |
| 7 | 1 | Pulse dial make ration = 39% | Pulse dial make ration = 33% | &P |
| 6 | 1 | 0 <input type="checkbox"/> X0 | 1 <input type="checkbox"/> X1 | X |
| 5 | 1 | 0 <input type="checkbox"/> X0 | 1 <input type="checkbox"/> X1 | Extended |
| 4 | 1 | 0 <input type="checkbox"/> X0 | 1 <input type="checkbox"/> X1 | command |
| 3 | 0 | 0 <input type="checkbox"/> M0 | 1 <input type="checkbox"/> M1 | M |
| 2 | 1 | 0 <input type="checkbox"/> M0 | 1 <input type="checkbox"/> M1 | |
| 1 | 0 | Not used | Not used | |
| 0 | 0 | Not used | Not used | |

| S23 | | Function enabled by "0" | | | | Function enabled by "1" | | | | Command |
|-----|---------------|---|----------|----------------------------|--------|---|--------|----------------------------|--------|----------|
| Bit | Initial value | | | | | | | | | |
| 7 | 0 | 0 <input type="checkbox"/> | &G0 | 0 <input type="checkbox"/> | &G1 | 1 <input type="checkbox"/> | &G2 | 1 <input type="checkbox"/> | &G3 | &G |
| 6 | 0 | 0 <input type="checkbox"/> | | 1 <input type="checkbox"/> | | 0 <input type="checkbox"/> | | 1 <input type="checkbox"/> | | |
| 5 | 0 | 0 <input type="checkbox"/> | Parity | 0 <input type="checkbox"/> | Parity | 1 <input type="checkbox"/> | Parity | 1 <input type="checkbox"/> | Parity | |
| 4 | 1 | 0 <input type="checkbox"/> | Even No. | 1 <input type="checkbox"/> | Mark | 0 <input type="checkbox"/> | Odd No | 1 <input type="checkbox"/> | None | |
| 3 | 0 | Not used | | | | Not used | | | | |
| 2 | 1 | Not used | | | | Not used | | | | |
| 1 | 1 | Not used | | | | Not used | | | | |
| 0 | 1 | Ignores the remote digital loop back request. | | | | Complies to the remote digital loop back request. | | | | &T4, &T5 |

TYPICAL APPLICATION CIRCUITS

Analog Interface

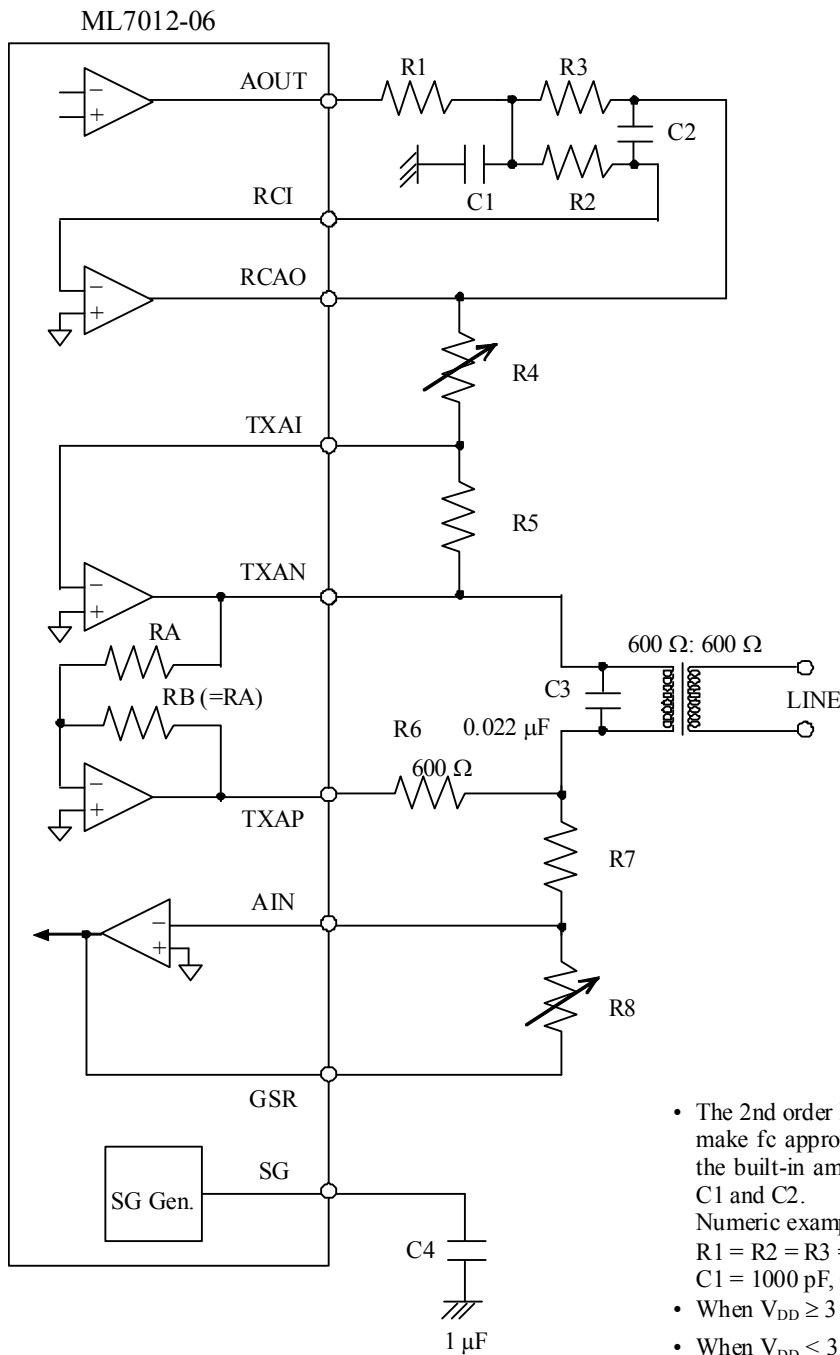

- The 2nd order LPF should be built to make f_c approximately 5 kHz using the built-in amplifier, R1 to R3, and C1 and C2.
 Numeric examples:
 $R1 = R2 = R3 = 68 \text{ k}\Omega$
 $C1 = 1000 \text{ pF}$, $C2 = 220 \text{ pF}$
- When $V_{DD} \geq 3 \text{ V}$, $R5/R4 \leq 2$
- When $V_{DD} < 3 \text{ V}$, $R5/R4 \leq 1.6$

AN EXAMPLE OF LEVEL DIAGRAM

1. Modem transmission, $V_{DD} \geq 3\text{ V}$
AOUT = -20dBm, RCAO = -20dBm, TXAN = -14dBm, TXAP = -14dBm, LINE = -16dBm
(S34 = 2dB(default), R5/R4 = 2, Loss at a transformer = 2dB)
2. DTMF Transmission, $V_{DD} \geq 3\text{ V}$ DTMF high group level, DTMF low group level is approx. 1dB lower than below.
AOUT = -14.5dBm, RCAO = -14.5dBm, TXAN = -8.5dBm, TXAP = -8.5dBm, LINE = -10.5dBm
(S35 = 0dB(default), R5/R4 = 2, Loss at a transformer = 2dB)
3. Modem transmission, $V_{DD} \geq 2.7\text{ V}$
AOUT = -20dBm, RCAO = -20dBm, TXAN = -15.9dBm, TXAP = -15.9dBm, LINE = -17.9dBm
(S34 = 2dB(default), R5/R4 = 1.6, Loss at a transformer = 2dB)
4. DTMF Transmission, $V_{DD} \geq 2.7\text{ V}$ DTMF high group level, DTMF low group level is approx. 1dB lower than below.
AOUT = -14.5dBm, RCAO = -14.5dBm, TXAN = -10.4dBm, TXAP = -10.4dBm, LINE = -12.4dBm
(S35 = 0dB(default), R5/R4 = 1.6, Loss at a transformer = 2dB)
5. Modem receive (max.)
LINE = -9dBm, at connection of R6 and R7 = -11dBm, GSR = -15dBm,
(R8/R7 = 0.63 = -4dB, Loss at a transformer = 2dB)
6. Modem receive (min.)
LINE = -40dBm, at connection of R6 and R7 = -42dBm, GSR = -46dBm,
(R8/R7 = 0.63 = -4dB, Loss at a transformer = 2dB)

CONNECTION OF CRYSTAL OSCILLATOR

Connect a 11.0592 MHz crystal and a 1 M Ω feedback resistor between OSC0 and OSC1.

The values of capacitors C₀₁ and C₀₂ connected between OSC0 and GND, and OSC1 and GND vary with the load capacitance of the crystal and the wiring capacitance of the board. Set the values by the crystal manufacturer's matching evaluation.

If an external clock is used, input it to OSC0.

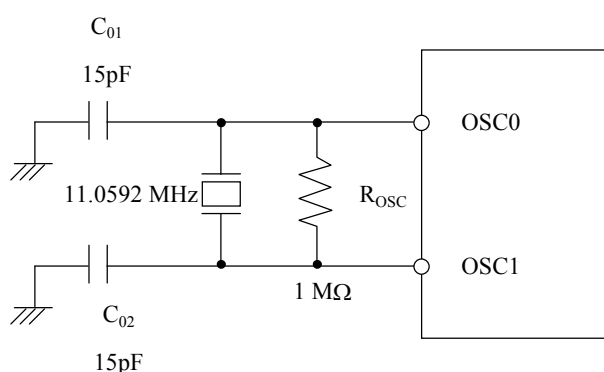

REVISION HISTORY

| Document No. | Date | Page | | Description |
|----------------|--------------|------------------|-----------------|--|
| | | Previous Edition | Current Edition | |
| FEDL7012-06-01 | May 2004 | – | – | First edition |
| FEDL7012-06-02 | Jun 28, 2004 | 1 | 1 | Literal brush-up of descriptions under GENERAL DESCRIPTION |
| | | 1 | 1 | Literal brush-up of descriptions under FEATURES |
| | | 4 | 4 | Literal brush-up of descriptions under STD pin description |
| | | 11 | 11 | Correction of ATD! function |
| | | 12 | 12 | Functional description alternation for AT&T0 |
| | | 13 | 13 | Alternation of Note for AT\Qn setting in normal mode. |
| | | 17 | 17 | Correction of functional descriptions for bit-7 and bit-6 of S21 bit map register. |

NOTICE

No copying or reproduction of this document, in part or in whole, is permitted without the consent of LAPIS Semiconductor Co., Ltd.

The content specified herein is subject to change for improvement without notice.

The content specified herein is for the purpose of introducing LAPIS Semiconductor's products (hereinafter "Products"). If you wish to use any such Product, please be sure to refer to the specifications, which can be obtained from LAPIS Semiconductor upon request.

Examples of application circuits, circuit constants and any other information contained herein illustrate the standard usage and operations of the Products. The peripheral conditions must be taken into account when designing circuits for mass production.

Great care was taken in ensuring the accuracy of the information specified in this document. However, should you incur any damage arising from any inaccuracy or misprint of such information, LAPIS Semiconductor shall bear no responsibility for such damage.

The technical information specified herein is intended only to show the typical functions of and examples of application circuits for the Products. LAPIS Semiconductor does not grant you, explicitly or implicitly, any license to use or exercise intellectual property or other rights held by LAPIS Semiconductor and other parties. LAPIS Semiconductor shall bear no responsibility whatsoever for any dispute arising from the use of such technical information.

The Products specified in this document are intended to be used with general-use electronic equipment or devices (such as audio visual equipment, office-automation equipment, communication devices, electronic appliances and amusement devices).

The Products specified in this document are not designed to be radiation tolerant.

While LAPIS Semiconductor always makes efforts to enhance the quality and reliability of its Products, a Product may fail or malfunction for a variety of reasons.

Please be sure to implement in your equipment using the Products safety measures to guard against the possibility of physical injury, fire or any other damage caused in the event of the failure of any Product, such as derating, redundancy, fire control and fail-safe designs. LAPIS Semiconductor shall bear no responsibility whatsoever for your use of any Product outside of the prescribed scope or not in accordance with the instruction manual.

The Products are not designed or manufactured to be used with any equipment, device or system which requires an extremely high level of reliability the failure or malfunction of which may result in a direct threat to human life or create a risk of human injury (such as a medical instrument, transportation equipment, aerospace machinery, nuclear-reactor controller, fuel-controller or other safety device). LAPIS Semiconductor shall bear no responsibility in any way for use of any of the Products for the above special purposes. If a Product is intended to be used for any such special purpose, please contact a ROHM sales representative before purchasing.

If you intend to export or ship overseas any Product or technology specified herein that may be controlled under the Foreign Exchange and the Foreign Trade Law, you will be required to obtain a license or permit under the Law.

Copyright 2011 LAPIS Semiconductor Co., Ltd.