

ATLANTIC VERSION TERMINATOR INTERFACE ADAPTER	PART NUMBER	REVISION	DESCRIPTION	FEED TYPE	APPLICATOR STYLE CONVERSION CHART						
					CONVERT TO	PART NUMBERS REQUIRED					
	2150377-2	A	FINE CRIMP HEIGHT ADJUST	PNEUMATIC	-	-	-	-	-	-	
	2150377-5	A	FINE CRIMP HEIGHT ADJUST	SERVO LATCH PLATE <sup>4</sup>	SERVO LATCH PLATE	2119951-1	1901697-1	8-2150377-5	-	-	2168400-7 (QUANTITY 2)
					SMART APPLICATOR	2161326-1	-	8-2150377-4	-	-	-
	2150377-6	A	NON-CRIMP HEIGHT ADJUST	SERVO LATCH PLATE <sup>11</sup>	PNEUMATIC FEED	2119950-1	2119792-2	-	2119641-1	-	2063440-2
					-	-	-	-	-	-	-
	2150377-7	A	FINE CRIMP HEIGHT ADJUST	NONE	-	-	-	-	-	-	
	7-2150377-7	A	CRIMP TOOLING KIT	-	-	-	-	-	-	-	

APPLICATOR DATA		
CRIMP	SIZE	TYPE
WIRE	2.29 mm [.090]	F
INSUL	4.06 mm [.160]	F
APPL INSTRUCTIONS 408-10390		

TERMINAL DATA: TE TERMINAL		TE CRIMP SPECIFICATION	
TERMINAL NAME: TAB MIC MK II			
WIRE STRIP LENGTH		INSULATION DIAMETER RANGE	
3.50-4.50 mm [.138-.177 IN]		∅2.16-3.43 mm [.085-.135 IN]	
TERMINAL APPLICATION SPECIFICATION	114-5072		
TERMINALS APPLIED <sup>10</sup>			
TE TERMINAL	TE TERMINAL	TE TERMINAL	TE TERMINAL
172777-1	172777-2	172777-3	172777-4

WIRE SIZE	CRIMP HEIGHT mm [INCH]	CRIMP HEIGHT REFERENCE SETTING
14 AWG OR 2.00mm2	1.78 +/- 0.05 [.070 +/- .002]	4.4
16 AWG OR 1.25mm2	1.50 +/- 0.05 [.059 +/- .002]	7.3
0.5+0.85mm2 OR 20+18 AWG	1.50 +/- 0.05 [.059 +/- .002]	7.4
0.5+0.5mm2 OR 20+20 AWG	1.50 +/- 0.05 [.059 +/- .002]	7.2
18 AWG OR 0.85mm2	1.34 +/- 0.05 [.053 +/- .002]	9.2
20 AWG OR 0.50mm2	1.30 +/- 0.05 [.051 +/- .002]	9.4

- <sup>1</sup> RECOMMENDED SPARE PARTS
- <sup>2</sup> GREASE BEARING SURFACES LIGHTLY
- 3. LUBRICATE DAILY PER THE APPLICATOR INSTRUCTION SHEET SUPPLIED WITH THE APPLICATOR.
- <sup>4</sup> APPLICATOR SPECIFIC DATA TO BE ENTERED INTO BLANK MEMORY CHIP AT ASSEMBLY. SEE BELOW FOR PART NUMBER:  
 PNEUMATIC FEED WITH "SMART APPLICATOR" CONVERSION: 8-2150377-4  
 SERVO FEED WITH "FINE CRIMP HEIGHT ADJUST": 8-2150377-5  
 SERVO FEED WITH "NON-CRIMP HEIGHT ADJUST": 8-2150377-6
- 5. ADJUSTMENT OF THE STRIPPER MAY BE REQUIRED WHEN MOVING THE APPLICATOR BETWEEN BENCH AND LEADMAKER APPLICATIONS.
- <sup>6</sup> APPLY PART NUMBER 1-23419-5 LOCTITE TO THREADS OF ITEMS 62, 180 & 242. FOR -6 ONLY APPLY PART NUMBER 1-23419-5 LOCTITE TO THREADS OF ITEMS 37, 180 & 242.
- <sup>7</sup> GREASE THREADS, GROOVE AND O-RING ON ITEMS 35 & 252.
- <sup>8</sup> MAGNET, ITEM 166 MUST BE ORIENTED CORRECTLY IN ORDER TO PROPERLY ACTUATE THE COUNTER.
- <sup>9</sup> CRIMP HEIGHT REFERENCE SETTING WAS THE SETTING USED WHEN THE APPLICATOR WAS QUALIFIED AT THE FACTORY. ADJUSTMENT MAY BE NECESSARY WHEN RUNNING APPLICATOR IN THE FIELD.
- <sup>10</sup> TERMINAL PITCH NOT COMPATIBLE WITH MECHANICAL FEED.
- <sup>11</sup> WHEN ASSEMBLING -6 NON-CRIMP HEIGHT ADJUST APPLICATOR USE SHIM PACK 2119957-2 TO ALIGN APPLICATOR'S MAXIMUM WIRE CRIMP HEIGHT AT NORMAL TERMINATOR SHUT HEIGHT.

**\*WARNING**  
 ON INSTALLATION, SET WIRE DISC, ITEM 40 TO LARGEST WIRE SIZE SETTING. USE OF SETTINGS BELOW MINIMUM REQUIRED CRIMP HEIGHT SETTING WILL CAUSE DAMAGE TO CRIMP TOOLING.

-	-	1	-	-	2119957-2	APPLICATOR SHIM PACK	260
-	1	-	1	1	8-21084-0	O-RING, .676 ID, .070 DIA. MAT.	252
-	-	-	-	1	2119640-1	PUSH ROD, AIR FEED	250
-	-	-	-	1	2079988-1	BUSHING, LCH5-12, MISUMI	249
-	-	-	-	1	2119641-1	FEED CAM, AIR FEED	248
-77	-7	-6	-5	-2	PART NO	DESCRIPTION	ITEM NO

**ATLANTIC VERSION**  
 Shown on sheets 1 of 4 & 2 of 4  
 (Pacific version shown on sheets 3 of 4 & 4 of 4)

SET UP GAUGE	LOC	DIST	REVISIONS					
2119599-2	A	66	P	LTN	DESCRIPTION	DATE	OWN	APVD
			A		RELEASED	19NOV2013	LG	TE

-	1	-	1	1	2119798-1	DETENT PIN	247
-	1	-	1	1	1-22279-3	SPRING, COMPRESSION	246
-	-	1	-	-	2119759-1	RAM, AMP STYLE, END FEED, NON-ADJUST	245
-	1	1	1	1	2119082-9	CAM, SNAIL, INSULATION ADJUSTMENT	244
-	1	1	1	1	2079764-1	WASHER, WAVE SPRING, CREST-TO-CREST	243
<sup>6</sup>	-	1	1	1	2119083-1	RETAINER, INSULATION DIAL	242
-	-	2	2	-	2168400-7	SHCS, LOW HEAD, RoHS, M5 X 10	240
-	-	-	-	1	2063440-2	AIR FEED MODULE	238
-	-	1	1	-	2119740-2	TAG, IDENTIFICATION	213
-	-	REF	REF	-	1901697-1	FEED FINGER ASSEMBLY, EF	183
<sup>6</sup>	-	1	1	1	1-1976055-1	STANDOFF, HOLD-DOWN	180
-	1	1	1	1	6-993111-6	PIN, SLOTTED SPRING 3.0 X 14.0	177
-	1	1	1	1	8-22280-7	SPRING, COMPRESSION	176
-	1	1	1	1	1752353-2	GUIDE PIN, HOLDDOWN	175
-	1	1	1	1	1901680-2	GUIDE PIN, HOLDDOWN	174
-	-	-	-	2	21045-3	RING, RETAIN, EXTERN, 3/16 CRESCENT	172
-	1	1	1	1	994969-1	MAGNET, RARE EARTH HIGH ENERGY	166
-	REF	REF	REF	REF	994970-2	COUNTER, MAGNETIC	164
-	-	-	-	1	240638-1	SPRING, FEED FINGER	163
-	-	-	-	1	3-23627-7	PIN, RETAIN, GRVD, 3/16 X .854	137
-	-	REF	REF	-	SEE NOTE 4	MEMORY CHIP, PROGRAMMED	135
-	-	1	1	-	1633743-1	SERVO FEED LATCH ASM	133
-	1	1	1	1	455888-5	SPACER, CRIMPER	82
-	1	1	1	1	2119791-9	DEPRESSOR, WIRE	73
-	1	1	1	1	2119956-2	DOCUMENTATION PACKAGE	71
-	2	2	2	2	2-18032-2	SCR, SET, FLT POINT M3 X 10.0	70
-	1	-	-	1	2119740-1	TAG, IDENTIFICATION	67
-	2	2	2	2	2168078-1	SCREW, DRIVE, RH, RoHS, 2 x .188	66
-	1	1	1	1	1901681-1	HOLDDOWN, TERMINAL	65
-	2	2	2	2	2168400-5	SHCS, LOW HEAD, RoHS, M4 X 20	64
<sup>6</sup>	-	1	-	1	2119793-1	LIMITER, ADJUSTMENT BOLT	63
-	3	-	3	3	992763-5	SCR, SET, SOC, CONE POINT, M3 X 4.0	62
-	1	1	1	1	2079383-4	SCR, BHSC, RoHS (M4 X 8)	60
-	3	3	3	3	2168400-4	SHCS, LOW HEAD, RoHS, M4 X 8	57
-	2	2	2	2	2168083-9	SCR, SKT HD CAP, RoHS, M4 X 20	56
-	2	2	2	2	5018030-2	NUT, HEX, REG, RoHS, M4	55
-	2	2	2	2	5018030-1	NUT, HEX, REG, RoHS, M3	54
-	2	2	2	2	986965-8	NUT, LOCK, HEX, TORQUE (M4)	53
-	1	1	1	1	1-5018030-0	NUT, HEX, REG, RoHS, M3.5	52
-	-	-	-	1	2119792-2	PAWL, EF, AIR	51
-	-	-	-	1	18023-9	SCR, SKT HD CAP M4 X 6.0	49
-	1	1	1	1	2119655-5	APPLICATOR BASIC ASSEMBLY, EF	46
-	1	-	1	1	2119369-1	RAM, AMP STYLE, END FEED	44
-	1	1	1	1	2079383-7	SCR, BHSC, RoHS (M8 X 25)	41
-	1	-	1	1	2119645-1	DISC, NUMBERED FA WIRE ADJUSTMENT	40
-	1	-	1	1	2119957-1	APPLICATOR SHIM PACK	39
<sup>6</sup>	-	1	1	1	1-2119644-2	RAM WASHER, PRECISION	38
-	1	1	1	1	2119085-1	FA HEAD, ATLANTIC STYLE	37
-	1	-	1	1	2119092-1	BOLT, ADJUSTMENT	35
-	7	7	7	7	1-18028-2	WASHER, FLAT, REG M4	33
-	2	2	2	2	2168083-9	SCR, SKT HD CAP, RoHS, M4 X 20	31
-	2	2	2	2	1-2168083-0	SCR, SKT HD CAP, RoHS, M4 X 10	29
-	1	1	1	1	240639-1	STRIPPER (MACHINING)	27
-	2	2	2	2	1320906-1	STUD, THREADED	25
-	1	1	1	1	1752371-8	PLATE, STRIP GUIDE	24
-	1	1	1	1	240825-7	PLATE, STRIP HOLD DOWN	23
-	2	2	2	2	2-22281-3	SPRING, COMPRESSION	22
-	1	1	1	1	1752373-4	DRAG	20
-	2	2	2	2	1901259-6	GUIDE, LOWER STRIP	18
-	4	4	4	4	1-2079383-1	SCR, BHSC, RoHS (M6 X 12)	17
-	1	1	1	1	6-240641-8	SPACER	16
-	1	1	1	1	1752360-1	SPACER, HOLD-DOWN	13
<sup>1</sup>	-	1	1	1	240833-1	PLATE, REAR SHEAR	11
-	-	-	-	-	-	-	10
<sup>1</sup>	-	1	1	1	690482-5	PLATE, FRONT SHEAR	9
<sup>1</sup>	1	1	1	1	1-1333217-3	ANVIL, EF .090	8
<sup>1</sup>	-	1	1	1	2217206-7	BLADE, SLUG	7
-	-	-	-	-	-	-	6
-	1	1	1	1	6-240641-8	SPACER	5
-	1	1	1	1	238009-1	BLOCK, FL CRIMPER SPACER	4
<sup>1</sup>	1	1	1	1	7-1633961-6	CRIMPER, INSULATION F PREMIUM	3
-	-	-	-	-	-	-	2
<sup>1</sup>	1	1	1	1	4-456406-7	CRIMPER, WIRE PREMIUM	1
-77	-7	-6	-5	-2	PART NO	DESCRIPTION	ITEM NO

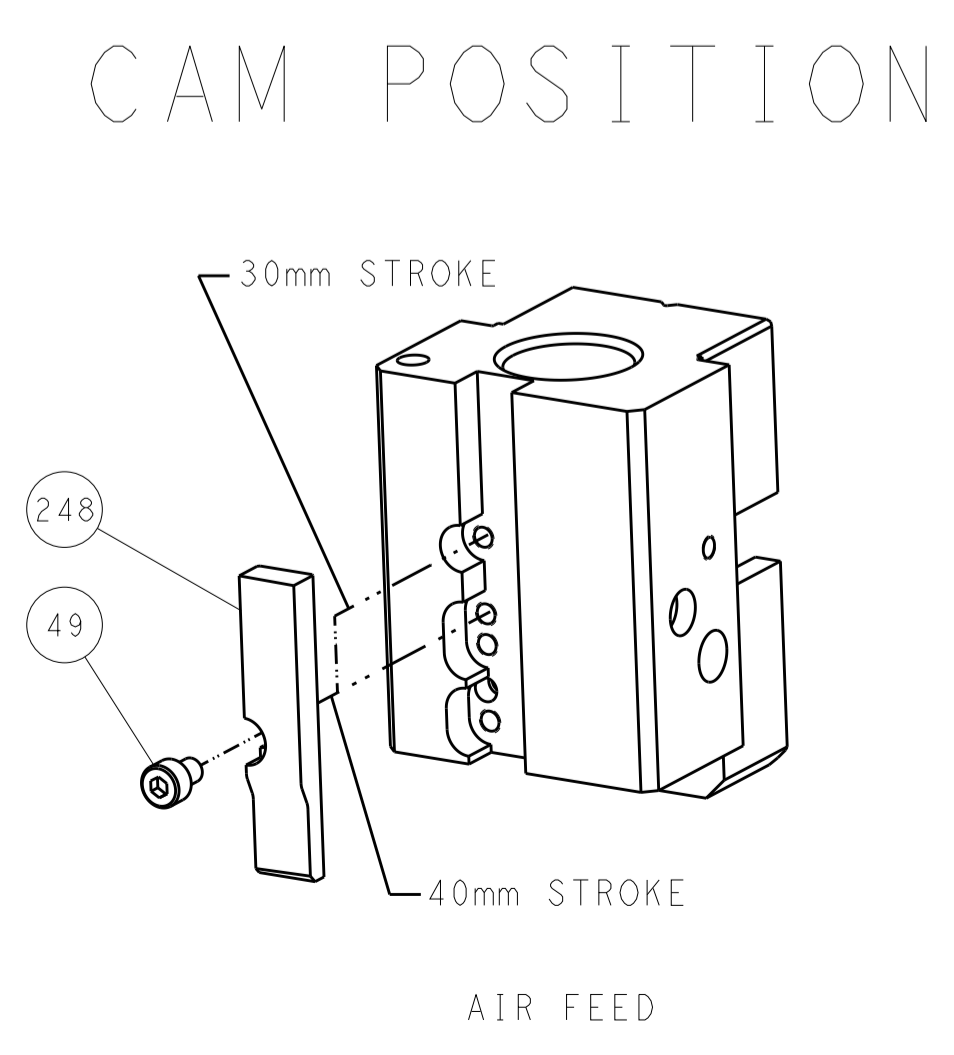
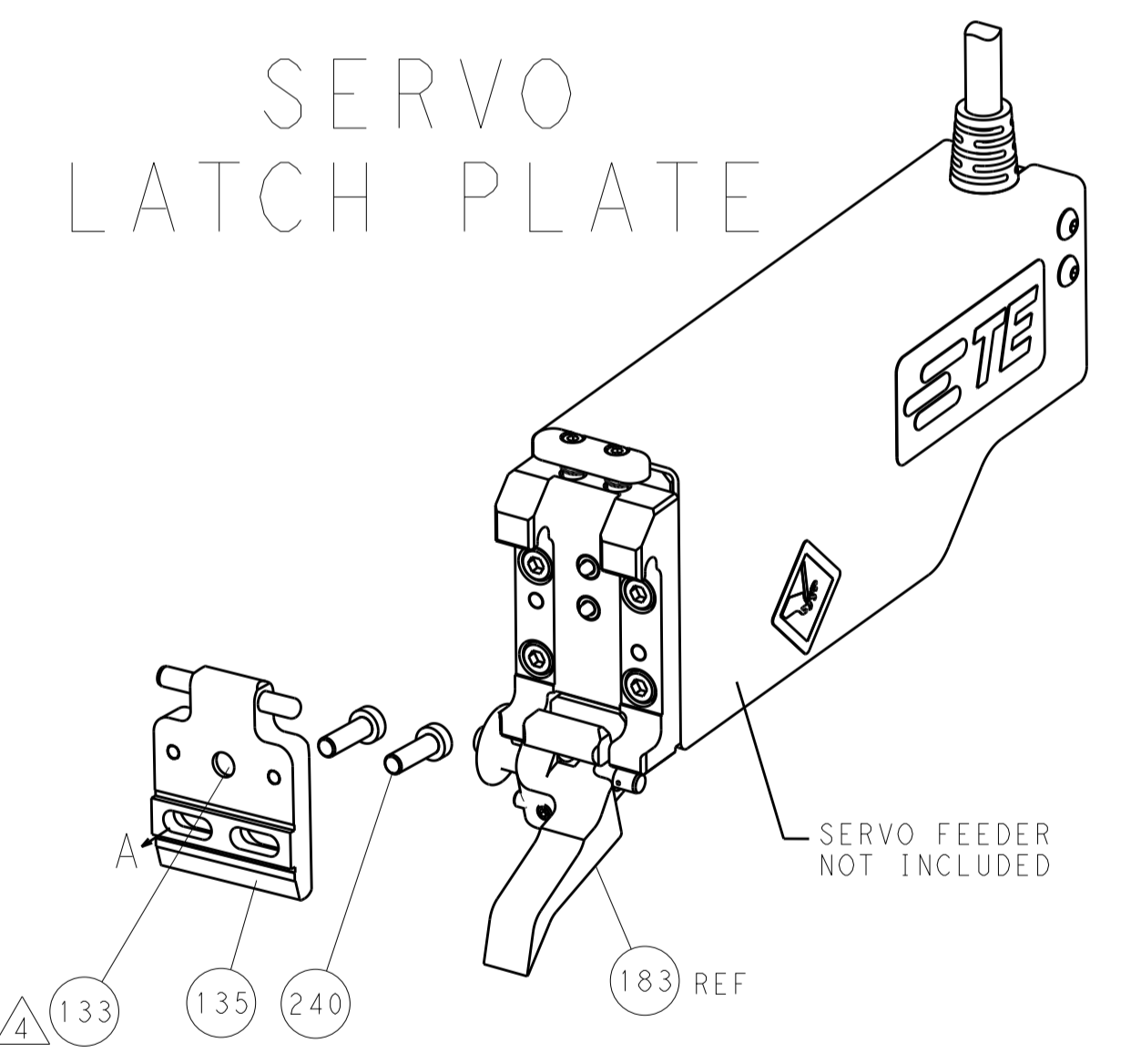
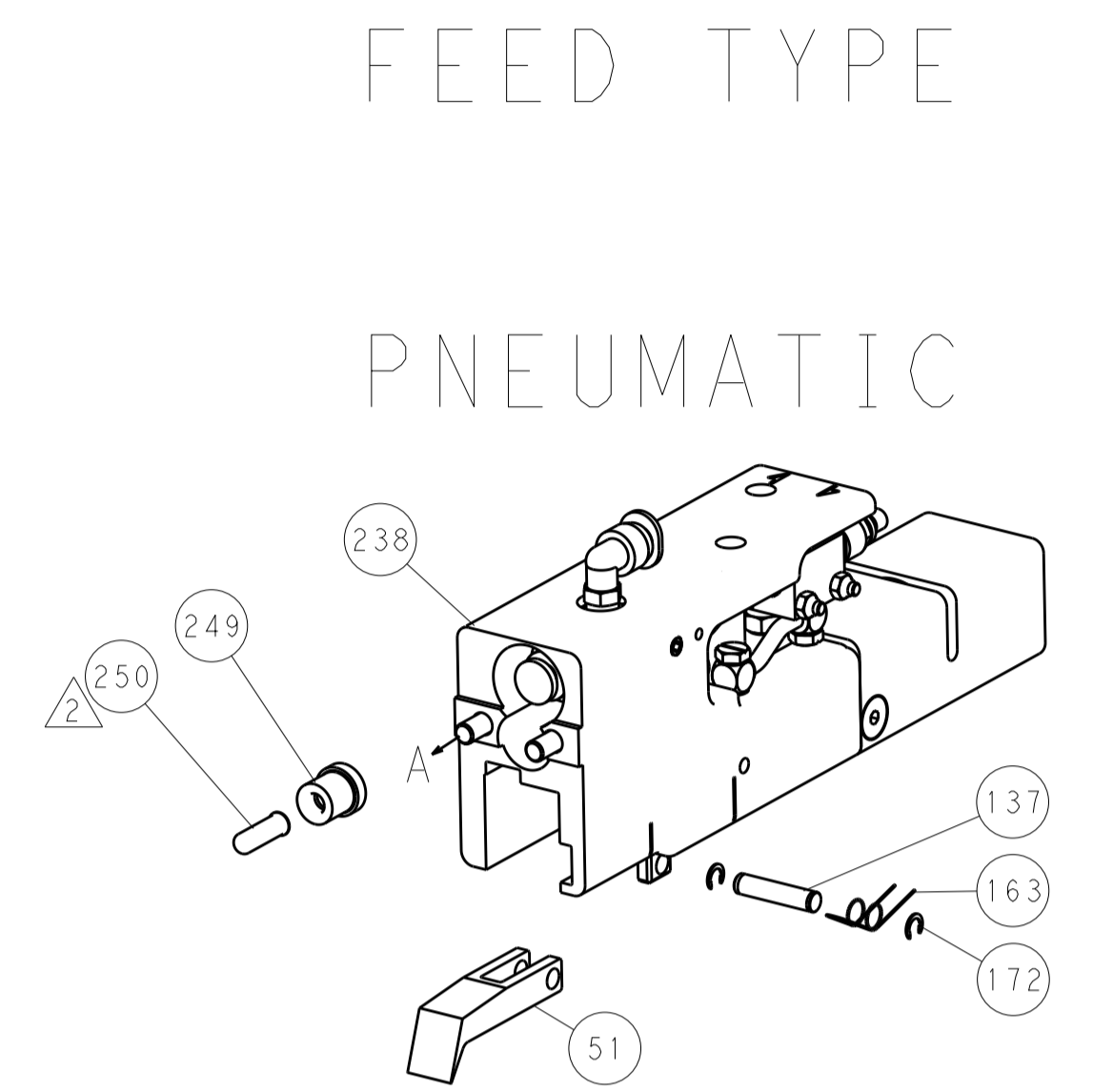
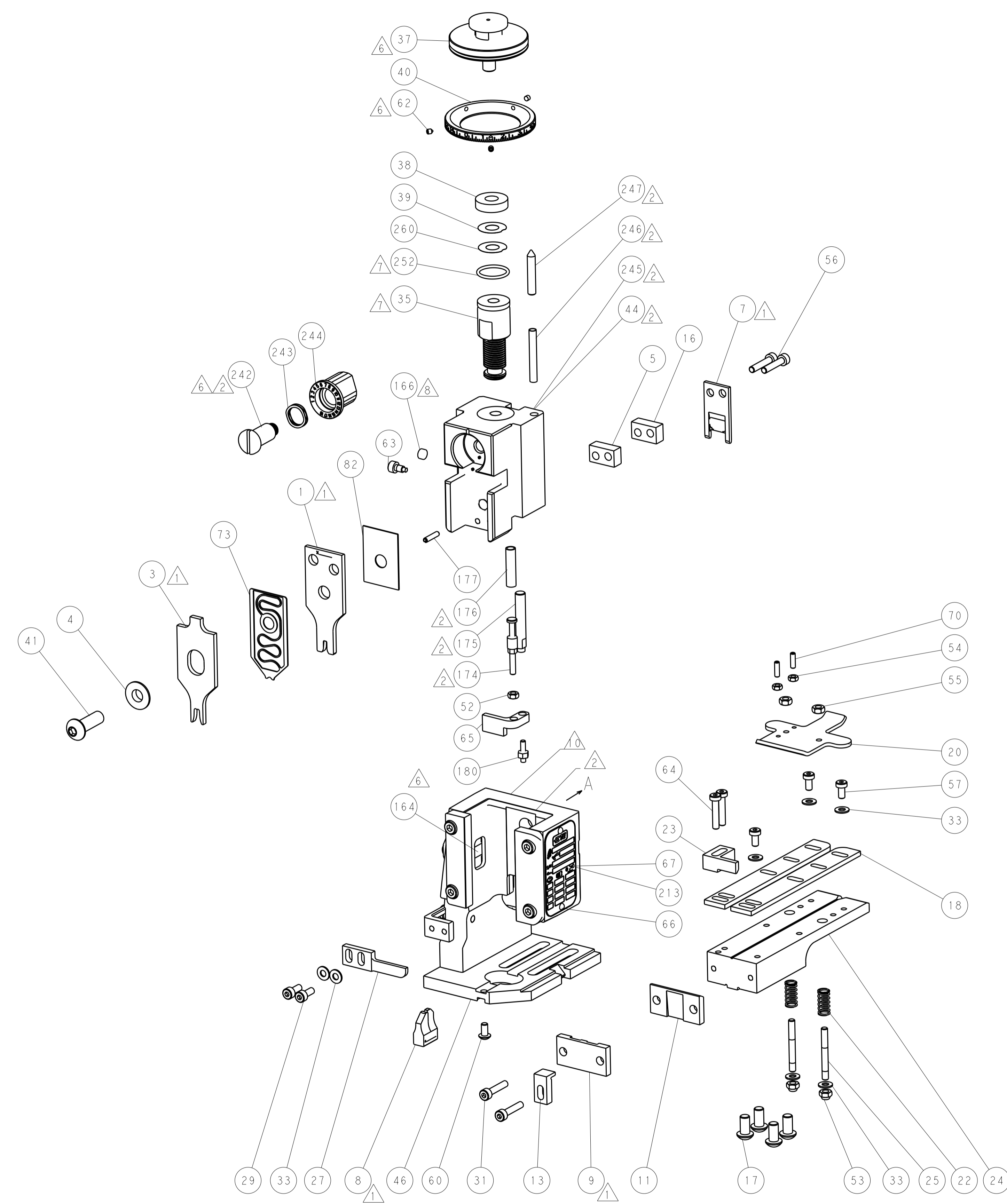
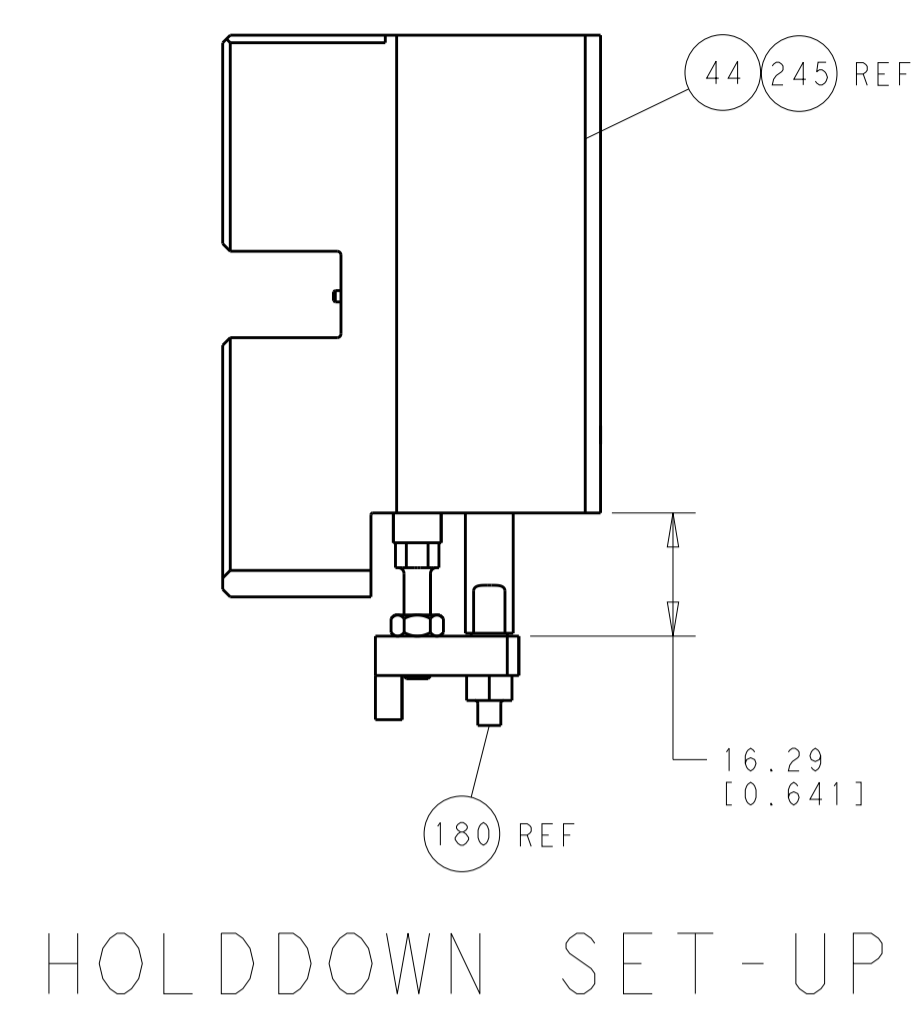

DIMENSIONS:		TOLERANCES UNLESS OTHERWISE SPECIFIED:		DWN		TE Connectivity	
mm	0 PLC ±.5	1 PLC ±.3	2 PLC ±.13	3 PLC ±.013	4 PLC ±.0001	ANGLES ±.0001	FINISH
MATERIAL		FINISH		WEIGHT		SCALE	
-		-		-		1:1	
Customer Accessible Production Drawing				SHEET 1 OF 4			

LOC	DIST	REV	DATE	BY	APPV
A	66				
REVISIONS			DESCRIPTION	DATE	BY
			SEE SHEET 1		



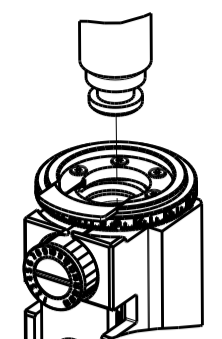

**ATLANTIC VERSION**  
 Shown on sheets 1 of 4 & 2 of 4  
 (Pacific version shown on sheets 3 of 4 & 4 of 4)





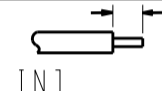



<small>THIS DRAWING IS UNPUBLISHED. RELEASED FOR PUBLICATION BY TYCO ELECTRONICS CORPORATION. ALL RIGHTS RESERVED.</small>		DWN: 04OCT2013 CHK: G. BAILEY APVD: M. CLIFFORD	NAME: Ocean End Feed Applicator SIZE: A1 CAGE CODE: 00779 DRAWING NO: 2150377	TE Connectivity Harrisburg, PA 17105-3608
DIMENSIONS: mm TOLERANCES UNLESS OTHERWISE SPECIFIED: 0 PLC ±0.5 1 PLC ±0.13 3 PLC ±0.013 4 PLC ±0.0001 ANGLES ±0.0001	FINISH:	WEIGHT:	SCALE: 1:1 SHEET: 2 of 4 REV: A	RESTRICTED TO:

PACIFIC VERSION TERMINATOR INTERFACE ADAPTER	PART NUMBER	REVISION	DESCRIPTION	FEED TYPE	APPLICATOR STYLE CONVERSION CHART						
					CONVERT TO	PART NUMBERS REQUIRED					
	2-2150377-2	A	FINE CRIMP HEIGHT ADJUST	PNEUMATIC	SERVO LATCH PLATE	2119951-1	1901697-1	8-2150377-5	-	-	2168400-7 (QUANTITY 2)
					SMART APPLICATOR	2161326-1	-	8-2150377-4	-	-	-
	2-2150377-5	A	FINE CRIMP HEIGHT ADJUST	SERVO LATCH PLATE 	-	-	-	-	-	-	-
					PNEUMATIC FEED	2119950-1	2119792-2	-	2119641-2	-	2063440-2
2-2150377-7	A	FINE CRIMP HEIGHT ADJUST	NONE	-	-	-	-	-	-	-	
7-2150377-7	A	CRIMP TOOLING KIT	-	-	-	-	-	-	-	-	

APPLICATOR DATA		
CRIMP	SIZE	TYPE
WIRE	2.29 mm [ .090 ]	F
INSUL	4.06 mm [ 1.60 ]	F
APPL INSTRUCTIONS 408-10390 		

TERMINAL DATA: TE TERMINAL		TE CRIMP SPECIFICATION	
TERMINAL NAME: TAB MIC MK II			
WIRE STRIP LENGTH		INSULATION DIAMETER RANGE	
3.50-4.50 mm [ 1.38-.177 IN ]		∅2.16-3.43 mm [ .085-.135 IN ]	
TERMINAL APPLICATION SPECIFICATION	114-5072	-	-
TERMINALS APPLIED 			
TE TERMINAL	TE TERMINAL	TE TERMINAL	TE TERMINAL
172777-1	172777-2	172777-3	172777-4

WIRE SIZE	CRIMP HEIGHT mm [INCH]	CRIMP HEIGHT REFERENCE SETTING 
14 AWG OR 2.00mm2	1.78 +/- 0.05 [ .070 +/- .002 ]	4.4
16 AWG OR 1.25mm2	1.50 +/- 0.05 [ .059 +/- .002 ]	7.3
0.5+0.85mm2 OR 20+18 AWG	1.50 +/- 0.05 [ .059 +/- .002 ]	7.4
0.5+0.5mm2 OR 20+20 AWG	1.50 +/- 0.05 [ .059 +/- .002 ]	7.2
18 AWG OR 0.85mm2	1.34 +/- 0.05 [ .053 +/- .002 ]	9.2
20 AWG OR 0.50mm2	1.30 +/- 0.05 [ .051 +/- .002 ]	9.4

-  RECOMMENDED SPARE PARTS
-  GREASE BEARING SURFACES LIGHTLY
- 3. LUBRICATE DAILY PER THE APPLICATOR INSTRUCTION SHEET SUPPLIED WITH THE APPLICATOR.
-  APPLICATOR SPECIFIC DATA TO BE ENTERED INTO BLANK MEMORY CHIP AT ASSEMBLY. SEE BELOW FOR PART NUMBER:  
 PNEUMATIC FEED WITH "SMART APPLICATOR" CONVERSION: 8-2150377-4  
 SERVO FEED WITH "FINE CRIMP HEIGHT ADJUST": 8-2150377-5
- 5. ADJUSTMENT OF THE STRIPPER MAY BE REQUIRED WHEN MOVING THE APPLICATOR BETWEEN BENCH AND LEADMAKER APPLICATIONS.
-  APPLY PART NUMBER 1-23419-5 LOCTITE TO THREADS OF ITEMS 62, 180 & 242.
-  GREASE THREADS, GROOVE AND O-RING ON ITEMS 139 & 153.
-  MAGNET, ITEM 166 MUST BE ORIENTED CORRECTLY IN ORDER TO PROPERLY ACTUATE THE COUNTER.
-  CRIMP HEIGHT REFERENCE SETTING WAS THE SETTING USED WHEN THE APPLICATOR WAS QUALIFIED AT THE FACTORY. ADJUSTMENT MAY BE NECESSARY WHEN RUNNING APPLICATOR IN THE FIELD.
-  TERMINAL PITCH NOT COMPATIBLE WITH MECHANICAL FEED.

**\*WARNING**  
 ON INSTALLATION, SET WIRE DISC, ITEM 40 TO LARGEST WIRE SIZE SETTING. USE OF SETTINGS BELOW MINIMUM REQUIRED CRIMP HEIGHT SETTING WILL CAUSE DAMAGE TO CRIMP TOOLING.

-	1	1	1	2119782-1	FINE ADJUST HEAD ASM, PACIFIC STYLE	251	
-	-	-	1	2119640-1	PUSH ROD, AIR FEED	250	
-	-	-	1	2079988-1	BUSHING, LCH5-12, MISUMI	249	
-	77	27	25	22	PART NO	DESCRIPTION	ITEM NO

**PACIFIC VERSION**  
 Shown on sheets 3 of 4 & 4 of 4  
 (Atlantic version shown on sheets 1 of 4 & 2 of 4)

SET UP GAUGE	LOC	DIST	REVISIONS			
2119599-2	A	66	REV	DATE	BY	APPV
-	-	-	1	SEE SHEET 1	-	-

-	1	1	1	1-22279-3	SPRING, COMPRESSION	246	
-	1	1	1	2119082-9	CAM, SNAIL, INSULATION ADJUSTMENT	244	
-	1	1	1	2079764-1	WASHER, WAVE SPRING, CREST-TO-CREST	243	
-	1	1	1	2119083-1	RETAINER, INSULATION DIAL	242	
-	-	2	-	2168400-7	SHCS, LOW HEAD, RoHS, M5 X 10	240	
-	-	-	1	2063440-2	AIR FEED MODULE	238	
-	-	1	-	2119740-2	TAG, IDENTIFICATION	213	
-	4	4	4	2079383-9	SCR, BHSC, RoHS (M6 X 20)	186	
-	-	REF	-	1901697-1	FEED FINGER ASSEMBLY, EF	183	
-	1	1	1	1-1976055-1	STANDOFF, HOLD-DOWN	180	
-	1	1	1	6-993111-6	PIN, SLOTTED SPRING 3.0 X 14.0	177	
-	1	1	1	8-22280-7	SPRING, COMPRESSION	176	
-	1	1	1	1752353-2	GUIDE PIN, HOLDDOWN	175	
-	1	1	1	1901680-2	GUIDE PIN, HOLDDOWN	174	
-	-	-	2	21045-3	RING, RETAIN, EXTERN, 3/16 CRESCENT	172	
-	-	-	1	994969-1	MAGNET, RARE EARTH HIGH ENERGY	166	
-	REF	REF	REF	994970-2	COUNTER, MAGNETIC	164	
-	-	-	1	240638-1	SPRING, FEED FINGER	163	
-	1	1	1	8-21084-1	O-RING, .801 ID, .070 DIA. MAT.	153	
-	-	-	1	2119641-2	FEED CAM, AIR FEED	152	
-	1	1	1	2119798-2	DETENT PIN	145	
-	1	1	1	2079383-8	SCR, BHSC, RoHS (M4 X 16)	144	
-	1	1	1	2119655-6	APPLICATOR BASIC ASSEMBLY, EF	141	
-	1	1	1	2119651-1	RAM, ASIAN STYLE, END FEED	140	
-	1	1	1	2119092-2	BOLT, ADJUSTMENT	139	
-	-	-	1	3-23627-7	PIN, RETAIN, GRVD, 3/16 X .854	137	
-	-	REF	-	SEE NOTE 4	MEMORY CHIP, PROGRAMMED	135	
-	-	1	-	1633743-1	SERVO FEED LATCH ASM	133	
-	1	1	1	455888-5	SPACER, CRIMPER	82	
-	1	1	1	2119791-9	DEPRESSOR, WIRE	73	
-	1	1	1	2119956-2	DOCUMENTATION PACKAGE	71	
-	2	2	2	2-18032-2	SCR, SET, FLT POINT M3 X 10.0	70	
-	1	-	1	2119740-1	TAG, IDENTIFICATION	67	
-	2	2	2	2168078-1	SCREW, DRIVE, RH, RoHS, 2 x .188	66	
-	1	1	1	1901681-1	HOLDDOWN, TERMINAL	65	
-	2	2	2	2168400-5	SHCS, LOW HEAD, RoHS, M4 X 20	64	
-	1	1	1	2119793-1	LIMITER, ADJUSTMENT BOLT	63	
-	3	3	3	992763-5	SCR, SET, SOC, CONE POINT, M3 x 4.0	62	
-	3	3	3	2168400-4	SHCS, LOW HEAD, RoHS, M4 X 8	57	
-	2	2	2	2168083-9	SCR, SKT HD CAP, RoHS, M4 X 20	56	
-	2	2	2	5018030-2	NUT, HEX, REG, RoHS, M4	55	
-	2	2	2	5018030-1	NUT, HEX, REG, RoHS, M3	54	
-	2	2	2	986965-8	NUT, LOCK, HEX, TORQUE (M4)	53	
-	1	1	1	1-5018030-0	NUT, HEX, REG, RoHS, M3.5	52	
-	-	-	1	2119792-2	PAWL, EF, AIR	51	
-	-	-	1	18023-9	SCR, SKT HD CAP M4 X 6.0	49	
-	1	1	1	2079383-7	SCR, BHSC, RoHS (M8 X 25)	41	
-	1	1	1	2119645-1	DISC, NUMBERED FA WIRE ADJUSTMENT	40	
-	1	1	1	2119957-1	APPLICATOR SHIM PACK	39	
-	1	1	1	1-2119644-2	RAM WASHER, PRECISION	38	
-	7	7	7	1-18028-2	WASHER, FLAT, REG M4	33	
-	2	2	2	2168083-9	SCR, SKT HD CAP, RoHS, M4 X 20	31	
-	2	2	2	1-2168083-0	SCR, SKT HD CAP, RoHS, M4 X 10	29	
-	1	1	1	240639-1	STRIPPER (MACHINING)	27	
-	2	2	2	1320906-1	STUD, THREADED	25	
-	1	1	1	1752371-8	PLATE, STRIP GUIDE	24	
-	1	1	1	240825-7	PLATE, STRIP HOLD DOWN	23	
-	2	2	2	2-22281-3	SPRING, COMPRESSION	22	
-	1	1	1	1752373-4	DRAG	20	
-	2	2	2	1901259-6	GUIDE, LOWER STRIP	18	
-	1	1	1	6-240641-8	SPACER	16	
-	1	1	1	1752360-1	SPACER, HOLD-DOWN	13	
-	1	1	1	240833-1	PLATE, REAR SHEAR	11	
-	-	-	-	-	-	10	
-	1	1	1	690482-5	PLATE, FRONT SHEAR	9	
-	1	1	1	1-1333217-3	ANVIL, EF .090	8	
-	1	1	1	2217206-7	BLADE, SLUG	7	
-	-	-	-	-	-	6	
-	1	1	1	6-240641-8	SPACER	5	
-	1	1	1	238009-1	BLOCK, FL CRIMPER SPACER	4	
-	1	1	1	7-1633961-6	CRIMPER, INSULATION F PREMIUM	3	
-	-	-	-	-	-	2	
-	1	1	1	4-456406-7	CRIMPER, WIRE PREMIUM	1	
-	77	27	25	22	PART NO	DESCRIPTION	ITEM NO

DIMENSIONS:		TOLERANCES UNLESS OTHERWISE SPECIFIED:		DRAWN: G. GROSS 04OCT2013		CHK: G. BAILEY 04OCT2013		NAME: M. CLIFFORD 04OCT2013		TE Connectivity Harrisburg, PA 17105-3608	
mm		0 PLC ±.5 1 PLC ±.5 2 PLC ±.13 3 PLC ±.013 4 PLC ±.0001 ANGLES ±.1		PRODUCT SPEC		APPLICATION SPEC		SIZE: A		CAGE CODE: 00779	
MATERIAL:		FINISH:		WEIGHT:		SCALE: 1:1		SHEET: 3 OF 4		REV: A	
Customer Accessible Production Drawing										Customer Accessible Production Drawing	

LOC		DIST		REVISIONS			
A	66	P	LTM	DESCRIPTION	DATE	DWN	APVD
		-		SEE SHEET 1			

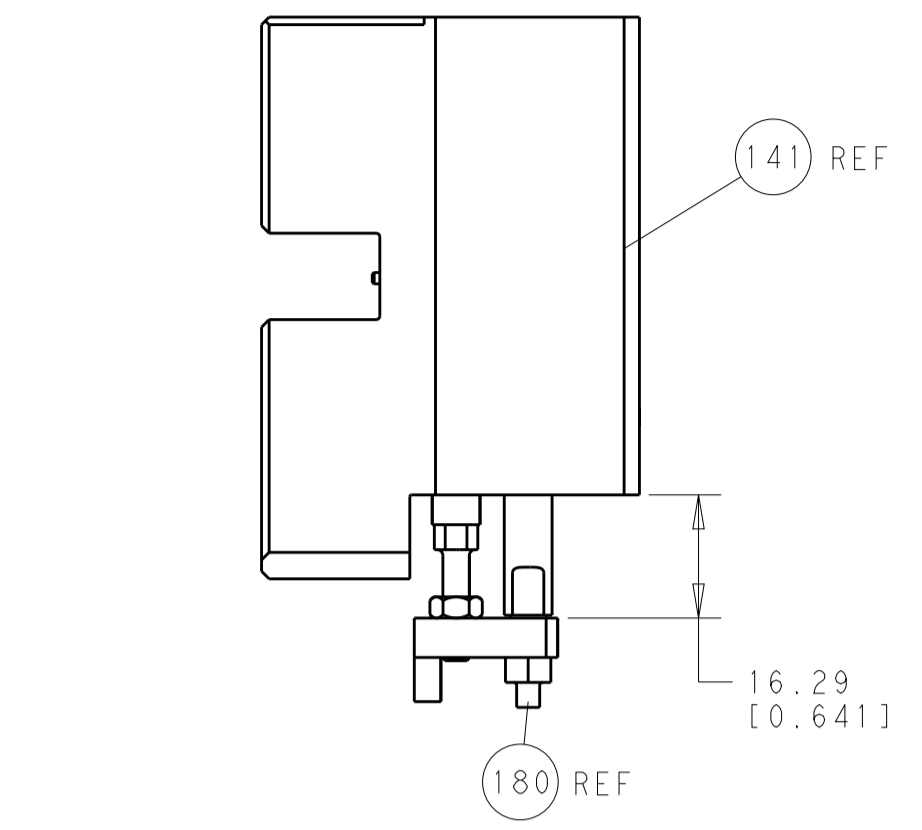

HOLDDOWN SET-UP

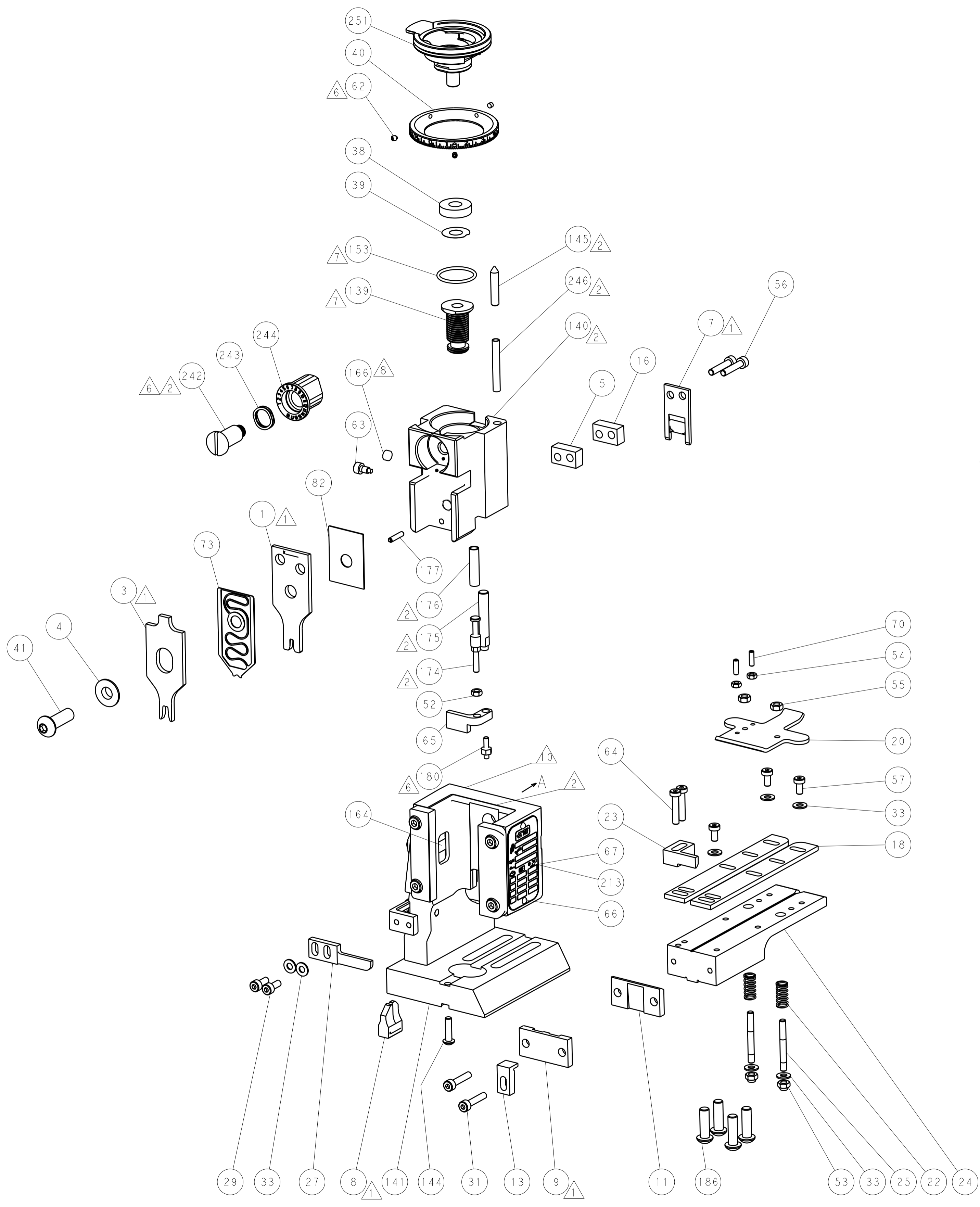

FEED TYPE  
 PNEUMATIC

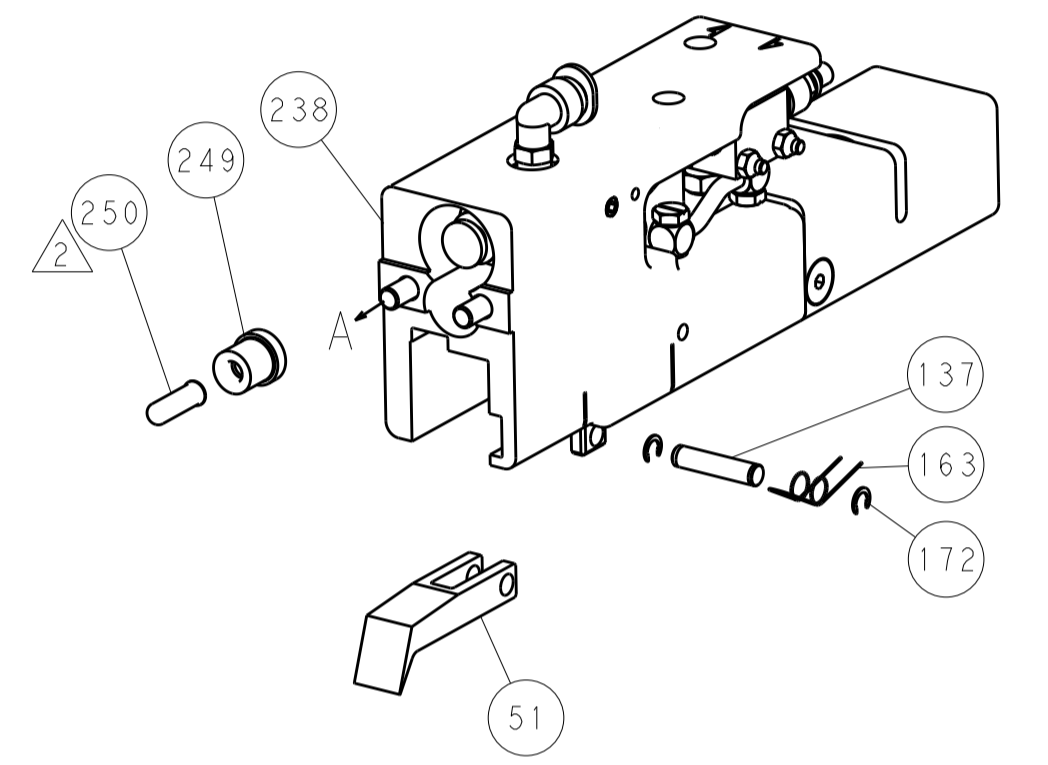

SERVO  
 LATCH PLATE

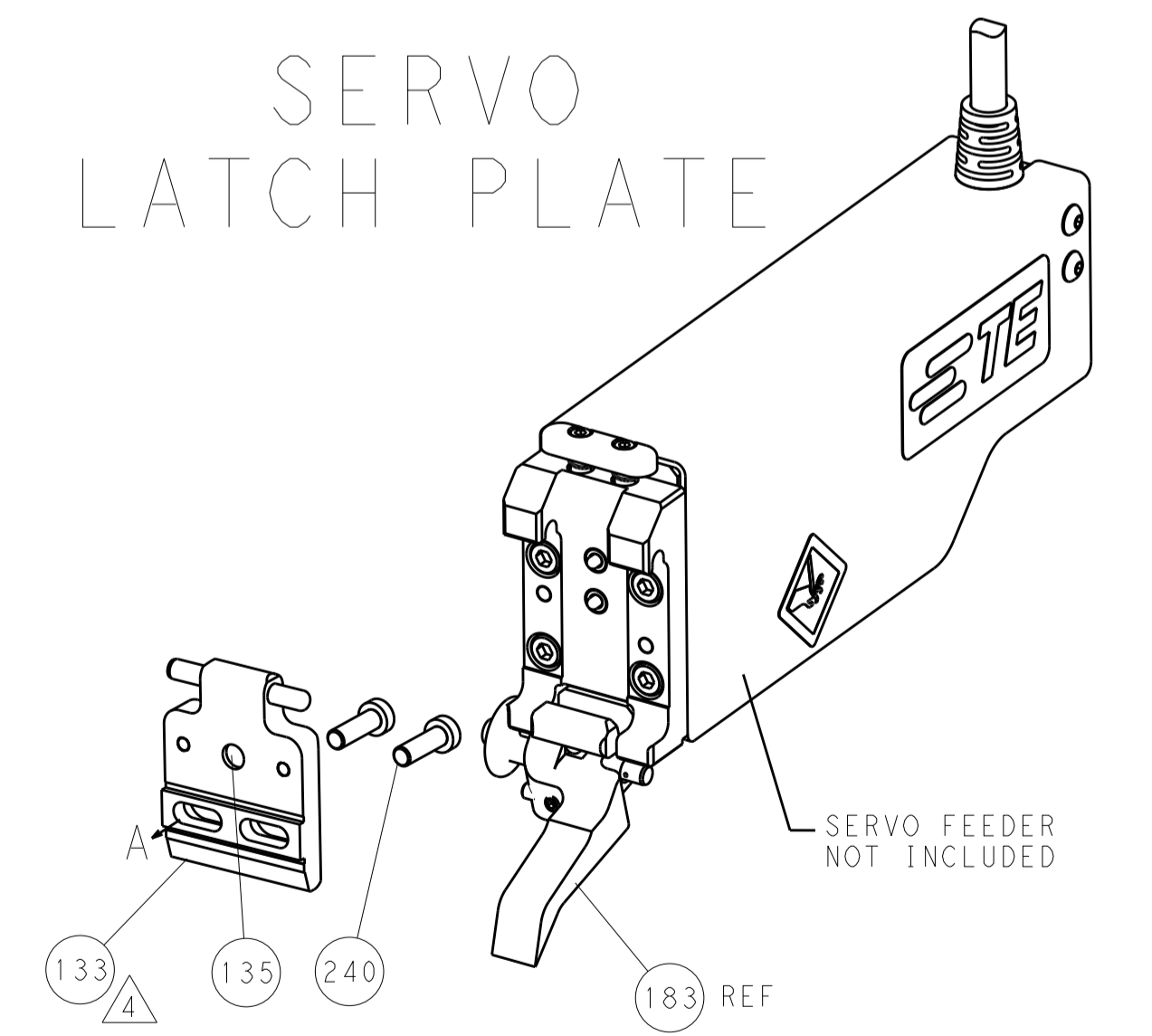

CAM POSITION

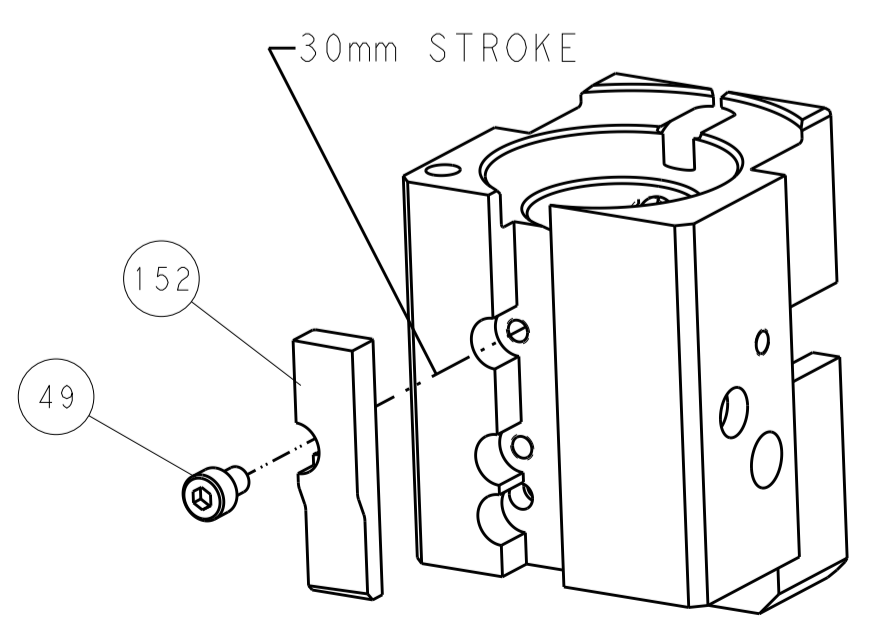

AIR FEED

PACIFIC VERSION  
 Shown on sheets 3 of 4 & 4 of 4  
 (Atlantic version shown on sheets 1 of 4 & 2 of 4)

DIMENSIONS:		TOLERANCES UNLESS OTHERWISE SPECIFIED:		DWN L.GROSS 04OCT2013		STE TE Connectivity	
mm	0 PLC ±0.5	1 PLC ±0.5	2 PLC ±0.13	3 PLC ±0.13	4 PLC ±0.013	5 PLC ±0.001	Harrisburg, PA 17105-3608
	ANGLES ±0.0001			CHK G.BAILEY 04OCT2013	NAME		
MATERIAL:		FINISH:		APVD M.CLEFFORD 04OCT2013	PRODUCT SPEC		
				APPLICATION SPEC		SIZE CAGE CODE DRAWING NO	
				WEIGHT		A1 00779 C=2150377	
				Customer Accessible Production Drawing		RESTRICTED TO	
				SCALE 1:1		SHEET 4 OF 4 REV A	