

E3 Modulevel[®]

with FOUNDATION Fieldbus[™]
Digital Output

FOUNDATION Fieldbus[™] Operating Manual



*Liquid Level
Displacer Transmitter*



Read this Manual Before Installing

This manual provides information on the E3 Modulelevel Electronic Transmitters. It is important that all instructions are read carefully and followed in sequence. Detailed installation, wiring and calibration instructions are included in this manual.

If this equipment is used in a manner not specified by this manufacturer, the protection provided by the equipment may be impaired.

Conventions Used in this Manual

Certain conventions are used in this manual to convey specific types of information. General technical material, support data, and safety information are presented in narrative form. The following styles are used for notes, cautions, and warnings.

Notes

Notes contain information that augments or clarifies an operating step. Notes do not normally contain actions. They follow the procedural steps to which they refer.

Cautions

Cautions alert the technician to special conditions that could injure personnel, damage equipment, or reduce a component's mechanical integrity. Cautions are also used to alert the technician to unsafe practices or the need for special protective equipment or specific materials. In this manual, a caution box indicates a potentially hazardous situation which, if not avoided, may result in minor or moderate injury.

Warnings

Warnings identify potentially dangerous situations or serious hazards. In this manual, a warning indicates an imminently hazardous situation which, if not avoided, could result in serious injury or death.

Safety Messages

Follow all standard industry procedures for servicing electrical and computer equipment when working with or around high voltage. Always shut off the power supply before touching any components.

Electrical components are sensitive to electrostatic discharge. To prevent equipment damage, observe safety procedures when working with electrostatic sensitive components.

WARNING! Explosion hazard. Do not connect or disconnect equipment unless power has been switched off or the area is known to be non-hazardous.

Low Voltage Directive

For use in Installation Category I, Pollution Degree 2. If equipment is used in a manner not specified by manufacturer, protection provided by equipment may be impaired.

Notice of Trademark, Copyright and Limitations

Magnetrol & Magnetrol logotype and Modulelevel are registered trademarks of Magnetrol International, Incorporated.

Copyright © 2009 Magnetrol International.
All rights reserved.

Performance specifications are effective with date of issue and are subject to change without notice. Magnetrol reserves the right to make changes to the product described in this manual at any time without notice. Magnetrol makes no warranty with respect to the accuracy of the information in this manual.

Warranty

All Magnetrol electronic level and flow controls are warranted free of defects in materials or workmanship for one full year from the date of original factory shipment.

If returned within the warranty period; and, upon factory inspection of the control, the cause of the claim is determined to be covered under the warranty; then, Magnetrol will repair or replace the control at no cost to the purchaser (or owner) other than transportation.

Magnetrol shall not be liable for misapplication, labor claims, direct or consequential damage or expense arising from the installation or use of equipment. There are no other warranties expressed or implied, except special written warranties covering some Magnetrol products.

Quality Assurance

The quality assurance system in place at Magnetrol guarantees the highest level of quality throughout the company. Magnetrol is committed to providing full customer satisfaction both in quality products and quality service.

Magnetrol's quality assurance system is registered to ISO 9001 affirming its commitment to known international quality standards providing the strongest assurance of product/service quality available.





E3 Modulelevel Displacer Level Transmitter Installation, Operation and Maintenance Manual

Table of Contents

1.0 FOUNDATION fieldbus™ Overview	
1.1 Description	4
1.2 Benefits	5
1.3 Device Configuration.....	5
1.4 Intrinsic Safety	6
1.5 Link Active Scheduler (LAS).....	6
2.0 QuickStart Installation	
2.1 Getting Started.....	7
2.1.1 Equipment and Tools	7
2.1.2 Configuration Information.....	7
2.2 QuickStart Mounting.....	7
2.2.1 Tank Top.....	7
2.2.2 External Chamber	8
2.3 QuickStart Wiring	8
2.4 QuickStart Configuration	9
3.0 Complete Installation	
3.1 Unpacking	10
3.2 Electrostatic Discharge (ESD) Handing Procedure..	10
3.3 Before You Begin.....	11
3.3.1 Site Preparation	11
3.3.2 Equipment and Tools	11
3.3.3 Operational Considerations.....	11
3.4 Mounting.....	12
3.4.1 Tank Top Installation (E3A & E3B).....	12
3.4.2 External Chamber Installation (E3C, E3D, E3E, E3F)	13
3.5 Wiring	14
3.5.1 General Purpose or Non-Incendive	15
3.5.2 Intrinsically Safe	15
3.5.3 Explosion Proof.....	16
4.0 Reference Information	
4.1 Overview.....	17
4.1.1 Universal Fieldbus Block Parameters	17
4.2 Resource Block.....	18
4.3 Modulelevel Transducer Block	21
4.3.1 Modulelevel Transducer Block Parameters.....	21
4.3.2 Password Parameters.....	21
4.3.3 E3 Modulelevel Configuration Parameters.....	22
4.3.4 Offset Description.....	22
4.4 User-Calibration Parameters.....	22
4.4.1 User Calibration Procedure	22
4.4.2 Factory Parameters	24
4.4.3 Firmware Version	24
4.5 Analog Input Block.....	24
4.5.1 AI Block Parameters	24
4.5.2 Local Display of Analog Input Transducer Block Output	27
4.5.2.1 AI Out Display Screens.....	27
4.6 PID Block.....	28
4.6.1 PID Block Parameters	28
5.0 E3 Modulelevel Menu: Step by Step Procedure	
5.1 Measurement Type: Level Only.....	31
6.0 Diagnostic Parameters	
6.1 Simulation Feature	34
7.0 Documentation	
7.1 Fieldbus Data Sheet for Individual Instrument	35
7.2 Fieldbus Data Sheet for Multiple Devices	36
8.0 Documentation	
8.1 Description	37
8.2 Theory of Operation.....	37
8.2.1 Displacer/Range Spring.....	37
8.2.2 LVDT	37
8.2.3 Interface	38
8.2.4 Density.....	38
8.3 Troubleshooting	38
8.3.1 Troubleshooting System Problems.....	39
8.3.2 Checking the LVDT Winding Resistance.....	40
8.3.3 Device Status Parameter in the Transducer Block.....	41
8.3.4 FF Segment Checklist	43
8.4 Agency Approvals.....	44
8.4.1 FM (Factory Mutual)	44
8.4.2 CSA (Canadian Standards Association)	44
8.4.3 ATEX (European Directive for Explosion Protection)	45
8.4.4 Agency Drawings	46
8.5 Parts.....	47
8.5.1 Transmitter Head Replacement Parts.....	47
8.5.2 Mechanical Replacement Parts	48
8.5.3 Recommended Spare Parts	49
8.6 Specifications	50
8.6.1 Functional	50
8.6.2 Performance – Level	51
8.6.3 Performance – Interface Level & Density.....	51
8.6.4 Physical	52
8.7 Model Numbers.....	54
8.7.1 E3x for Non-Steam Service	54
8.7.2 E3x for Steam Service.....	56
8.8 References	58
Appendix – Transducer Block Parameters	58
FOUNDATION fieldbus Configuration Data Sheet	59

1.0 FOUNDATION Fieldbus™ Overview

1.1 Description

FOUNDATION fieldbus™ is a digital communications system that serially interconnects devices in the field. A Fieldbus system is similar to a Distributed Control System (DCS) with two exceptions:

- Although a FOUNDATION fieldbus™ system can use the same physical wiring as an existing 4–20 mA device, Fieldbus devices are not connected point to point, but rather are multidropped and wired in parallel on a single pair of wires (referred to as a segment).
- FOUNDATION fieldbus™ is a system that allows the user to distribute control across a network. Fieldbus devices are smart and actually maintain control over the system.

Unlike 4–20 mA analog installations in which the two wires carry a single variable (the varying 4–20 mA current), a digital communications scheme such as FOUNDATION fieldbus™ considers the two wires as a network. The network can carry many process variables as well as other information. The E3 Modulelevel transmitter is a FOUNDATION fieldbus™ registered device that communicates with the H1 FOUNDATION fieldbus™ protocol operating at 31.25 kbits/sec. The H1 physical layer is an approved IEC 61158 standard.

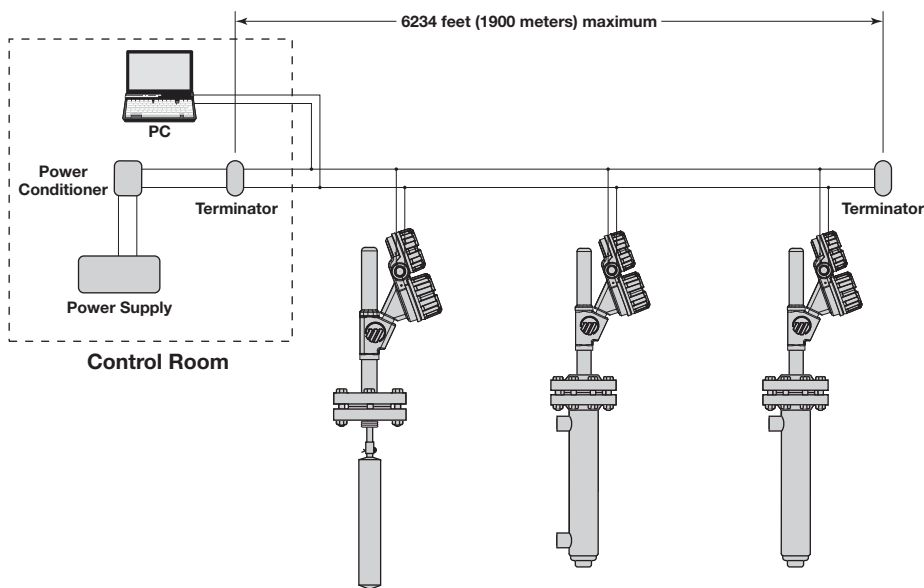

Figure 1
Typical Fieldbus Installation

An IEC61158 shielded twisted pair wire segment can be as long as 6234 feet (1900 meters) without a repeater. Up to 4 repeaters per segment can be used to extend the distance. The maximum number of devices allowed on a Fieldbus segment is 32 although this depends on the current draw of the devices on any given segment. See Figure 1.

Details regarding cable specifications, grounding, termination, and other network information can be found in IEC 61158 or the wiring installation application guide AG-140 at www.fieldbus.org.

1.2 Benefits

The benefits of FOUNDATION fieldbus™ can be found throughout all phases of an installation:

1. **Design/Installation:** Connecting multiple devices to a single pair of wires means less wire and fewer I/O equipment. Initial Engineering costs are also reduced because the Fieldbus Foundation requires interoperability, defined as “the ability to operate multiple devices in the same system, regardless of manufacturer, without a loss of functionality.” All FOUNDATION fieldbus™ devices must be tested for interoperability by the Fieldbus Foundation. Magnetrol E3 Modulelevel FOUNDATION fieldbus™ device registration information can be found at www.fieldbus.org.
2. **Operation:** With control now taking place within the devices in the field, better loop performance and control are the result. A FOUNDATION fieldbus™ system allows for multiple variables to be brought back from each device to the control room for additional trending and reporting.
3. **Maintenance:** The self-diagnostics residing in the smart field devices minimizes the need to send maintenance personnel to the field.

1.3 Device Configuration

Device Descriptions

The function of a FOUNDATION fieldbus™ device is determined by the arrangement of a system of blocks defined by the Fieldbus Foundation. The types of blocks used in a typical User Application are described as follows:

Resource Block describes the characteristics of the FOUNDATION fieldbus™ device such as the device name, manufacturer, and serial number.

Function Blocks are built into the FOUNDATION fieldbus™ devices as needed to provide the desired control system behavior. The input and output parameters of function blocks can be linked over the Fieldbus. There can be numerous function blocks in a single User Application.

Transducer Blocks contain information such as calibration parameters and sensor type. They are used to connect the sensor to the input function blocks.

An important requirement of Fieldbus devices is the interoperability concept mentioned earlier. Device Description (DD) technology is used to achieve this interoperability. The DD provides extended descriptions for each object and provides pertinent information needed by the host system.

DDs are similar to the drivers that your personal computer (PC) uses to operate peripheral devices connected to it. Any Fieldbus host system can operate with a device if it has the proper DD and Common File Format (CFF) for that device.

The most recent DD and CFF files can be found on the FOUNDATION fieldbus™ web site at fieldbus.org.

1.4 Intrinsic Safety

The H1 physical layer supports Intrinsic Safety (IS) applications with bus-powered devices. To accomplish this, an IS barrier or galvanic isolator is placed between the power supply in the safe area and the device in the hazardous area.

H1 also supports the Fieldbus Intrinsically Safe Concept (FISCO) model which allows more field devices in a network. The FISCO model considers the capacitance and inductance of the wiring to be distributed along its entire length. Therefore, the stored energy during a fault will be less and more devices are permitted on a pair of wires. Instead of the conservative entity model, which only allows about 90 mA of current, the FISCO model allows a maximum of 110 mA for Class II C installations and 240 mA for Class II B installations.

FISCO certifying agencies have limited the maximum segment length to 1000 meters because the FISCO model does not rely on standardized ignition curves.

The E3 Modulelevel is available with entity IS, FISCO IS, FNICO non-incendive, or explosion proof approvals.

1.5 Link Active Scheduler (LAS)

The default operating class of the E3 Modulelevel with FOUNDATION fieldbus™ is a basic device. However, it is capable of being a Link Active Scheduler (LAS). The LAS controls all communication on a FOUNDATION fieldbus™ segment. It maintains the “Live List” of all devices on a segment, coordinates both the cyclic and acyclic timing and, at any given time, controls which device publishes data via Compel Data (CD) and Pass Token (PT).

The primary LAS is usually maintained in the host system, but in the event of a failure, all associated control can be transferred to a backup LAS in a field device such as the E3 Modulelevel. The operating class of E3 Modulelevel can be changed from basic to LAS using a FOUNDATION fieldbus configuration tool.

2.0 QuickStart Installation

2.1 Getting Started

2.1.1 Equipment and Tools

No special equipment or tools are required to install E3 Modulelevel. The following items are recommended:

- Wrenches, flange gaskets and flange bolting appropriate for process connection(s)
- Flat-blade screwdriver
- Level
- 1/8" Allen wrench
- Fieldbus compatible power supply with proper termination

2.1.2 Configuration Information

Some key information is needed to configure the E3 Modulelevel transmitter. Complete the following operating parameters table before beginning configuration.

Display	Question	Answer
LvlUnits	What units of measurement will be used?	
Lvl Ofst	What is the desired level reading when the level is at the calibrated zero reference (typically bottom of the displacer)?	
Proc SG	What is the actual SG of the process liquid at operating temperature?	
ProcTemp	What is the actual operating temperature?	

2.2 QuickStart Mounting

NOTE: Confirm the style and process connection size/type of the E3 Modulelevel transmitter. Ensure it matches the requirements of the installation before continuing with the QuickStart installation.

2.2.1 Tank Top

1. If applicable, adjust and trim the adjustable hanger cable assembly to the required length and mount it between the stem and displacer.
2. Using a level, verify that the vessel mounting flange is level in all directions within 3°.

3. Position the head flange gasket on the vessel flange and gently lower the displacer into the vessel. To prevent damage to the stem/spring assembly, avoid tipping the unit or, in any way, putting lateral forces on the stem.
4. Align the flanges and ensure that the gasket is seated properly.
5. Install the flange bolts and nuts and tighten alternating nuts in a star pattern. Flange bolting torque specifications are listed on page 12.

2.2.2 External Chamber

1. Remove the shipping strap and wire assembly which secures the displacer in the chamber during shipment. This assembly must be removed through the bottom connection or drain.
2. Using a level, verify that the vessel mounting flanges are level in all directions within 3°.
3. Align the Modulevel process connections with those on the vessel and attach accordingly, based upon the connection type. Appropriate gaskets and bolting will be required for flanged connections. Install the flange bolts and nuts and tighten alternating nuts in a star pattern. Flange bolting torque specifications are listed on page 12.

2.3 QuickStart Wiring

WARNING: Explosion hazard. Do not connect or disconnect equipment unless power has been switched off or the area is known to be non-hazardous.

NOTE: Ensure that the electrical wiring to the E3 transmitter is complete and in compliance with all regulations and codes.

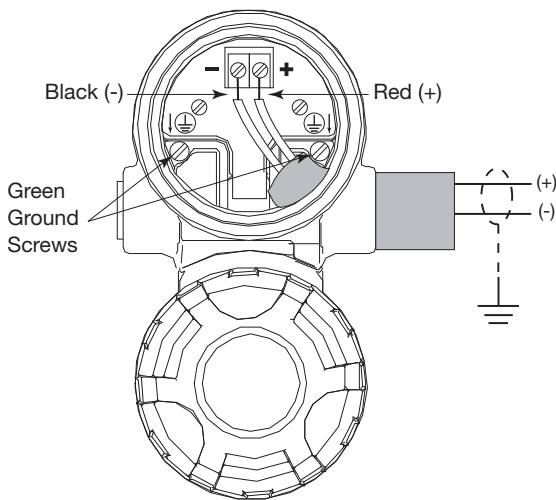

⊕ Protective Conductor Terminal

Figure 2
Integral Transmitter Wiring

1. Remove the cover of the upper wiring compartment of the transmitter.
2. Attach a conduit fitting and mount the conduit plug in the spare opening. Pull the power supply wire through the conduit fitting.
3. Connect an earth ground to the nearest green ground screw. See Figure 2. Use a minimum 18 AWG rated up to 85° C.
4. Connect the positive supply wire to the (+) terminal and the negative supply wire to the (-) terminal. For Explosion Proof Installations, see Wiring, Section 3.5.3.
5. Replace the cover and tighten.

2.4 QuickStart Configuration

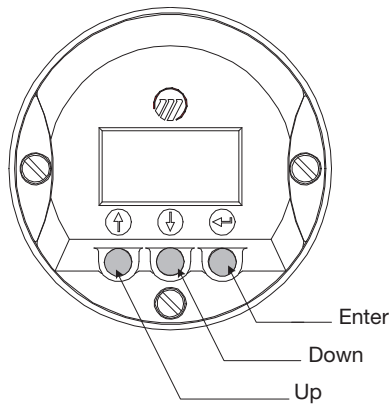

Figure 3
Transmitter Keypad & Display

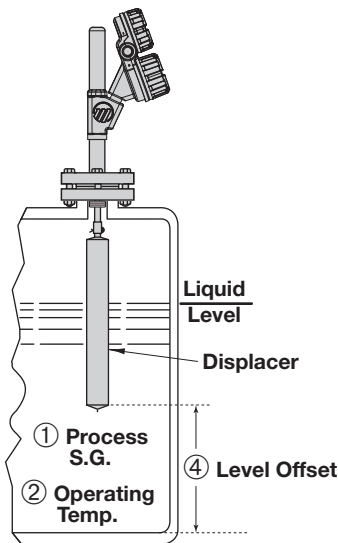

Figure 4
Tank Top Mounted Installation

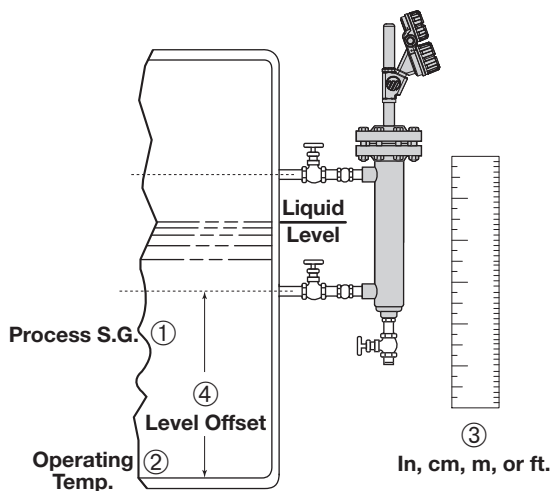

Figure 5
Chamber Type Installation
Side-Side Process Connections

The E3 Modulelevel transmitter comes configured with default values from the factory but can be reconfigured in the shop. The minimum configuration instructions required in the field follow. Use the information from the operating parameters table in Section 2.1.2 before beginning configuration.

1. Power up the transmitter.

The display changes every 5 seconds to show one of three values: Status, PV-Lvl (or PV-Ifc or PV-SG) and AI Out.

2. Remove the cover of the lower electronic compartment.
3. Use the \uparrow and \downarrow keys to move from one step of the configuration program to the next step, see Figure 3.
4. Press \leftarrow key. The last character in the first line of the display changes to an exclamation point (!).

LvlUnits!
xxx
5. Use the \uparrow and \downarrow keys to increase or decrease the value in the display or to scroll through the choices.
6. Press \leftarrow key to accept a value and move to the next step of the configuration program (the default password is 1).
7. After entering the last value, allow 10 seconds before removing power from the transmitter.

The following two configuration entries are the minimum required for configuration (the default password is 1 from the LCD/keypad).

- | | | | | |
|----------|--|----------|-------|--|
| ① | <table border="1" data-bbox="776 1234 922 1291"><tr><td>Proc SG</td></tr><tr><td>(xxx)</td></tr></table> | Proc SG | (xxx) | Enter the actual specific gravity of the process liquid at operating temperature (N/A for Interface or Density). |
| Proc SG | | | | |
| (xxx) | | | | |
| ② | <table border="1" data-bbox="776 1327 922 1383"><tr><td>ProcTemp</td></tr><tr><td>xxx</td></tr></table> | ProcTemp | xxx | Enter the actual operating temperature of the process |
| ProcTemp | | | | |
| xxx | | | | |

The following two parameters must be entered if the default values are not satisfactory.

- | | | | | |
|----------|---|----------|----------|---|
| ③ | <table border="1" data-bbox="776 1520 922 1577"><tr><td>LvlUnit</td></tr><tr><td>(select)</td></tr></table> | LvlUnit | (select) | Select the desired level units (inches, cm, m, feet). |
| LvlUnit | | | | |
| (select) | | | | |
| ④ | <table border="1" data-bbox="776 1612 922 1669"><tr><td>Lvl Ofst</td></tr><tr><td>(xxx)</td></tr></table> | Lvl Ofst | (xxx) | Enter the desired level reading when level is at the calibrated zero reference (typically bottom of the displacer). |
| Lvl Ofst | | | | |
| (xxx) | | | | |

3.0 Complete Installation

3.1 Unpacking

Unpack the instrument carefully. Take care not to bend the displacer stem or enclosing tube. Ensure all components have been removed from the packing material. Check all the contents against the packing slip and report any discrepancies to the factory.

Before proceeding with the installation, do the following:

- Inspect all components for damage. Report any damage to the carrier within 24 hours.
- On chambered units, remove the shipping strap and wire assembly holding the displacer in place. This assembly must be removed through the bottom chamber connection before start-up.

Caution: If reshipping to another location, the displacer must again be secured using the same strap and wire assembly.

- Check that the model number on the nameplate matches the packing slip and purchase order.
- Record the model and serial numbers for future reference when ordering parts.

Model Number

Serial Number

3.2 Electrostatic Discharge (ESD) Handling Procedure

Magnetrol's electronic instruments are manufactured to the highest quality standards. These instruments use electronic components which may be damaged by static electricity present in most work environments.

The following steps are recommended to reduce the risk of component failure due to electrostatic discharge.

- Ship and store circuit boards in anti-static bags. If an anti-static bag is not available, wrap the board in aluminum foil. Do not place boards on foam packing materials.
- Use a grounding wrist strap when installing and removing circuit boards. A grounded workstation is recommended.
- Handle circuit boards only by the edges. Do not touch components or connector pins.
- Ensure that all electrical connections are completely made and that none are partial or floating. Ground all equipment to a good, earth ground.

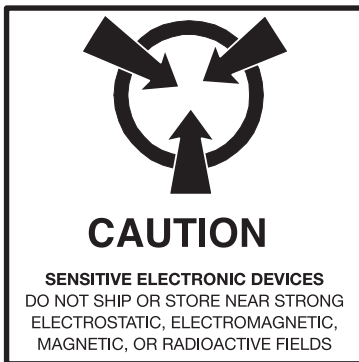

3.3 Before You Begin

3.3.1 Site Preparation

Each E3 Modulelevel transmitter is built to match the physical specifications of the required installation. Ensure that the process connection(s) on the vessel matches the Modulelevel's process connection(s).

See *Mounting, Section 3.4*.

Ensure that the wiring between the power supply and Modulelevel transmitter are complete and correct for the type of installation.

When installing the Modulelevel transmitter in a general purpose or hazardous area, local, state and federal regulations and guidelines must be observed.

See *Wiring, Section 3.5.3*.

3.3.2 Equipment and Tools

No special equipment or tools are required to install the Electronic Modulelevel. The following items are recommended:

- Wrenches, flange gaskets and flange bolting appropriate for process connection(s)
- Flat-blade screwdriver
- Level
- 1/8" Allen wrench
- Fieldbus compatible power supply with proper termination

3.3.3 Operational Considerations

The Modulelevel transmitter should be located for easy access for service, configuration, and monitoring. There should be sufficient headroom to allow installation and removal of the transmitter head and, in cases of tank top configuration, the displacer. Special precautions should be made to prevent exposure to corrosive atmosphere, excessive vibration, shock, or physical damage.

The operating temperature range for the transmitter electronics is -40° to +176° F (-40° to +80° C). The operating temperature range for the digital display is -5° to +160° F (-20° to +70° C).

Caution: Operation of all buoyancy type level devices should be done in such a way as to minimize the action of dynamic forces on the float or displacer sensing element. Good practice for reducing the likelihood of damage to the control is to equalize pressure across the device very slowly.

3.4 Mounting

The E3 Modulelevel transmitter can be mounted to a tank using a variety of configurations and process connections. Generally, either a threaded, welded or flanged connection is used with an external cage. A flanged connection is always used on a tank top model. For information about the sizes and types of connections available, see *Model Numbers, Section 8.7*.

Ensure all mounting connections are in place on the tank and properly sized for the specific unit being installed. Compare the model on the nameplate with the product information to ensure the Modulelevel transmitter is correct for the intended installation.

If the Modulelevel must be insulated, DO NOT insulate the transmitter head, e-tube or finned extensions.

Torque Specifications for Enclosing Tubes and Flange Bolting

Model	Flange Bolting	E-tube
E3A, E3B	n/a	200 – 225 ft-lbs
E3C, E3D, E3E, E3F – 150#	110–120 ft-lbs	
E3C, E3D, E3E, E3F – 300#	180–200 ft-lbs	
E3C, E3D, E3E, E3F – 600#	180–200 ft-lbs	
E3C, E3D, E3E, E3F – 900#	370–400 ft-lbs	
E3C, E3D, E3E, E3F – 1500#	630–690 ft-lbs	
E3C, E3D, E3E, E3F – 2500#	675–725 ft-lbs	

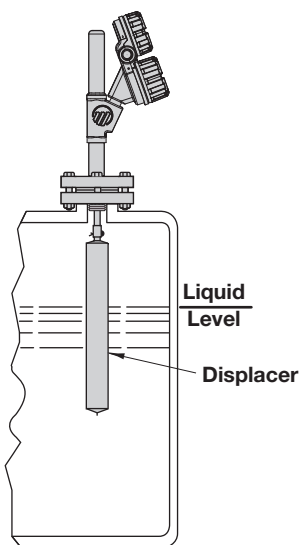

Figure 6
Tank Top Mounted
Installation

3.4.1 Tank Top Installation (E3A & E3B)

Figure 6 illustrates a typical tank top installation.

Before installing, ensure that:

- There is adequate headroom for the installation of the Modulelevel head and displacer and that it has unobstructed entry into the vessel.
- Using a level, the mounting flange is level within 3° in all directions.
- If the adjustable hanger assembly (P/N 32-3110-001) is used, it is cut to the required length and attached to the displacer stem.

NOTE: The adjustable hanger assembly is used when the top of the displacer and, therefore, the top of the measurement range must be positioned in the vessel more than 9.31" below the mounting flange. The standard hanger cable length is 8 feet. Consult factory for longer cable.

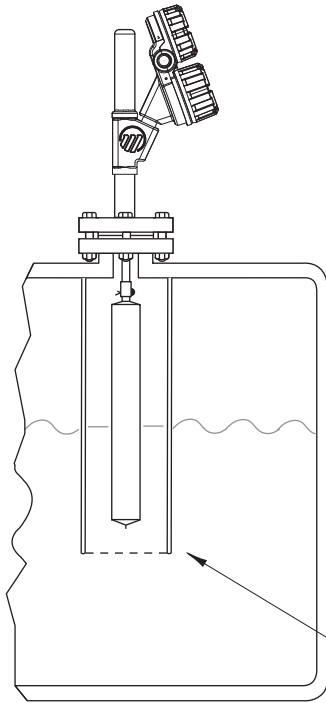

Figure 7
Tank Top Mounted
with Stilling Well

Use stilling well in case of turbulent medium

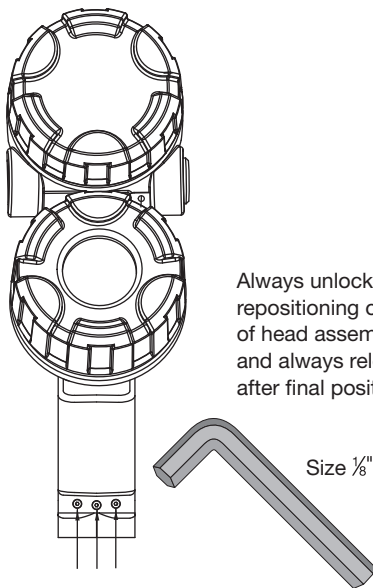

Figure 8
Transmitter Head
Lock Screws

Always unlock for repositioning or removal of head assembly and always relock, after final positioning

Size 1/8"

- A stilling well is installed for applications where continuous agitation is present. The stilling well must be vertically level so as not to restrict displacer movement. See Figure 7 for a typical stilling well installation.
- The process temperature, pressure and specific gravity are within the unit's specifications for installation. See *Specifications, Section 8.6*.

To install:

1. Position the head flange gasket on the vessel flange and gently lower the displacer into the vessel. To prevent damage to the stem/spring assembly, avoid tipping the unit or, in any way, putting lateral forces on the stem.
2. Align the flanges and ensure that the gasket is seated properly.
3. Install the flange bolts and nuts and tighten alternating nuts in a star pattern. Flange bolting torque specifications are listed on page 12.

Caution: All Modulevels are shipped from the factory with the enclosing tube tightened and the transmitter head set screws locked to the enclosing tube. Failure to loosen the set screws prior to repositioning the supply and output connections may cause the enclosing tube to loosen, resulting in the possible leakage of the process liquid or vapor.

4. Loosen the transmitter head lock screws (socket type) and position conduit outlet in the desired direction. See Figure 8.
5. Retighten lock screws.

NOTE: Since the transmitter head is rotatable through 360°, it is important to make certain that the controller locking screws are tight before making electrical connections.

3.4.2 External Chamber Installation (E3C, E3D, E3E & E3F)

The chamber type Modulevel is mounted on the side of the vessel with either a side/side or side/bottom connection, as furnished. Figure 9 on page 14 illustrates a typical chamber type installation.

Before installing, ensure that:

- There is adequate room for installation of the Modulevel.
- Using a level, the vessel mounting connections are level within 3° in all directions.
- The process temperature, pressure and specific gravity are within the unit's specifications for installation. See *Specifications, Section 8.6*.
- If not already done, remove the shipping strap and wire assembly holding the displacer in place in the chamber. This assembly must be removed through the bottom chamber connection or drain before start-up.

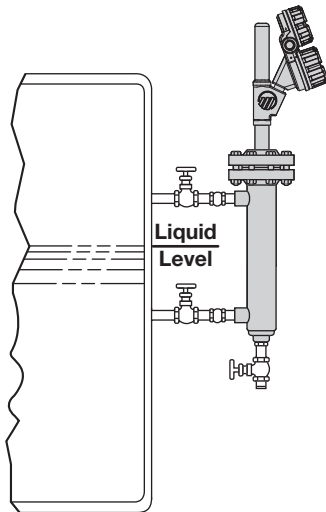

Figure 9
Chamber Type Installation
Side-Side Process Connections

To install:

1. Align the Modulelevel process connections with those on the vessel and attach accordingly, based upon the connection type. Appropriate gaskets and bolting will be required for flanged connections. Install the flange bolts and nuts and tighten alternating nuts in a star pattern. Flange bolting torque specifications are listed on page 12.

NOTE: It is recommended that shut-off valves be installed in each equalizing line to the chamber, along with a drain valve (refer to Figure 8). Equalizing lines should be sized at least as large as the connections provided at the chamber.

2. Make sure that the chamber is vertically level within 3° in each direction to ensure frictionless operation of the internal displacer.

Caution: All Modulelevels are shipped from the factory with the enclosing tube tightened and the transmitter head set screws locked to the enclosing tube. Failure to loosen the set screws prior to repositioning the supply and output connections may cause the enclosing tube to loosen, resulting in the possible leakage of the process liquid or vapor.

3. Loosen the transmitter head lock screws (socket type) and position conduit outlet in the desired direction. See Figure 8.
4. Retighten lock screws.

NOTE: Since the transmitter head is rotatable through 360°, it is important to make certain that the controller locking screws are tight before making electrical connections.

3.5 Wiring

Caution: FOUNDATION fieldbus E3 Modulelevel transmitter operates at voltages of 9–32 VDC. Higher voltage will damage the transmitter.

Wiring between the power supply and the E3 Modulelevel transmitter should be made using minimum of 18 AWG shielded twisted pair instrument cable. Wiring must be suitable for temperatures up to at least +85° C. Within the transmitter enclosure, connections are made to the terminal strip and the ground connections. When installing a remote mount E3 transmitter, refer to Figures 12 & 13 for wiring connections.

WARNING! Explosion hazard. Do not disconnect equipment unless power has been switched off or the area is known to be non-hazardous.

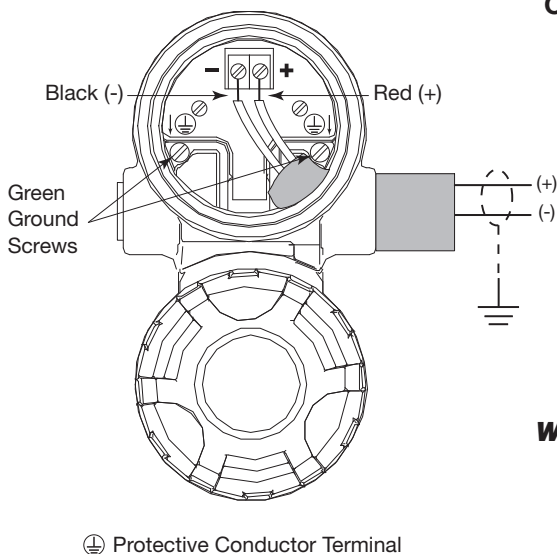

⊕ Protective Conductor Terminal

Figure 10
Wiring Diagram

3.5.1 General Purpose or Non-Incendive (CI I, Div. 2)

A general purpose installation does not have flammable media present. Areas rated non-incendive (CI I, Div. 2) have flammable media present only under abnormal conditions. No special electrical connections are required so standard installation methods may be followed.

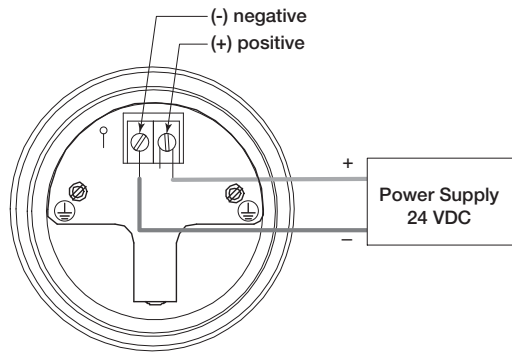

⊕ Protective Conductor Terminal

Figure 11
G.P./I.S./Explosion Proof Model

To install General Purpose or Non-Incendive wiring:

1. Remove the cover to the wiring compartment of the transmitter. Install the conduit plug in the unused opening. Use PTFE tape/sealant to ensure a liquid-tight connection.
2. Install a conduit fitting and pull the supply wires.
3. Connect shield to an earth ground at power supply.
4. Connect an earth ground wire to the nearest green ground screw. Use a minimum 18 AWG rated up to 85° C.
5. Connect the positive supply wire to the (+) terminal and the negative supply wire to the (-) terminal.
6. Replace the cover to the wiring compartment of the transmitter.

To install Remote Mount wiring:

1. Install conduit from the remote mounted head to the integral conduit connection of the E3 transmitter (refer to local plant or facility procedures).
2. Remove the cover of the remote transmitter, terminal board housing and of the integral terminal board housing.
3. Connect one end of the six conductor cable (P/N 037-3226-xxx or 037-3227-xxx) to the integral terminal block and the other end to the terminal block within the remote terminal board housing. Be sure to match the six discrete numbered wires with the numbers on each terminal block. See Figures 12 & 13.
4. Connect shield to an earth ground at the power supply.
5. Connect an earth ground wire to the nearest green ground screw per local electrical code (not shown in illustration).
6. Connect the positive supply wire to the (+) terminal and the negative supply wire to the (-) terminal.
7. Replace the covers to the wiring compartment of the transmitter and to both terminal board housings. Ensure that all covers are completely tightened down before applying power.

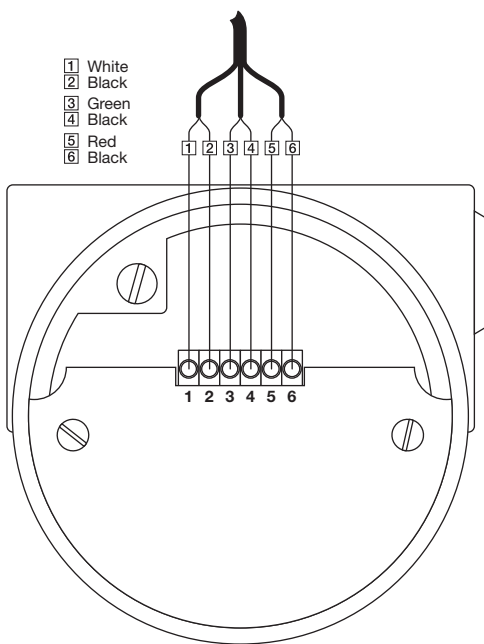

Figure 12
Integral & Remote Terminal Boards

3.5.2 Intrinsically Safe

An intrinsically safe (IS) installation potentially has flammable media present. An approved IS barrier must be installed in the non-hazardous (safe) area. Consult factory for agency drawing.

To install Intrinsically Safe wiring:

1. Make sure the IS barrier is properly installed in the safe area (refer to local plant or facility procedures). Complete the wiring from the barrier to the E3 transmitter.
2. After IS barrier installation, follow General Purpose and Non-incendive wiring procedure on page 15.

3.5.3 Explosion Proof

Explosion Proof (XP) is a method of designing equipment for installation in hazardous areas. A hazardous location is an area in which flammable gases or vapors are, or may be, present in the air in quantities sufficient to produce explosive or ignitable mixtures. The wiring for the transmitter must be contained in Explosion Proof conduit extending into the safe area.

To install Explosion Proof wiring – Integral mount:

Due to the specialized design of the Integral E3 transmitter, no Explosion Proof conduit fitting (EY seal) is required within 18" of the transmitter. An Explosion Proof conduit fitting (EY seal) is required between the hazardous and safe areas. See Agency Approvals, Section 8.4.

1. Install Explosion Proof conduit from the safe area to the conduit connection of the E3 transmitter (refer to local plant or facility procedures).
2. Remove the cover to the wiring compartment of the transmitter.
3. Connect shield to an earth ground at the power supply.
4. Connect an Earth ground wire to the nearest green ground screw per local electrical code. Use a minimum 18 AWG rated up to 85° C.
5. Connect the positive supply wire to the (+) terminal and the negative supply wire to the (-) terminal.
6. Replace the cover to the wiring compartment of the transmitter before applying power.

Caution: Instrument and conduit junction box covers must be in place and tightly sealed at all times during operation.

To install Explosion Proof wiring – Remote mount:

1. Install Explosion Proof conduit from the remote mounted E3 transmitter head to the integrally mounted terminal housing at the LVDT. An Explosion Proof conduit fitting (EY seal) is required within 18" of the remote mounted transmitter head wiring housing (see figure 13). Follow steps 2 through 7 of Remote Mount wiring procedure on page 15.

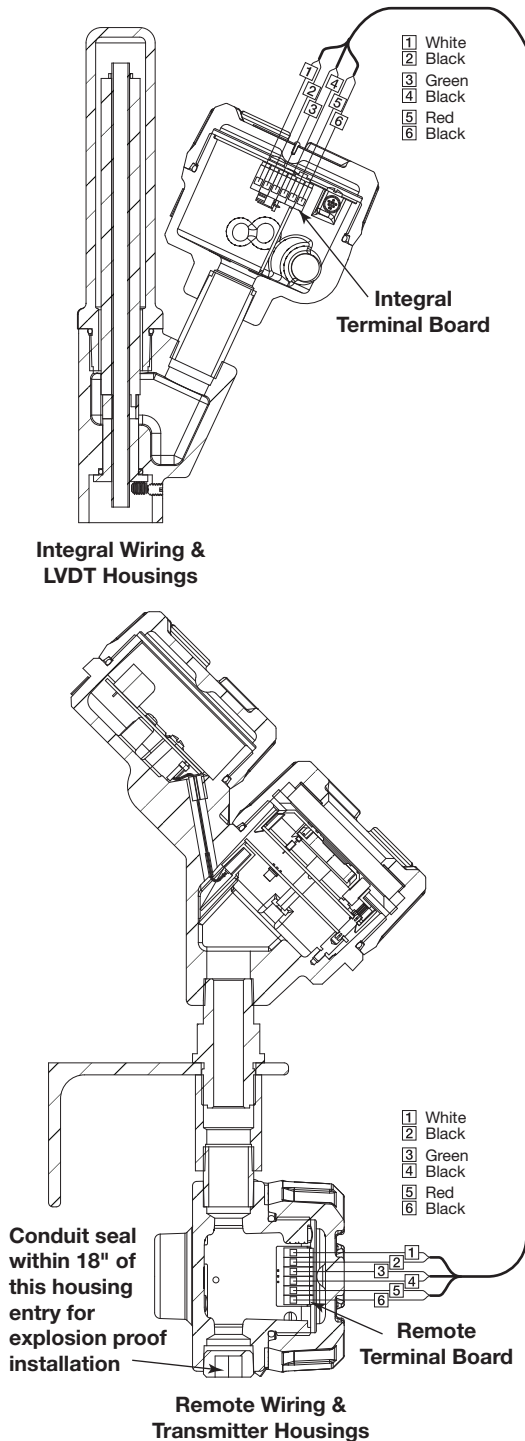

Figure 13

Remote Mount Wiring Connections

4.0 Function Blocks

4.1 Overview

The E3 Modulelevel Liquid Level Displacer Transmitter operates on the Archimedes principle of buoyancy force. Refer to Bulletin 48-635 for more detailed information on the Modulelevel transmitter.

The E3 Modulelevel is a liquid level transmitter with four FOUNDATION fieldbus™ Blocks (one Resource Block, one Transducer Block, one Analog Input Function block, and one PID Function block). The idea of Function Blocks, which a user can customize for a particular application, is a key concept of Fieldbus topology. Function Blocks consist of an algorithm, inputs and outputs, and a user-defined name.

The TRANSDUCER block output is available to the network through the ANALOG INPUT block.

- The ANALOG INPUT block (AI) takes the TRANSDUCER block level or density value and makes it available as an analog value to other function blocks. The AI block has scaling conversion, filtering, and alarm functions.

4.1.1 Universal Fieldbus Block Parameters

The following are general descriptions of the parameters common to all blocks. Additional information for a given parameter is described later in that specific block section.

ST_REV (static data revision): a read only parameter that gives the revision level of the static data associated with the block. This parameter will be incremented each time a static parameter attribute value is written and is a vehicle for tracking changes in static parameter attributes.

TAG_DESC (tag descriptor): a user assigned parameter that describes the intended application of any given block.

STRATEGY: a user assigned parameter that identifies groupings of blocks associated with a given network connection or control scheme.

ALERT_KEY: a user assigned parameter which may be used in sorting alarms or events generated by a block.

MODE_BLK: a structured parameter composed of the actual mode, the target mode, the permitted mode(s), and the normal mode of operation of a block.

- The actual mode is set by the block during its execution to reflect the mode used during execution.
- The target mode may be set and monitored through the mode parameter.

-
- The permitted modes are listed for each block.
 - The block must be in an automatic mode for normal operation.

NOTE: The `MODE_BLK` target parameter must be OOS (out of service) to change configuration and calibration parameters in that function block (when in OOS, the normal algorithm is no longer executed and any outstanding alarms are cleared).

All blocks must be in an operating mode for the device to operate. This requires the Resource Block to be in “AUTO” and the Transducer Block to be in “AUTO” before the Function Blocks can be placed in a mode other than OOS (out of service).

BLOCK_ERR: a parameter that reflects the error status of hardware or software components associated with, and directly affecting, the correct operation of a block.

NOTE: A `BLOCK_ERR` of “Simulation” in the Resource Block does not mean simulation is active—it merely indicates that the simulation enabling hardware jumper is installed.

4.2 Resource Block

The `RESOURCE` block contains data specific to the E3 Modulelevel transmitter, along with some information about the firmware.

NOTE: The Resource Block has no control function.

MODE_BLK: Must be in AUTO in order for the remaining blocks in the transmitter to operate.

NOTE: A Resource Block in “out of service” will stop all function block execution in the transmitter.

RS_STATE (Resource State): identifies the state of the `RESOURCE` block state machine. Under normal operating conditions, it should be “On-Line.”

DD_RESOURCE: a string identifying the tag of the resource that contains the Device Description for this device.

MANUFAC_ID: contains Magnetrol International’s FOUNDATION fieldbus™ manufacturer’s ID number, which is 0x000156.

DEV_TYPE: the model number of the E3 Modulelevel transmitter (0x0003). It is used by interface devices to locate the Device Descriptor (DD) file for this product.

DEV_REV: contains the firmware revision of the E3 Modulelevel transmitter. It is used by interface devices to correctly select the associated DD.

DD_REV: contains the revision of the DD associated with the version of firmware in the E3 Modulelevel transmitter. It is used by interface devices to correctly select the associated DD.

RESTART: Default and Processor selections are available. Default will reset the Model E3 to the default block configuration.

NOTE: RESTART DEFAULT will not reset parameters to their default values in the custom Transducer Block.

FEATURES: a list of the features available in the transmitter. The Model E3 features include Reports, and Software Write Locking.

FEATURES_SEL: allows the user to turn Features on or off.

CYCLE_TYPE: identifies the block execution methods that are available.

CYCLE_SEL: allows the user to select the block execution method.

MIN_CYCLE_T: the time duration of the shortest cycle interval. It puts a lower limit on the scheduling of the resource.

NV_CYCLE_T: the minimum time interval between copies of non-volatile (NV) parameters to NV memory. NV memory is only updated if there has been a significant change in the dynamic value and the last value saved will be available for the restart procedure. A value of "0" means it will never be automatically copied. Entries made by human interface devices to NV parameters are copied to non-volatile memory at the time of entry.

NOTE: After completing a large copy, allow several minutes before removing power from the E3 Modulelevel transmitter to ensure that all data has been saved.

FREE_SPACE: shows the amount of available memory for further configuration. The value is zero percent in a pre-configured device.

FREE_TIME: the amount of the block processing time that is free to process additional blocks.

SHED_RCAS: the time duration at which to give up computer writes to function block RCas locations. Shed from RCas will never happen when SHED_RCAS = 0.

SHED_ROUT: the time duration at which to give up computer writes to function block ROut locations. Shed from ROut will never happen when SHED_ROUT = 0.

FAULT_STATE, SET_FSTATE, CLR_FSTATE: these only apply to output function blocks. (The E3 Modulelevel has no output function blocks).

MAX_NOTIFY: the maximum number of alert reports that the transmitter can send without getting a confirmation.

The user can set the number low, to control alert flooding, by adjusting the LIM_NOTIFY parameter value.

LIM_NOTIFY: the maximum numbers of unconfirmed alert notify messages allowed. No alerts are reported if set to zero.

CONFIRM_TIME: the time that the transmitter will wait for confirmation of receipt of a report before trying again. Retry will not occur if CONFIRM_TIME = 0.

WRITE_LOCK: When set to LOCKED, will prevent any external change to the static or non-volatile data base in the Function Block Application of the transmitter. Block connections and calculation results will proceed normally, but the configuration will be locked.

UPDATE_EVT (Update Event): is an alert generated by a write to the static data in the block.

BLOCK_ALM (Block Alarm): is used for configuration, hardware, connection, or system problems in the block. The cause of any specific alert is entered in the subcode field. The first alert to become active will set the Active status in the Status attribute. As soon as the Unreported status is cleared by the alert reporting task, another block alert may be reported without clearing the Active status, if the subcode has changed.

ALARM_SUM (Alarm Summary): contains the current alert status, the unacknowledged states, the unreported states, and the disabled states of the alarms associated with the block.

ACK_OPTION (Acknowledge Option): selects whether alarms associated with the block will be automatically acknowledged.

WRITE_PRI (Write Priority): the priority of the alarm generated by clearing the write lock.

WRITE_ALM (Write Alarm): the alert generated if the write lock parameter is cleared.

ITK_VER (ITK Version): contains the version of the Interoperability Test Kit (ITK) used by the Fieldbus Foundation during their interoperability testing.

4.3 Modulelevel Transducer Block

The Modulelevel TRANSDUCER block is a custom block containing parameters that support the E3 Modulelevel level transmitter. It contains the model attributes, diagnostics, and calibration data, and outputs a measured value with status information.

The TRANSDUCER block parameters are grouped in a useful configuration. There are both read-only parameters and read-write parameters within the TRANSDUCER block.

- The read-only parameters report the block status and operation modes.
- The read-write parameters affect the function block basic operation, level transmitter operation, and calibration.

The Transducer Block will automatically be changed to “Out of Service” when the local interface (keypad) is used to change a parameter online.

4.3.1 Modulelevel Transducer Block Parameters

The first six parameters in the Modulelevel TRANSDUCER block are the universal parameters discussed in section 4.1.1. The universal parameters are followed by these additional required parameters:

UPDATE_EVT (Update Event): an alert generated by a write to the static data in the TRANSDUCER block.

Another important parameter found later in the TRANSDUCER block list is **DEVICE_STATUS**, which displays the status of the device. If more than one message exists, then the messages are displayed in priority order. Refer to Section 8.3.3, Status Messages.

If **DEVICE_STATUS** indicates a problem, refer to Section 8.3, Troubleshooting.

For a complete list of Transducer Block Parameters, refer to table in the Appendix.

4.3.2 Password Parameters

To change a parameter at the local user interface, a value matching the user password must be entered (Default=1). If the user password is entered, the instrument is in the user mode. After 5 minutes with no keypad activity, the entered password expires.

Factory password is for use by trained factory personnel only.

From the network, the instrument always behaves as if it is in the user mode by default. In other words, it is not necessary to enter the user password in order to write parameters from the network.

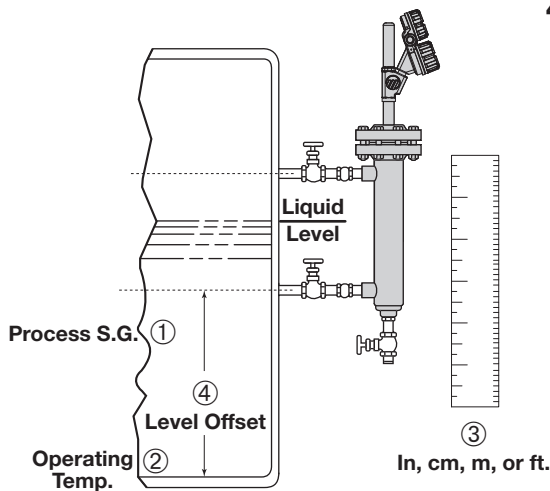

Figure 14
Chamber Type Installation
Side-Side Process Connections

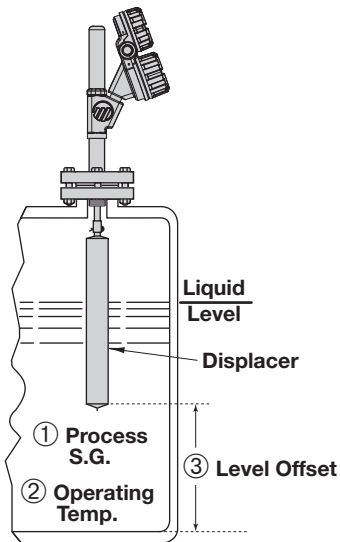

Figure 15
Top Mount Installation

4.3.3 E3 Module Configuration Parameters

The following parameters within the Module Transducer Block are required to configure each E3 Module level.

LEVEL_UNITS: Select the units in which level parameters are displayed (cm, in, feet, meters). (④ in figure 14)

PROCESS_SG: Enter the specific gravity of the process liquid at operating conditions. (① in figures 14 & 15)

PROCESS_TEMPERATURE: Enter the process operating temperature. (② in figures 14 & 15)

LEVEL_OFFSET: Enter the desired level output at the zero reference (bottom of displacer or centerline of bottom-side process connection). (③ in figures 14 & 15)

4.3.4 Offset Description

The parameter referred to as LEVEL_OFFSET in the Transducer Block is the desired level reading when the liquid is at the zero reference point of the E3 Module level.

On the top mounted models E3A and E3B, the zero reference is the bottom of the displacer (not including the hook).

On a side-bottom mounted models E3C and E3D, it is the length of the level range below the centerline of the upper-side process connection.

On side-side mounted models E3E and E3F, the zero reference is the centerline of the bottom-side process connection. Unit is shipped from factory with Level Offset = 0.

Example: Application of an external cage model E3E with a 48" level range is mounted with the centerline of the bottom-side process connection 12" from the bottom of the vessel. 0% point shall be at the bottom of the vessel and 100% at the length of the level range above the bottom of the vessel. Level Offset = 12" must be entered into the E3 menu. See Figure 14.

4.4 User-Calibration Parameters

4.4.1 User Calibration Procedure

One of the main advantages of the E3 Module transmitter is that the device does not need to be calibrated in the field. Every E3 Module transmitter is shipped from the factory precisely calibrated, requiring only configuration by the user in the field.

On the other hand, part of the advantage of FOUNDATION fieldbus™ is to provide the ability to monitor changes and adjustments to a transmitter. For minor calibration adjustments to the measured value, trim parameters are available.

Should the E3 require replacement of any parts in the field, a user calibration must be performed after changing out any of the following original parts: Bezel assembly, LVDT assembly, range spring, stem assembly, or displacer. The following procedure should be followed when performing a user calibration in the field.

1. Move liquid level on displacer to desired low level point.
2. Using the keypad and LCD display, scroll down to DispFact
3. Press \leftarrow to access data entry mode, then \downarrow until “Yes” is displayed and \leftarrow again. The factory menu is now accessible.
4. Scroll down to CalSelct.
5. Press \leftarrow , then \downarrow until “User” is displayed and \leftarrow again.
6. Scroll to “User Cal Menu” and press \leftarrow .
7. Scroll down to SnrCalLo.
8. Press \leftarrow , then \uparrow and \leftarrow simultaneously and \leftarrow again. The current sensor output has been captured for the low level point.
9. Scroll down to LvlCalLo. The default value is 0.00. If a different level value is desired at this point, press \leftarrow , use the \uparrow and \downarrow arrows to choose the desired value and press \leftarrow again.
10. Move the liquid level on displacer to the desired high level point.
11. Scroll to SnrCalHi.
12. Press \leftarrow , then \uparrow and \leftarrow simultaneously and \leftarrow again. The current sensor output has been captured for the high level point.
13. Scroll down to LvlCalHi. The default value is the displacer length. If a different level value is desired at this point, press \leftarrow , use the \uparrow and \downarrow keys to choose the desired value and press \leftarrow again.
14. The user calibration is complete.

NOTE: The original factory calibration settings are restored when “FACTORY” is selected for “Calibration_Select” parameter.

It is highly recommended that factory calibration be used for optimum performance.

4.4.2 Factory Parameters

The factory-adjustable calibrated parameters are found in the factory calibration menu.

The following parameters are read-only and are available for troubleshooting and diagnostics.

LVDT %: current sensor output

ADJUSTED_SENSOR_LO: low sensor calibration point which may be adjusted for process SG and/or temperature.

ADJUSTED_SENSOR_HI: high sensor calibration point which may be adjusted for process SG and/or temperature.

CONVERSION_FACTOR: the slope of the factory-set calibration line, based on the selected calibration.

SCALE_OFFSET: the intercept of the calibration line.

4.4.3 Firmware Version

The last parameter in the TRANSDUCER block gives the firmware version of the transmitter.

FIRMWARE_VERSION: displays the version of the firmware.

NOTE: The user should compare the DD file and revision number of the device with the HOST system to ensure they are at the same revision level.

4.5 Analog Input Block

The ANALOG INPUT (AI) block takes the manufacturer's input data and makes it available to other function blocks at its output.

Since only one measured value is available depending on the configuration of the unit, only one channel selection is defined in the AI Function Block. The channel will be identified as "Primary Value," and will also be defined as the default Channel.

4.5.1 AI Block Parameters

PV: Either the primary analog value for use in executing the function, or a process value associated with it.

OUT: The primary analog value calculated as a result of executing the function block.

SIMULATE: Allows the transducer analog input or output to the block to be manually supplied when simulate is enabled. When simulate is disabled, the simulate value and status track the actual value and status.

XD_SCALE: The high and low scale values, engineering units code, and number of digits to the right of the decimal point used with the value obtained from the transducer for a specified channel.

OUT_SCALE: The high and low scale values, engineering units code, and number of digits to the right of the decimal point to be used in displaying the OUT parameter.

GRANT_DENY: Options for controlling access of host computers and local control panels to operating, tuning, and alarm parameters of the block.

IO_OPTS: Option which the user may select to alter input and output block processing.

STATUS_OPTS: Options which the user may select in the block processing of status.

CHANNEL: The number of the logical hardware channel that is connected to this I/O block. This information defines the transducer to be used going to or from the physical world.

L_TYPE: Determines if the values passed by the transducer block to the AI block may be used directly (Direct) or if the value is in different units and must be converted linearly (Indirect), or with square root (Ind Sqr Root), using the input range defined for the transducer and the associated output range.

LOW_CUT: Limit used in square root processing.

PV_FTIME: Time constant of a single exponential filter for the PV, in seconds.

FIELD_VAL: Raw value of the field device in % of PV range, with a status reflecting the Transducer condition, before signal characterization (L_TYPE) or filtering (PV_FTIME).

UPDATE_EVT: This alert is generated by any change to the static data.

BLOCK_ALM: The block alarm is used for all configuration, hardware, connection failure or system problems in the block.

ALARM_SUM: The current alert status, unacknowledged states, unreported states, and disabled states of the alarms associated with the function block.

ACK_OPTION: Selection of whether alarms associated with the function block will be automatically acknowledged.

ALARM_HYS: Amount the PV must return within the alarm limits before the alarm condition clears. Alarm hysteresis expressed as a percent of the span of the PV.

HI_HI_PRI: Priority of the high high alarm.

HI_HI_LIM: The setting for high high alarm in engineering units.

HI_PRI: Priority of the high alarm.

HI_LIM: The setting for high alarm in engineering units

LO_PRI: Priority of the low alarm.

LO_LIM: The setting for low alarm in engineering units.

LO_LO_PRI: Priority of the low low alarm.

LO_LO_LIM: The setting for low low alarm in engineering units.

HI_HI_ALM: The status for high high alarm and its associated time stamp.

HI_ALM: The status for high alarm and its associated time stamp.

LO_ALM: The status for low alarm and its associated time stamp.

LO_LO_ALM: The status for low low alarm and its associated time stamp.

The TRANSDUCER and AI blocks' MODE_BLK parameter must be set to AUTO to pass the PV Value through the AI to the network.

Transducer scaling, called XD_SCALE, is applied to the PV from the CHANNEL to produce the FIELD_VAL in percent. Valid XD_SCALE in engineering units is limited to the four allowable codes of meters (m), centimeters (cm), feet (ft) and inches (in) for units configured for level or interface level measurement. Units configured for density measurement have the engineering unit of specific gravity (sgu).

The AI can have a BLOCK_ERR when:

1. Channel is not set correctly.
2. XD_SCALE does not have suitable engineering units or has range incompatibility.
3. SIMULATE parameter is active
4. AI block MODE is O/S (out of service).

NOTE: This can be caused by the Resource Block being OOS or the AI Block not scheduled for execution.

5. L-TYPE not set or set to Direct with improper OUT_SCALE.

The AI uses the STATUS_OPTS setting and the TRANSDUCER PV LIMIT value to modify the AI PV and OUT QUALITY.

Damping Filter is a feature of the AI block. PV_FTIME parameter is time constant of a single exponential filter for the PV, in seconds. This parameter can be used to dampen out fluctuation in level due to excessive turbulence.

The AI block has multiple ALARM functions that monitor the OUT parameter for out of bound conditions.

4.5.2 Local Display of Analog Input Transducer Block Output

The E3 Modulelevel FOUNDATION fieldbus™ transmitter incorporates a feature that allows the device's Analog Input [AI] block Out value to be displayed on the local LCD.

NOTE: There are many reasons that AI block Out value can deviate from the measurement value originating in the Transducer block, and because the keypad and local display will only provide access to Transducer block parameters, there is no way to explore or change the other fieldbus configuration items affecting the AI block output using the keypad and LCD.

This screen should only be considered as a measured value indicator for configured transmitters.

- The screen is not used for commissioning or diagnostic / troubleshooting purposes.
- Prior to full fieldbus configuration (transmitter assigned a permanent address, AI block configured and scheduled for execution, etc.), the value displayed will not reflect the transducer measurement. (Pre-configuration value will typically be 0).

4.5.2.1 AI Out Display Screen

The Analog Input Out value will be conditionally displayed as part of the “rotating” home menu screens.

The Out value will be displayed subject to limitations necessary for a 6-character display [999999 > Value > -99999].

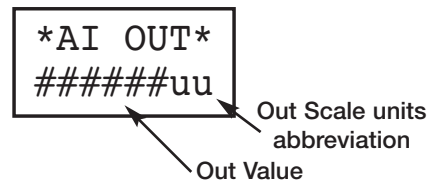

Figure 16
Analog Input Out Display

4.6 PID Block

The PID Function Block contains the logic necessary to perform Proportional/Integral/Derivative (PID) control. The block provides filtering, set point limits and rate limits, feedforward support, output limits, error alarms, and mode shedding.

Although most other function blocks perform functions specific to the associated device, the PID block may reside in any device on the network. This includes valve, transmitter, or the host itself.

The Model E3 PID Block implementation follows the specifications documented by the Fieldbus Foundation.

4.6.1 PID Block Parameters

ACK_OPTION: Used to set auto acknowledgement of alarms.

ALARM_HYS: The amount the alarm value must return to before the associated active alarm condition clears.

ALARM_SUM: The summary alarm is used for all process alarms in the block.

ALERT_KEY: The identification number of the plant unit.

BAL_TIME: The specified time for the internal working value of bias to return to the operator set bias.

BKCAL_IN: The analog input value and status for another blocks BKCAL_OUT output.

BKCAL_HYS: The amount the output must change away from its output limit before the limit status is turned off, expressed as a percent of the span of the output.

BKCAL_OUT: The value and status required by the BKCAL_IN input for another block.

BLOCK_ALM: Used for all configuration, hardware, connection failure, or system problems in the block.

BLOCK_ERR: Reflects the error status associated with the hardware or software components associated with a block.

BYPASS: Used to override the calculation of the block.

CAS_IN: The remote setpoint value from another block.

CONTROL_OPTS: Allows one to specify control strategy options.

DV_HI_ALM: The DV HI alarm data.

DV_HI_LIM: The setting for the alarm limit used to detect the deviation high alarm condition.

DV_HI_PRI: The priority of the deviation high alarm.

DV_LO_ALM: The DV LO alarm data.

DV_LO_LIM: The setting for the alarm limit used to detect the deviation low alarm condition.

DV_LO_PRI: The priority of the deviation low alarm.

FF_GAIN: The feedforward gain value.

FF_SCALE: The high and low scale values associated with FF_VAL.

FF_VAL: The feedforward control input value and status.

GAIN: The proportional gain value. This value cannot equal zero.

GRANT_DENY: Options for controlling access of host computers to alarm parameters of the block.

HI_ALM: The HI alarm data

HI_HI_ALM: The HI HI alarm data

HI_HI_LIM: The setting for the alarm limit used to detect the HI HI alarm condition.

HI_HI_PRI: The priority of the HI HI Alarm.

HI_LIM: The setting for the alarm limit used to detect the HI alarm condition.

HI_PRI: The priority of the HI alarm.

IN: The connection for the PV input from another block.

LO_ALM: The LO alarm data.

LO_LIM: The setting for the alarm limit used to detect the LO alarm condition.

LO_LO_ALM: The LO LO alarm data.

LO_LO_LIM: The setting for the alarm limit used to detect the LO LO alarm condition.

LO_LO_PRI: The priority of the LO LO alarm.

LO_PRI: The priority of the LO alarm.

MODE_BLK: The actual, target, permitted, and normal modes of the block.

OUT: The block input value and status.

OUT_HI_LIM: The maximum output value allowed.

OUT_LO_LIM: The minimum output value allowed.

OUT_SCALE: The high and low scale values associated with OUT.

PV: The process variable use in block execution.

PV_FTIME: The time constant of the first order PV filter.

PV_SCALE: The high and low scale values associated with PV.

RATE: The derivative action time constant.

RCAS_IN: Target setpoint and status that is provided by a supervisory host.

RCAS_OUT: Block setpoint and status that is provided to a supervisory host.

RESET: The integral action time constant.

ROUT_IN: Block output that is provided by a supervisory host.

ROUT_OUT: Block output that is provided to a supervisory host.

SHED_OPT: Defines action to be taken on remote control device timeout.

SP: The target block setpoint value.

SP_HI_LIM: The highest SP value allowed.

SP_LO_LIM: The lowest SP value allowed.

SP_RATE_DN: Ramp rate for downward SP changes.

SP_RATE_UP: Ramp rate for upward SP changes.

STATUS_OPTS: Allows one to select options for status handling and processing.

STRATEGY: Can be used to identify grouping of blocks.

ST_REV: The revision level of the static data associated with the function block.

TAG_DESC: The user description of the intended application of the block.

TRK_IN_D: Discrete input that initiates external tracking.

TRK_SCALE: The high and low scale values associated with TRK_VAL.

TRK_VAL: The value applied to OUT in LO mode.

UPDATE_EVT: This alert is generated by any changes to the static data.

5.0 E3 Modulelevel Menu: Step by Step Procedures

The following table describes the software menu displayed by the E3 Modulelevel FOUNDATION fieldbus™ transmitter for “Level Only” measurement. Use this table as a step by step guide to configure the transmitter.

The second column presents the menus shown on the transmitter display. The displays are in the order they would appear if the arrow keys were used to scroll through the menu. The numbers on the first column are not shown in the display. They are only provided as reference. The third column indicates the password level required to access and change the parameter.

The fourth column provides the actions to take when configuring the transmitter. Additional information or an explanation of an action is given in the fifth column.

5.1 Measurement Type: Level Only

	Display	Password	Action	Comment
1	*Status* *PV-Lvl* *AI Out*	None	Transmitter Display	MeasType = Level
2	PV-Lvl xx.xx lu	None	Transmitter Display	(Alternate Home Menu)
3	AI Out	None	Transmitter Display	(Alternate Home Menu)
4	Proc SG x.xxx sg	User	Enter the specific gravity of the process liquid at operating temp.	Adjusts factory calibration for actual specific gravity
5	ProcTemp xxx F	User	Enter the Process Operating Temperature	Adjusts factory calibration for actual temperature
6	LvlUnits	User	Select the Level Units	Select from cm, inches, feet, meters.
7	Lvl Ofst xx.xx lu	User	Enter desired level reading when level is at the calibrated zero reference	Minimum offset = -(displacer length) Maximum = 960 inches (2438.4 cm)
8	LVDT Damp xx s	User	Select time constant of desired damping	0 to 45 sec
9	Trim Lvl xx.xx lu	User	Enter value to adjust Level reading	Fine tune level reading -10.00 inch to +10.00 inch
10	New Pass xxx	User	Enter new password (0 – 255)	Displays encrypted value of present password Default value = 0
11	Language (select)	User	Select from English, Spanish, French, German	Language choice for LCD display
12	E3 ModFF Ver 1.0	None	Transmitter Display	Product identification Firmware version
13	DispFact (select)	None	Select “Yes” to display factory parameter menu as below	
14	History Status	None	Diagnostic Display to view present status and recent exceptions	

5.1 Measurement Type: Level Only (cont.)

	Display	Password	Action	Comment
15	Run Time xxxx.x h	None	Diagnostic Display showing elapsed time since power on or History Reset	Cleared to zero with History Reset
16	History Reset	SuperUser	Press \leftarrow and select Yes to clear history	
17	MeasType (select)	SuperUser	Select type of measurement	Select from Level, lfcLevel, or Density
18	Model (select)	SuperUser	Select the model number	Select from E3A, E3B, E3C, E3D, E3E, E3F, E31, E32, E33, E34, E35, E36, Custom
19	SpringSG (select)	SuperUser	Select spring SG range	Select 0.29–0.54, 0.55–1.09, 1.10–2.20, HighPres, or Custom
20	SprgRate x.x	SuperUser	Rate of spring in oz/in	Only selectable when custom selected for SpringSG.
21	SprgMat1	SuperUser	Spring Material	Select Inc 600, Inc X750, 316 SS
22	TempLimt xxx F	SuperUser	Enter maximum process temperature	Enter maximum process temperature for which unit is suitable
23	Length xx.xx lu	SuperUser	Enter nominal displacer length	Enter length of measuring range (7 to 240 inches)
24	Diameter x.xxx in	SuperUser	Enter diameter of displacer	Enter outside diameter of displacer (0.5 to 5 inches)
25	Weight xx.x oz	SuperUser	Enter weight of displacer	Enter weight of displacer (40 to 200 ounces)
26	CalSelct (select)	User	Select Factory or User Calibration	Selects Calibration Parameters used to calculate the measured PV.
27a	Factory Cal Menu	None	Press \leftarrow to display the User Calibration sub-menu	CalSelct = Factory Submenu on page 33
27b	User Cal Menu	None	Press \leftarrow to display the User Calibration sub-menu	CalSelct = User Submenu on page 33
28	AdjSnrLo	None	Diagnostic Display	
29	AdjSnrHi	None	Diagnostic Display	
30	Conv Fct xxxx	None	Diagnostic Display	
31	Scl Ofst xxx	None	Diagnostic Display	
32	LVDT% xx.xx %	None	Diagnostic Display	
33	Chan 0	None	Diagnostic Display	
34	Chan 1	None	Diagnostic Display	
35	NodeAddr	SuperUser	Diagnostic Display	Current node address of device
36	NSP Value	SuperUser	Diagnostic Display	
37	ElecTemp xxx C	None	Diagnostic Display	Present temperature in electronics compartment
38	Max Temp xxx C	SuperUser	Diagnostic Display	Maximum electronics temperature recorded
39	Min Temp xxx C	SuperUser	Diagnostic Display	Minimum electronics temperature recorded

5.1 Measurement Type: Level Only (cont.)

Factory Submenu (display only) or User Calibration Submenu

	Display	Password	Action	Comment
1	LVDt% xx.xx %	None	Diagnostic display	
2	Calib SG x.xxx sg	Factory	Factory set	Factory calibration menu only
3	DrySensr xx.xx %	Factory	Enter or capture sensor output for Dry Sensor	Press \uparrow and \leftarrow simultaneously to capture current sensor output
4	SnrCalLo xx.xx %	Factory	Enter or capture sensor output for Low Cal Point	Press \uparrow and \leftarrow simultaneously to capture current sensor output
5	LvlCalLo xx.xx lu	Factory	Enter Level value corresponding to SnrCalLo	
6	SnrCalHi xx.xx %	Factory	Enter or capture sensor output for High Cal Point	Press \uparrow and \leftarrow simultaneously to capture current sensor output
7	LvlCalHi xx.xx lu	Factory	Enter Level value corresponding to SnrCalHi	
8	Escape	None	Press \leftarrow to exit Calibration sub-menu; Returns to Factory Menu	

6.0 Diagnostic Parameters

The E3 Modulelevel measurement engine runs through a series of self-tests and will detect and report faulty operation. The Modulelevel TRANSDUCER BLOCK displays these faults in the DEVICE_STATUS parameter. Refer to Section 8.3.3 for more information on specific faults and warnings.

BLOCK_ERROR is not used except for indicating Out of Service (OOS).

When the Model E3 transmitter is initially powered on, the measurement engine does not have enough valid measurement cycles to make a decision about the output level. For the first twenty-two measurement cycles after power is applied, the QUALITY is “Uncertain,” the SUB_STATUS is “Initial value,” and the LIMIT attribute is “Constant.”

When the Model E3 is operating correctly, the QUALITY is shown as “GOOD,” and the SUB_STATUS is “Non-Specific.”

While changing the transmitter operational parameters using the local display or through the system configuration tool (with the MODE_BLK in OOS), the output might be inaccurate because of the changing parameters. When the device is in a mode where operational parameters can be changed, the Modulelevel TRANSDUCER BLOCK will still output level but the QUALITY will be shown as “Bad” and the SUB_STATUS is “Out of Service.”

If the Model E3 indicates a fault condition, the Modulelevel TRANSDUCER BLOCK maintains the last good value as the output and flags the failure. The QUALITY is “Bad,” the SUB_STATUS is “Sensor failure” (or “Device failure”), and the LIMIT attribute is set appropriately. Refer to Section 8.3.3.

6.1 Simulation Feature

The E3 Modulelevel with FOUNDATION fieldbus™ supports the Simulate feature in the Analog Input block. The Simulate feature is typically used to exercise the operation of an AI block by simulating a TRANSDUCER block input.

This feature can not be activated without the placement of a hardware jumper. This jumper is installed as standard on the Model E3, and is placed in an inconvenient location to avoid inadvertent disabling of this feature.

NOTE: A BLOCK_ERR of “Simulation” in the Resource Block indicates that the simulation enabling hardware jumper is present.

Contact the factory for instructions on how to remove this jumper and permanently disable the Simulate feature.

7.0 Documentation

The following two tables are examples of data sheets describing what information is need to fully specify a Fieldbus device. The first table shows one device per page, while table 2 is intended for multiple devices.

Refer to “FOUNDATION fieldbus™ System Engineering Guidelines—AG-181” for additional information. This document can be found at www.fieldbus.org.

7.1 Fieldbus Data Sheet for Individual Instrument

Fieldbus Function Blocks	Segment Information	Miscellaneous Information
<input type="checkbox"/> Analog Input (AI) _____ Number _____ Execution Time (msec)	<input type="checkbox"/> Arithmetic (A) _____ Execution Time (msec) <input type="checkbox"/> Digital Alarm (DA) _____ Execution Time (msec)	Device: Segment # _____
<input type="checkbox"/> Discrete Input (DI) _____ Number _____ Execution Time (msec)	<input type="checkbox"/> Calculate _____ Execution Time (msec) <input type="checkbox"/> Analog Alarm (AA) _____ Execution Time (msec)	LAS Capable: <input type="checkbox"/> YES <input type="checkbox"/> NO Device current draw (mA): In-rush current (mA):
<input type="checkbox"/> Bias/Gain Settings (BG) _____ Execution Time (msec)	<input type="checkbox"/> Deadtime (D) _____ Execution Time (msec)	Device Lift-off (minimum) voltage:
<input type="checkbox"/> Manual Loader _____ Execution Time (msec)	<input type="checkbox"/> Complex Analog Output (CAO) _____ Execution Time (msec)	Device capacitance:
<input type="checkbox"/> Proportional/Integral/Derivative (PID) _____ Execution Time (msec)	<input type="checkbox"/> Step Output PID (SOPID) _____ Execution Time (msec)	Polarity Sensitive: <input type="checkbox"/> YES <input type="checkbox"/> NO
<input type="checkbox"/> Analog Output (AO) _____ Number _____ Execution Time (msec)	<input type="checkbox"/> Set Point Ramp Generator _____ Execution Time (msec)	DD Revision:
<input type="checkbox"/> Discrete Output (DO) _____ Number _____ Execution Time (msec)	<input type="checkbox"/> Signal Characterizer (SC) _____ Execution Time (msec)	CFF Revision: Tested with ITK revision
<input type="checkbox"/> Control Selector (CS) _____ Execution Time (msec)	<input type="checkbox"/> Digital Human Interface (DHI) _____ Execution Time (msec)	NOTES:
<input type="checkbox"/> Proportional/Derivative (PD) _____ Execution Time (msec)	<input type="checkbox"/> _____ _____ Execution Time (msec)	
<input type="checkbox"/> Ratio _____ Number _____ Execution Time (msec)		

7.2 Fieldbus Data Sheet for Multiple Devices

TAG NUMBER	1	2	3	4	5	6	7	8	9	10	11	12
Number of AIs												
AI Execution Time (msec)												
Number of AOs												
AO Execution Time (msec)												
Number of SSs												
SS Execution Time (msec)												
Number of TOTs												
TOT Execution Time (msec)												
Number of ARs												
AR Execution Time (msec)												
Number of PIDs												
PID Execution Time (msec)												
Number of _____												
Execution Time												
Number of _____												
Execution Time												
Number of _____												
Execution Time												
Number of _____												
Execution Time												
Number of _____												
Execution Time												
Number of _____												
Execution Time												
Channel												
I.S. Segment (If applicable)												
LAS Capable (Yes/No)												
DD Revision												
ITK Revision												
Polarity Sensitive (Yes/No)												
CFF Revision												

8.0 Reference Information

This section presents an overview of the operation of the E3 Electronic Modulelevel Displacer Level Transmitter, information on troubleshooting common problems, listings of agency approvals, lists of replacement and recommended spare parts, and detailed physical, functional, and performance specifications.

8.1 Description

The E3 Modulelevel is a level transmitter which utilizes simple buoyancy principles in combination with a precision range spring and a highly accurate LVDT (linear variable differential transformer) to detect and convert liquid level movement into a stable output value. The electronics are housed in an ergonomic, dual-compartment enclosure which is angled for ease of wiring and calibration.

8.2 Theory of Operation

The Electronic Modulelevel Displacer Level Transmitter relies on the principles of buoyancy to convert mechanical movement to an electronic output. See Figure 17.

8.2.1 Displacer/Range Spring

According to Archimedes principle, the buoyancy force acting on an object immersed in liquid is equal to the mass of the liquid displaced. As the level changes, the volume of displacer submerged in the liquid changes, thus varying the buoyancy force acting on the displacer. This change is detected by the precision range spring from which the displacer hangs, causing it to elongate or compress. The change in spring length causes movement of a special LVDT core which is mounted on a rigid stem attached to the spring.

8.2.2 LVDT

E3 Modulelevel utilizes highly precise LVDT technology to convert the movement of the LVDT core within the LVDT to a stable output value. The position of the core with respect to a primary and two secondary windings within the LVDT, induces a voltage in each winding. The comparison of the induced voltages within the microprocessor of the E3 results in very accurate level output.

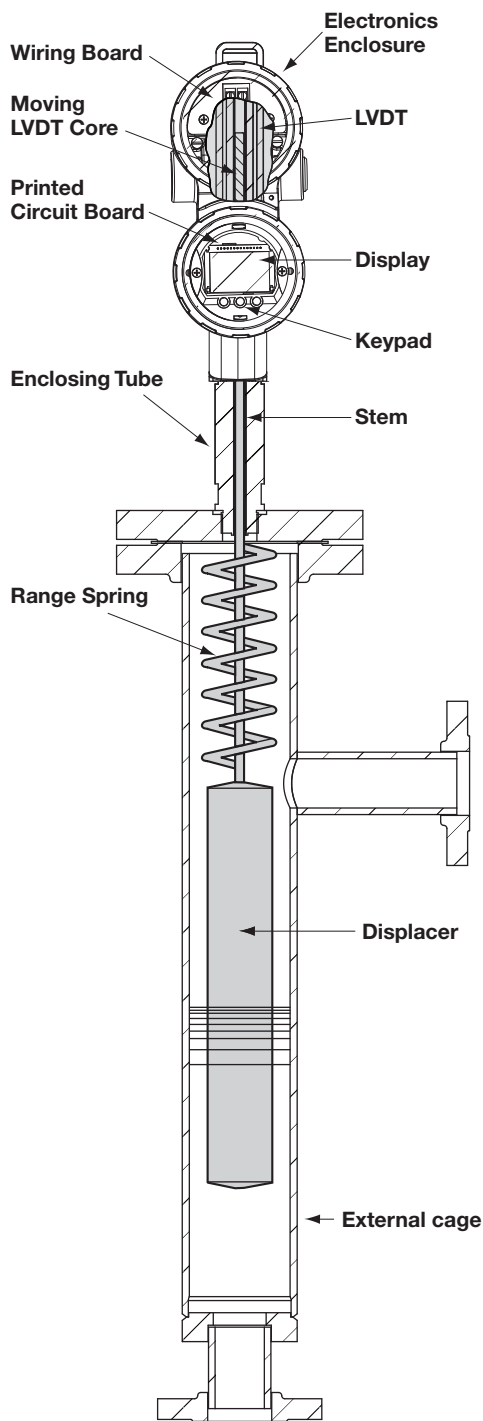

Figure 17
Electronic Modulelevel
Components

8.2.3 Interface

E3 Modulelevel is capable of tracking the interface level of two immiscible liquids with different densities. The unit is equipped with a specially designed displacer which allows it to detect the position of a clean interface or an emulsion layer and convert it into a stable output value.

8.2.4 Density

Yet another capability of E3 Modulelevel is to track the changing density of a liquid over a known density range and convert that into a stable output value. As the density of the liquid changes, so does the mass of the liquid displaced by the specially designed displacer. The resulting change in buoyancy force on the displacer causes the movement of the LVDT core necessary to convert the density change to an output value.

8.3 Troubleshooting

The E3 Modulelevel displacer transmitter is designed, engineered and constructed for trouble-free operation over a wide range of operating and application conditions. Below, common transmitter problems are discussed in terms of their symptoms and corrective actions.

WARNING! Explosion hazard. Do not remove covers unless power has been switched off or the area is known to be non-hazardous.

8.3.1 Troubleshooting System Problems

Symptom	Problem	Solution
No output signal.	Power supply not turned on.	Turn on power.
	Insufficient source voltage.	Minimum of 9 VDC required at the wiring board. Verify supply voltage.
	Improperly wired or damaged wiring.	Check wiring and connections.
	Defective electronics.	Replace PC board assembly or wiring board as required.
LEVEL and % OUTPUT values are inaccurate.	Basic configuration data is questionable.	Verify Level Offset values. If using factory calibration, verify that Process SG and Operating Temperature values are accurate. Verify/confirm that Model Parameters are accurate. Confirm set points are as expected.
Transmitter does not track level.	Model incompatible with process liquid	Verify model in use is appropriate for process liquid SG.
	Possible damage to unit.	Check displacer, spring, stem and enclosing tube for damage. Replace all damaged parts.
	Possible material buildup	Check displacer, spring, stem, enclosing tube and displacer for buildup of process material. Clean any fouled parts.
	Displacer, spring or stem dragging on inside of chamber, e-tube.	Verify proper and level installation (within 3 degrees of plumb in all directions).
LEVEL and % OUTPUT values fluctuate.	Liquid turbulence.	Increase damping until output stabilizes or install stilling well.
	Power supply unstable.	Repair or replace power supply.
	Electrical interference (RFI).	Consult factory for assistance.
Output jumps quickly over wide range	Bent stem impeding smooth core movement	Review Status History for Surge event. Inspect stem and replace if damaged.
Non-linear output.	Displacer hanging up.	Verify proper and level installation (within 3 degrees of plumb in all directions.)
	Bent stem.	Check stem. Replace if damaged.
	Possible material buildup	Check displacer, spring, stem, enclosing tube and displacer for buildup of process material. Clean any fouled parts.

8.3.2 Checking the LVDT Winding Resistance

WARNING: To prevent ignition of explosive atmospheres, disconnect power before servicing.

Refer to Figure 18 during this procedure.

1. Remove power from the unit.
2. Remove the electronics housing cover and the electronics bezel assembly.
3. Disconnect the six-pin connector J1 from the back of the PC board assembly.
4. Using a multimeter, check the primary winding by verifying that pins 1 and 4 of the six-pin connector have approximately 75 to 105 ohms resistance.
5. Check the secondary winding by verifying that pins 2 and 5 or pins 3 and 6 of the six-pin connector have approximately 70 to 100 ohms resistance.
6. If the winding resistance is out of range, replace LVDT.

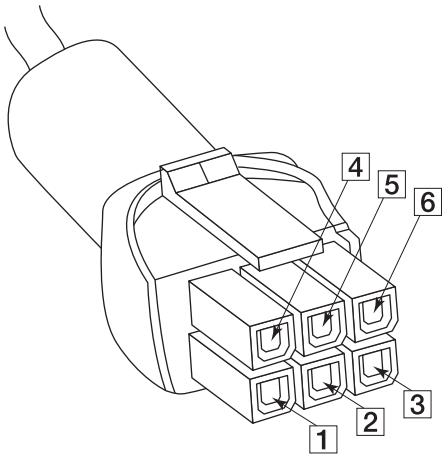

Figure 18
LVDT Six-Pin Connector

8.3.3 Device Status Parameter in the Transducer Block

The following table lists the conditions indicated in the Device Status parameter. It also shows the affect the condition has on PV status, Sub-Status and Limit, XD ERROR and BLOCK ALARM are not affected by these conditions directly.

Device Status				PV Status Quality	PV Sub Status	Limit
Type	Label	Bit #	Value			
Mode	OK	11	0x0800	Good	Non-Specific	Not Limited
Mode	User Access	2	0x0004	Bad	OOS	Not Limited
Mode	Factory Access	14	0x4000	Bad	OOS	Not Limited
Faults	Default Params	12	0x1000	Bad	Configuration Error	Not Limited
Faults	Primary Fault	9	0x0200	Bad	Device Failure	Constant Limited
Faults	Core Drop	8	0x0100	Bad	Sensor Failure	Low Limited
Faults	SecFaultHi	10	0x0400	Bad	Sensor Failure	High Limited
Faults	SecFaultLo ①	13	0x2000	Bad	Sensor Failure	Low Limited
Warning	Default Cal	5	0x0020	No Effect	No Effect	No Effect
Warning	Hi Temperature	4	0x0010	No Effect	No Effect	No Effect
Warning	Lo Temperature	3	0x0008	No Effect	No Effect	No Effect
Warning	Cal Span	6	0x0040	No Effect	No Effect	No Effect
Warning	Initializing	1	0x0002	Uncertain	Initial Value	Constant Limited
Faults	Fault 1	15	0x8000	No Effect	No Effect	No Effect
Warning	Warning 2	0	0x0001	No Effect	No Effect	No Effect
Warning	Warning 1	7	0x0080	No Effect	No Effect	No Effect

① This fault disabled with interface or density measurement.

The first three conditions are Type Mode. If everything is running normally and there are no Faults or Warnings, then the device indicates it is “OK” an the local display and in Device Status viewed from the FOUNDATION fieldbus™ network. If a password is entered through the local display, the Transducer Block is taken Out of Service if it is not already and the User Access or Factory Access will be indicated in Device Status viewed from the FOUNDATION fieldbus. This will indicate to the operator that an attempt is being made to modify a parameter value. No indication is given on the Fieldbus network if someone is only viewing parameters on the local display.

The next set of conditions is device faults. The device will most likely not be able to measure level correctly if one or more of these conditions occur. The condition will be indicated in Device Status and will affect PV Status, Sub-Status and Limit as indicated.

The next set of conditions is the device warnings. The condition will not jeopardize the level measurement. However, knowledge of the condition may be useful in troubleshooting the device.

The following table describes the conditions that can be seen in Device Status:

Display Message	Action	Comment
OK	None	Normal operating mode.
User Access	Password at the local display.	Parameter values are being changed through the local interface. Make sure Transducer Block is taken out of service.
Factory Access	Password at the local display.	Parameter values are being changed through the local interface. Make sure Transducer Block is taken out of service.
Default Params	Internal non-volatile parameters have been defaulted.	Consult factory.
Primary Fault	LVDT Primary circuit open condition.	Check LVDT winding resistance. Replace LVDT if values are out of range.
Core Drop	Core too far out.	Check for lost or damaged LVDT core.
Sec Fault Hi	A/D readings from LVDT secondary windings are above expected range.	Check for missing displacer.
Sec Fault Lo	A/D readings from LVDT secondary windings are below expected range.	Check for broken spring or leaking displacer. This fault disabled when measurement type is interface or density.
Default Cal	Factory set default calibration parameters are in use. Level reading may be inaccurate.	Consult factory.
Hi Temperature	Present temperature in electronics compartment is above 80 C.	1) Transmitter may need to be moved to ensure ambient temperature is within specification. 2) Change to remote mount transmitter.
Lo Temperature	Present temperature in electronics compartment is below - 40 C.	1) Transmitter may need to be moved to ensure ambient temperature is within specification. 2) Change to remote transmitter.
Cal Span	Span between Sensor Calibration Hi and Lo values is less than minimum span.	Recalibrate or reconfigure unit with longer span
Initializing	None	Program is initializing. This is a transient condition.

8.3.4 FF Segment Checklist

There can be several reasons for a FOUNDATION fieldbus™ installation to be in a faulty condition. In order to assure that communication can be established, the following requirements must be met.

- Device supply voltage must be higher than 9 VDC with a maximum of 32 VDC.
- Total current draw of a given segment cannot exceed the rating shown on the power conditioner and/or barrier.
- Device polarity must be correct.
- Two 100 Ω, 1 μF terminators must be connected to the network—one at each end of the segment.
- Cable length plus spur length must not exceed the following values:

Number of Spurs	1 Device	2 Devices	3 Devices	4 Devices
25–32	—	—	—	—
19–24	100 ft. (30 m)	—	—	—
15–18	200 ft. (60 m)	100 ft. (30 m)	—	—
13–14	300 ft. (90 m)	200 ft. (60 m)	100 ft. (30 m)	—
1–12	400 ft. (120 m)	300 ft. (90 m)	200 ft. (60 m)	100 ft. (30 m)

Pair	Shield	Twisted	Size	Length	Type
Single	Yes	Yes	AWG 18 (0.8 mm ²)	6,200 ft. (1,900 m)	A
Multi	Yes	Yes	AWG 22 (0.32 mm ²)	3,900 ft. (1,200 m)	B
Multi	No	Yes	AWG 26 (0.13 mm ²)	1,300 ft. (400 m)	C
Multi	Yes	No	AWG 16 (1.25 mm ²)	650 ft. (200 m)	D

- The cable shield is to be hard grounded only at one point close to the DCS. In addition, the cable shield can be capacitively grounded in multiple places to improve EMC protection.
- Ensure all devices are on the “live list,” and the schedule has been downloaded.
- Ensure the device identity is in the Resource Block.
- Ensure that the Resource Block, then the Transducer Block, and lastly the Function Block(s) are in “Auto” mode rather than Out of Service (OOS).

If all of these requirements are met, a stable communication should be established.

8.4 Agency Approvals

8.4.1 FM (Factory Mutual)

Agency	Model	Approval
FM 	XEXX-XXXX with transmitter codes:	Explosion Proof ③ Class I, Div. 1; Groups B, C, D Class II, Div. 1; Groups E, F, G Class III, T5 Type 4X, IP66
	XEXX-XXXX with transmitter codes:	Intrinsically Safe Class I, Div. 1; Groups A, B, C, D Class II, Div. 1; Groups E, F, G Class III, T4 Entity/FISCO ① Type 4X, IP66
	XEXX-XXXX with transmitter codes:	Non-Incendive Class I, Div. 2; Groups A, B, C, D Class II, Div. 2; Groups E, F, G Class III, Div. 2; T4 Type 4X, IP66
	XEXX-XXXX with transmitter codes:	Explosion Proof ③ Class I, Div. 1; Groups B, C, D Class II, Div. 1; Groups E, F, G Class III, T5 Type 4X, IP66
	XEXX-XXXX with transmitter codes:	Intrinsically Safe Class I, Div. 1; Groups A, B, C, D Class II, Div. 1; Groups E, F, G Class III, T4 Entity/FISCO ① Type 4X, IP66
	XEXX-XXXX with transmitter codes:	Non-Incendive Class I, Div. 2; Groups A, B, C, D Class II, Div. 2; Groups E, F, G Class III, Div. 2; T4 Type 4X, IP66
	XEXX-XXXX with transmitter codes:	Explosion Proof ③ Class I, Div. 1; Groups B, C, D Class II, Div. 1; Groups E, F, G Class III, T5 Type 4X, IP66
	XEXX-XXXX with transmitter codes:	Intrinsically Safe Class I, Div. 1; Groups A, B, C, D Class II, Div. 1; Groups E, F, G Class III, T4 Entity/FISCO ① Type 4X, IP66
	XEXX-XXXX with transmitter codes:	Suitable for: Class I, Div. 2; Groups A, B, C, D Class II, Div. 2; Groups E, F, G Class III, T4 Type 4X, IP66

8.4.2 CSA (Canadian Standards Association)

Agency	Model	Approval
CSA 	XEXX-XXXX with transmitter codes:	Explosion Proof ③ Class I, Div. 1; Groups B, C, D Class II, Div. 1; Groups E, F, G Class III, T5 Type 4X, IP66
	XEXX-XXXX with transmitter codes:	Intrinsically Safe Class I, Div. 1; Groups A, B, C, D Class II, Div. 1; Groups E, F, G Class III, T4 Entity/FISCO ① Type 4X, IP66
	XEXX-XXXX with transmitter codes:	Suitable for: Class I, Div. 2; Groups A, B, C, D Class II, Div. 2; Groups E, F, G Class III, T4 Type 4X, IP66
	XEXX-XXXX with transmitter codes:	Explosion Proof ③ Class I, Div. 1; Groups B, C, D Class II, Div. 1; Groups E, F, G Class III, T5 Type 4X, IP66
	XEXX-XXXX with transmitter codes:	Intrinsically Safe Class I, Div. 1; Groups A, B, C, D Class II, Div. 1; Groups E, F, G Class III, T4 Entity/FISCO ① Type 4X, IP66
	XEXX-XXXX with transmitter codes:	Suitable for: Class I, Div. 2; Groups A, B, C, D Class II, Div. 2; Groups E, F, G Class III, T4 Type 4X, IP66
	XEXX-XXXX with transmitter codes:	Explosion Proof ③ Class I, Div. 1; Groups B, C, D Class II, Div. 1; Groups E, F, G Class III, T5 Type 4X, IP66
	XEXX-XXXX with transmitter codes:	Intrinsically Safe Class I, Div. 1; Groups A, B, C, D Class II, Div. 1; Groups E, F, G Class III, T4 Entity/FISCO ① Type 4X, IP66
	XEXX-XXXX with transmitter codes:	Suitable for: Class I, Div. 2; Groups A, B, C, D Class II, Div. 2; Groups E, F, G Class III, T4 Type 4X, IP66

8.4.3 ATEX (European Directive for Explosion Protection)

Agency	Model		Approval/Standards
ATEX 	XEXX-XXXX, EXX-XXXX with transmitter codes	x1E, x1F, x1G, x1H	Flameproof ATEX Ex II 1/2 G Ex d IIC T6 EN 60079-0 EN 60079-1 EN 60079-26 94/9/EC
		x2E, x2F, x2G, x2H	
		x3E, x3F, x3G, x3H	
	XEXX-XXXX, EXX-XXXX with transmitter codes	x1A, x1B, x1C, x1D	Intrinsically Safe ② ATEX Ex II 1 G Ex ia IIC T4 EN 60079-0 EN 60079-11 EN 60079-26 EN 60079-27 94/9/EC
		x2A, x2B, x2C, x2D	
		x3A, x3B, x3C, x3D	
	XEXX-XXXX, EXX-XXXX with transmitter codes	x1A, x1B, x1C, x1D	Non-Sparking ATEX Ex II 3 G Ex ic II T6 EN 60079-0 EN 60079-11 94/9/EC
		x2A, x2B, x2C, x2D	
		x3A, x3B, x3C, x3D	
IEC	XEXX-XXXX, EXX-XXXX with transmitter codes	x1E, x1F, x1G, x1H	Flameproof IECEx Ex d IIC T6 Ga/Gb IEC 60079-0 IEC 60079-1 IEC 60079-26
		x2E, x2F, x2G, x2H	
		x3E, x3F, x3G, x3H	
	XEXX-XXXX, EXX-XXXX with transmitter codes	x1A, x1B, x1C, x1D	Intrinsically Safe ② IECEx Ex ia IIC T4 Ga IEC 60079-0 IEC 60079-11 IEC 60079-26 IEC 60079-27
		x2A, x2B, x2C, x2D	
		x3A, x3B, x3C, x3D	



These units have been tested to EN 61326 and are in compliance with the EMC Directive 2004/108/EC.

① Entity parameters for intrinsically safe installation (FM & CSA):

non-FISCO
 $V_{\max} = 28.6 \text{ V}$
 $I_{\max} = 140 \text{ mA}$
 $P_{\max} = 1 \text{ W}$
 $C_i = 5.5 \text{ nF}$
 $L_i = 9.4 \text{ }\mu\text{H}$

for FISCO Intrinsically Safe

$V_{\max} = 17.5 \text{ V}$
 $I_{\max} = 500 \text{ mA}$
 $P_{\max} = 5.5 \text{ W}$
 $C_i \leq 5 \text{ nF}$
 $L_i \leq 10 \text{ }\mu\text{H}$

② Entity parameters for intrinsically safe installation (ATEX/IEC):

non-FISCO
 $U_i = 28.4 \text{ V}$
 $I_{\max} = 94 \text{ mA}$
 $P_{\max} = 0.67 \text{ W}$
 $C_i = 2.2 \text{ nF}$
 $L_i = 3 \text{ }\mu\text{H}$

for FISCO Intrinsically Safe

$U_i = 17.5 \text{ V}$
 $I_{\max} = 380 \text{ mA}$
 $P_{\max} = 5.32 \text{ W}$
 $C_i = 0.705 \text{ nF}$
 $L_i = 3 \text{ }\mu\text{H}$

③ On remote electronics housing only, seal is required within 18 inches.

8.4.4 Agency Drawings

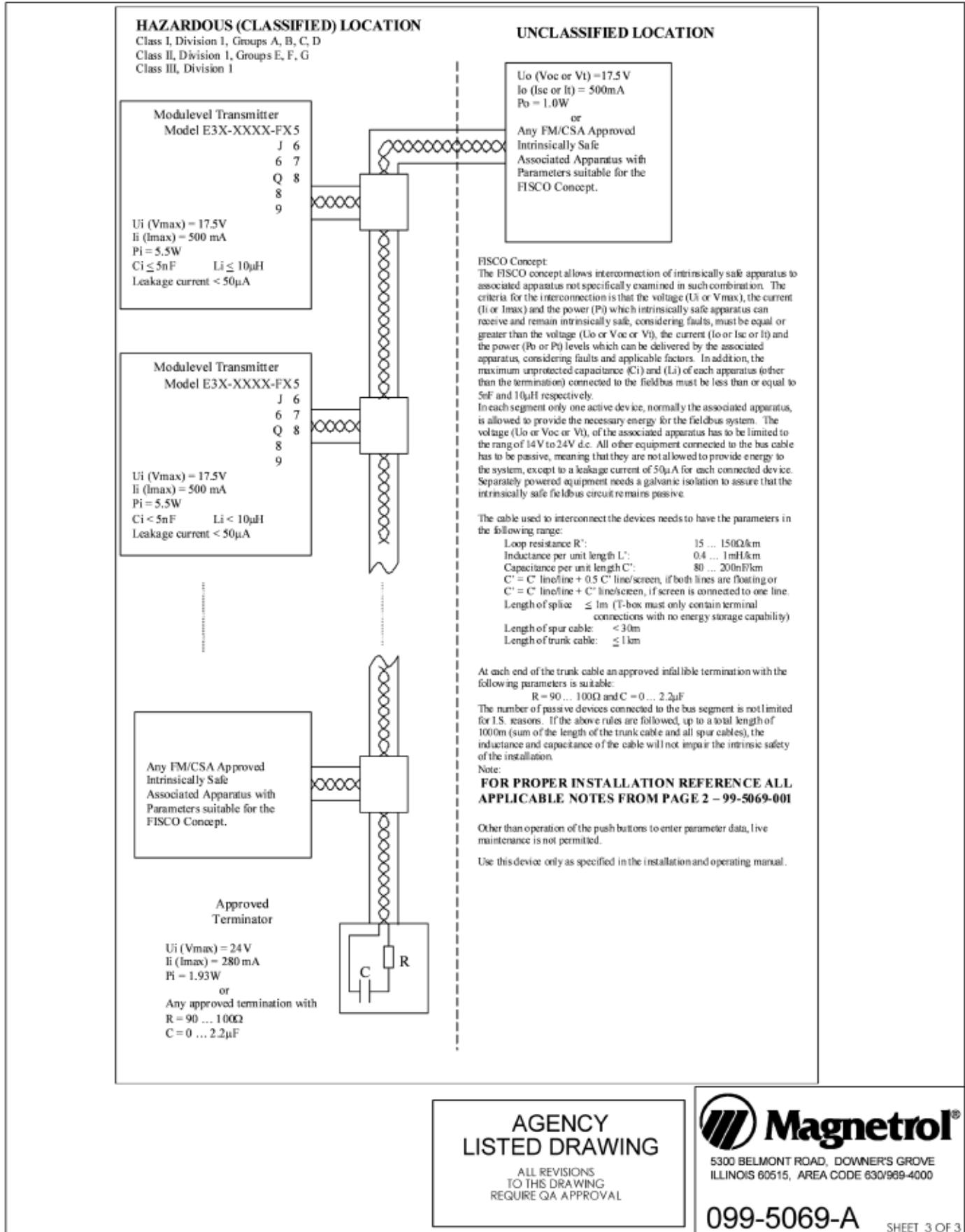

8.5 Parts

8.5.1 Replacement Transmitter Head Parts

① Electronic Module FOUNDATION fieldbus	Z31-2845-001*
② Wiring Board	
FOUNDATION fieldbus XP	Z30-9151-003
FOUNDATION fieldbus IS	Z30-9151-004
③ Transmitter Housing O-rings (2 required)	012-2201-237
④ Transmitter Housing Cover Kits – Contains parts 4a and 4b	
ATEX/IEC & FM/CSA, aluminum, IS, integral	089-6606-004
ATEX/IEC & FM/CSA, stainless steel, IS, integral	089-6606-005
FM/CSA, aluminum, XP, integral	089-6606-009
FM/CSA, stainless steel, XP, integral	089-6606-010
ATEX/IEC, aluminum, XP, integral	089-6606-013
ATEX/IEC, stainless steel, XP, integral	089-6606-014
FM/CSA, aluminum, XP, remote	089-6606-015
FM/CSA, stainless steel, XP, remote	089-6606-016
FM/CSA, aluminum, IS, remote	089-6606-017
FM/CSA, stainless steel, IS, remote	089-6606-018
④c Terminal Junction Box Covers (2 required)	
FM/CSA, aluminum, XP, remote	Consult Factory
FM/CSA, stainless steel, XP, remote	Consult Factory
FM/CSA, aluminum, IS, remote	Consult Factory
FM/CSA, stainless steel, IS, remote	Consult Factory
⑤ LVDT Kit – Contains parts 5, 8, 9, and 10	
Low Temperature (9 th digit 1 or 4)	089-7827-007*
Mid Temperature (9 th digit 2 or 5)	089-7827-008*
High Temperature (9 th digit 3 or 6)	089-7827-009*
⑥ LVDT Housing Cover Kits	
Aluminum	089-7827-001
Stainless Steel	089-7827-002
⑦ LVDT Cover O-ring	012-2222-123
⑪ Remote Terminal Boards (2 required)	030-3609-001
⑫ Remote Transmitter Jumper Cable	037-7917-001
⑬ Remote Cable Assembly (last two digits indicate cable length in feet)	
Up to +400° F (+204° C)	037-3226-0xx
Up to +500° F (+260° C)	037-3227-0xx

* Field replacement of this part requires a user calibration of the repaired unit.

Parts Identification

1 Electronic Module	7 LVDT Cover O-ring
2 Wiring Board	8 TFE Spacer
3 Transmitter Housing O-rings (2)	9 Grip Ring
4a Meter/Bezel Compartment Cover	10 Top LVDT Spacer
4b Wiring Compartment Housing Cover	11 Remote Terminal Boards (2)
4c Terminal Junction Box Covers (2)	12 Remote Transmitter Jumper Cable
5 LVDT Assembly	13 Remote Cable Assembly
6 LVDT Housing Cover	

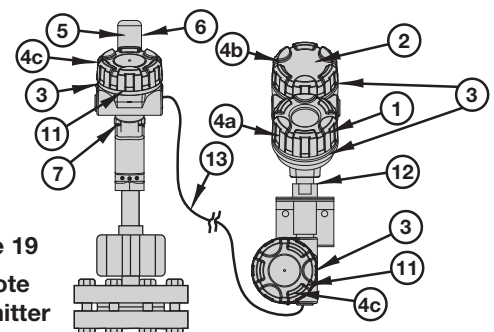

Figure 19
Remote Transmitter

8.5.2 Mechanical Replacement Parts

Cage Pressure Rating	Temperature Configuration 4th digit	Spring SG Range	E-tube Kits		Stem Kit*	Spring Kits*			
			Carbon Steel	316 SS		Inconel®	316 SS		
150#, 300# & 600# ANSI	A, B, C	0.23 – 0.54	89-5958-002	89-5958-006	89-5565-004	89-5340-002	n/a		
		0.55 – 1.09			89-5565-003	89-5340-005			
		1.10 – 2.20			89-5565-003	89-5340-008			
	D, E, F	0.23 – 0.54	89-5958-004	89-5958-008	89-5565-008	89-5340-003			
		0.55 – 1.09			89-5565-007	89-5340-006			
		1.10 – 2.20			89-5565-007	89-5340-009			
	J, K, L	0.23 – 0.54	89-5958-001	89-5958-005	89-5565-002	89-5340-002	89-5340-001		
		0.55 – 1.09			89-5565-001	89-5340-005	89-5340-004		
		1.10 – 2.20			89-5565-001	89-5340-008	89-5340-007		
	M, N, P Temperatures ≤ +450° F (+230° C)	0.23 – 0.54	89-5958-003	89-5958-007	89-5565-006	89-5340-002	n/a		
		0.55 – 1.09			89-5565-005	89-5340-005			
		1.10 – 2.20			89-5565-005	89-5340-008			
	M, N, P Temperatures ≥ +500° F (+260° C)	0.23 – 0.54	89-5958-003	89-5958-007	89-5565-006	89-5340-003	n/a		
		0.55 – 1.09			89-5565-005	89-5340-006			
		1.10 – 2.20			89-5565-005	89-5340-009			
900# ANSI	B	0.55 – 1.09	89-5958-010	89-5958-014	89-5565-004	89-5340-010	n/a		
	E		89-5958-012	89-5958-016	89-5565-008				
	K		89-5958-009	89-5958-013	89-5565-002				
	N		89-5958-011	89-5958-015	89-5565-006				
1500# & 2500# ANSI	B	0.55 - 1.09	89-5958-010	n/a	89-5565-004			89-5340-010	n/a
	E		89-5958-012		89-5565-008				
	K		89-5958-009		89-5565-002				
	N		89-5958-011		89-5565-006				

* Field replacement of this part requires a user calibration of the repaired unit.

Cage Pressure Rating	Head Flange Size	⑰ Head Flange Kit	
		Carbon Steel	316 SS
150# ANSI	3"	89-4242-001	89-4242-017
	4"	89-4242-005	89-4242-021
	6"	89-4242-011	89-4242-027
300# ANSI	3"	89-4242-002	89-4242-018
	4"	89-4242-006	89-4242-022
	6"	89-4242-012	89-4242-028
600# ANSI	3"	89-4242-003	89-4242-019
	4"	89-4242-007	89-4242-023
	6"	89-4242-013	89-4242-029
900# ANSI	3"	89-4242-004	89-4242-020
	4"	89-4242-008	89-4242-024
	6"	89-4242-014	89-4242-030
1500# ANSI	4"	89-4242-009	89-4242-025
	6"	89-4242-015	89-4242-031
2500# ANSI	4"	89-4242-010	89-4242-026
	6"	89-4242-016	89-4242-032

⑱ Displacer Kits*			
	150, 300, 600#		High Pressure 900, 1500, 2500#
	S.G. Range 0.23-0.54 & 0.55-1.09		S.G. Range 1.10 - 2.2
	S.G. Range 0.55 - 1.09		
14"	89-6125-001	89-6126-001	89-6125-010
32"	89-6125-002	89-6126-002	89-6125-011
48"	89-6125-003	89-6126-003	89-6125-012
60"	89-6125-004	89-6126-004	89-6125-013
72"	89-6125-005	89-6126-005	n/a
84"	89-6125-006	89-6126-006	n/a
96"	89-6125-007	89-6126-007	n/a
108"	89-6125-008	89-6126-008	n/a
120"	89-6125-009	89-6126-009	n/a

⑲ Cotter pins	
All Units	10-5203-001

Kit Definitions

Head flange kit includes: head flange, studs, nuts and gasket (top mounting units) or head flange only (chambered unit)

E-tube kits include: E-tube, E-tube extension(s) and gasket

Stem kits include: stem assembly, stem extension, LVDT core

Spring kits include: spring assembly, screws and lockwashers

Displacer kits include: displacer and cotter pins

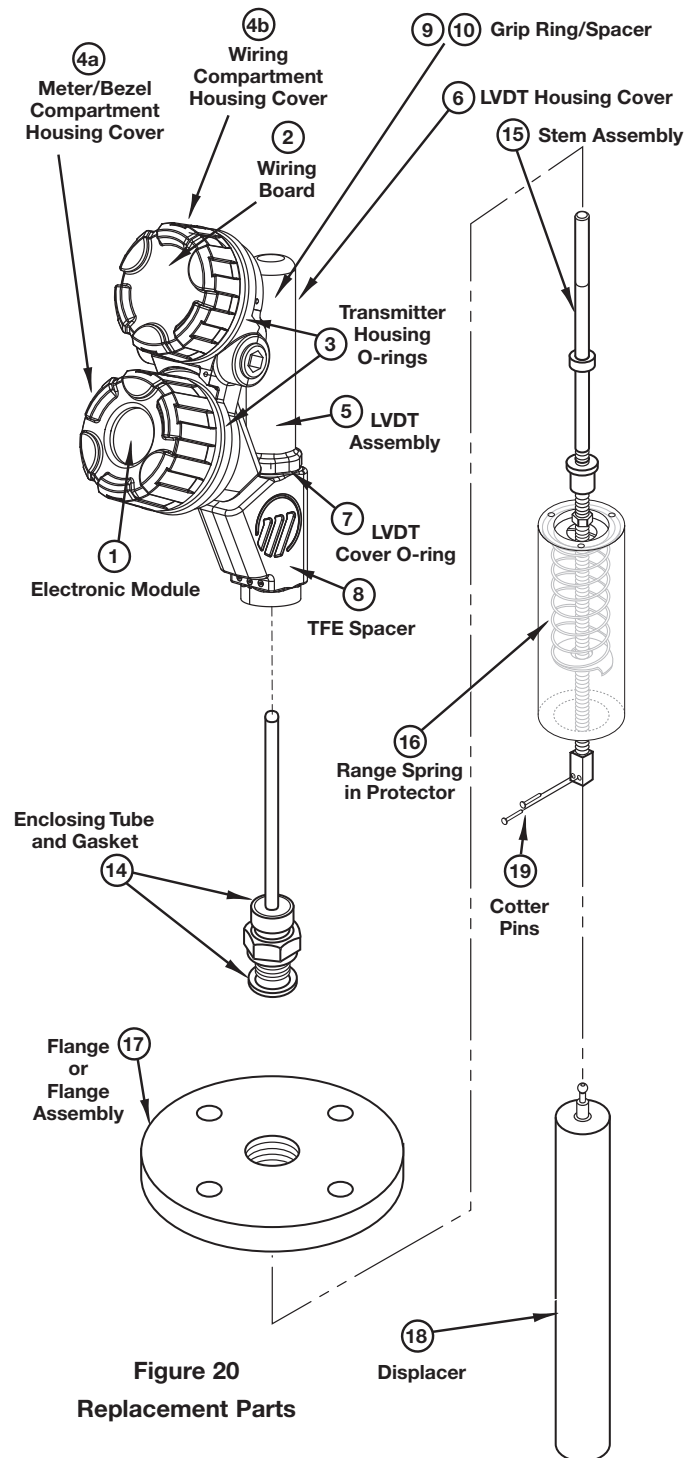

Figure 20
Replacement Parts

8.5.3 Recommended Spare Parts

① Electronic Module	
FOUNDATION fieldbus	Z31-2845-001*

⑤ LVDT Assembly Kit	
Low Temperature (9 th digit 1 or 4)	89-7827-007*
Mid Temperature (9 th digit 2 or 5)	89-7827-008*
High Temperature (9 th digit 3 or 6)	89-7827-009*

* Field replacement of this part requires a user calibration of the repaired unit.

8.6 Specifications

8.6.1 Functional

System Design

Measurement Principle Buoyancy – continuous displacement utilizing a precision range spring

Input

Measured Variable Level, determined by LVDT core movement affected by buoyancy force changes on continuous displacer

Physical Range Up to 120" (300 cm) based on displacer length (C/F for longer ranges)

User Interface

Keypad 3-button menu-driven data entry and system security

Indication 2-line × 8-character LCD display

Digital Communication FOUNDATION fieldbus™, H1 (31.25 kbits/sec)

Interoperability test kit (ITK Revision) ITK 5.0, LAS capable

LAS capable Yes, Device type: Basic

DEV Revision 0X01

Available Blocks AI_1, PID_1, RB_1, TB_1

Polarity Sensitive No

Damping Adjustable 0-45 seconds

Block Execution Time 15 msec

Power (Measured at instrument terminals)

Fieldbus General Purpose/Explosion Proof 9 to 32 VDC \equiv (17 mA maximum current draw)

This device provides only Functional Isolation

IS/FISCO/FNICO 9 to 32 VDC \equiv (17 mA maximum current draw)

This device provides only Functional Isolation

Housing

Material Aluminum A356T6 (<0.20% copper), optional 316 stainless steel

Cable Entry ¾" NPT and M20

Ingress Protection TYPE 4X, IP66

Chamber

Materials Carbon steel

316/316L stainless steel

Wetted parts 316/316L and Inconel® (spring)

Process connections Tank Top: 3", 4", 6" ANSI Flange

Chambered: 1½", 2" NPT

1½", 2" Socketweld

1½", 2" ANSI Flanges

Process Conditions

Process temperature range ①	Steam applications: -20° to +500° F (-29° to +260° C)
	Non-steam applications: -20° to +600° F (-29° to +315° C) ②
Process pressure range	5150 psig @ +100° F (355 bar @ +38° C)

Environment

Electronics Operating Temperature	-40 to +176° F (-40 to +80° C)
Display Function Operating Temperature	-5 to +160° F (-20 to +70° C)
Storage Temperature	-50 to +185° F (-40 to +85° C)
Humidity	0-99%, non-condensing
Electromagnetic Compatibility	Meets CE Requirements: EN 61326
Shock Class	ANSI/ISA-S71.03 Class SA1 ③
Vibration Class	ANSI/ISA-S71.03 Class VC2 ③
Altitude	≤2000 m
Pollution Degree	2

8.6.2 Performance - Level

Linearity	±0.50% of full span
Repeatability	±0.05% of full span
Ambient temperature effect	Maximum zero shift is 0.017%/°F over ambient temperature range
Operating Temp. range:	-40° to +176° F (-40° to +80° C)
LCD Temp. Range:	-5° to +160° F (-20° to +70° C)
Hysteresis	±0.05% of full span
Response Time	<1 second
Warm-up Time	<5 seconds

8.6.3 Performance - Interface Level & Density

Linearity	±0.70% of full span
Repeatability	±0.10% of full span
Ambient temperature effect	Maximum zero shift is 0.017%/°F over ambient temperature range

- ① Maximum process temperatures are based on ambient temperatures less than or equal to +120° F (+49° C). Higher ambient temperatures require reduced process temperatures.
- ② Consult factory for low temperature applications down to -330° F (-200° C).
- ③ With aluminum housing only. Does not apply to models with 316 SS transmitter housings.

8.6.4 Physical – Inches (mm)

Dimensional specifications for standard pressure models E3A, E3B, E3C, E3D, E3E, E3F

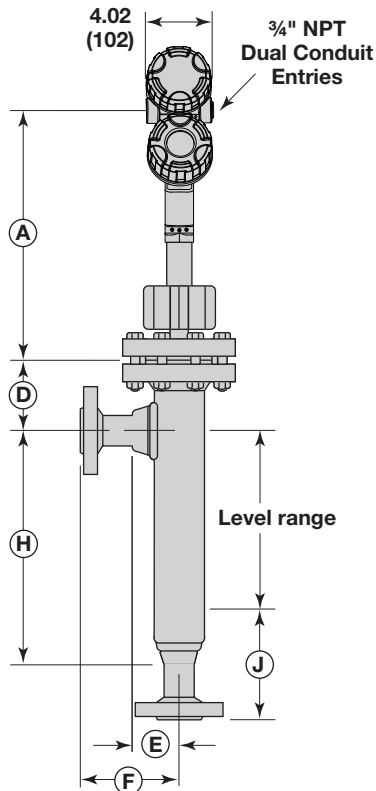

Figure 21

HT Integral Side/Bottom Mount
Fourth Digit Codes A, B, C

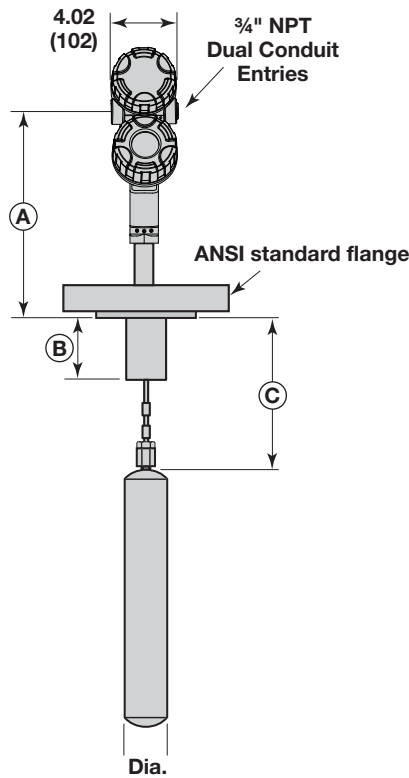

Figure 22

E3A/E3B Series with Integral Top Mounting
Fourth Digit Codes J, K, L

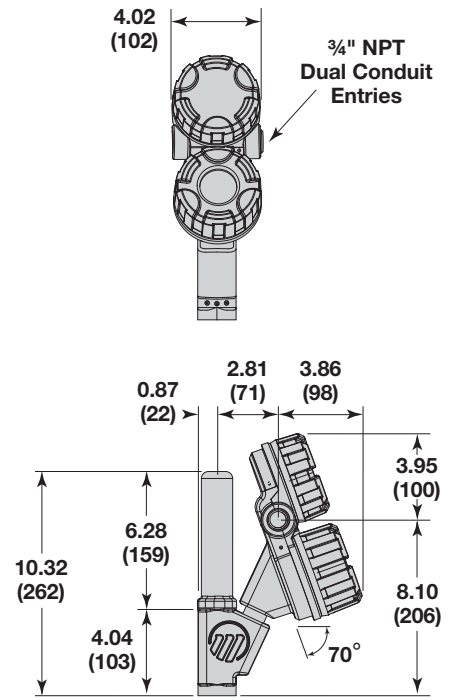

Figure 23

Integral Transmitter Head

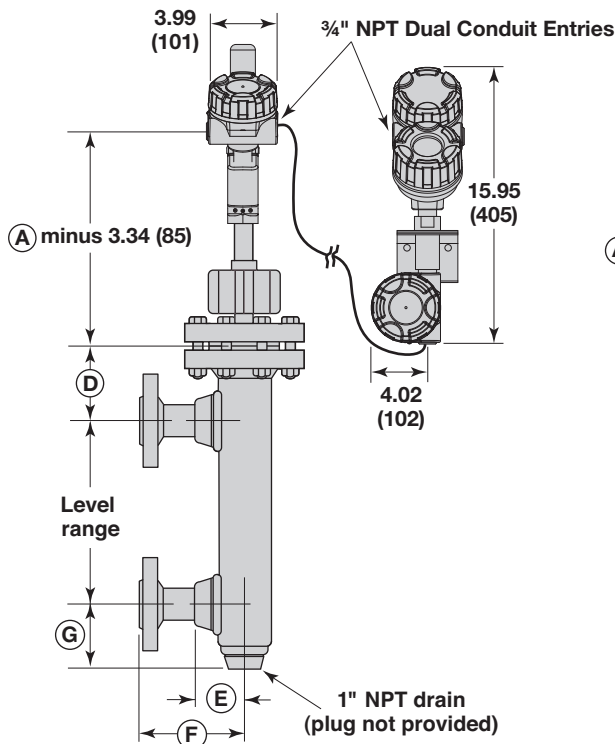
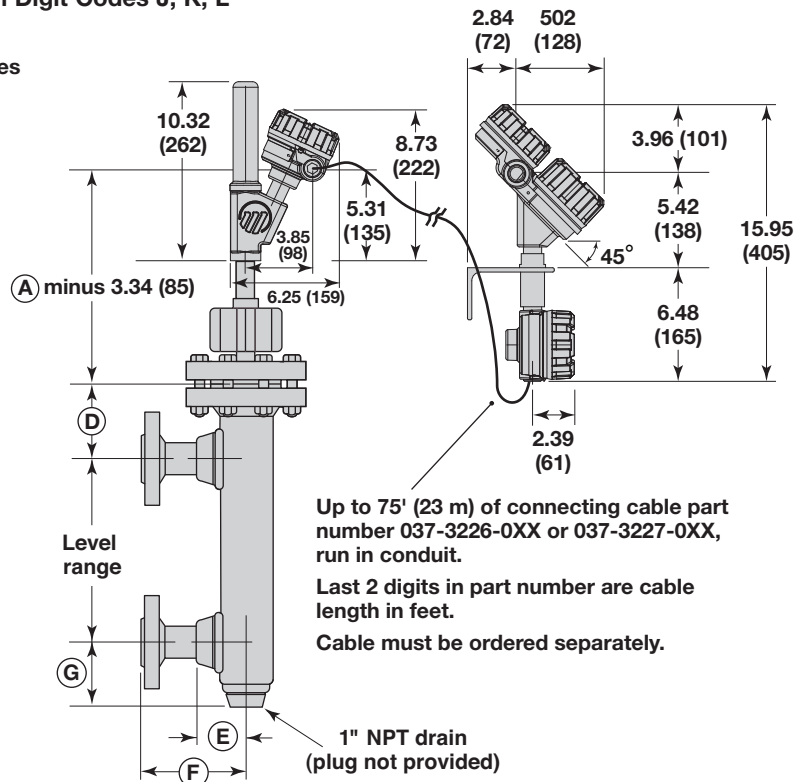

Figure 24

Remote Side/Side Mount
Fourth Digit Codes A, B, C



Up to 75' (23 m) of connecting cable part number 037-3226-0XX or 037-3227-0XX, run in conduit.
Last 2 digits in part number are cable length in feet.
Cable must be ordered separately.

Figure 25

Remote Side/Side Mount
Fourth Digit Codes A, B, C

Dimensional specifications – inches (mm)

Cage Pressure Rating	Process Conn. Size	Spring S.G. Range	Dimension							
			B	C	D	E	F	G	H	J
150#, 300# & 600# ANSI	1½"	0.23 – 0.54	6.75 (171)	9.31 (236)	9.31 (236)	3.19 (81)	7.00 (178)	3.00 (76)	3.00 + range (76 + range)	5.43 (138)
		0.55 – 1.09	4.75 (121)	7.31 (186)	7.31 (186)	3.19 (81)	7.00 (178)	3.00 (76)	3.00 + range (76 + range)	5.43 (138)
		1.10 – 2.20	4.75 (121)	7.31 (186)	7.31 (186)	3.19 (81)	7.00 (178)	3.00 (76)	3.00 + range (76 + range)	5.43 (138)
	2"	0.23 – 0.54	6.75 (171)	9.31 (236)	9.31 (236)	3.31 (84)	7.13 (181)	3.00 (76)	3.00 + range (76 + range)	5.43 (138)
		0.55 – 1.09	4.75 (121)	7.31 (186)	7.31 (186)	3.31 (84)	7.13 (181)	3.00 (76)	3.00 + range (76 + range)	5.43 (138)
		1.10 – 2.20	4.75 (121)	7.31 (186)	7.31 (186)	3.31 (84)	7.13 (181)	3.00 (76)	3.00 + range (76 + range)	5.43 (138)
900# ANSI	1½"	0.55 – 1.09	6.75 (171)	9.31 (236)	9.31 (236)	3.19 (81)	7.00 (178)	3.00 (76)	3.00 + range (76 + range)	5.43 (138)
	2"	0.55 – 1.09	6.75 (171)	9.31 (236)	9.31 (236)	3.31 (84)	7.13 (181)	3.00 (76)	3.00 + range (76 + range)	5.43 (138)
1500# ANSI	1½"	0.55 – 1.09	6.75 (171)	9.31 (236)	9.31 (236)	4.00 (102)	7.87 (200)	3.44 (87)	3.44 + range (87 + range)	9.08 (231)
	2"	0.55 – 1.09	6.75 (171)	9.31 (236)	9.31 (236)	4.38 (111)	8.81 (224)	3.44 (87)	3.44 + range (87 + range)	10.08 (256)
2500# ANSI	1½"	0.55 – 1.09	6.75 (171)	9.31 (236)	9.31 (236)	4.00 (102)	9.00 (229)	3.44 (87)	3.44 + range (87 + range)	10.21 (259)
	2"	0.55 – 1.09	6.75 (171)	9.31 (236)	9.31 (236)	4.38 (111)	9.81 (249)	3.44 (87)	3.44 + range (87 + range)	11.08 (281)

"A" Dimension		Fourth Digit of Model Number			
Cage Press. Rating	Head Flange Size	A, B, C	D, E, F	J, K, L	M, N, P
150# ANSI	3"	16.97 (431)	24.97 (634)	12.97 (329)	20.97 (533)
	4"	16.97 (431)	24.97 (634)	12.97 (329)	20.97 (533)
	6"	17.03 (433)	25.03 (636)	13.03 (331)	21.03 (534)
300# ANSI	3"	17.16 (436)	25.16 (639)	13.16 (334)	21.16 (537)
	4"	17.28 (439)	25.28 (642)	13.28 (337)	21.28 (541)
	6"	17.47 (444)	25.47 (647)	13.47 (342)	21.47 (545)
600# ANSI	3"	17.53 (445)	25.53 (648)	13.53 (344)	21.53 (547)
	4"	17.78 (452)	25.78 (655)	13.78 (350)	21.78 (553)
	6"	18.16 (461)	26.16 (664)	14.16 (360)	22.16 (563)
900# ANSI	3"	17.78 (452)	25.78 (655)	13.78 (350)	21.78 (553)
	4"	18.03 (458)	26.03 (661)	14.03 (356)	22.03 (560)
	6"	18.47 (469)	26.47 (672)	14.47 (368)	22.47 (571)
1500# ANSI	4"	18.41 (468)	26.41 (671)	14.41 (366)	22.41 (569)
	6"	19.53 (496)	27.53 (699)	15.53 (394)	23.53 (598)
2500# ANSI	4"	19.28 (490)	27.28 (693)	15.28 (388)	23.28 (591)
	6"	20.53 (521)	28.53 (725)	16.53 (420)	24.53 (623)

8.7 Model Numbers

8.7.1 E3x for Non-Steam Service

DESIGN TYPE

E 3	Standard Construction Electronic Modulelevel
------------	--

MOUNTING AND CHAMBER MATERIALS

Flanged top ①		Cage side/bottom		Cage side/side	
steel	316 SS	steel	316 SS ②	steel	316 SS ②
A	B	C	D	E	F

① Adjustable 8-foot hanger cable, part number 32-3110-001, required when distance from flange face to top of displacer must be greater than 7.31".

② Bolting material is alloy steel.

SPECIFIC GRAVITY AND PROCESS TEMPERATURE

Integral or Remote					Transmitter Mounting
1 & 4	1 & 4	1 & 4	1 & 4	3 & 6	Use with Mounting/Temp. codes (9th Digit)
+300° F (+150° C)	+400° F (+200° C)	+450° F (+230° C)	+550° F (+290° C)	+600° F (+315° C)	maximum process temperature
J	A	M	D	M	0.23 – 0.54 specific gravity (up to 600 lbs)
K	B	N	E	N	0.55 – 1.09 specific gravity (all pressures)
L	C	P	F	P	1.10 – 2.20 specific gravity (up to 600 lbs)

PROCESS CONNECTION SIZE & TYPE

External Cage		Top Mount			Type
1½"	2"	3"	4"	6"	
A	E	n/a	n/a	n/a	NPT
R	F	n/a	n/a	n/a	SW
P	Q	G	H	K	Flange

CHAMBER PRESSURE CLASS

ANSI Flange rating					
150# RF	300# RF	600# RF	900# RF	1500# RF	2500# RF ③
3	4	5	6	7	8

③ Pressure rating limited by enclosing tube to 5150 psi @ +100° F (355 bar @ +38° C)

LEVEL RANGE

All Pressures				600# or below					
14	32	48	60	72	84	96	108	120	Inches
356	813	1219	1524	1829	2134	2438	2743	3048	mm
A	B	C	D	E	F	G	H	I	Code

TRANSMITTER – ELECTRONICS (see opposite page)



8.7.1 E3x for Non-Steam Service - Transmitter Electronics

OUTPUT/SIL RATING

F	FOUNDATION fieldbus
----------	---------------------

MOUNTING/TEMPERATURE

Integral Mount		
	Maximum Process Temperature	Use with Specific Gravity and Process Temperature codes (4th Digit):
1	+550° F (+290° C)	J, K, L, A, B, C, M, N, P, D, E, F
3	+551° to +600° F (+291° to +315° C)	M, N, P
Remote Mount (FM & CSA only)		
	Maximum Process Temperature	Use with Specific Gravity and Process Temperature codes:
4	+550° F (+290° C)	J, K, L, A, B, C, M, N, P, D, E, F
6	+551° to +600° F (+291° to +315° C)	M, N, P

HOUSING MATERIAL/CONDUIT ENTRY/APPROVAL

Housing Material/Conduit Entry/Approval	9th Digit
1 Cast Aluminum, FM/CSA XP, 3/4" NPT	1,3,4,6
2 Cast Aluminum, FM XP, M20	1,3,4,6
3 Cast Stainless Steel, FM/CSA XP, 3/4" NPT	1,3,4,6
4 Cast Stainless Steel, FM XP, M20	1,3,4,6
5 Cast Aluminum, FM/CSA IS, 3/4" NPT	1,3,4,6
6 Cast Aluminum, FM IS, M20	1,3,4,6
7 Cast Stainless Steel, FM/CSA IS, 3/4" NPT	1,3,4,6
8 Cast Stainless Steel, FM IS, M20	1,3,4,6
A Cast Aluminum, ATEX/IEC IS, 3/4" NPT	1,3
B Cast Aluminum, ATEX/IEC IS, M20	1,3
C Cast Stainless Steel, ATEX/IEC IS, 3/4" NPT	1,3
D Cast Stainless Steel, ATEX/IEC IS, M20	1,3
E Cast Aluminum, ATEX XP, 3/4" NPT	1,3
F Cast Aluminum, ATEX XP, M20	1,3
G Cast Stainless Steel, ATEX XP, 3/4" NPT	1,3
H Cast Stainless Steel, ATEX XP, M20	1,3

E3X-XXXX (see previous page)



8.7.2 E3x for Steam Service

DESIGN TYPE

E 3	Standard Construction Electronic Modulelevel
------------	--

MOUNTING AND CHAMBER MATERIALS

Flanged top ①		Cage side/bottom		Cage side/side	
steel	316 SS	steel	316 SS ②	steel	316 SS ②
A	B	C	D	E	F

① Adjustable 8-foot hanger cable, part number 32-3110-001, required when distance from flange face to top of displacer must be greater than 7.31".

② Bolting material is alloy steel.

SPECIFIC GRAVITY AND PROCESS TEMPERATURE

Integral or Remote	Remote	Integral or Remote	Remote	Transmitter Mounting	
1 & 4	2 & 5	5	2 & 5	3 & 6	6
+300° F (+150° C)	+400° F (+200° C)	+400° F (+200° C)	+450° F (+230° C)	+500° F (+260° C)	+500° F (+260° C)
K	B	K	N	E	N
Use with Mounting/Temp. codes (9th Digit)					
maximum process temperature					
0.55 - 1.09 specific gravity (all pressures)					

PROCESS CONNECTION SIZE & TYPE

External Cage		Top Mount			Type
1½"	2"	3"	4"	6"	
A	E	n/a	n/a	n/a	NPT
R	F	n/a	n/a	n/a	SW
P	Q	G	H	K	Flange

CHAMBER PRESSURE CLASS

ANSI Flange rating					
150# RF	300# RF	600# RF	900# RF	1500# RF	2500# RF ③
3	4	5	6	7	8

③ Pressure rating limited by enclosing tube to 5150 psi @ 100° F (355 bar @ 38° C)

LEVEL RANGE

All Pressures				600# or below					
14	32	48	60	72	84	96	108	120	Inches
356	813	1219	1524	1829	2134	2438	2743	3048	mm
A	B	C	D	E	F	G	H	I	Code

TRANSMITTER – ELECTRONICS (see opposite page)



8.7.2 E3x for Steam Service - Transmitter Electronics

OUTPUT/SIL RATING

F	FOUNDATION fieldbus
----------	---------------------

MOUNTING/TEMPERATURE

Integral Mount		
	Maximum Process Temperature	Use with Specific Gravity and Process Temperature codes (4th Digit):
1	+300° F (+150° C)	K
2	+301° to +450° F (+151° to +230° C)	B, N
3	+451° to +500° F (+231° to +260° C)	E
Remote Mount (FM & CSA only)		
	Maximum Process Temperature	Use with Specific Gravity and Process Temperature codes (4th Digit):
4	+300° F (+150° C)	K
5	+301° to +450° F (+151° to +230° C)	B, K, N
6	+451° to +500° F (+231° to +260° C)	E, N

HOUSING MATERIAL/CONDUIT ENTRY/APPROVAL

	Housing Material/Conduit Entry/Approval	9th Digit
1	Cast Aluminum, FM/CSA XP, 3/4" NPT	1,2,3,4,5,6
2	Cast Aluminum, FM XP, M20	1,2,3,4,5,6
3	Cast Stainless Steel, FM/CSA XP, 3/4" NPT	1,2,3,4,5,6
4	Cast Stainless Steel, FM XP, M20	1,2,3,4,5,6
5	Cast Aluminum, FM/CSA IS, 3/4" NPT	1,2,3,4,5,6
6	Cast Aluminum, FM IS, M20	1,2,3,4,5,6
7	Cast Stainless Steel, FM/CSA IS, 3/4" NPT	1,2,3,4,5,6
8	Cast Stainless Steel, FM IS, M20	1,2,3,4,5,6
A	Cast Aluminum, ATEX/IEC IS, 3/4" NPT	1,2,3
B	Cast Aluminum, ATEX/IEC IS, M20	1,2,3
C	Cast Stainless Steel, ATEX/IEC IS, 3/4" NPT	1,2,3
D	Cast Stainless Steel, ATEX/IEC IS, M20	1,2,3
E	Cast Aluminum, ATEX XP, 3/4" NPT	1,2,3
F	Cast Aluminum, ATEX XP, M20	1,2,3
G	Cast Stainless Steel, ATEX XP, 3/4" NPT	1,2,3
H	Cast Stainless Steel, ATEX XP, M20	1,2,3

E3X-XXXX (see previous page)



8.8 References

1. FOUNDATION fieldbus™, A Pocket Guide
Ian Verhappen, Augusto Pereira
2. FOUNDATION fieldbus™—System Engineering Guidelines, AG–181

Appendix – Transducer Block Parameters

ITEM	PARAMETER NAME	PARAMETER LABEL
0	BLOCK_STRUCTURE	BLOCK STRUCT
1	ST_REV	ST REV
2	TAG_DESC	TAG DESC
3	STRATEGY	STRATEGY
4	ALERT_KEY	ALERT KEY
5	MODE_BLK	MODE BLK
6	BLOCK_ERR	BLOCK ERR
7	UPDATE_EVT	UPDATE EVT
8	BLOCK_ALM	BLOCK ALM
9	TRANSDUCER_DIRECTORY	XD DIRECTORY
10	TRANSDUCER_TYPE	XD TYPE
11	XD_ERROR	XD ERROR
12	COLLECTION_DIRECTORY	COLLECT DIR
13	MEASUREMENT_TYPE	Measurement Type
14	PRIMARY_VALUE	Primary Value
15	PRIMARY_VALUE_UNIT	Primary Value Unit
16	LVDT_DAMPING	LVDT Damping
17	PROCESS_SG	Process SG
18	PROCESS_TEMPERTURE	Process Temperature
19	LEVEL_OFFSET	Level Offset
20	TRIM_LEVEL	Trim Level
21	MODEL_NUMBER	Model Number
22	LEVEL_UNIT	Level Unit
23	DISPLACER_LENGTH	Displacer Length
24	DIAMETER_UNIT	Diameter Unit
25	DISPLACER_DIAMETER	Displacer Diameter
26	WEIGHT_UNIT	Weight Unit
27	DISPLACER_WEIGHT	Displacer Weight
28	SPRING_SG	Spring SG
29	SPRING_RATE	Spring Rate
30	SPRING_MATERIAL	Spring Material
31	PROCESS_TEMP_LIMIT	Process Temp Limit
32	LOWER_SG	Lower SG
33	UPPER_SG	Upper SG
34	SPECIFIC_GRAVITY_UNIT	SG Unit
35	TRIM_SG	Trim SG
36	ENTER_PASSWORD	Enter Password
37	NEW_PASSWORD	New User Password
38	DEVICE_STATUS	Device Status
39	HISTORY_STATUS	History Message

ITEM	PARAMETER NAME	PARAMETER LABEL
40	HISTORY_CONTROL	History Control
41	RESET_HISTORY	Reset History
42	CALIBRATION_SELECT	Calibration Select
43	LVDT_OUTPUT	LVDT%
44	SENSOR_UNIT	Sensor Unit
45	FACTORY_CALIBRATION_SG	Factory Calibration SG
46	FACTORY_DRY_SENSOR	Factory Dry Sensor
47	FACTORY_SENSOR_CAL_LO	Factory Sensor Cal Lo
48	FACTROY_SENSOR_CAL_HI	Factory Sensor Cal Hi
49	FACTORY_LEVEL_CAL_LO	Factory Level Cal Lo
50	FACTORY_LEVEL_CAL_HI	Factory Level Cal Hi
51	FACTORY_SG_CAL_LO	Factory SG Cal Lo
52	FACTORY_SG_CAL_HI	Factory SG Cal Hi
53	USER_DRY_SENSOR	User Dry Sensor
54	USER_SENSOR_CAL_LO	User Sensor Cal Lo
55	USER_SENSOR_CAL_HI	User Sensor Cal Hi
56	USER_LEVEL_CAL_LO	User Sensor Cal Lo
57	USER_LEVEL_CAL_HI	User Level Cal Hi
58	USER_SG_CAL_LO	User SG Cal Lo
59	USER_SG_CAL_HI	User SG Cal Hi
60	ADJUSTED_SENSOR_LO	Adjusted Sensor Lo
61	ADJUSTED_SENSOR_HI	Adjusted Sensor Hi
62	CONVERSION_FACTOR	Conversion Factor
63	SCALE_OFFSET	Scale Offset
64	LVDT_CHANNEL_0	LVDT Channel 0
65	LVDT_CHANNEL_1	LVDT Channel 1
66	TEMPERATURE_UNIT	Temperature Unit
67	ELECTRONICS_TEMPERATURE	Elec Temperature
68	MAX_ELECTRONICS_TEMPERATURE	Max Temperature
69	MIN_ELECTRONICS_TEMPERATURE	Min Temperature
70	RESET_ELECTRONICS_TEMPERATURE	Reset Temperatures
71	LCD_LANGUAGE	LCD Language
72	NSP_VALUE	NSP Value
73	FACTORY_PARAM_1	Factory Param 1
74	FACTORY_PARAM_2	Factory Param 2
75	NON_VOL_STAT	Non Vol Stat
76	DATE_CODE	Date Code
77	MAGNETROL_SERIAL_NUMBER	Magnetrol S/N
78	FIRMWARE_VERSION	Firmware Version



E3 Modulevel Displacer Level Transmitter

FOUNDATION Fieldbus™ Configuration Data Sheet

Copy blank page and store calibration data for future reference and troubleshooting.

Item	Value	Value	Value	TROUBLESHOOTING	
				Working Value	Non-Working Value
Vessel Name					
Vessel #					
Process Medium					
Tag #					
Serial #					
Model #					
Meas Type					
Level Units					
Process SG					
Process Temperature					
Level Offset					
LVDT Damping					
Trim Level					
Spring SG					
Spring Rate					
Spring Material					
Temperature Limit					
Displacer Length					
Displacer Diameter					
Displacer Weight					
CalSelect					
Conv Fct					
Scl Ofst					
Calib SG					
DrySensr					
SnrCalLo					
LvlCalLo (or SGCalLo)					
SnrCalHi					
LvlCalHi (orSGCalHi)					
Name					
Date					
Time					

Service Policy

Owners of Magnetrol may request the return of a control or any part of a control for complete rebuilding or replacement. They will be rebuilt or replaced promptly. Controls returned under our service policy must be returned by Prepaid transportation. Magnetrol will repair or replace the control at no cost to the purchaser (or owner) other than transportation if:

1. Returned within the warranty period; and
2. The factory inspection finds the cause of the claim to be covered under the warranty.

If the trouble is the result of conditions beyond our control; or, is NOT covered by the warranty, there will be charges for labor and the parts required to rebuild or replace the equipment.

In some cases it may be expedient to ship replacement parts; or, in extreme cases a complete new control, to replace the original equipment before it is returned. If this is desired, notify the factory of both the model and serial numbers of the control to be replaced. In such cases, credit for the materials returned will be determined on the basis of the applicability of our warranty.

No claims for misapplication, labor, direct or consequential damage will be allowed.

For Technical Support contact one of the offices listed below.

Return Material Procedure

So that we may efficiently process any materials that are returned, it is essential that a "Return Material Authorization" (RMA) number be obtained from the factory, prior to the material's return. This is available through Magnetrol local representative or by contacting the factory. Please supply the following information:

1. Company Name
2. Description of Material
3. Serial Number
4. Reason for Return
5. Application

Any unit that was used in a process must be properly cleaned in accordance with OSHA standards, before it is returned to the factory.

A Material Safety Data Sheet (MSDS) must accompany material that was used in any media.

All shipments returned to the factory must be by prepaid transportation.

All replacements will be shipped F.O.B. factory.

NOTE: See Electrostatic Discharge Handling Procedure on page 10.

NOTE: If unit needs to be returned, the displacer must be secured to prevent damage in transit.



5300 Belmont Road • Downers Grove, Illinois 60515-4499 • 630-969-4000 • Fax 630-969-9489 • www.magnetrol.com
 145 Jardin Drive, Units 1 & 2 • Concord, Ontario Canada L4K 1X7 • 905-738-9600 • Fax 905-738-1306
 Heikensstraat 6 • B 9240 Zele, Belgium • 052 45.11.11 • Fax 052 45.09.93
 Regent Business Ctr., Jubilee Rd. • Burgess Hill, Sussex RH15 9TL U.K. • 01444-871313 • Fax 01444-871317

Copyright © 2009 Magnetrol International, Incorporated. All rights reserved. Printed in the USA.

CSA logotype is a registered trademark of Canadian Standards Association
 HART® is a registered trademark of the HART Communication Foundation
 Inconel® is a registered trademark of Special Metals Corporation
 Teflon® is a registered trademark of DuPont.

BULLETIN: 48-640.1
EFFECTIVE: June 2009
SUPERSEDES: February 2009