

To all our customers

---

## **Regarding the change of names mentioned in the document, such as Hitachi Electric and Hitachi XX, to Renesas Technology Corp.**

---

The semiconductor operations of Mitsubishi Electric and Hitachi were transferred to Renesas Technology Corporation on April 1st 2003. These operations include microcomputer, logic, analog and discrete devices, and memory chips other than DRAMs (flash memory, SRAMs etc.) Accordingly, although Hitachi, Hitachi, Ltd., Hitachi Semiconductors, and other Hitachi brand names are mentioned in the document, these names have in fact all been changed to Renesas Technology Corp. Thank you for your understanding. Except for our corporate trademark, logo and corporate statement, no changes whatsoever have been made to the contents of the document, and these changes do not constitute any alteration to the contents of the document itself.

Renesas Technology Home Page: <http://www.renesas.com>

Renesas Technology Corp.  
Customer Support Dept.  
April 1, 2003

## Cautions

Keep safety first in your circuit designs!

1. Renesas Technology Corporation puts the maximum effort into making semiconductor products better and more reliable, but there is always the possibility that trouble may occur with them. Trouble with semiconductors may lead to personal injury, fire or property damage.

Remember to give due consideration to safety when making your circuit designs, with appropriate measures such as (i) placement of substitutive, auxiliary circuits, (ii) use of nonflammable material or (iii) prevention against any malfunction or mishap.

Notes regarding these materials

1. These materials are intended as a reference to assist our customers in the selection of the Renesas Technology Corporation product best suited to the customer's application; they do not convey any license under any intellectual property rights, or any other rights, belonging to Renesas Technology Corporation or a third party.
2. Renesas Technology Corporation assumes no responsibility for any damage, or infringement of any third-party's rights, originating in the use of any product data, diagrams, charts, programs, algorithms, or circuit application examples contained in these materials.
3. All information contained in these materials, including product data, diagrams, charts, programs and algorithms represents information on products at the time of publication of these materials, and are subject to change by Renesas Technology Corporation without notice due to product improvements or other reasons. It is therefore recommended that customers contact Renesas Technology Corporation or an authorized Renesas Technology Corporation product distributor for the latest product information before purchasing a product listed herein.  
The information described here may contain technical inaccuracies or typographical errors. Renesas Technology Corporation assumes no responsibility for any damage, liability, or other loss rising from these inaccuracies or errors.  
Please also pay attention to information published by Renesas Technology Corporation by various means, including the Renesas Technology Corporation Semiconductor home page (<http://www.renesas.com>).
4. When using any or all of the information contained in these materials, including product data, diagrams, charts, programs, and algorithms, please be sure to evaluate all information as a total system before making a final decision on the applicability of the information and products. Renesas Technology Corporation assumes no responsibility for any damage, liability or other loss resulting from the information contained herein.
5. Renesas Technology Corporation semiconductors are not designed or manufactured for use in a device or system that is used under circumstances in which human life is potentially at stake. Please contact Renesas Technology Corporation or an authorized Renesas Technology Corporation product distributor when considering the use of a product contained herein for any specific purposes, such as apparatus or systems for transportation, vehicular, medical, aerospace, nuclear, or undersea repeater use.
6. The prior written approval of Renesas Technology Corporation is necessary to reprint or reproduce in whole or in part these materials.
7. If these products or technologies are subject to the Japanese export control restrictions, they must be exported under a license from the Japanese government and cannot be imported into a country other than the approved destination.  
Any diversion or reexport contrary to the export control laws and regulations of Japan and/or the country of destination is prohibited.
8. Please contact Renesas Technology Corporation for further details on these materials or the products contained therein.

---

# HA12211NT

Audio Signal Processor for Cassette Deck (Deck 1 Chip)



ADE-207-223A (Z)

2nd. Edition  
June 1997

---

## Description

HA12211NT is silicon monolithic bipolar IC providing REC equalizer system, PB equalizer system and each electronic control switch in one chip.

## Functions

- PB equalizer × 2 channel
- REC equalizer × 2 channel
- Each electronic control switch to change equalizer characteristics
- REC mute
- REC head return switch

## Features

- REC equalizer is very small number of external parts.(4 types of frequency characteristics built-in)
- PB equalizer built-in. (A/B input changing system, 4 types of frequency characteristics)
- Independent PB sensitivity for A deck, B deck.
- Normal-speed/high-speed, normal tape/chrome tape switching built-in.
- Controllable from direct micro-computer output.
- Available to reduce substrate-area because of high integration and small external parts.

# HA12211NT

**Pin Description, Equivalent Circuit** ( $V_{cc} = 10.5V$ ,  $V_{ref} = 5.25V$ ,  $T_a = 25^\circ C$ , No signal, The value in the table show typical value.)

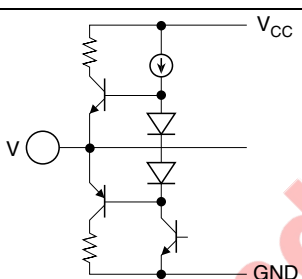
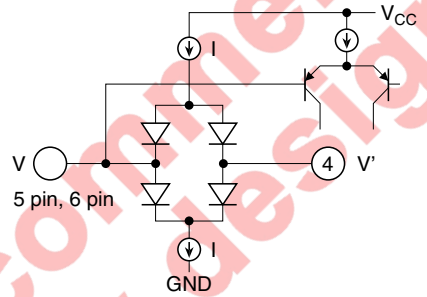
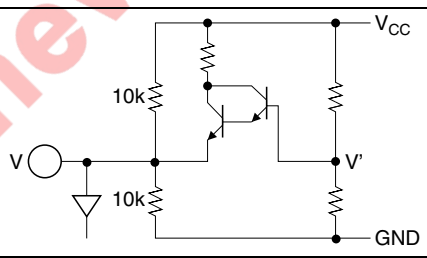
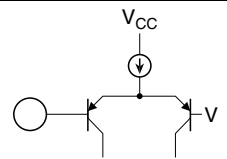
Pin No.	Pin Name	Note	Equivalent Circuit	Pin Description
1	$V_{cc}$	$V = V_{cc}$		$V_{cc}$ Pin
2	RECOUT (L)	$V = V_{ref}$		REC-EQ output
3	RECOUT (R)			
4	REC-RETURN	$V = V_{ref}$ $V' = V_{ref}$		REC Return
5	PB-IN B (L)			PB B Deck input
6	PB-IN B (R)			
7	VREF	$V = V_{ref}$ $V' = V_{cc} / 2$		Reference
8	PB-IN A(L)	$V = V_{ref}$		PB A Deck input
9	PB-IN A(R)			

**Pin Description, Equivalent Circuit** ( $V_{cc} = 10.5V$ ,  $V_{ref} = 5.25V$ ,  $T_a = 25^\circ C$ , No signal, The value in the table show typical value.) (cont)

Pin No.	Pin Name	Note	Equivalent Circuit	Pin Description
10	PB-NF (L)	$V = V_{ref}$		PB EQ Feed back
11	PB-NF (R)			
12	PB-EQ (L)	$V = V_{ref}$		NAB Output
13	PB-EQ (R)			
14	PB-Cal A(L)	$V = V_{ref}$		Feed back input for gain adjustment
15	PB-Cal A(R)			
16	PB-Cal B(R)			
17	PB-Cal B(L)			
26	AUX (R)	$V = V_{ref}$		REC-EQ input
27	AUX (L)			
28	TAPE (R)			
29	TAPE (L)			

# HA12211NT

**Pin Description, Equivalent Circuit** ( $V_{CC} = 10.5V$ ,  $V_{ref} = 5.25V$ ,  $T_a = 25^\circ C$ , No signal, The value in the table show typical value.) (cont)

Pin No.	Pin Name	Note	Equivalent Circuit	Pin Description
18	PBOUT (R)	$V = V_{ref}$		PB output
19	PBOUT (L)			
20	A/B	$I = 20\mu A$		Mode control input
21	HSP			
22	Acr			
23	Bcr			
24	REC-SEL	$I = 20\mu A$ $V = 2.5V$		Mode control input
25	IREF	$V = 1.2V$		Equalizer reference current input
30	GND			GND Pin



# HA12211NT

## Parallel Data Format

Pin No.	Pin Name	L	M	H
22	A CrO2	*1, *3	—	*1
23	B CrO2	*1, *2, *3	—	*1, *2
21	HSP	Normal speed *3	—	Hi speed
20	A/B	Ain active *1, *3	—	Bin active *1
		Return SW ON *3	—	Return SW OFF
		REC OUT active *3	—	REC OUT Hiz
24	REC IN SEL	TAPE	MUTE *3	AUX

Note: 1. PB-EQ LOGIC

		HSP			
		L		H	
		A/B			
A CrO2	B CrO2	L	H	L	H
L	L	120μ	120μ	60μ	60μ
L	H	120μ	70μ	60μ	35μ
H	L	70μ	120μ	35μ	60μ
H	H	70μ	70μ	35μ	35μ

2. REC-EQ LOGIC

		HSP	
B CrO2		L	H
L		Normal speed TAPE I	High speed TAPE I
H		Normal speed TAPE II	High speed TAPE II

3. Unforced pin state

**Functional Description**

**Power Supply Range**

This IC is designed to operate on single supply, shown by table 1.

**Table 1 Sply Voltage**

Item	Power Supply Range
Single Supply	9.5V to 15.0V

**Reference Voltage**

So little is the current drivability of AC reference (Vref) that the Vref voltage may be altered by A/B switching of PB-EQ.

Provided it causes you anxiety, please use the constant  $1/2 V_{CC}$  voltage circuit, for example, figure 1.

In addition, this IC has a capacitor charger for Vref pin.

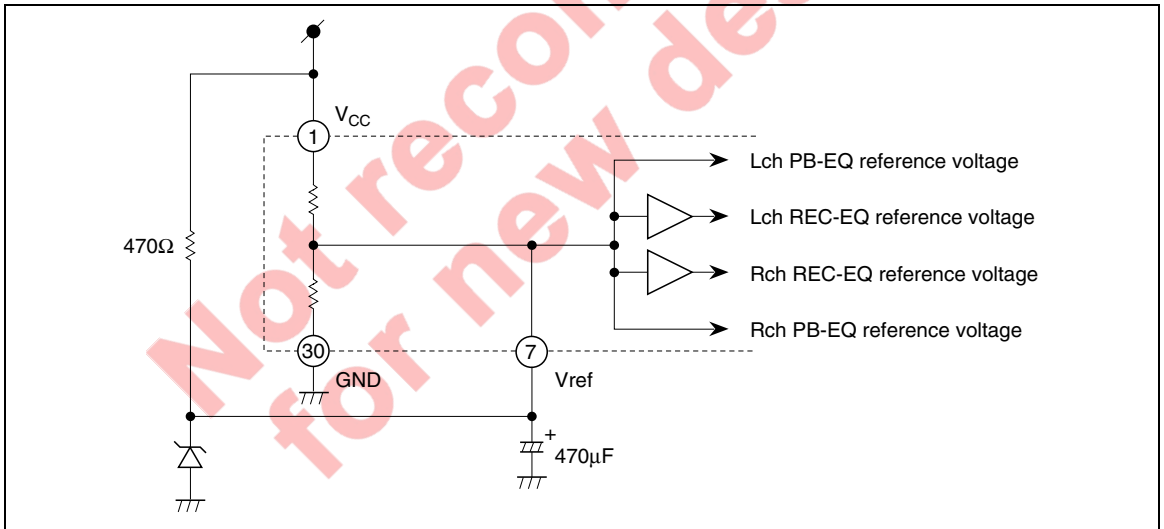

**Figure 1 Reference Voltage Circuit**

# HA12211NT

## Operating Mode Control

This IC provides fully electronic switching circuits. And each operating mode control is controlled by parallel data (DC voltage).

**Table 2 Threshold Voltage (Vth)**

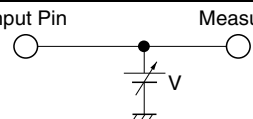
Pin No.	Lo	Mid	Hi	Unit	Test Condition
20, 21, 22, 23	0.0 to 2.5	—	4.0 to $V_{CC}$	V	Input Pin 
24	0.0 to 1.0	2.0 to 3.0	4.0 to $V_{CC}$	V	

- Note:
- 20 to 23 pins are pulled down Lo level, and 24 pin is pulled to Mid level by the inside resistor 100k $\Omega$ .
  - Over shoot level and under shoot level of input signal must be the standardized. (High:  $V_{CC}$ , Low: -0.2V)

## Block Diagram

This IC can be constructed for simple system which has little external parts by used the head serving both as Recording and Play back because of REC return SW built-in.

With output Hi-Z of REC-EQ and input muting, this IC is realized not only REC mute attenuation sufficiently but reducing pop noise in REC muting.

Note: Referring to Parallel Data Format also.

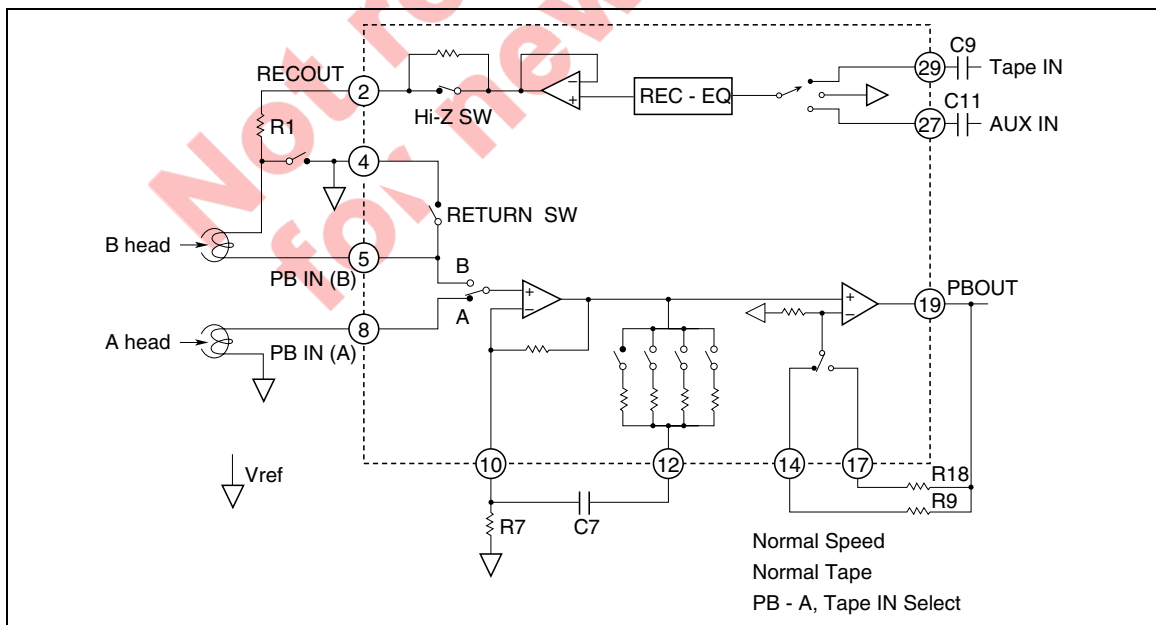

**Figure 2 Block Diagram (Lch)**

**Level Diagram**

It is the target that total play back output level is adjusted to 300mV; Dolby level, which the PB system gain in all is included of external amplifier's (Dolby IC etc.) as follows figure 3. Though A head adjustment is independent of B, select the value of R9, R18 adequately.

Regarding REC-EQ adjust the gain in front of input to this IC.

The level diagram at 1kHz is shown by figure 4.

- Note:
1. R1 needs the value more than 1kHz.
  2. Depending on the employed REC/PB head and test tape characteristics, there is rare case that the REC-EQ frequency characteristics of this IC can not be matched to the required characteristics because of built-in resistors which determined the REC-EQ parameters in this case, please inquire the responsible agent because of the adjustment of built-in resistors is necessary.

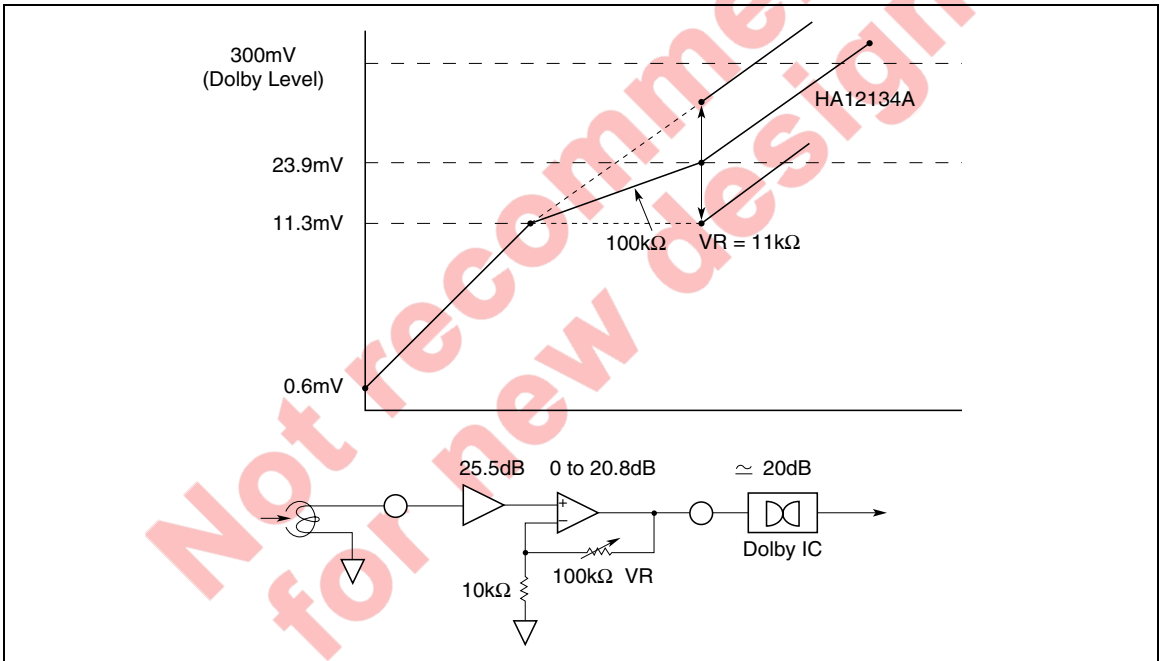

**Figure 3 PB Level Diagram (Normal Speed, Normal Tape, 1kHz)**

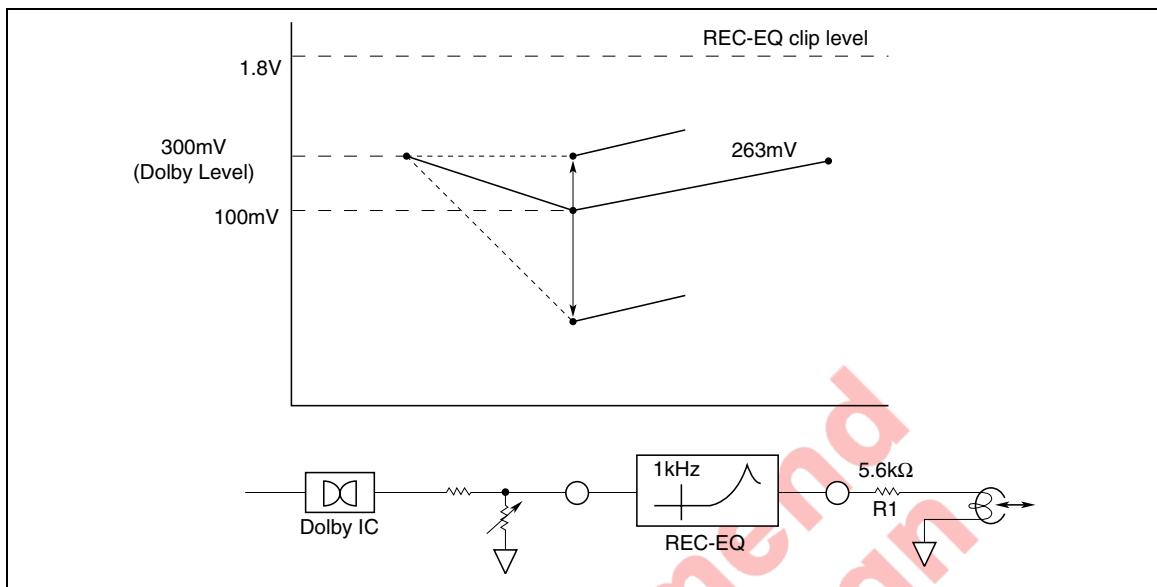

Figure 4 REC Level Diagram (Normal Speed, Normal Tape, 1kHz)

Not recommended for new designs

**Absolute Maximum Rating** ( $T_a = 25^\circ\text{C}$ )

Item	Symbol	Rating	Unit	Note
Max supply voltage	$V_{cc \text{ max}}$	16	V	
Power dissipation	$P_d$	500	mW	$T_a \leq 75^\circ\text{C}$
Operating temperature	$T_{opr}$	-40 to +75	$^\circ\text{C}$	
Storage temperature	$T_{stg}$	-55 to +125	$^\circ\text{C}$	
Operating voltage	$V_{opr}$	9.5 to 15	V	

Not recommend  
for new design

## Electrical Characteristics (Ta = 25°C, V<sub>CC</sub> = 10.5V, V<sub>ref</sub> = 5.25V, PB-EQ standard DC gain 55.9dB (R9, R10, R18, R19 = 11.0kΩ))

Item	Symbol	Min	Typ	Max	Unit	A/B	HSP	A CrO2 B CrO2 IN SEL	REC	f <sub>in</sub>	V <sub>in</sub>	Application Terminal						
												Mute	Other	Input	Output			
								TYPE I	TYPE I			R	L	R	L	COM		
Quiescent current	I <sub>Q</sub>	16.0	22.8	32.0	mA	A	Norm	TYPE I	TYPE I	—	—	No signal					1	
Logical threshold	V <sub>IL1</sub>	-0.2	—	2.5	V	—	—	—	—	—	—	—					20 to 23	
	V <sub>IL2</sub>	-0.2	—	1.0	V	—	—	—	—	—	—	—					24	
	V <sub>IM</sub>	2.0	—	3.0	V	—	—	—	—	—	—	—					24	
	V <sub>IH</sub>	4.0	—	V <sub>CC</sub>	V	—	—	—	—	—	—	—					20 to 24	
PB-REC Crosstalk	CT PB/REC(1)	50	60	—	dB	A/B	Norm	TYPE I	TYPE I	Tape/ 1k	*1		27/ 26/ 29	26/ 28	18	19		
	CT PB/REC(2)	60	70	—	dB	A	Norm	TYPE I	TYPE I	Tape/ 1k	*1		9	8	3	2		
PB-EQ Gain	G <sub>V</sub> PB (1)	29.0	32.0	35.0	dB	A/B	Norm	TYPE I	TYPE I	Tape 1k	0.6		9/6	8/5	18	19		
	G <sub>V</sub> PB (2)	25.0	28.0	31.0	dB	A/B	Norm	TYPE I	TYPE I	Tape 10k	0.6		9/6	8/5	18	19		
	G <sub>V</sub> PB (3)	20.8	23.8	26.8	dB	A/B	Norm	TYPE II	TYPE II	Tape 10k	0.6		9/6	8/5	18	19		
	G <sub>V</sub> PB (4)	19.4	22.4	25.4	dB	A/B	High	High	TYPE I	TYPE I	Tape 20k	0.6		9/6	8/5	18	19	
	G <sub>V</sub> PB (5)	14.8	17.8	20.8	dB	A/B	High	High	TYPE II	TYPE II	Tape 20k	0.6		9/6	8/5	18	19	
PB-EQ Maximum output	V <sub>omax</sub> PB	0.3	2.0	—	Vrms	A/B	Norm	TYPE I	TYPE I	Tape 1k	—	THD=1%*2	9/6	8/5	18	19		
PB-EQ THD	THD PB	—	0.1	0.5	%	A/B	Norm	TYPE I	TYPE I	Tape 1k	0.6		9/6	8/5	18	19		
PB-EQ Noise voltage	V <sub>N</sub> PB	—	38	70	μVrms	A/B	Norm	TYPE I	TYPE I	Tape 1k	—	Rg=820Ω, DIN-AUDIO	9/6	8/5	18	19		
PB-EQ Channel separation	CT R/L (1)	50	60	—	dB	A/B	Norm	TYPE I	TYPE I	Tape 1k	*1		8/5	9/6	18	19		
PB-EQ Crosstalk	CT A/B	60	70	—	dB	A	Norm	TYPE I	TYPE I	Tape 1k	*1		11	10	18	19		
						B							9	8				

Note: 1. Large level without clipping

2. V<sub>CC</sub> = 9.5V, V<sub>ref</sub> = 4.75V, R9, R10, R18, R19 = 56kΩ

Electrical Characteristics (Ta = 25°C, V<sub>cc</sub> = 10.5V, V<sub>ref</sub> = 5.25V, EQIN standard level = 100mV = 0dB) (cont)

Item	Symbol	Min	Typ	Max	Unit	A/B	HSP	A CrO2 B CrO2 IN SEL	REC fin	Vin	Application Terminal	
											Input	Output
											R	L
REC-EQ Frequency response Normal speed TYPE I	G <sub>v</sub> REC-NN 1	6.7	8.2	9.7	dB	A	Norm	TYPE I	Tape/ 1k	10	26/ 27/ 28	27/ 29
	G <sub>v</sub> REC-NN 2	9.3	11.3	13.3	dB	A	Norm	TYPE I	Tape/ 5k	10	26/ 27/ 28	27/ 29
	G <sub>v</sub> REC-NN 3	17.3	20.3	23.3	dB	A	Norm	TYPE I	Tape/ 10k	10	26/ 27/ 28	27/ 29
REC-EQ Frequency response Normal speed TYPE II	G <sub>v</sub> REC-NC 1	9.8	11.3	12.8	dB	A	Norm	TYPE II	Tape/ 1k	10	26/ 27/ 28	27/ 29
	G <sub>v</sub> REC-NC 2	14.2	16.2	18.2	dB	A	Norm	TYPE II	Tape/ 5k	10	26/ 27/ 28	27/ 29
	G <sub>v</sub> REC-NC 3	20.5	23.5	26.5	dB	A	Norm	TYPE II	Tape/ 10k	10	26/ 27/ 28	27/ 29
REC-EQ Frequency response High speed TYPE I	G <sub>v</sub> REC-HN 1	7.0	8.5	10.0	dB	A	High	TYPE I	Tape/ 2k	10	26/ 27/ 28	27/ 29
	G <sub>v</sub> REC-HN 2	10.9	12.9	14.9	dB	A	High	TYPE I	Tape/ 10k	10	26/ 27/ 28	27/ 29
	G <sub>v</sub> REC-HN 3	18.7	21.7	24.7	dB	A	High	TYPE I	Tape/ 20k	10	26/ 27/ 28	27/ 29
REC-EQ Frequency response High speed TYPE II	G <sub>v</sub> REC-HC 1	11.0	12.5	14.0	dB	A	High	TYPE II	Tape/ 2k	10	26/ 27/ 28	27/ 29
	G <sub>v</sub> REC-HC 2	16.2	18.2	20.2	dB	A	High	TYPE II	Tape/ 10k	10	26/ 27/ 28	27/ 29
	G <sub>v</sub> REC-HC 3	23.7	26.7	29.7	dB	A	High	TYPE II	Tape/ 20k	10	26/ 27/ 28	27/ 29
REC-EQ Channel separation	CT R/L (2)	50	60	—	dB	A	Norm	TYPE I	Tape/ 1k	*1	26/ 27/ 28	27/ 29
REC-EQ Crosstalk	CT Tape/AUX	50	60	—	dB	A	Norm	TYPE I	Tape/ 1k	*1	26/ 27/ 28	27/ 29
REC-EQ Attenuation	R-MUTE ATT	70	80	—	dB	A	Norm	TYPE I	Mute	1k	26/ 27/ 28	27/ 29
REC-EQ Maximum output	Vomax REC	1.2	1.8	—	Vrms	A	Norm	TYPE I	Tape/ 1k	—	26/ 27/ 28	27/ 29
REC-EQ THD	THD REC	—	0.35	0.7	%	A	Norm	TYPE I	Tape/ 1k	100	26/ 27/ 28	27/ 29
REC-EQ S/N	S/N REC	52	56	—	dB	A	Norm	TYPE I	Tape/ 1k	—	26/ 27/ 28	27/ 29

Note: 1. Large level without clipping  
 2. V<sub>cc</sub> = 9.5V, V<sub>ref</sub> = 4.75V

# HA12211NT

## Test Circuit

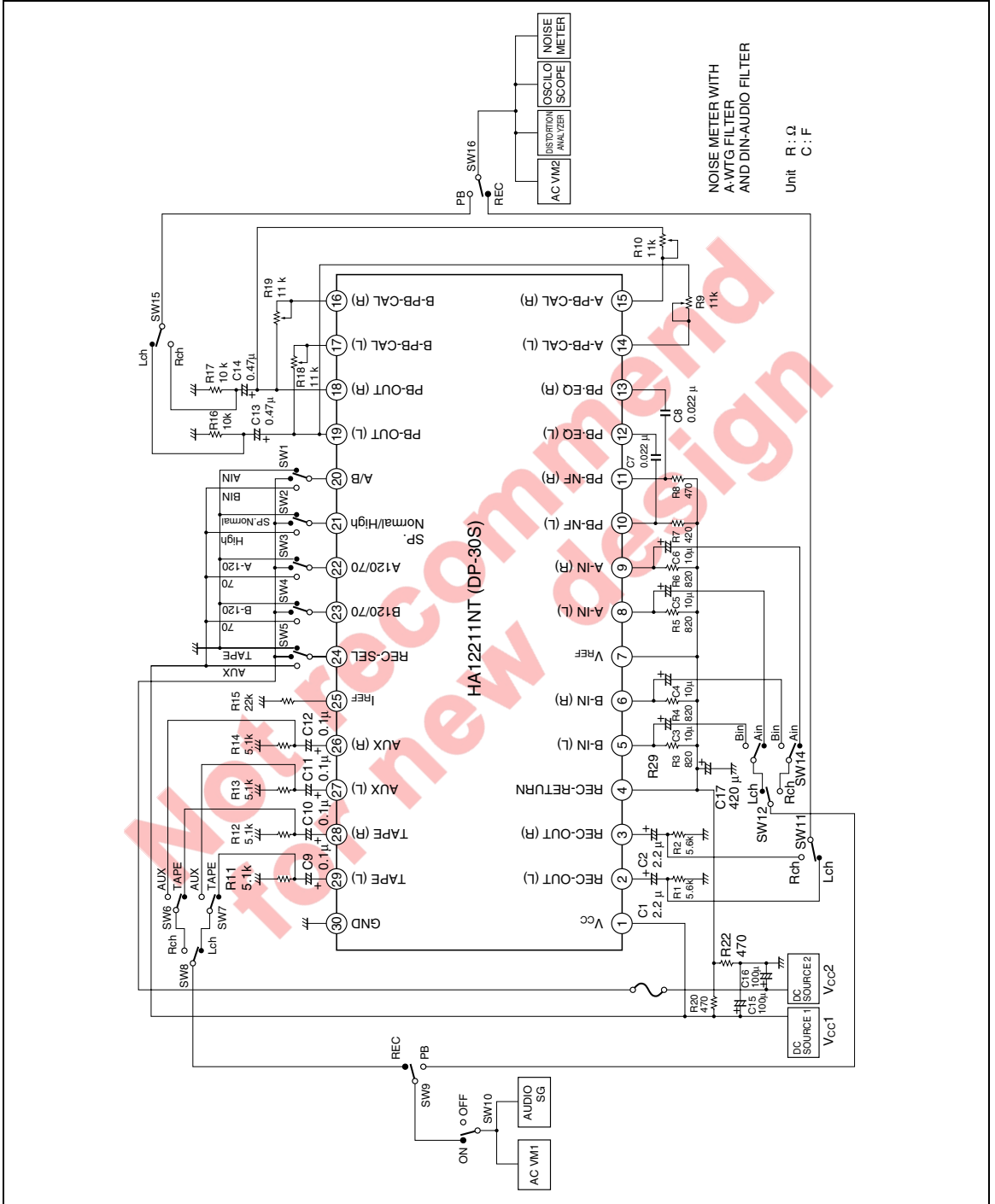

Characteristics Curve

Quiescent Current vs. Supply Voltage

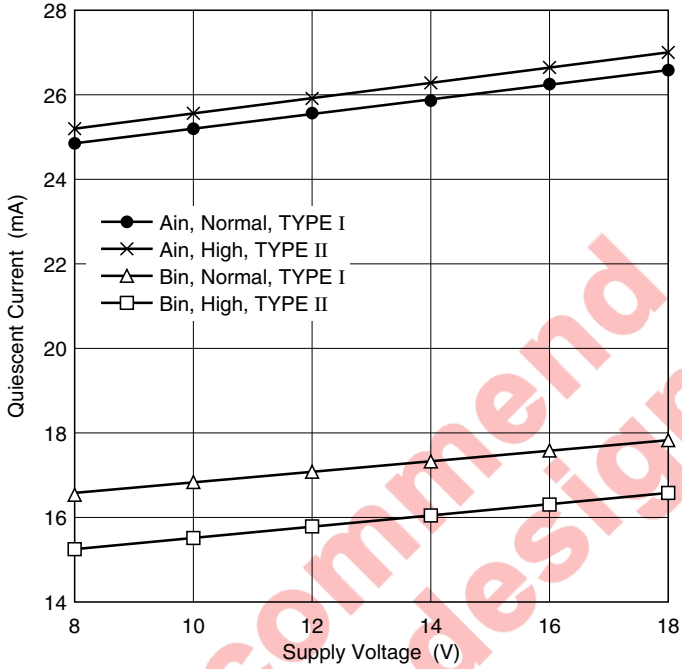

PB-EQ Gain vs. Frequency

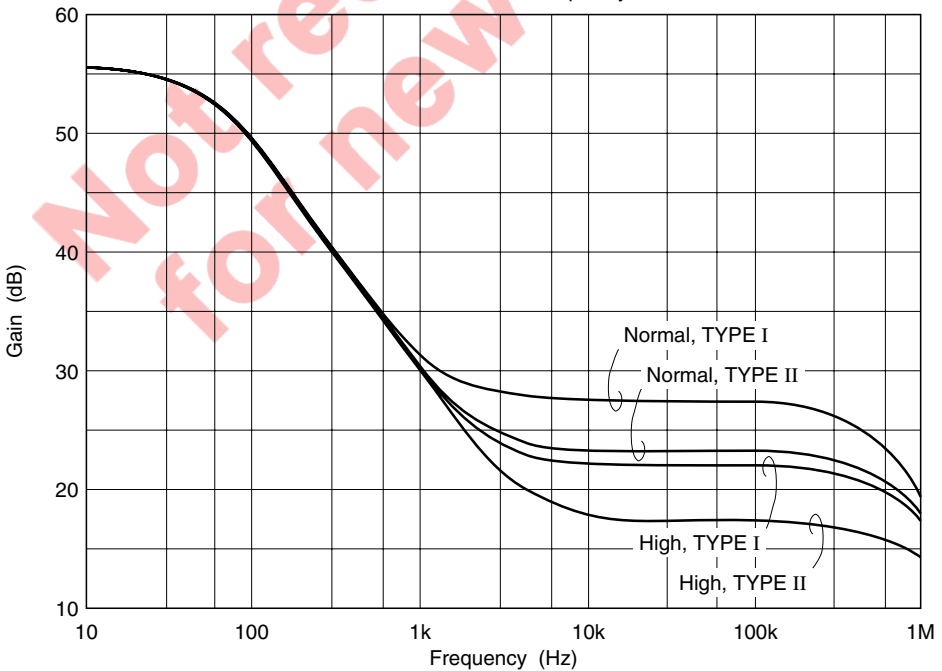

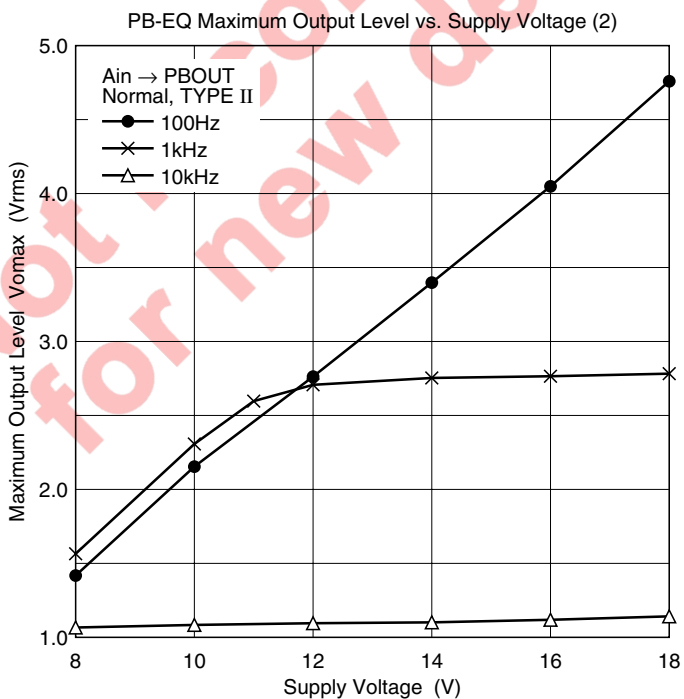
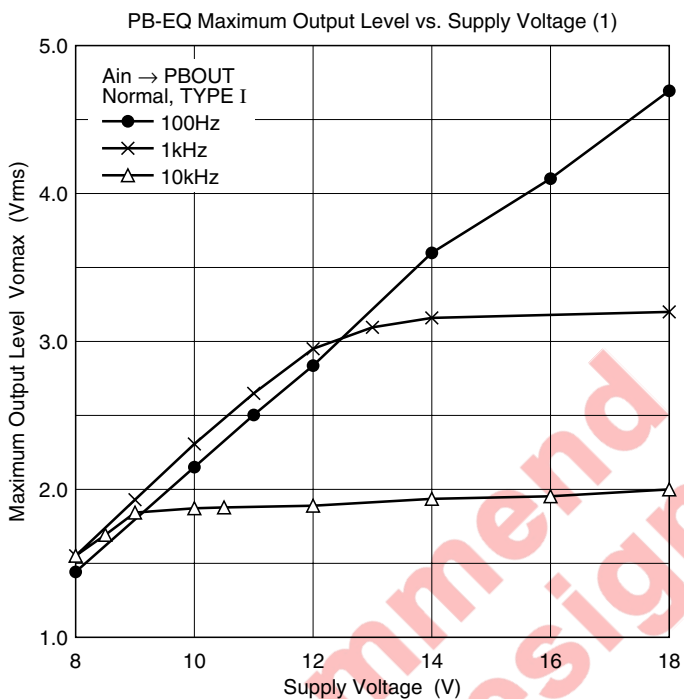

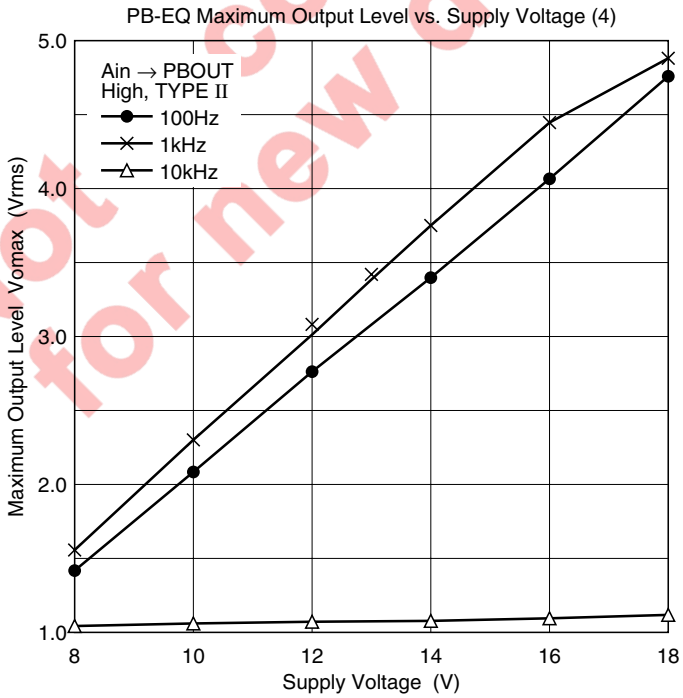
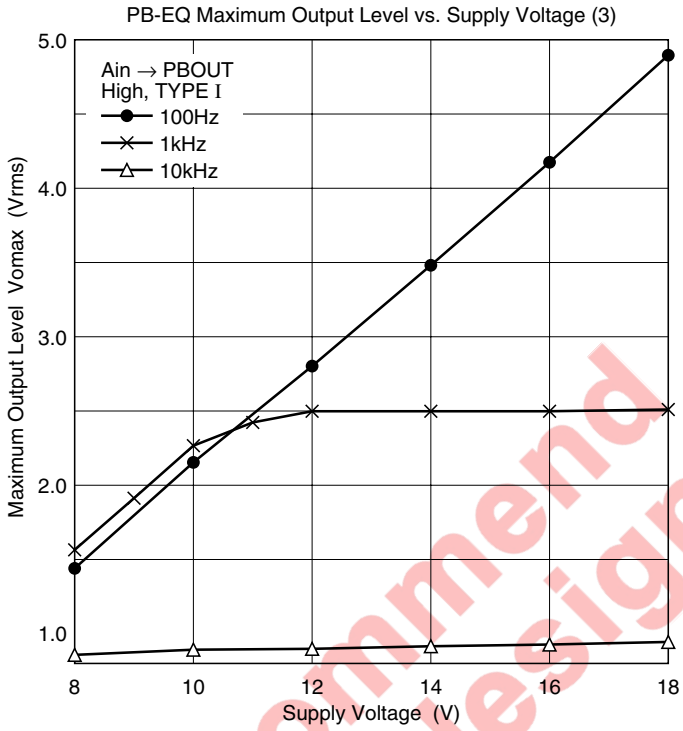

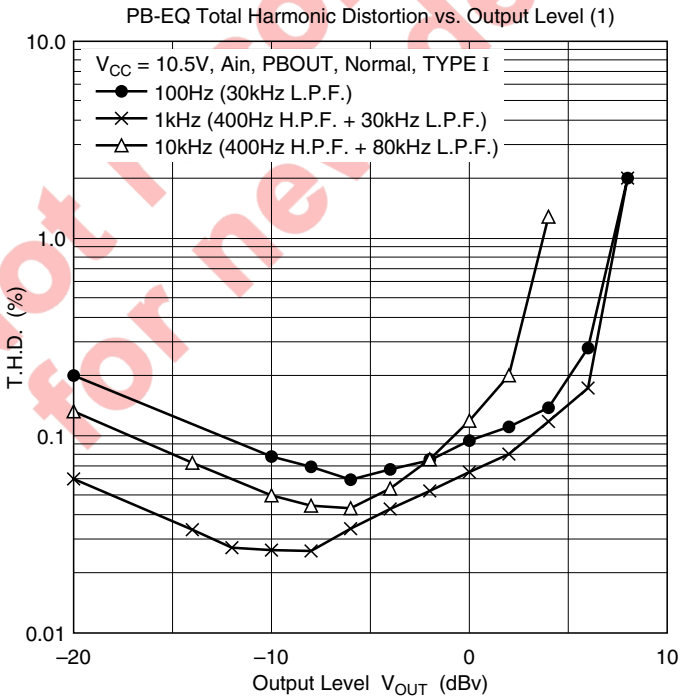
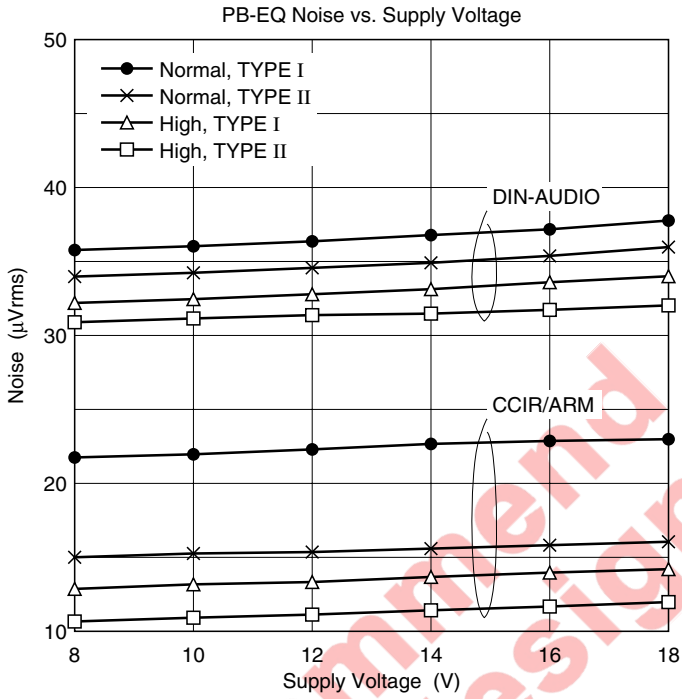

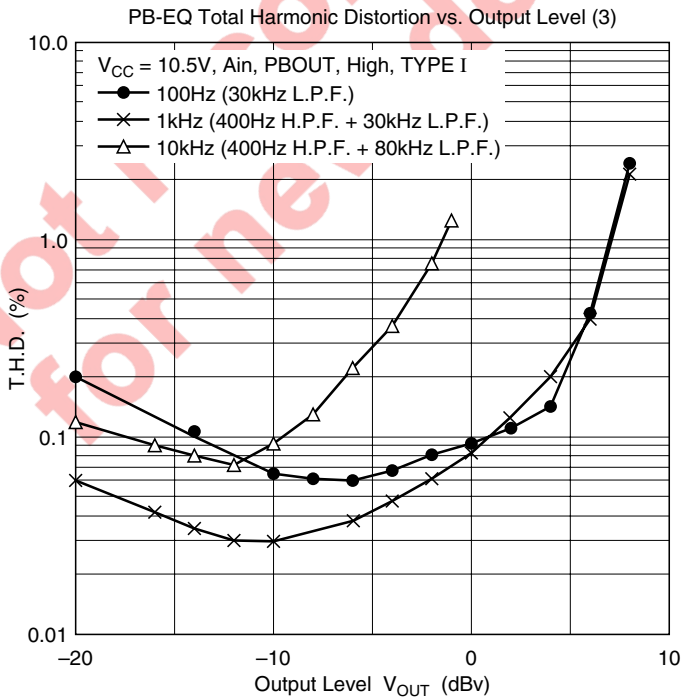
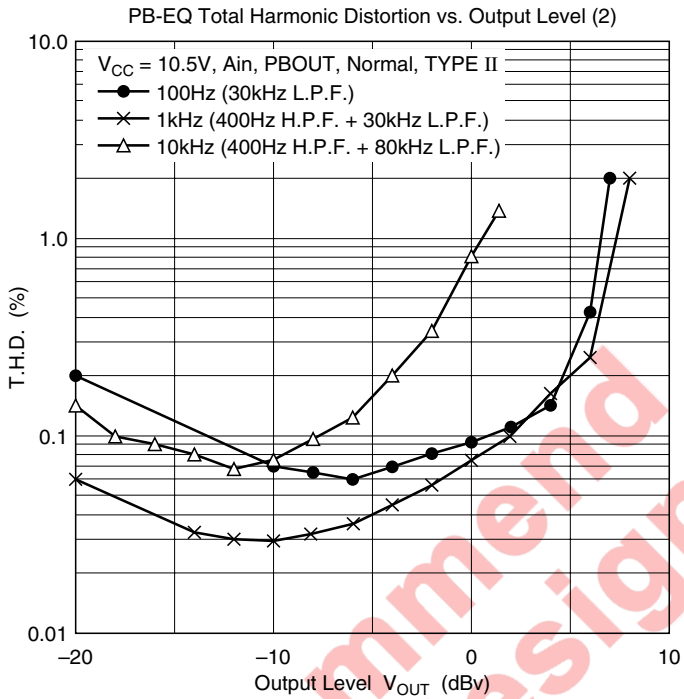

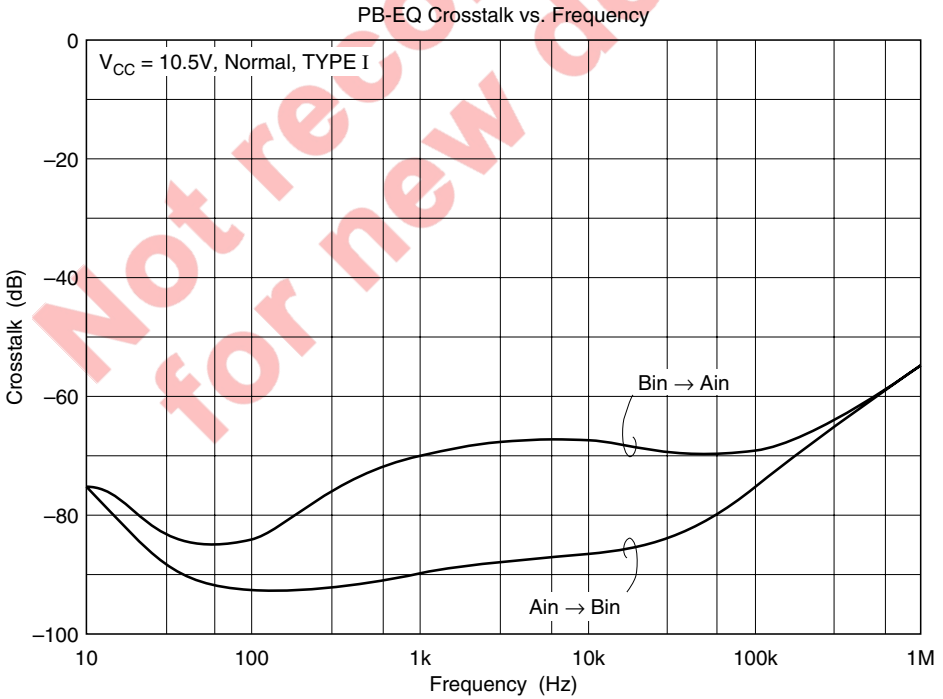
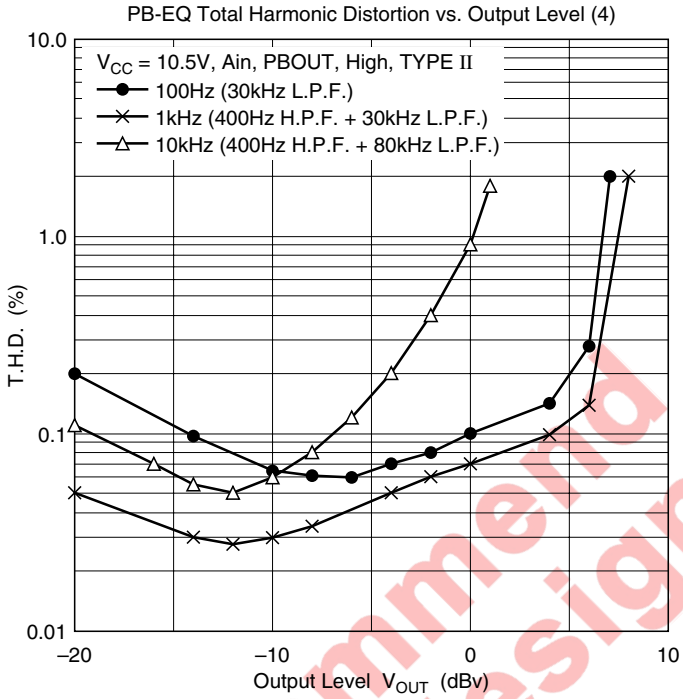

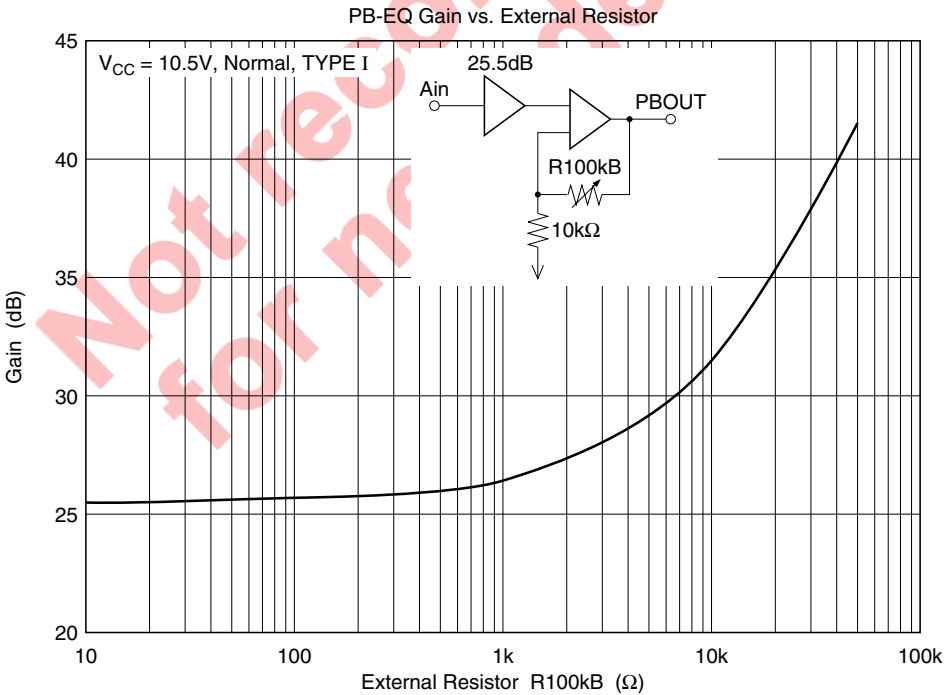
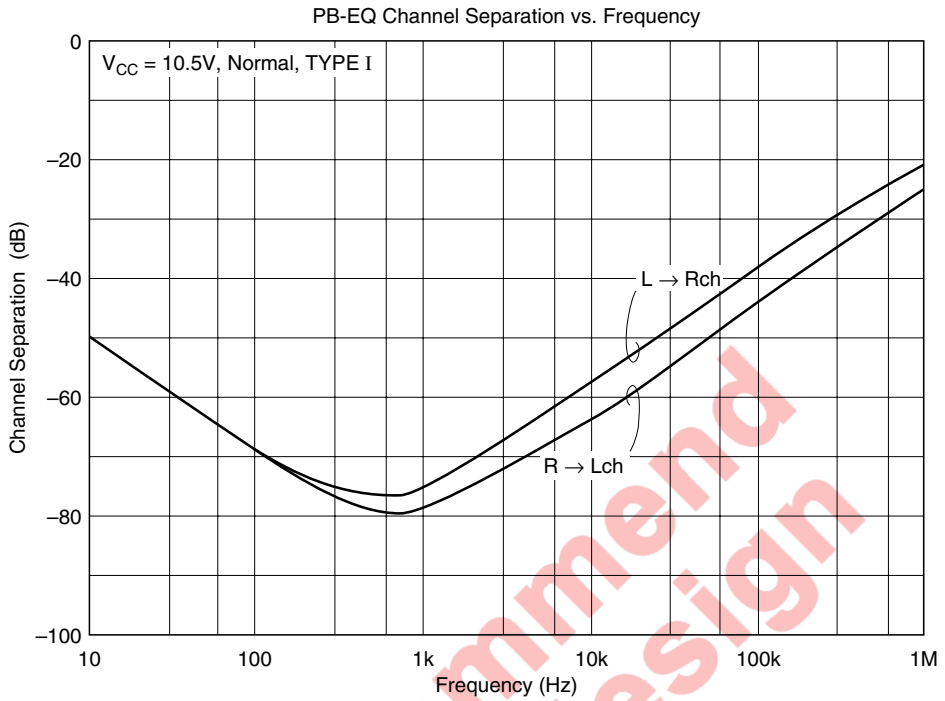

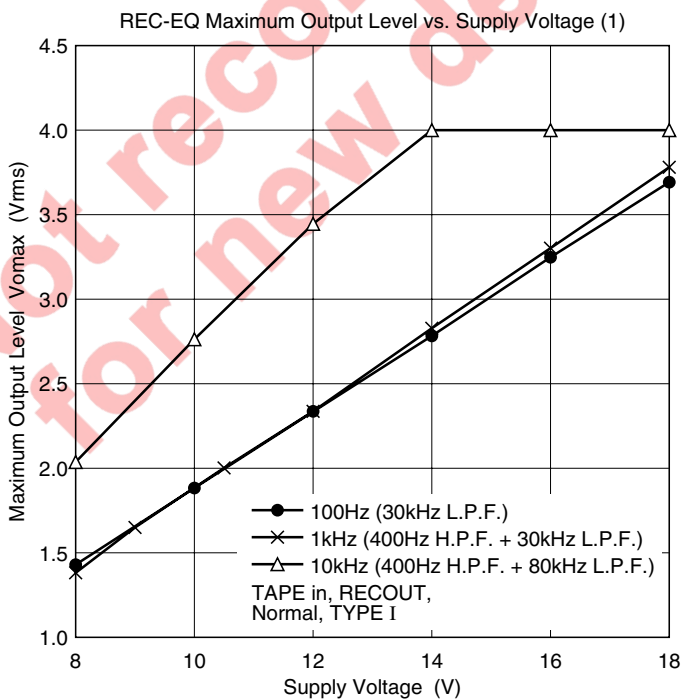
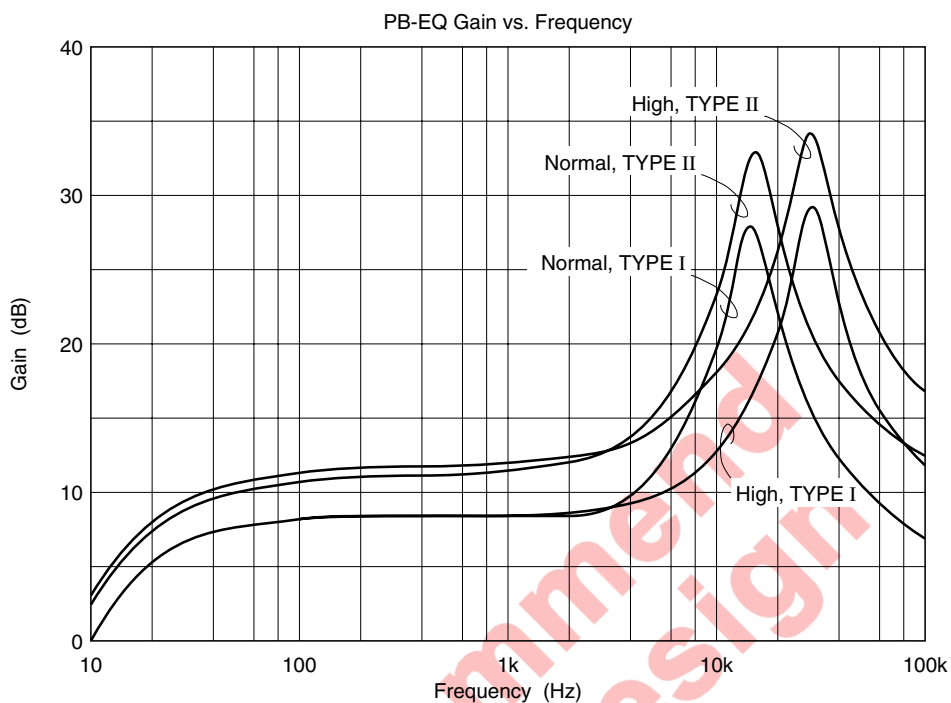

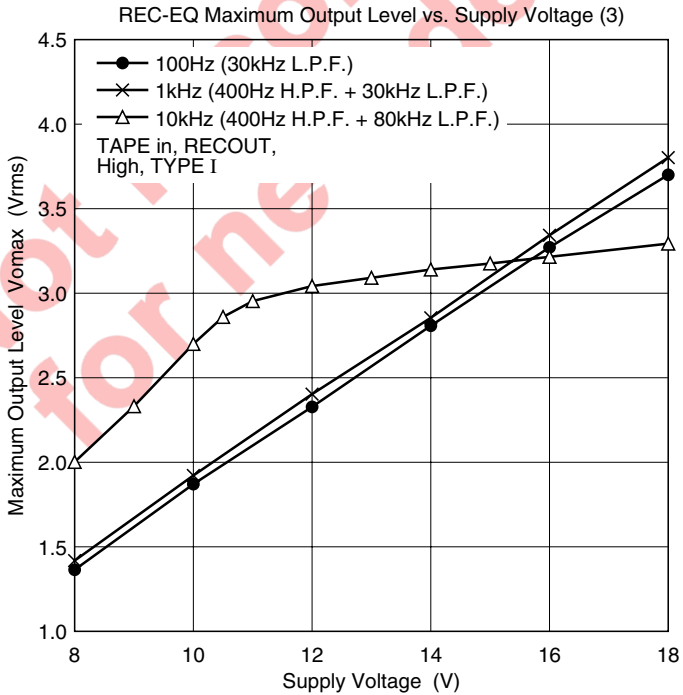
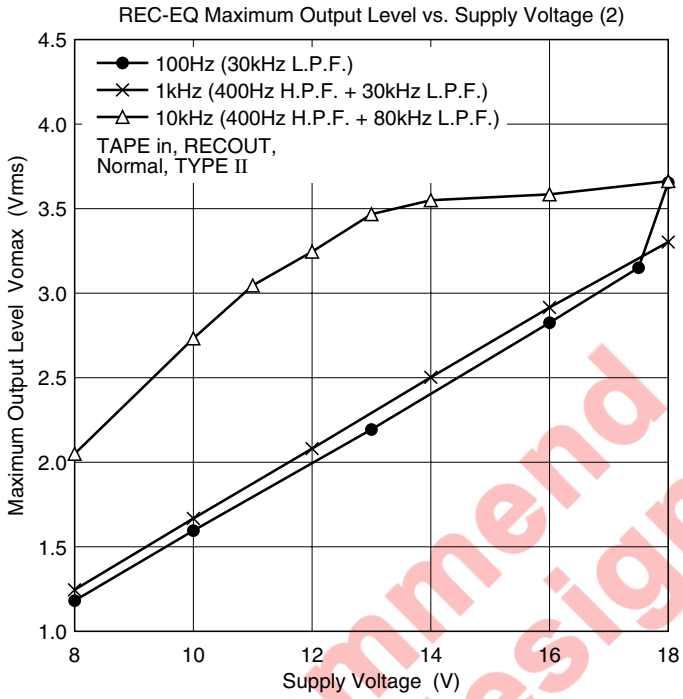

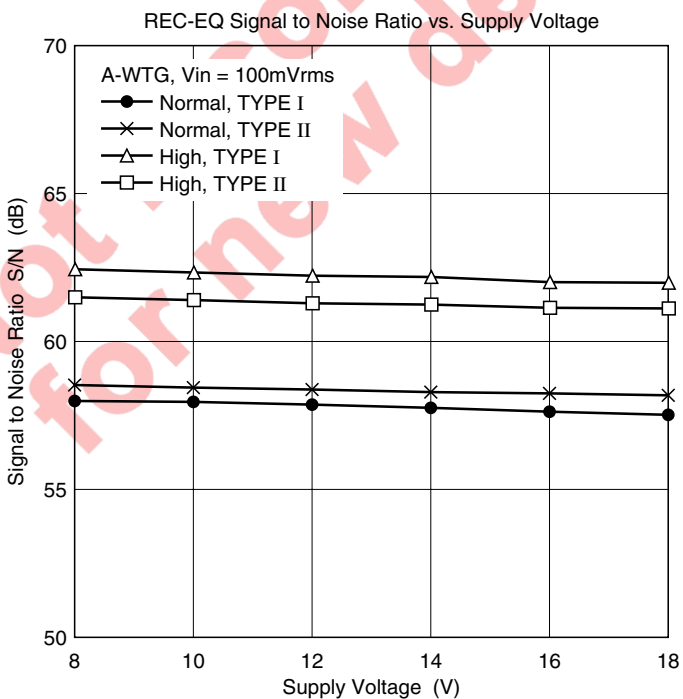
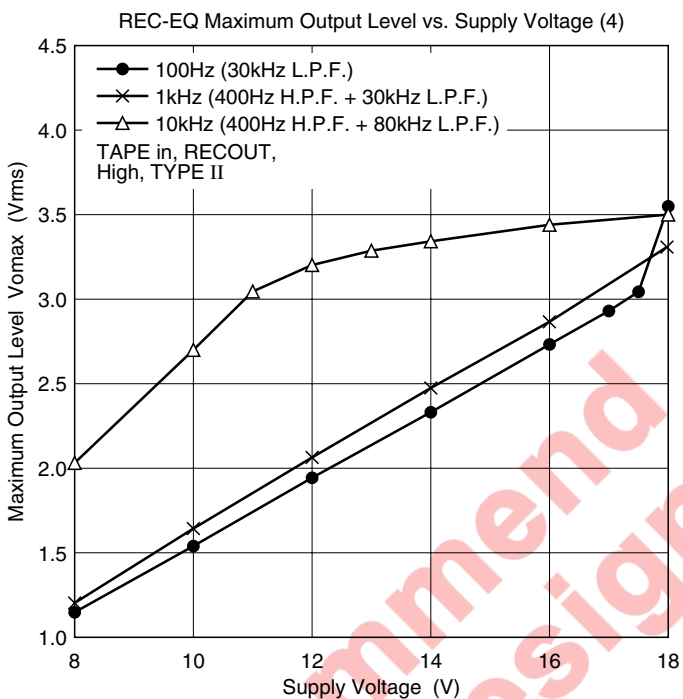

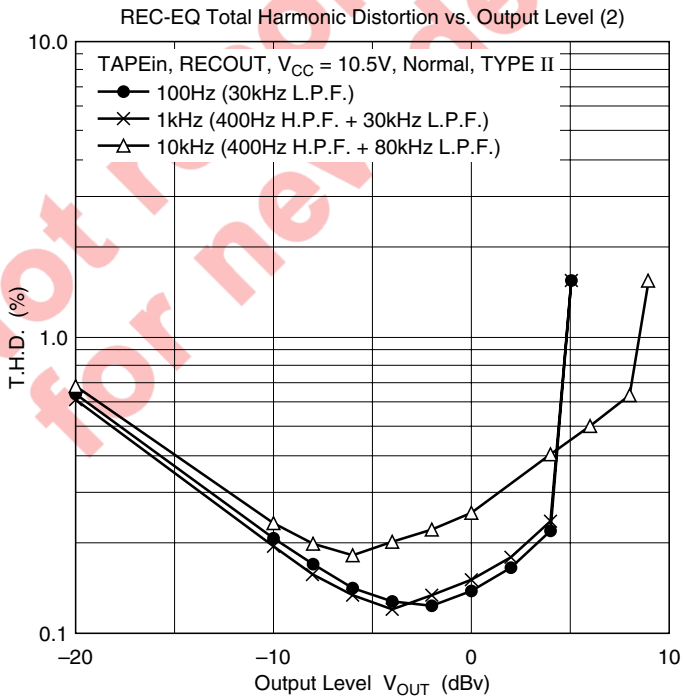
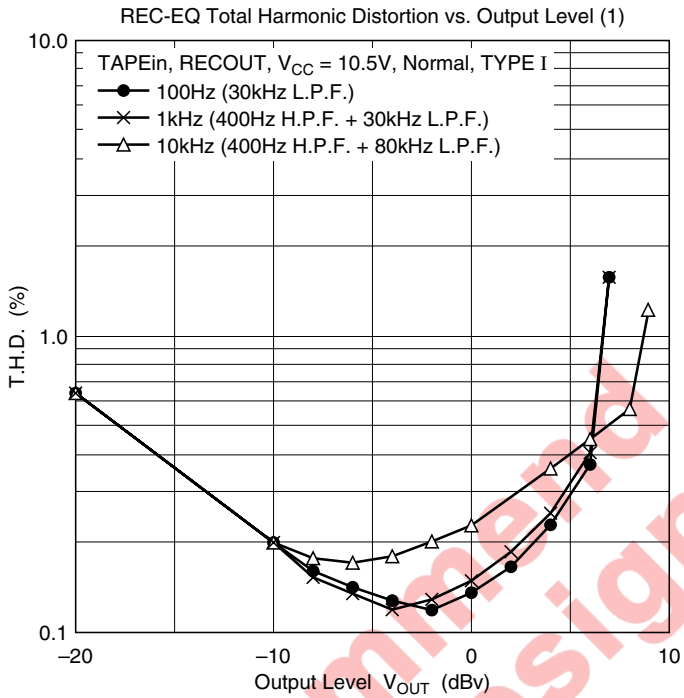

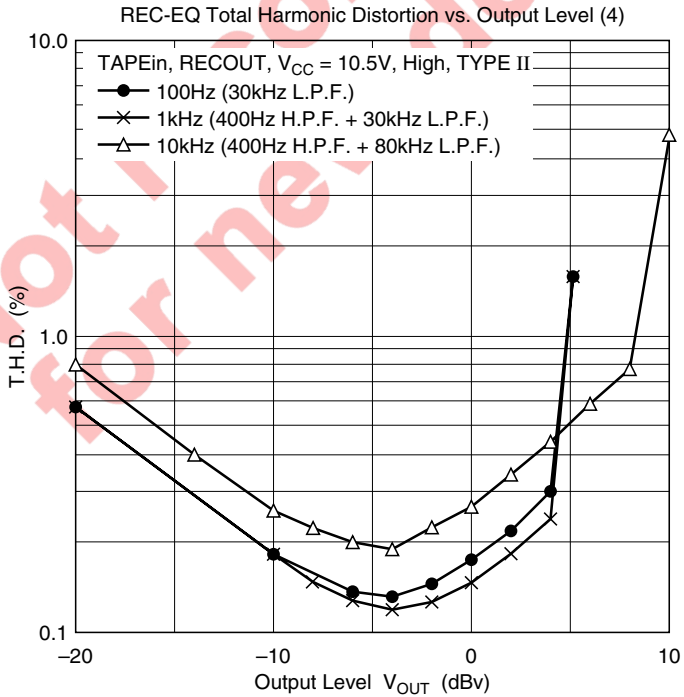
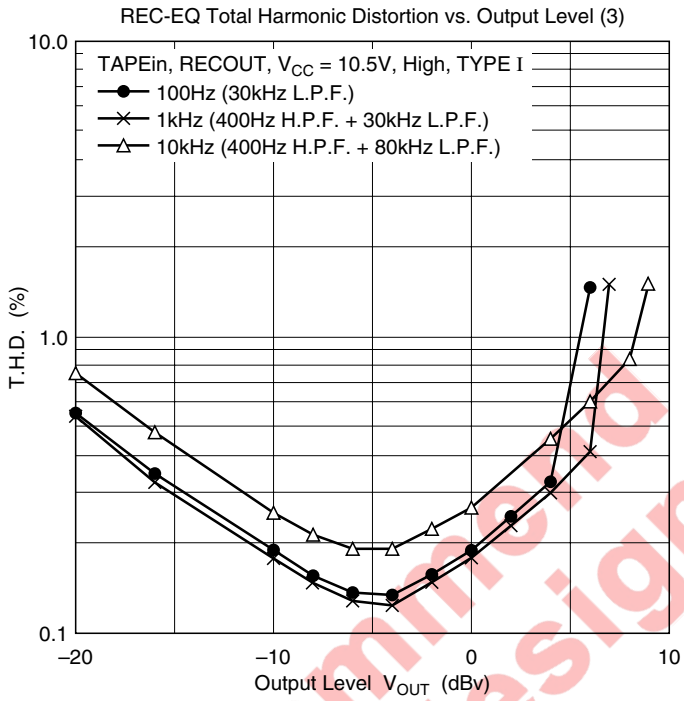

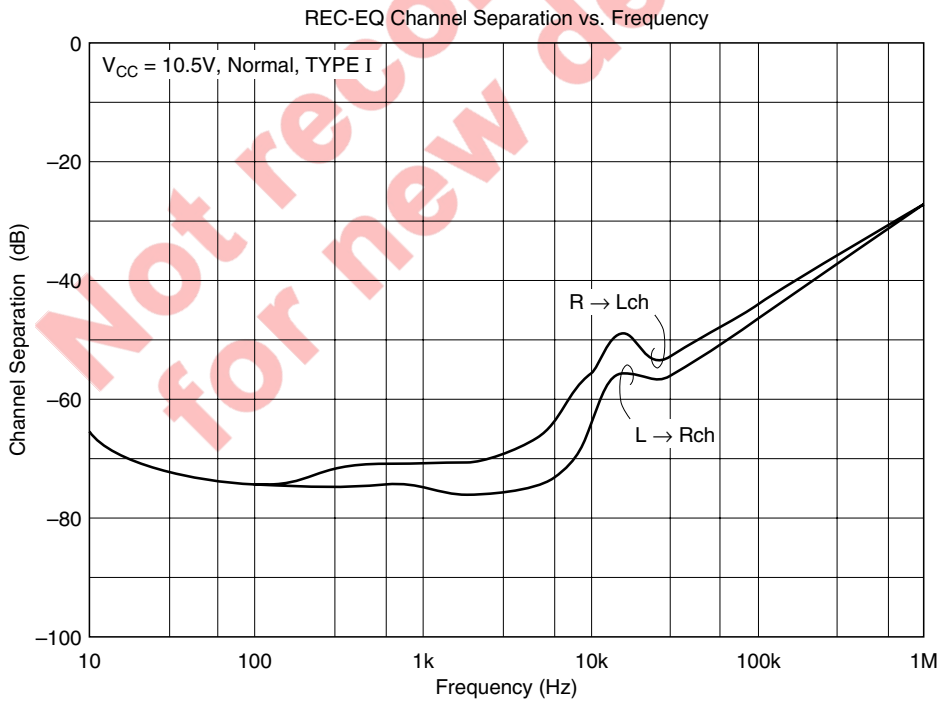
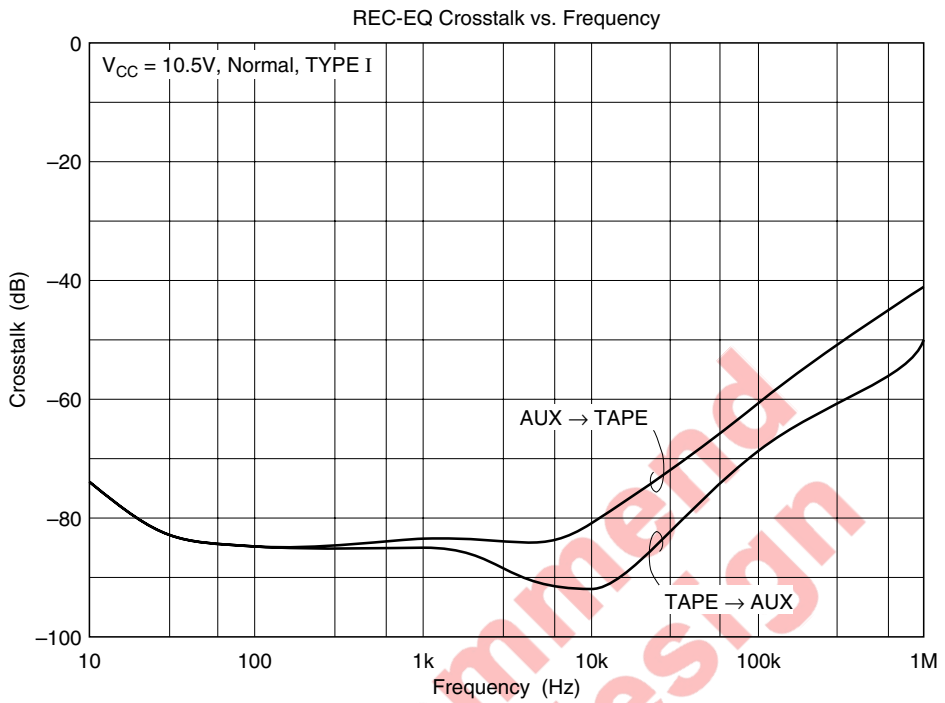

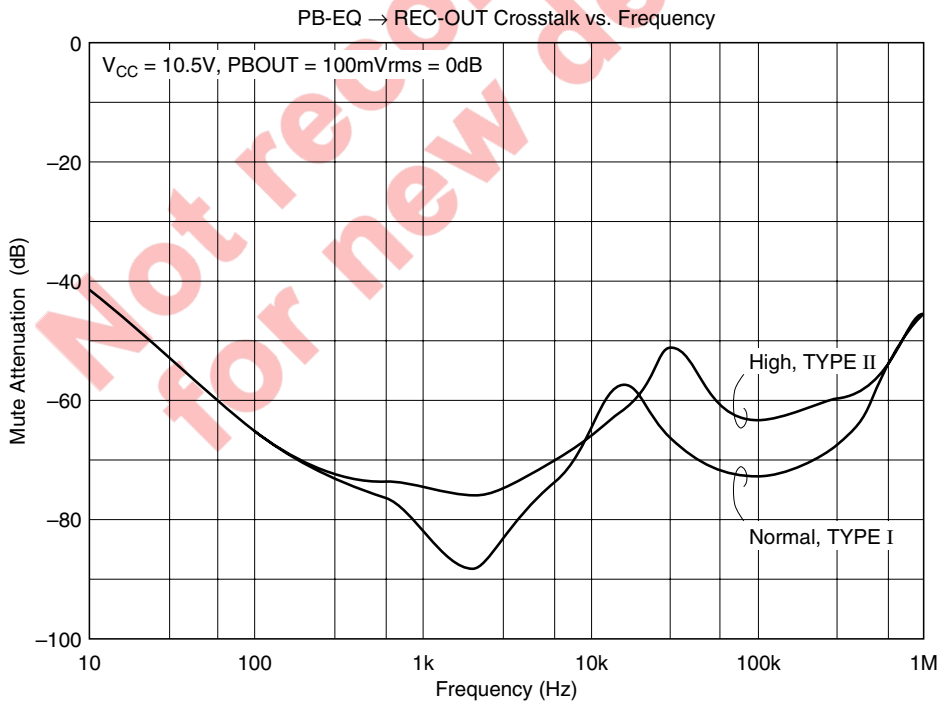
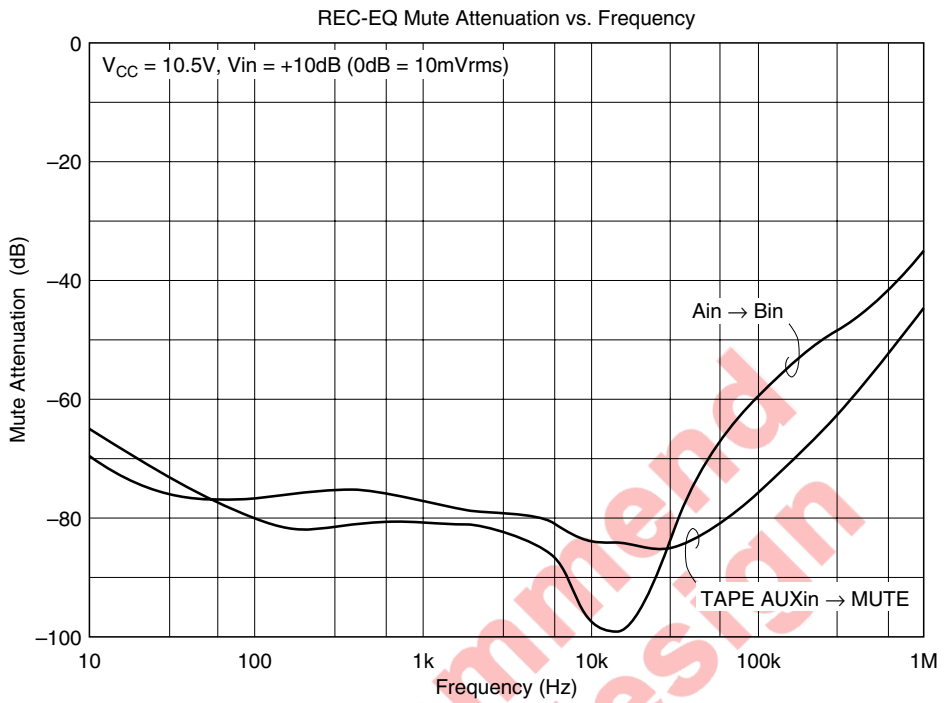

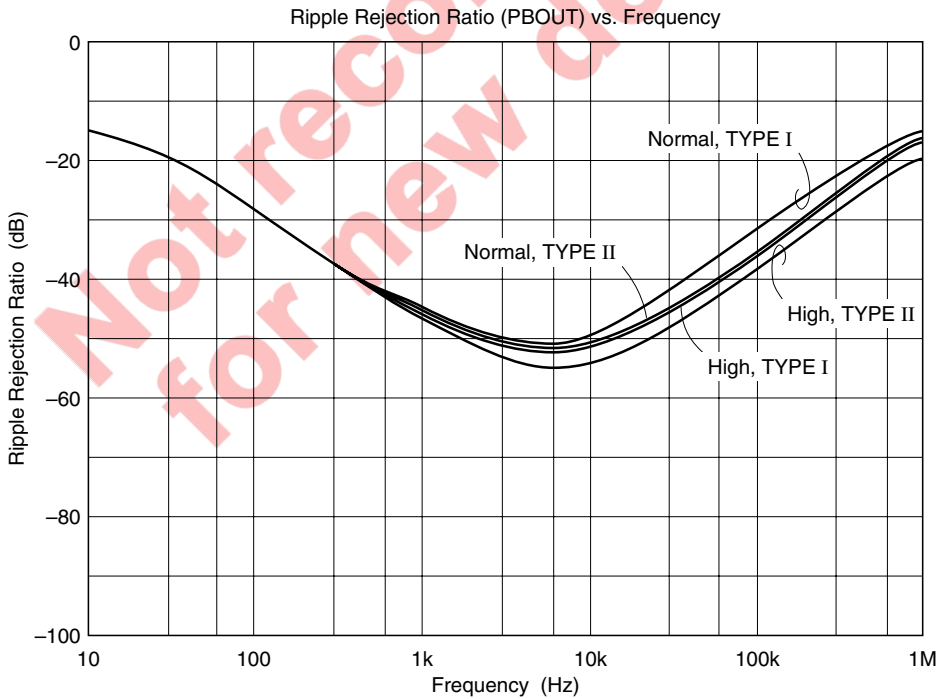
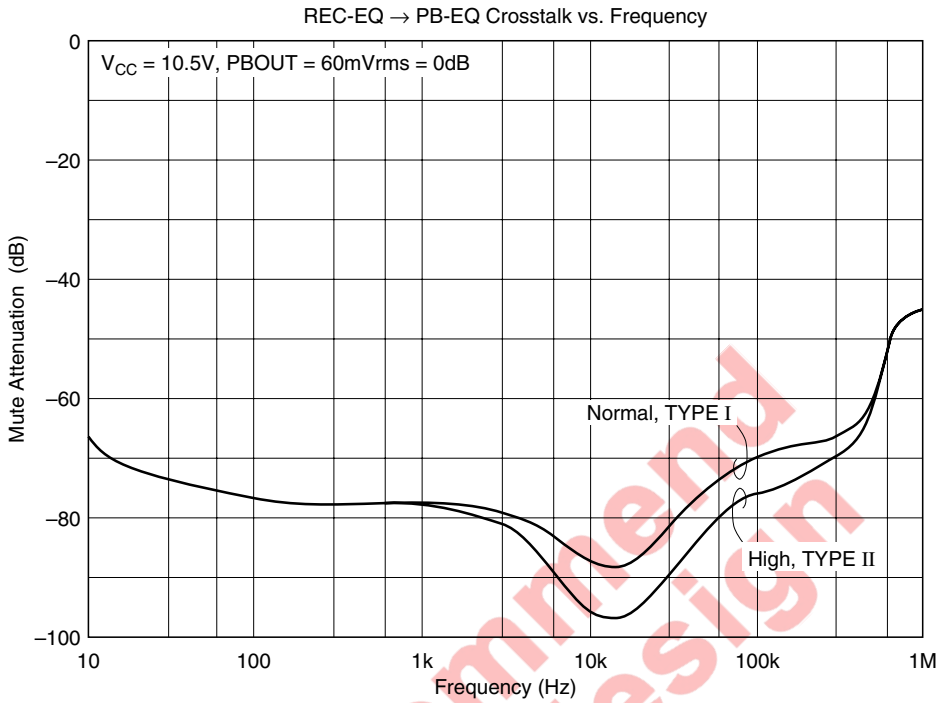

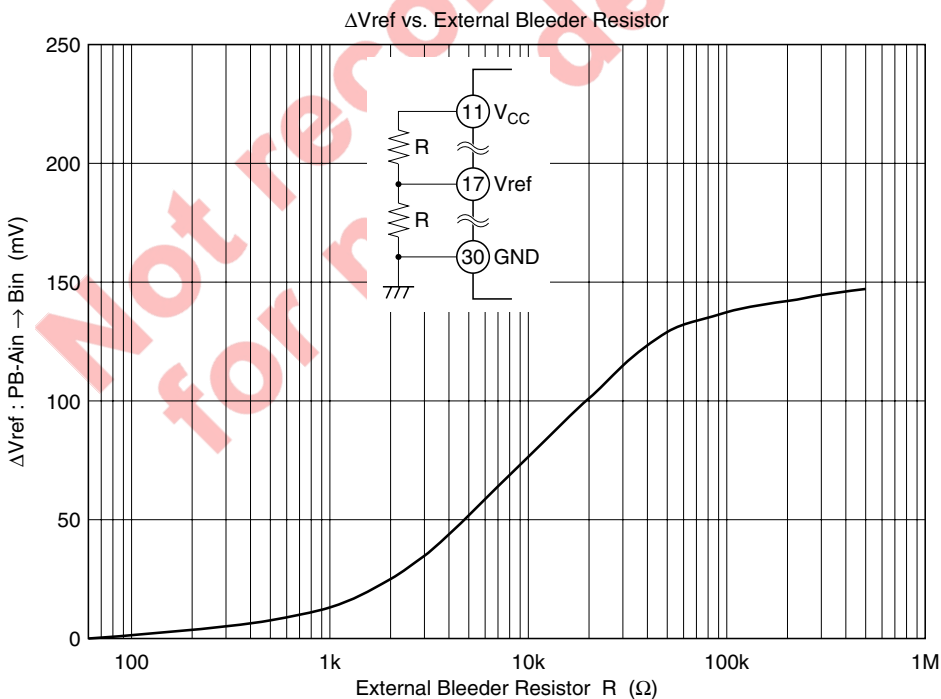
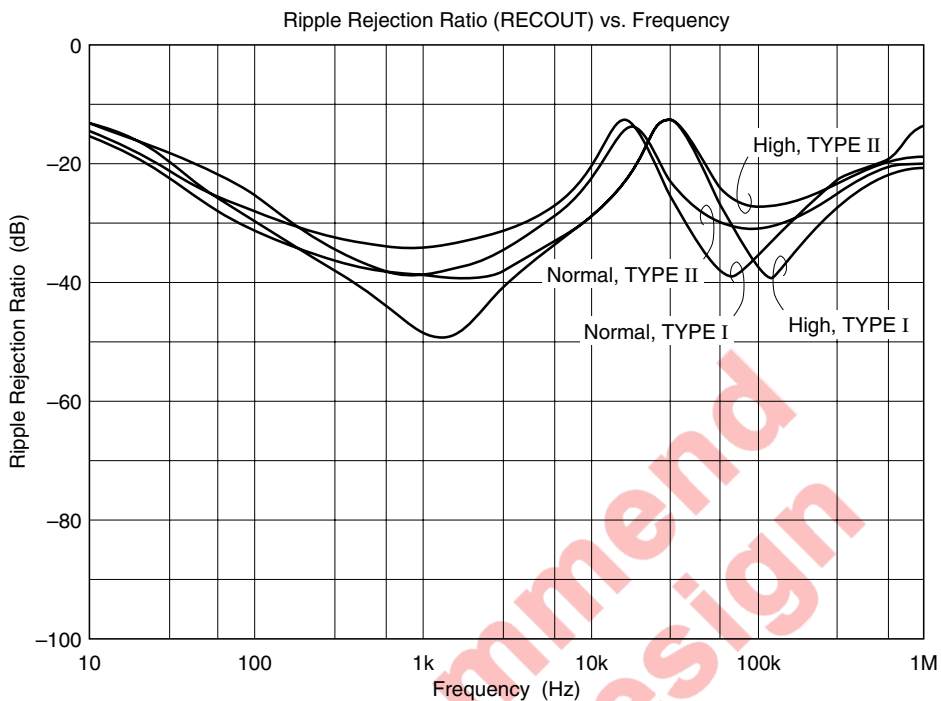

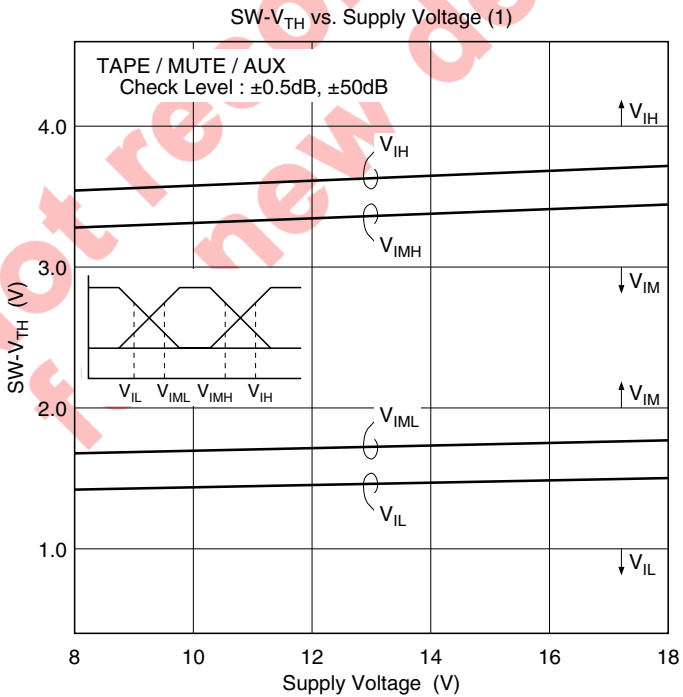
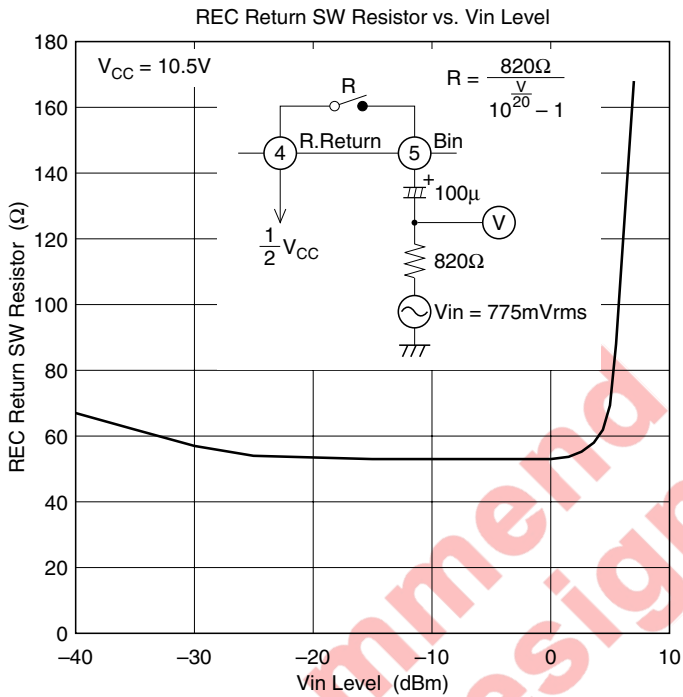

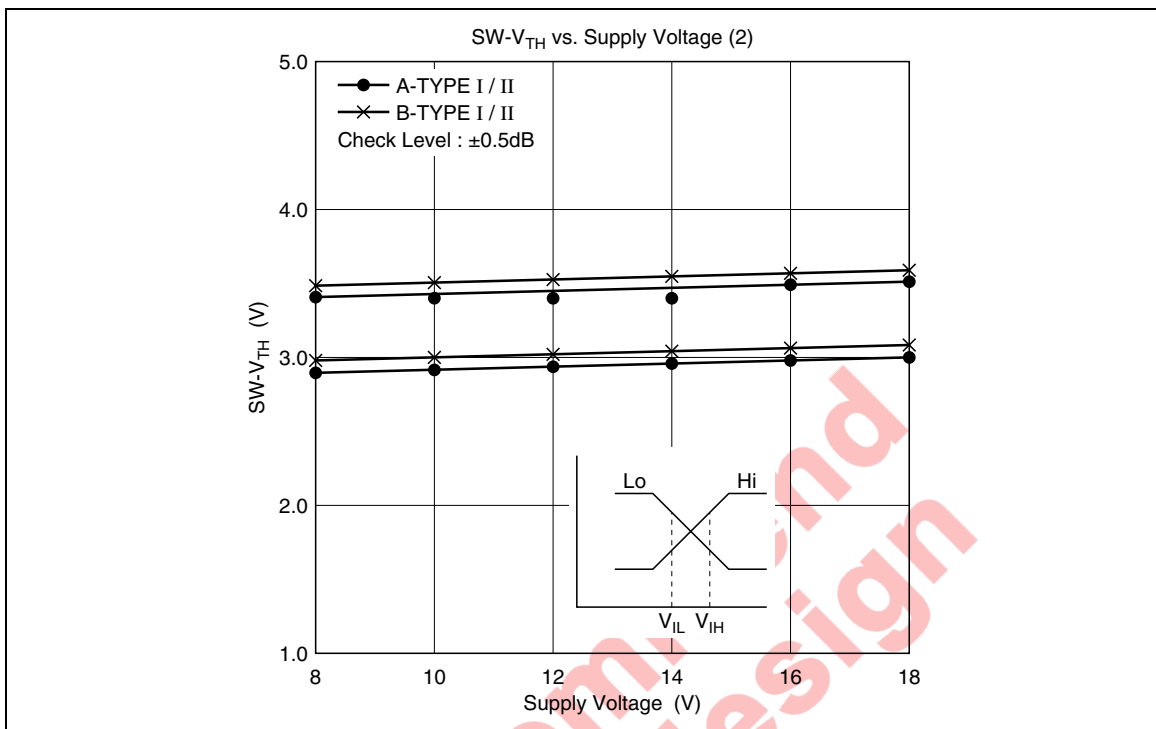

Package Dimensions

Unit: mm

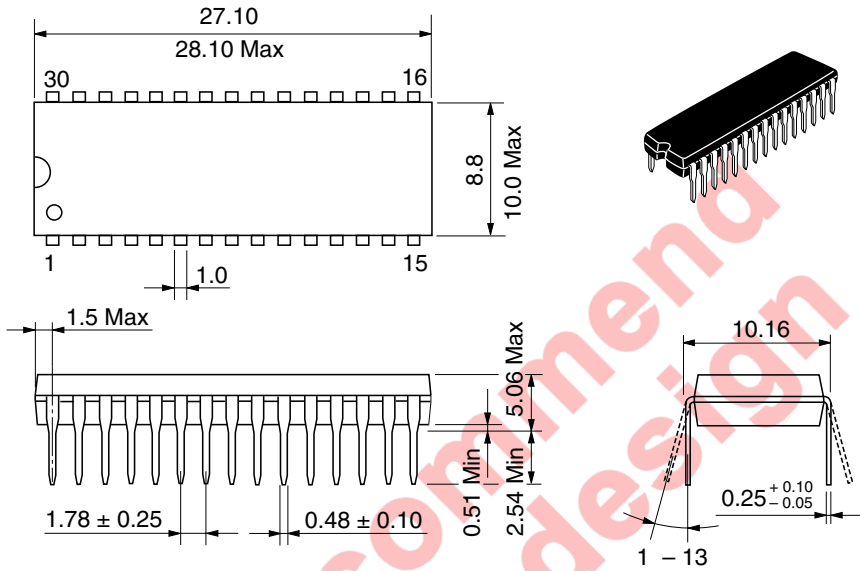

Hitachi Code	DP-30S
JEDEC Code	—
EIAJ Code	SC-549-30
Weight	1.98 g

Not recommended for new design

## Disclaimer

1. Hitachi neither warrants nor grants licenses of any rights of Hitachi's or any third party's patent, copyright, trademark, or other intellectual property rights for information contained in this document. Hitachi bears no responsibility for problems that may arise with third party's rights, including intellectual property rights, in connection with use of the information contained in this document.
2. Products and product specifications may be subject to change without notice. Confirm that you have received the latest product standards or specifications before final design, purchase or use.
3. Hitachi makes every attempt to ensure that its products are of high quality and reliability. However, contact Hitachi's sales office before using the product in an application that demands especially high quality and reliability or where its failure or malfunction may directly threaten human life or cause risk of bodily injury, such as aerospace, aeronautics, nuclear power, combustion control, transportation, traffic, safety equipment or medical equipment for life support.
4. Design your application so that the product is used within the ranges guaranteed by Hitachi particularly for maximum rating, operating supply voltage range, heat radiation characteristics, installation conditions and other characteristics. Hitachi bears no responsibility for failure or damage when used beyond the guaranteed ranges. Even within the guaranteed ranges, consider normally foreseeable failure rates or failure modes in semiconductor devices and employ systemic measures such as fail-safes, so that the equipment incorporating Hitachi product does not cause bodily injury, fire or other consequential damage due to operation of the Hitachi product.
5. This product is not designed to be radiation resistant.
6. No one is permitted to reproduce or duplicate, in any form, the whole or part of this document without written approval from Hitachi.
7. Contact Hitachi's sales office for any questions regarding this document or Hitachi semiconductor products.

## Sales Offices

# HITACHI

### Hitachi, Ltd.

Semiconductor & Integrated Circuits.

Nippon Bldg., 2-6-2, Ohte-machi, Chiyoda-ku, Tokyo 100-0004, Japan

Tel: Tokyo (03) 3270-2111 Fax: (03) 3270-5109

URL	NorthAmerica	: <a href="http://semiconductor.hitachi.com/">http://semiconductor.hitachi.com/</a>
	Europe	: <a href="http://www.hitachi-eu.com/hel/ecg">http://www.hitachi-eu.com/hel/ecg</a>
	Asia	: <a href="http://sicapac.hitachi-asia.com">http://sicapac.hitachi-asia.com</a>
	Japan	: <a href="http://www.hitachi.co.jp/Sicd/indx.htm">http://www.hitachi.co.jp/Sicd/indx.htm</a>

### For further information write to:

Hitachi Semiconductor  
(America) Inc.  
179 East Tasman Drive,  
San Jose, CA 95134  
Tel: <1> (408) 433-1990  
Fax: <1> (408) 433-0223

Hitachi Europe GmbH  
Electronic Components Group  
Dornacher Straße 3  
D-85622 Feldkirchen, Munich  
Germany  
Tel: <49> (89) 9 9180-0  
Fax: <49> (89) 9 29 30 00

Hitachi Europe Ltd.  
Electronic Components Group.  
Whitebrook Park  
Lower Cookham Road  
Maidenhead  
Berkshire SL6 8YA, United Kingdom  
Tel: <44> (1628) 585000  
Fax: <44> (1628) 585160

Hitachi Asia Ltd.  
Hitachi Tower  
16 Collyer Quay #20-00,  
Singapore 049318  
Tel : <65>-538-6533/538-8577  
Fax : <65>-538-6933/538-3877  
URL : <http://www.hitachi.com.sg>

Hitachi Asia Ltd.  
(Taipei Branch Office)  
4/F, No. 167, Tun Hwa North Road,  
Hung-Kuo Building,  
Taipei (105), Taiwan  
Tel : <886>-(2)-2718-3666  
Fax : <886>-(2)-2718-8180  
Telex : 23222 HAS-TP  
URL : <http://www.hitachi.com.tw>

Hitachi Asia (Hong Kong) Ltd.  
Group III (Electronic Components)  
7/F., North Tower,  
World Finance Centre,  
Harbour City, Canton Road  
Tsim Sha Tsui, Kowloon,  
Hong Kong  
Tel : <852>-(2)-735-9218  
Fax : <852>-(2)-730-0281  
URL : <http://www.hitachi.com.hk>

Copyright © Hitachi, Ltd., 2000. All rights reserved. Printed in Japan.  
Colophon 2.0