

Description

The ZMOD4510 Gas Sensor Platform detects air quality in a variety of indoor and outdoor applications. The module is a 12-pin LGA assembly (standard version 3.0 × 3.0 × 0.7 mm) that consists of a gas sense element and a CMOS signal conditioning IC. The module's sense element consists of a heater element on a silicon-based MEMS structure and a metal-oxide (MOx) chemiresistor. The signal conditioner controls the sensor temperature and measures the MOx resistance, which is a function of the gas concentration.

The device is ideal for monitoring and reporting Outdoor Air Quality (OAQ). The provided free firmware enables different ZMOD4510 features based on traditional and machine learning algorithms with an embedded artificial intelligence (AI) using the same hardware platform. This is used to determine the Air Quality Index (AQI) output, which is based on gases present. The outdoor air quality includes nitrogen dioxide (NO₂) and ozone (O₃). Alternatively, depending on the operation mode, the ZMOD4510 can measure selectively ozone in an ultra-low power (ULP) operation.

The measurement results can be read via an I2C interface with the user's microprocessor, which processes the data to determine the levels of gases present and to indicate the AQI based on international standards. With its latest ultra-low operating current consumption, the ZMOD4510 is an excellent choice for low-voltage and low power battery applications.

Typical Applications

- Air monitoring for nitrogen dioxide and ozone
- Detect unhealthy conditions in outdoor air
- Personal air quality monitors
- Smart City instrumentation
- Automation based on AQI (HVAC systems, building air purification systems)

Available Support

- ZMOD4510 Evaluation Kit
- Manuals, application notes, blog, and white papers
- Instructional videos
- Programming libraries, example codes, and algorithm support to optimize performance

Features

- Sensor output based on operation method:
 - Non-selective measurement of nitrogen dioxide (NO₂) and ozone (O₃)
 - Selective ozone (O₃) measurement using ultra-low power
- Supports international standards for air quality, such as the US Environmental Protection Agency (EPA)
- Customization for mobile, industrial, and consumer applications
- Heater driver and regulation loop for constant resistance, minimizing effect of environmental temperature on signal
- I²C interface: up to 400 kHz
- Built-in nonvolatile memory (NVM) for module-specific data
- Ultra-low average power consumption down to 0.2 mW
- Excellent for low-voltage and low-power battery applications
- No external trimming components required
- External reset pin (active-LOW)
- Siloxane resistant
- RoHS compliant
- Target operation temperature: -40°C to +65°C
- Supply voltage: 1.7V to 3.6 V
- Water and dustproof version available (IP67 certified)
- Available assembly sizes:
 - 3.0 × 3.0 × 0.7 mm (standard version)
 - 3.0 × 3.0 × 0.9 mm (IP67 version)

ZMOD4510 Application Circuit

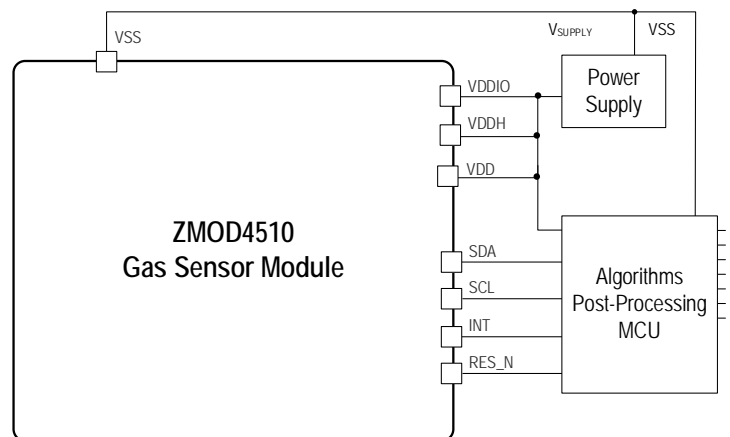

Contents

1.	Pin Information	4
1.1	Pin Assignments.....	4
1.2	Pin Descriptions.....	4
2.	Specifications	5
2.1	Absolute Maximum Ratings.....	5
2.2	Recommended Operating Conditions	5
2.3	Electrical Characteristics	6
3.	Block Diagram	7
4.	Sensor Module Characteristics.....	8
5.	Gas Sensor Module Characteristics	9
5.1	Air Quality Standard	9
5.2	Operation Mode 1: OAQ 1st Generation	9
5.3	Operation Mode 2: OAQ 2nd Generation	10
5.4	Sensor Module Algorithm and Firmware	10
5.5	Environmental Temperature and Humidity	11
5.6	Accuracy and Conditioning.....	11
6.	Assembly Restrictions, Operation, Integration Notes and Storage.....	12
7.	Test and Calibration	13
8.	I2C Interface and Data Transmission Protocol.....	13
9.	Related Websites and Software	15
10.	Package Outline Drawings	15
11.	Marking Diagram	15
12.	Ordering Information.....	16
13.	Glossary	17
14.	Revision History.....	18

List of Figures

Figure 1.	Pin Assignments for 12-LGA Module – Top View.....	4
Figure 2.	Humidity Influence on the Sensitivity for 100ppb NO ₂ in OAQ 1 st Gen Operation	11
Figure 3.	Typical Solder Profile.....	12
Figure 4.	I2C Data Transmission Protocol.....	14
Figure 5.	Bus Timing.....	14

List of Tables

Table 1.	Pin Descriptions.....	4
Table 2.	Absolute Maximum Ratings.....	5
Table 3.	Recommended Operating Conditions	5
Table 4.	Electrical Characteristics	6
Table 5.	Gas Sensor Module Characteristics	8
Table 6.	Air Quality Index Levels Described by the EPA ⁱⁱ	9
Table 7.	Typical ZMOD4510 Sensor Module Accuracy Achievable	11
Table 8.	Final Test Parameters	13
Table 9.	Bus Timing Characteristics.....	14
Table 10.	Package Options	15

1. Pin Information

1.1 Pin Assignments

Figure 1. Pin Assignments for 12-LGA Module – Top View

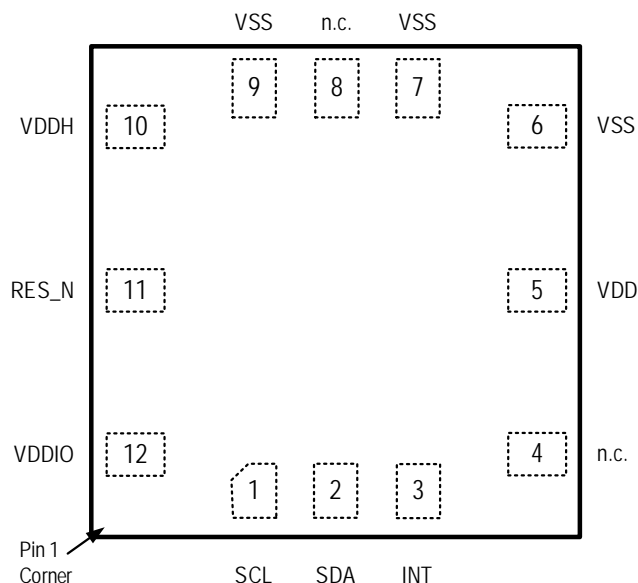

1.2 Pin Descriptions

Table 1. Pin Descriptions

Pin Number	Name	Type	Description
1	SCL	Input	Serial clock for the I2C interface.
2	SDA	Input/Output	Serial data for the I2C interface. Default 7-bit slave address: 33 _{HEX} .
3	INT	Output	Interrupt signal (push-pull): <ul style="list-style-type: none"> ▪ HIGH when a measurement is running ▪ LOW when a measurement has finished Note, use edge detection on falling edge!
4	n.c.	–	Do not connect.
5	V _{DD}	Supply	Voltage supply for the ZMOD4510.
6	V _{SS}	Ground	Ground reference for the ZMOD4510.
7	V _{SS}	Ground	Ground reference for the ZMOD4510.
8	n.c.	–	Do not connect.
9	V _{SS}	Ground	Ground reference for the ZMOD4510.
10	V _{DDH}	Supply	Voltage supply for the integrated heater in the ZMOD4510.
11	RES_N	Input	ZMOD4510 reset; active low.
12	V _{DDIO}	Supply	Voltage supply for I/O-interface in ZMOD4510.

2. Specifications

2.1 Absolute Maximum Ratings

Note: The absolute maximum ratings are stress ratings only. The ZMOD4510 may not be operable below and above the recommended operating conditions in Table 2. Stresses exceeding the absolute maximum ratings will change the sensor module accuracy; lead to imprecision, and eventually cause irreversible damage to the device. In addition, extended exposure to stresses above the recommended operating conditions may affect device reliability. Renesas does not recommend designing to the “Absolute Maximum Ratings.”

Table 2. Absolute Maximum Ratings

Symbol	Parameter	Minimum	Maximum	Unit
$V_{DD}, V_{DDH}, V_{DDIO}$	Maximum Analog and I/O Supply Voltage	-0.4	3.63	V
V_{A_IO}, V_{D_IO}	Maximum Voltage at all Analog and Digital I/O Pins	-0.5	$V_{DDIO} + 0.5$	V
	Maximum Difference in Voltage between V_{DD} and V_{DDH} Pins	-	0.4	V
I_{IN}	Input Current into any Pin Except Supply Pins (Latch-Up Immunity)	-100	100	mA
V_{HBM1}	Electrostatic Discharge Tolerance – Human Body Model (HBM)	-	2000	V
V_{CDM}	Electrostatic Discharge Tolerance – Charged Device Model (CDM) on Packaged Module	-	1500	V
$T_{AMB-MAX}$	Maximum Ambient Temperature Range of Sensor Module	-40	125	°C
T_{STOR}	Storage Temperature	-50	125	°C

2.2 Recommended Operating Conditions

Note: The reference for all voltages is V_{SS} .

Table 3. Recommended Operating Conditions

Symbol	Parameter	Minimum	Typical	Maximum	Unit
V_{DD}	Supply Voltage for ZMOD4510 Sensor Module	1.7	-	3.6	V
T_{AMB}	Ambient Temperature Range for Sensor Module Operation	-40	-	65	°C
$T_{OPERATION}$	Operation Temperature Sequence of Sense Element [a]	200		450	°C

[a] Controlled via API in firmware and EVK software.

2.3 Electrical Characteristics

The following values are valid at operating conditions unless noted otherwise.

Table 4. Electrical Characteristics

Symbol	Parameter	Conditions	Minimum	Typical	Maximum	Unit
	Average Power: OAQ 1 st Gen	Outdoor Air Quality	-	21	-	mW
	Average Power: OAQ 2 nd Gen	Selective ozone with ultra-low power	-	0.2	-	mW
I _{ACTIVE}	Supply Current, Active Mode including Heater Current for OAQ 1 st Gen	At V _{DD} = 1.8 V	-	11	13	mA
		At V _{DD} = 3.3 V	-	8	10	mA
I _{ACTIVE}	Supply Current, Active Mode including Heater Current for OAQ 2 nd Gen	At V _{DD} = 1.8 V	-	10	12	mA
		At V _{DD} = 3.3 V	-	6	8	mA
I _{SLEEP}	Current during measurement delays	Sleep Mode ASIC	-	450	-	nA
PSRR	Power Supply Rejection Ratio	V _{DD} ≥ 2.0 V	-	30	-	dB
	Timing Accuracy (Valid for Measurements Only); (Sleep Timer is ±20%)	At room temperature; for timings derived from the internal clock	-2	-	2	%
		Over-temperature range; for timings derived from the internal clock	-0.1	-	0.1	%/K
τ _{ADC}	ADC Resolution		10	-	16	Bit
t _{STA1}	Start-up Time: V _{DD} Ramp up to Interface Communication		-	-	1	ms
f _{C,I2C}	I2C Clock Frequency		-	-	400	kHz
t _{VPP}	NVM Programming Time		-	6	16	ms
t _{RET_FTP}	Data Retention	85°C junction temperature	10	-	-	years
	NVM Programming Cycles		1000	-	-	cycles
	Default Communication Address	7-bit slave address	-	33 _{HEX}	-	-
	Blocking Capacitor for Power Supply	Ceramic type; recommended to be placed close to V _{DDH} of the gas sensor module	100	-	-	nF

3. Block Diagram

Note: See section 8 for definitions of abbreviations.

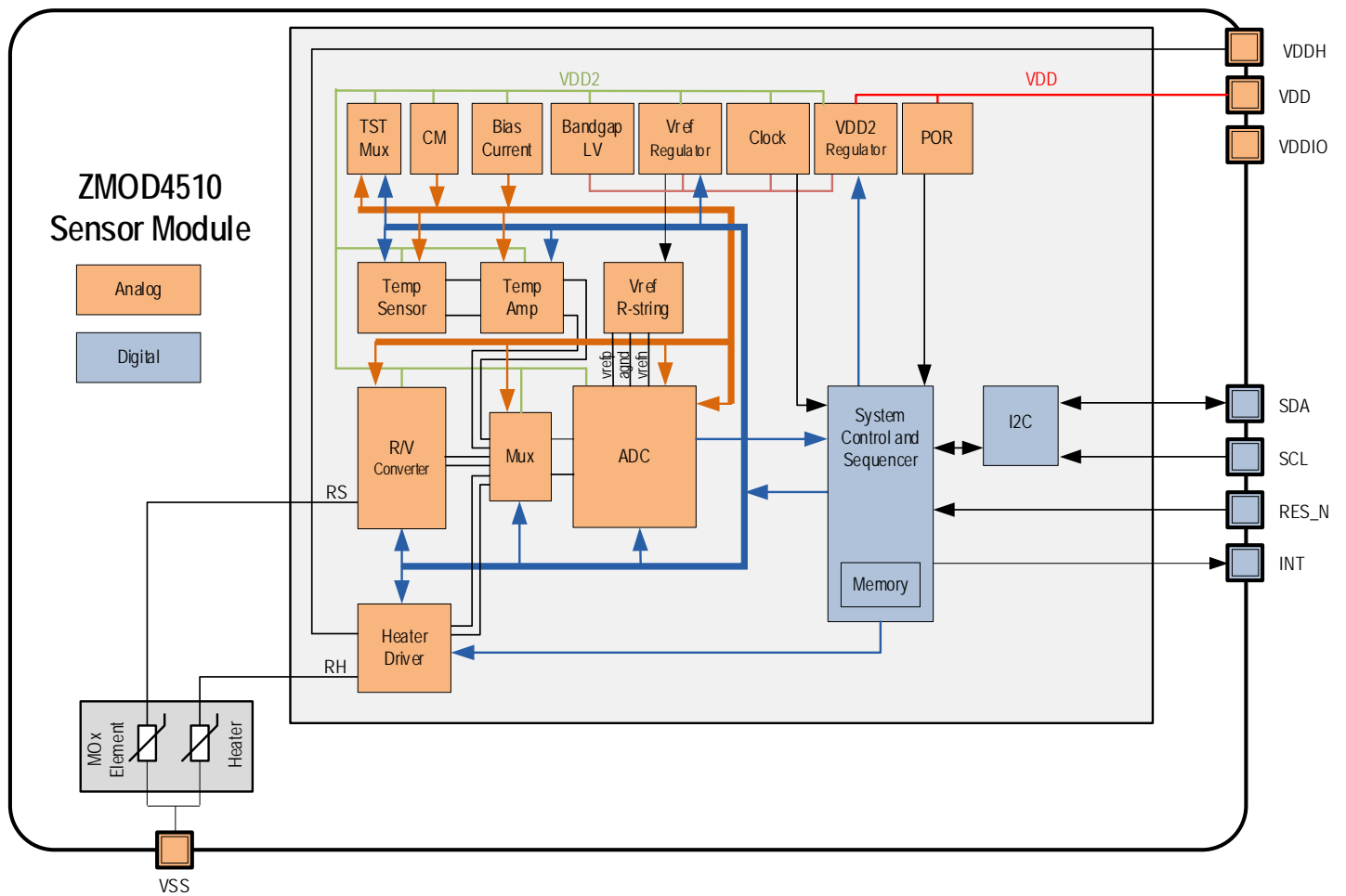

4. Sensor Module Characteristics

The ZMOD4510 Gas Sensor Module detects typical gases based on studies and international standards for outdoor air quality. Characteristic module parameters are shown in Table 5. The ZMOD4510 uses a sequence of applied temperatures in order to sample the air and report an Air Quality Index (AQI) based on the EPA standard¹. The sensor does not require an active or direct airflow onto the sensor module because diffusion of ambient gas does not limit the sensor response time.

Important: The ZMOD4510 can also detect safety-relevant gases; however, the sensor module is not designed to detect these interferants reliably and therefore it is not approved for use in any safety-critical or life-protecting applications. It must not be used in such applications, and Renesas disclaims all liability for any such use.

Table 5. Gas Sensor Module Characteristics

Symbol	Parameter	Conditions	Minimum	Typical	Maximum	Unit ^[a]
AQI	Air Quality Index	OAQ 1 st Gen: Rating according to EPA for ozone and nitrogen dioxide	0		500	
		OAQ 2 nd Gen: Rating according to EPA for ozone	0		500	
	Measurement Range OAQ 1 st Gen	Ozone (non-selective)	20		500	ppb
		Nitrogen dioxide (non-selective)	20		500	ppb
	Measurement Range OAQ 2 nd Gen	Ozone (selective)	20		500	ppb
		NO ₂ cross sensitivity at 200ppb		25		AQI Level
RH	Humidity Range	Non-condensing	5		90	% RH
T	Temperature Range	Typical outdoor environment	-20		50	°C
		Extended range	-40		65	°C

[a] The abbreviation ppb stands for “parts per billion” and is a molar ratio with the exponent of 10⁻⁹.

¹ AirNow, US Environmental Protection Agency, Air Quality Index (AQI) Basics; available at: <https://airnow.gov/index.cfm?action=aqibasics.aqi>

5. Gas Sensor Module Characteristics

The ZMOD architecture leverages different “Methods of Operation” which use time, temperature, and signatures from gases that enable unique signals from a highly trained machine learning system and makes use of embedded artificial intelligence (AI) technology. This section discusses the different operation modes of the ZMOD4510. Currently, two operation modes are released using the same ZMOD4510 hardware:

Family of Outdoor Air Quality (OAQ) software releases:

- Operation Mode 1 – OAQ 1st Generation: Measurement of Air Quality
- Operation Mode 2 – OAQ 2nd Generation: Selective Ozone featuring Ultra-Low Power

In addition, details for sensitivity, reliability, sample rates, and sensor module influences are explained in detail in the following sections. All graphs and information show the typical responses that are to be expected from the sensor module upon exposure to a variety of test conditions. For more information, including application notes, white papers, blog, and manuals, visit the [ZMOD4510](#) product page.

5.1 Air Quality Standard

There are many sources of poor air, especially outdoors, that can elevate the Air Quality Index (AQI). Renesas has adopted the definition of Air Quality and its impact on user health and comfort proposed by the US Environmental Protection Agency (EPA); see Table 6ⁱⁱ. Depending on its operation mode, the ZMOD4510 Gas Sensor Module can detect the presence of elevated ozone (O₃) and nitrogen dioxide (NO₂) levels or selectively ozone levels as described by the EPA. Additional information on this topic, chemical background information, and measurement technologies is available in Renesas’ *ZMOD4510 White Paper – Overview Outdoor Air Quality*.

Table 6. Air Quality Index Levels Described by the EPAⁱⁱ

Air Quality Index (AQI)	Level of Concern and Air Quality Condition	O ₃ Concentration 1h average [ppb] ^[a]	O ₃ Concentration 8h average [ppb]	NO ₂ Concentration 1h average [ppb]	Color Code
0 to 50	Good	0 to 62	0 to 54	0 to 53	Green
51 to 100	Moderate	63 to 124	55 to 70	54 to 100	Yellow
101 to 150	Unhealthy for Sensitive Groups	125 to 164	71 to 85	101 to 360	Orange
151 to 200	Unhealthy	165 to 204	86 to 105	361 to 649	Red
201 to 300	Very unhealthy	205 to 404	106 to 200	650 to 1249	Purple
301 to 500	Hazardous	405 to 604	-	1250 to 2049	Maroon

[a] For OAQ 1st Gen ozone is always considered from a 1-hour class; however, in case the 1-hour value is not available a linear approach was assumed to calculate the AQI value.

5.2 Operation Mode 1: OAQ 1st Generation

This mode of operation allows a general measurement of Air Quality, including non-selective measurement of nitrogen dioxide (NO₂) and ozone (O₃). With a sample rate of 60 seconds each concentration is considered from a 1-hour class; however, in case the 1-hour value is not available by the EPA (“Good” and “Moderate” levels) a linear approach was assumed to calculate the AQI value. AQI values above 500 are considered beyond the AQI. The reported AQI from the ZMOD4510 sensor is derived from the calculated NO₂ and O₃ concentration present.

ⁱⁱ AirNow, US Environmental Protection Agency, Air Quality Index (AQI) Basics; available at: <https://airnow.gov/index.cfm?action=aqibasics.aqi>

5.3 Operation Mode 2: OAQ 2nd Generation

This mode of operation allows the selective measurement of ozone (O_3) featuring Ultra-Low Power with an average consumption of 0.2mW during its fast sample rate of 2 seconds. The second generation OAQ algorithm is tuned to ozone detection and the cross-sensitivity response to NO_2 is reported as less than 25 AQI even at NO_2 levels up to 200ppb. The AQI output is according to the EPA standard and differentiated between 1 hour and 8 hours exposures (concentration dependent). For operation outdoors it is recommended to follow the EPA standard, which is called "EPA AQI" in the output files. However, for fast changing environments (e.g., during evaluation, testing, and system checks), it is recommended to use the "FAST AQI" signal, which is the same AQI calculation based on a 1-minute average. The algorithm is tailored for best accuracy in the typical environmental range of 20 to 100ppb and can report up to 500ppb. AQI values above 500 are considered beyond the AQI.

5.4 Sensor Module Algorithm and Firmware

To operate the ZMOD4510, the software and libraries provided by Renesas should be used. The algorithm for the user's microprocessor always uses the raw output signals from the ZMOD4510, which are resistances, to determine the level of gases present. Depending on the microprocessor and compiler used, the firmware and its algorithms require 10 to 20 kB flash size. All algorithms feature an automated baseline correction function, ensuring that the module can learn from its environment and distinguish elevated levels of gases under all conditions. The proprietary metal oxide (MOx) used in the sensor ensures that the sensor module can respond effectively to changing ozone and nitrogen dioxide levels, respectively, during long-term operation. Therefore, the user focus should always be on the relevant output parameters: the air quality index (AQI) and/or ozone concentration.

For implementing the sensor module in a customer-specific application, detailed information on the programming is available. More information and guidance on the firmware integration, architecture, and supported platforms are available in the *ZMOD4510 Programming Manual – Read Me*. Code Examples in C and additional firmware descriptions for API, HAL, libraries, etc., are included at no cost in the downloadable firmware package from the [ZMOD4510](#) product page.

5.5 Environmental Temperature and Humidity

The sensor module is tested, qualified, and functional in the operation range of -40°C to +65°C. Figure 2 shows the module's sensitivity for OAQ 1st Gen during operation to variations in relative humidity while stimulated with 100ppb nitrogen dioxide (NO₂). Due to the low influence of humidity, there is no additional humidity measurement and no algorithmic compensation necessary for OAQ 1st Gen. In OAQ 2nd Gen operation, an additional temperature and humidity measurement is recommended and the algorithm has an auto-compensation included. If no temperature and humidity data are provided as input, the algorithm will use default values, which may lead to an offset of ±1 EPA level according to Table 6.

Figure 2. Humidity Influence on the Sensitivity for 100ppb NO₂ in OAQ 1st Gen Operation

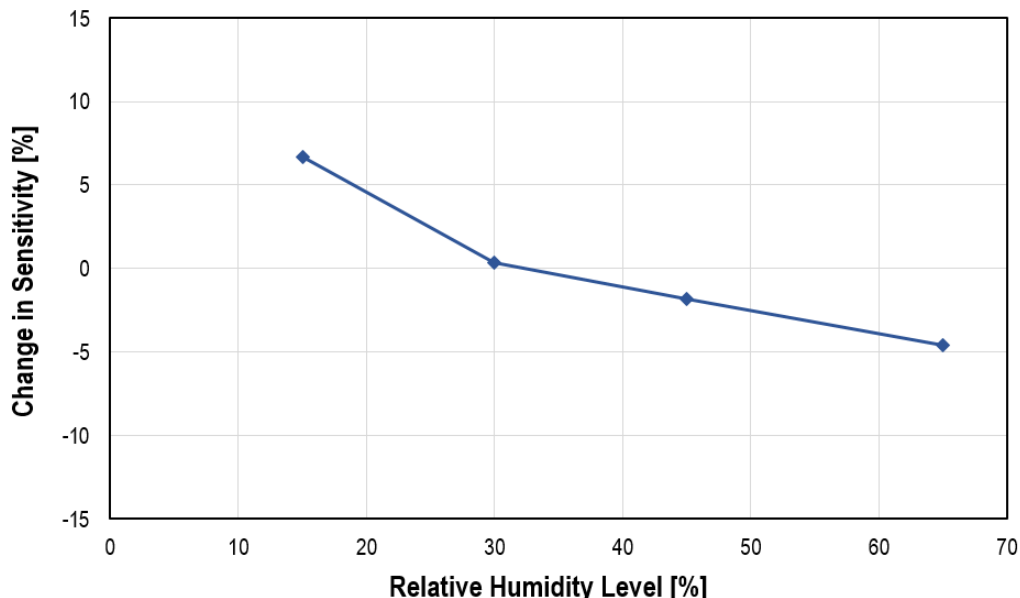

5.6 Accuracy and Conditioning

All Renesas gas sensor modules come with electrical and chemical factory calibration with data stored in the module's nonvolatile memory (NVM). Using the software provided by Renesas and the calibration coefficients in the NVM will result in stable measurements of the AQI levels discussed in section 5.1. The ZMOD4510 in OAQ 1st Gen operation will respond to typical outdoor gases after a warm-up time of 60 min, consisting of 20 min for stabilization and 40 min for baseline finding. For OAQ 2nd Gen operation a response to ozone will be seen after a warm-up time of 30 min. In all operation modes a conditioning period of 48 hours followed by a sensor module restart in an ambient environment is recommended to improve stability and obtain maximum performance.

Typical achievable sensor module performance is displayed in Table 7. Users who require an absolute measurement with the maximum achievable accuracy are advised to re-calibrate the sensor module with a known air compound. For some environments, an interference response to siloxanes is of concern; however, the Renesas ZMOD4510 has been proven to be resistant against siloxanes. A maximum potential life-time exposure has been simulated in all ZMOD4510 operation modes by applying the chemicals D4 (Octamethylcyclotetrasiloxane) and D5 (Decamethylcyclopentasiloxane) in high concentration for several hundred hours.

Table 7. Typical ZMOD4510 Sensor Module Accuracy Achievable

Parameter	Conditions	Minimum	Typical	Maximum	Unit
Accuracy	Without additional calibration		±50		AQI
Consistency	Part-to-Part Variation		±50		AQI
Durability to Siloxanes	Change in sensitivity during 15,000 ppm-h exposure with D4 and D5		±8		%

6. Assembly Restrictions, Operation, Integration Notes and Storage

When implementing the ZMOD4510 in electrical circuit boards, a gas sensor module may react to chemicals during the assembly process and to outgassing components, such as resins from the printed circuit board (PCB) assembly. A standard soldering profile can be used to assemble the ZMOD4510 on the user's PCB and should fulfill the IPC/JEDEC J-STD-020C Standard ("Moisture/Reflow Sensitivity Classification for Non-hermetic Solid State Surface Mount Devices"). A typical lead-free reflow solder profile is shown in Figure 3. After assembly, an outgassing of the PCB and electronic components must be considered, especially when operating the sensor module at elevated temperatures. This will ultimately influence the sensor signal and accuracy of the Air Quality Index (AQI). A PCB heat treatment before assembling the ZMOD4510 is recommended. After the gas sensor module assembly, no coating, cleaning, or ultrasonic bath should be applied to the PCB. Also, in case sensor module parts are contaminated during assembly or storage, it can be cleaned after assembly by using the cleaning library provided with the firmware to remove any contamination of solder vapor from the MOx surface. In case the sensor module does not show full performance after a cleaning cycle, a change to the protection sticker package is recommended (see Ordering Information).

Store the sensor module in an antistatic metallic bag with a low VOC background after the sensor module is removed from its original packaging or the assembled PCB is populated. The optimal storage conditions are < 1ppm TVOC, < 100ppb O3, < 100ppb NO2, 10°C to 50°C, and humidity levels within 20% to 80%RH. If the sensor module is stored outside of these conditions for extended periods of time, the sensor module readings can exhibit a temporary offset. The sensor module can be reconditioned and brought back to its calibration state by operation for 24 hours to 48 hours in clean air.

To receive the Renesas Gas Sensor Guidelines with detailed information and on assembly, material outgassing, test and validation procedures, contact Renesas via the contact information on the last page.

Figure 3. Typical Solder Profile

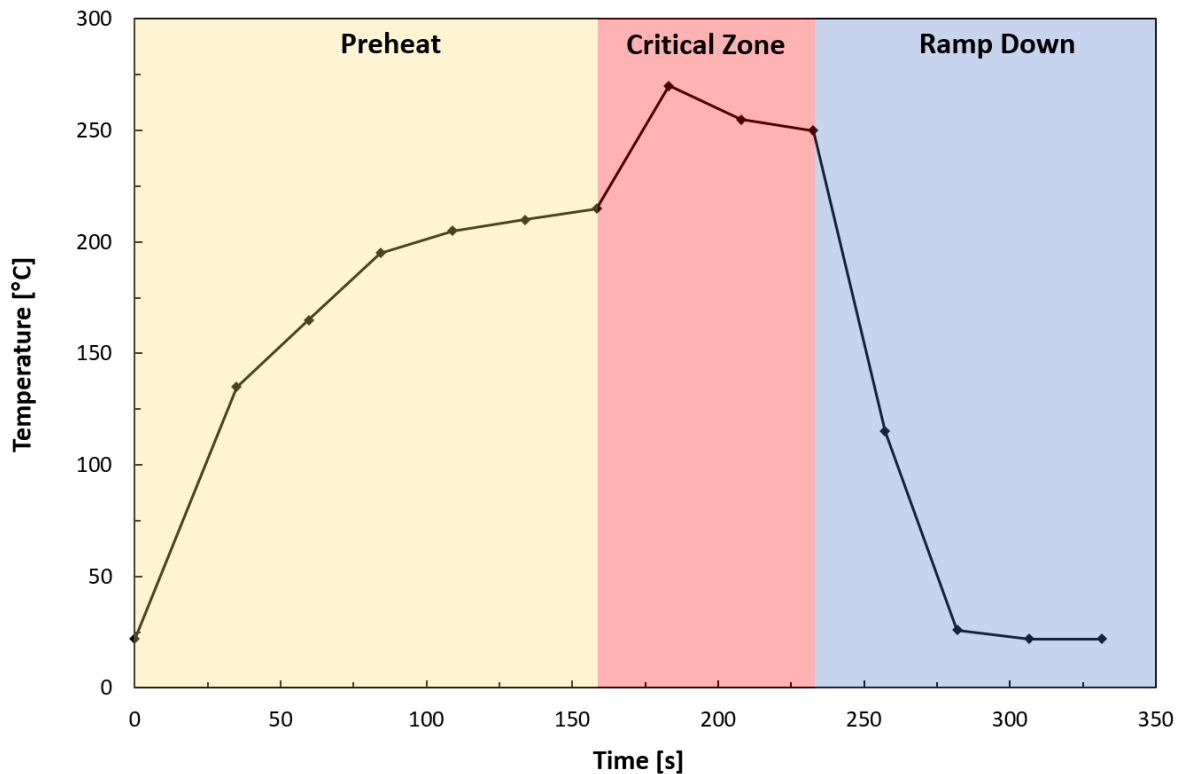

7. Test and Calibration

As a unique feature, all sampled gas sensor modules are fully tested during Renesas' final test. The final test parameters in Table 8 are applied for each ZMOD4510. All sensor modules are pre-stabilized in the final test although the user might see a small change in the module's raw signal during an initial warm-up phase during the first operation. The gas sensor module qualification is based on JEDEC (JESD47) and its subsequent standard (JESD22, JESD78 etc.); it has been tested for a lifetime of 5 years. Renesas has proven a MOx lifetime of over 15+ years in actual continuous operation in conditions without exposures to stressful environments.

Table 8. Final Test Parameters

Test	Test Object	Parameters	Test Results Saved in NVM?
Electrical	ASIC	Voltages, current consumption, frequencies, scan pattern	No
Electrical	Module	Calibration conditions, tracking ID, resistances	Yes
Gas	Module	Sensitivity parameters (slope and intercept) at stimulation with different gas concentrations	Yes
Gas	Module	Pre-stabilization	No

8. I2C Interface and Data Transmission Protocol

The I2C slave device interface supports various bus speeds: Standard Mode ($\leq 100\text{kHz}$) and Fast Mode ($\leq 400\text{kHz}$).

By default, the 7-bit slave address for the serial I2C data interface is set to 33_{HEX}. The implemented data transmission protocol is similar to the one used for conventional EEPROM devices. The register to read/write is selected by a register address pointer. This address pointer must be set during an I2C write operation. For read access a repeated START condition but no STOP condition should be sent. After transmission of a register, the address pointer is automatically incremented. A STOP condition ends the whole transmission. An increment from the address FF_{HEX} rolls over to 00_{HEX}.

For an example of the I2C data transmission protocol, see Figure 4. For information on I2C bus timing, see Figure 5. For I2C bus characteristics, see Table 9, which explains how to set up the interface. All other values are according to the I2C standard. Although the ZMOD4510 has an I2C interface, the user is not intended to modify any registers because a configuration change will affect the sensor module's performance, reliability, and accuracy. The API provided with the downloadable firmware package on the website manages all necessary sensor module communication.

To validate the general MCU-specific I2C read/write driver without the use of Renesas firmware, it is possible to write random values to registers 0x88 to 0x8B and read them afterwards. After this register testing, erase the testing code and reset the device by disconnecting the power supply; otherwise the device may not operate properly.

Figure 4. I2C Data Transmission Protocol

WRITE Access RAM

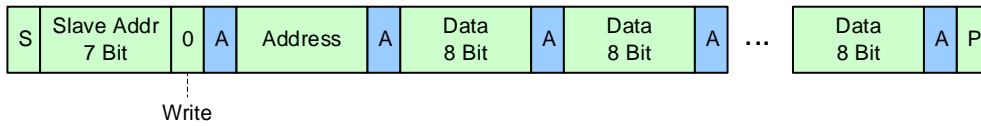

READ Access NVM and RAM

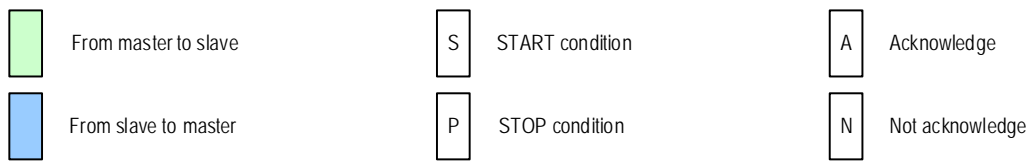
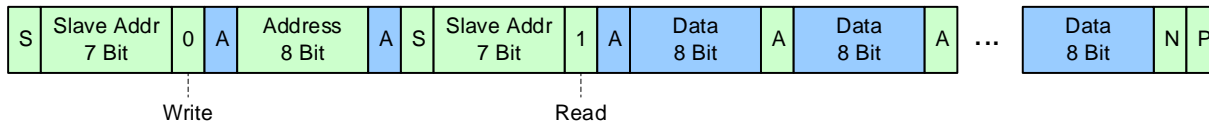

Figure 5. Bus Timing

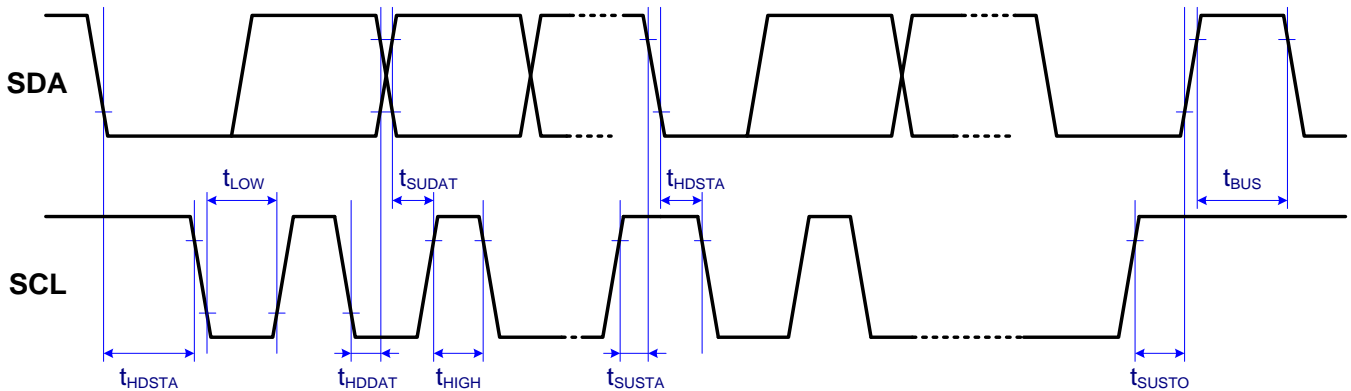

Table 9. Bus Timing Characteristics

Symbol	Parameter	Standard Mode	Fast Mode	Units
f _{SCL}	Maximum SCL clock frequency	100	400	kHz
t _{HDSTA}	Minimum START condition hold time relative to SCL edge	4		μs
t _{LOW}	Minimum SCL clock low width	4.7		μs
t _{HIGH}	Minimum SCL clock high width	4		μs
t _{SUSTA}	Minimum START condition setup time relative to SCL edge	4.7		μs
t _{HDDAT}	Minimum data hold time on SDA relative to SCL edge	0		μs
t _{SUDAT}	Minimum data setup time on SDA relative to SCL edge	0.1	0.1	μs
t _{SUSTO}	Minimum STOP condition setup time on SCL	4		μs
t _{BUS}	Minimum bus free time between stop condition and start condition	4.7		μs

9. Related Websites and Software

Visit the [ZMOD4510](#) and [ZMOD4510 Evaluation Kit](#) (ZMOD4510-EVK) product pages on the Renesas website to download software and the latest version of related documents, such as application notes, white papers, product briefs, and third-party reports.

Note that some documents require logging in with a free customer account, which can be set up under the “LOG IN” button on the website. Some downloads require an additional step to complete a request form that appears when the link is clicked.

If further support is needed for downloading, contact Renesas via the contact information on the last page.

10. Package Outline Drawings

The ZMOD4510's different packages are listed in Table 10.

Table 10. Package Options

Part Number	Version	Comment	Package Link
ZMOD4510AI1	Standard	Standard package	3.0 × 3.0 × 0.7 mm, 12-LGA
ZMOD4510AI2	Sticker	This package shipped with a sticker on top of the lid to protect sensor during assembly. Note, the sticker has to be removed after assembly.	
ZMOD4510AI3	Waterproof	This package uses a membrane to get IP67 rating.	3.0 × 3.0 × 0.9 mm, 12-LGA
ZMOD4510AI4	Waterproof + Sticker	This package uses a membrane to get IP67 rating and is shipped with a sticker on top of the lid to protect sensor during assembly. Note, the sticker has to be removed after assembly.	

11. Marking Diagram

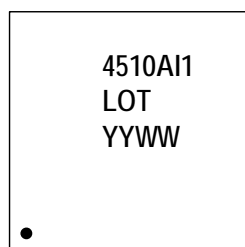

1. Line 1 is the truncated part number.
2. Line 2 – “LOT” denotes the assembly lot number.
3. Line 2 – “YYWW” are the last two digit of the year and week that the part was assembled.

12. Ordering Information

Part Number	Description and Package	MSL Rating	Carrier Type	Temp. Range
ZMOD4510AI1V	ZMOD4510 Sensor Module, 3.0 × 3.0 × 0.7 mm 12-LGA	3	Tray	-40° to +65°C
ZMOD4510AI1R	ZMOD4510 Sensor Module, 3.0 × 3.0 × 0.7 mm 12-LGA	3	Reel	-40° to +65°C
ZMOD4510AI2V	ZMOD4510 Sensor Module, 3.0 × 3.0 × 0.7 mm 12-LGA , shipped with removable protection sticker	3	Tray	-40° to +65°C
ZMOD4510AI2R	ZMOD4510 Sensor Module, 3.0 × 3.0 × 0.7 mm 12-LGA , shipped with removable protection sticker	3	Reel	-40° to +65°C
ZMOD4510AI3V	ZMOD4510 Sensor Module, 3.0 × 3.0 × 0.9 mm 12-LGA , IP67 rating	3	Tray	-40° to +65°C
ZMOD4510AI3R	ZMOD4510 Sensor Module, 3.0 × 3.0 × 0.9 mm 12-LGA , IP67 rating	3	Reel	-40° to +65°C
ZMOD4510AI4V	ZMOD4510 Sensor Module, 3.0 × 3.0 × 0.9 mm 12-LGA , shipped with removable protection sticker and IP67 rating	3	Tray	-40° to +65°C
ZMOD4510AI4R	ZMOD4510 Sensor Module, 3.0 × 3.0 × 0.9 mm 12-LGA , shipped with removable protection sticker and IP67 rating	3	Reel	-40° to +65°C
ZMOD4510-EVK-HC	ZMOD4510 Evaluation Kit including the ZMOD4510 Sensor Board, HiCom Communication Board (USB Interface) and Micro-USB Cable. The Gas Sensor Evaluation Software is available for download free of charge on ZMOD4510 Evaluation Kit product page.			

13. Glossary

Term	Description
ADC	Analog-to-Digital Converter
AOI	Air Quality Index
CDM	Charged Device Model
CM	Common Mode Generator
EPA	Environmental Protection Agency (USA)
HBM	Human Body Model
LGA	Land Grid Array
LV	Low Voltage
MCU	Microcontroller Unit
MOx	Metal Oxide
MSL	Moisture Sensitivity Level
Mux	Multiplexer
n.a.	Not Applicable
NO ₂	Nitrogen Dioxide
NVM	Nonvolatile Memory
O ₃	Ozone
POR	Power-On Reset
RH	Relative Humidity
SDA	Serial Data
SCL	Serial Clock
SSC	Sensor Signal Conditioner
TST	Test
TVOC	Total Volatile Organic Compounds

14. Revision History

Revision Date	Description of Change
June 30, 2021	<ul style="list-style-type: none"> • Added an explanation of EPA AQI and FAST AQI • Corrected the part numbers in Package Options
May 20, 2021	<ul style="list-style-type: none"> • Added OAQ 2nd Gen and Package options • Completed minor changes throughout
February 7, 2020	<ul style="list-style-type: none"> • Added ROHS compliance • Updated NVM data space • Updated on temperature measurements
September 9, 2019	Initial release.

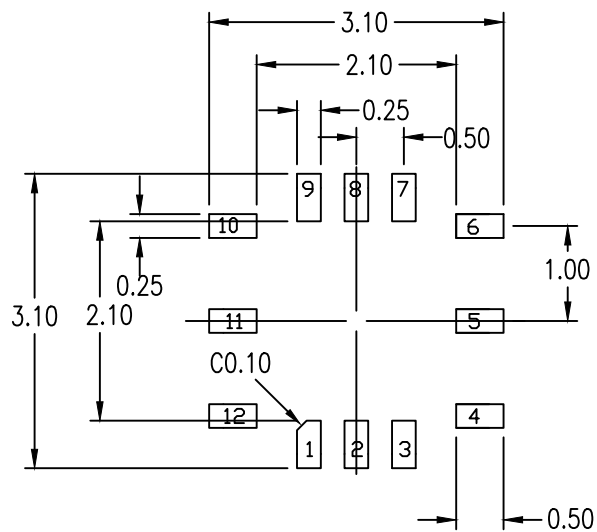

RECOMMENDED LAND PATTERN DIMENSION

NOTES:

1. ALL DIMENSION ARE IN MM. ANGLES IN DEGREES.
2. TOP DOWN VIEW. AS VIEWED ON PCB.
3. NSMD LAND PATTERN ASSUMED.
4. LAND PATTERN RECOMMENDATION PER IPC-7351B GENERIC REQUIREMENT FOR SURFACE MOUNT DESIGN AND LAND PATTERN.

Package Revision History

Date Created	Rev No.	Description
Sept 12, 2019	Rev 01.	Add Dimension on Gal Inlet Hole
Dec 17, 2019	Rev 02	Add Location Dimension Gal Inlet
Mar 10, 2021	Rev 03	Add Tolerance for Entire Body

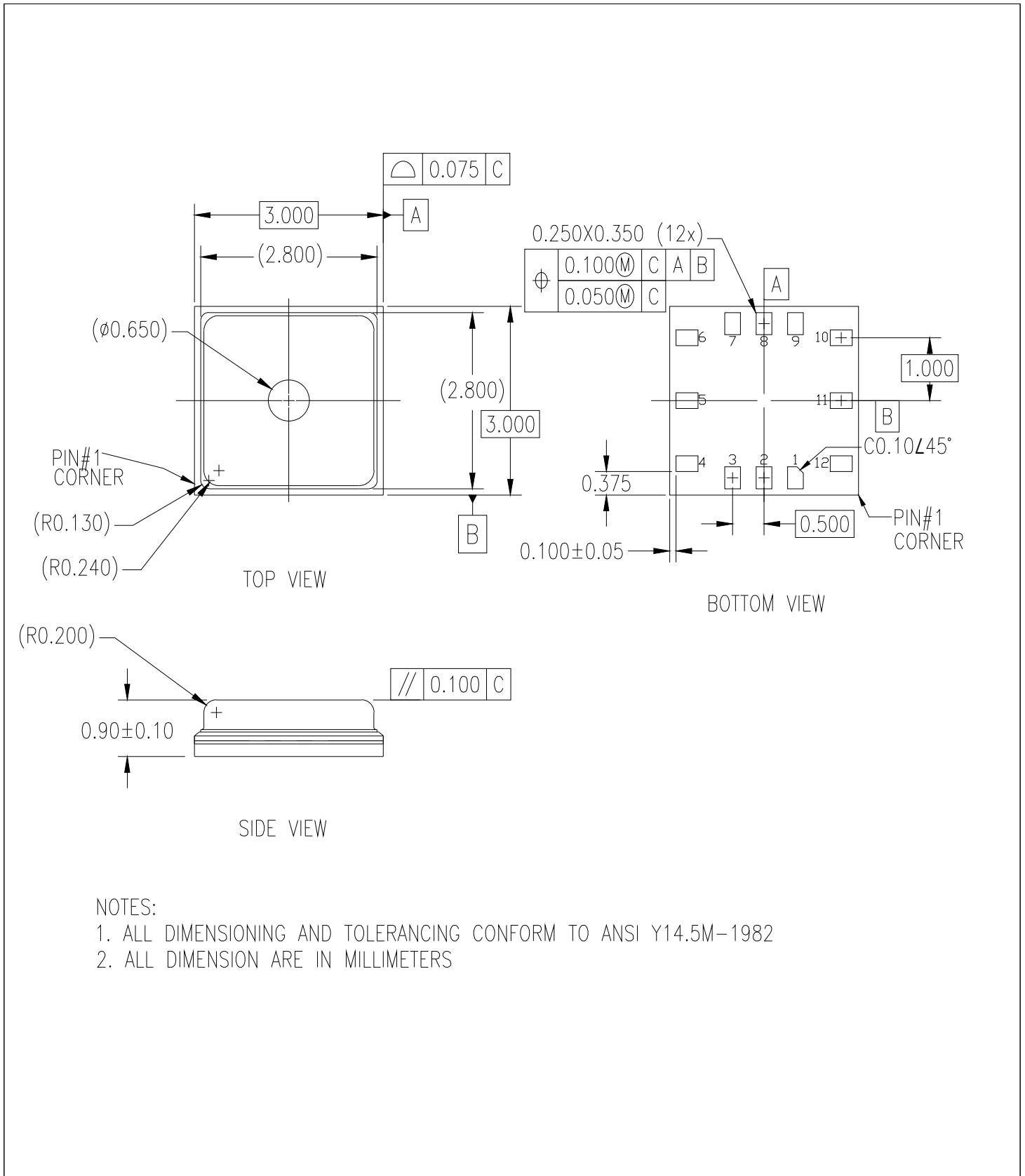

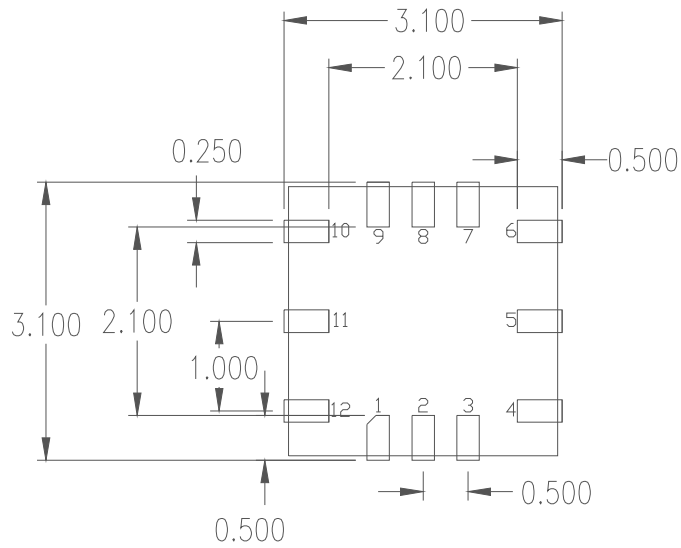

RECOMMENDED LAND PATTERN DIMENSION

NOTES:

1. ALL DIMENSION ARE IN MM. ANGLES IN DEGREES
2. TOP DOWN VIEW ON PCB
3. LAND PATTERN RECOMMENDATION PER IPC-7351B GENERIC REQUIREMENT FOR SURFACE MOUNT DESIGN AND LAND PATTERN

Date Created	Rev No.	Package Revision History
April 24, 2020	Rev 00	Initial release

IMPORTANT NOTICE AND DISCLAIMER

RENESAS ELECTRONICS CORPORATION AND ITS SUBSIDIARIES (“RENESAS”) PROVIDES TECHNICAL SPECIFICATIONS AND RELIABILITY DATA (INCLUDING DATASHEETS), DESIGN RESOURCES (INCLUDING REFERENCE DESIGNS), APPLICATION OR OTHER DESIGN ADVICE, WEB TOOLS, SAFETY INFORMATION, AND OTHER RESOURCES “AS IS” AND WITH ALL FAULTS, AND DISCLAIMS ALL WARRANTIES, EXPRESS OR IMPLIED, INCLUDING, WITHOUT LIMITATION, ANY IMPLIED WARRANTIES OF MERCHANTABILITY, FITNESS FOR A PARTICULAR PURPOSE, OR NON-INFRINGEMENT OF THIRD PARTY INTELLECTUAL PROPERTY RIGHTS.

These resources are intended for developers skilled in the art designing with Renesas products. You are solely responsible for (1) selecting the appropriate products for your application, (2) designing, validating, and testing your application, and (3) ensuring your application meets applicable standards, and any other safety, security, or other requirements. These resources are subject to change without notice. Renesas grants you permission to use these resources only for development of an application that uses Renesas products. Other reproduction or use of these resources is strictly prohibited. No license is granted to any other Renesas intellectual property or to any third party intellectual property. Renesas disclaims responsibility for, and you will fully indemnify Renesas and its representatives against, any claims, damages, costs, losses, or liabilities arising out of your use of these resources. Renesas' products are provided only subject to Renesas' Terms and Conditions of Sale or other applicable terms agreed to in writing. No use of any Renesas resources expands or otherwise alters any applicable warranties or warranty disclaimers for these products.

(Rev.1.0 Mar 2020)

Corporate Headquarters

TOYOSU FORESIA, 3-2-24 Toyosu,
Koto-ku, Tokyo 135-0061, Japan
www.renesas.com

Contact Information

For further information on a product, technology, the most up-to-date version of a document, or your nearest sales office, please visit:
www.renesas.com/contact/

Trademarks

Renesas and the Renesas logo are trademarks of Renesas Electronics Corporation. All trademarks and registered trademarks are the property of their respective owners.