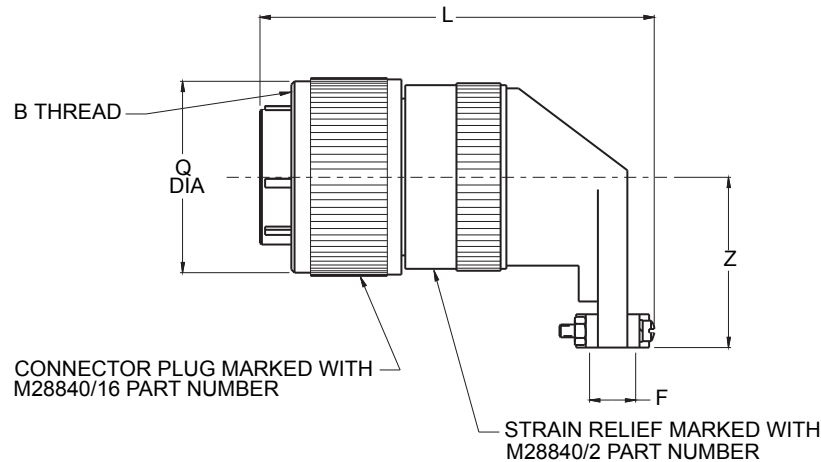

HOW TO ORDER:

GLENAIR P/N: 901-018 NF 25 - 1 P 1
 MILITARY P/N: M28840/18 A G 1 P 1

BASIC PART NUMBER KEY POSITION (SEE MIL-C-28840)
 CLASS CODE (SEE MIL-C-28840) CONTACT STYLE (SEE MIL-C-28840)
 SHELL SIZE (SEE ABOVE) INSERT ARRANGEMENT (SEE MIL-C-28840)

NOTES:

- INTERPRET PER MIL-STD-100.
- SEE MIL-C-28840 FOR ADDITIONAL DESIGN DETAILS.
- GLENAIR NF = CLASS A
GLENAIR ZU = CLASS B
- BAG AND TAG WITH M28840/18 PART NUMBER

TABLE I: CONNECTOR DIMENSIONS

MILITARY SHELL SIZE	SHELL SIZE	B THREAD CLASS 2B	F CABLE ENTRY		L MAX.	Q MAX.	Z MAX.	MAX O.D. OVER REAR CLAMPS
			OPEN	CLOSED				
A	11	.750-.1P-.2L-D.S.	.286 (7.3)	.177 (4.5)	2.438 (61.9)	1.028 (26.1)	.929 (23.6)	.832 (21.1)
B	13	.875-.1P-.2L-D.S.	.286 (7.3)	.177 (4.5)	2.438 (61.9)	1.141 (29.0)	.929 (23.6)	.832 (21.1)
C	15	1.062-.1P-.2L-D.S.	.416 (10.6)	.250 (6.4)	2.438 (61.9)	1.263 (32.1)	1.056 (26.8)	.989 (25.1)
D	17	1.125-.1P-.2L-D.S.	.476 (12.1)	.291 (7.4)	2.688 (68.3)	1.387 (35.2)	1.233 (31.3)	1.094 (27.8)
E	19	1.312-.1P-.2L-D.S.	.626 (15.9)	.348 (8.8)	2.812 (71.4)	1.513 (38.4)	1.296 (32.9)	1.319 (33.5)
F	23	1.500-.1P-.2L-D.S.	.831 (21.1)	.429 (10.9)	2.938 (74.6)	1.703 (43.3)	1.358 (34.5)	1.557 (39.5)
G	25	1.625-.1P-.2L-D.S.	.956 (24.3)	.523 (13.3)	3.062 (77.8)	1.825 (46.4)	1.420 (36.1)	1.653 (42.0)
H	29	1.812-.1P-.2L-D.S.	1.081 (27.5)	.643 (16.3)	3.188 (81.0)	2.143 (54.4)	1.634 (41.5)	1.819 (46.2)
J	33	2.000-.1P-.2L-D.S.	1.187 (30.1)	.704 (17.9)	3.375 (85.7)	2.329 (59.2)	1.859 (47.2)	2.020 (51.3)