

Features

- Plastic package has Underwriters Laboratory Flammability Classification 94V-0
- For surface mounted applications
- High current capability
- Very low forward voltage drop
- Epitaxial construction
- Metal-Semiconductor junction with guardring
- For use in low voltage, high frequency inverters, Free-wheeling, and polarity protection applications

EC76SS5-2B~EC76SS5-6B



DO-214AA(SMB)

Applications

- Case : JEDEC DO-214AA(SMB) molded plastic
- Polarity : Indicated by cathode band
- Weight : 0.003 ounce, 0.093 gram

Maximum Ratings and Electrical Characteristics

Ratings at 25°C ambient temperature unless otherwise specified. Single phase, half wave, 60Hz, resistive or inductive load. For capacitive load, derate current by 20%

Parameter	Symbol	EC76SS5-2B	EC76SS5-4B	EC76SS5-6B	Unit
Maximum repetitive peak reverse voltage	VRRM	20	40	60	V
Maximum RMS voltage	VRMS	14	28	42	V
Maximum DC blocking voltage	VDC	20	40	60	V
Maximum average forward rectified current @TL=100°C	IF(AV)	5.0			A
Peak forward surge current, 8.3ms single half sine-wave superimposed on rated load (JEDEC Method)	IFSM	150.0			A
Maxmum forward voltage at 3.0ADC @TJ =25°C @TJ =100°C	VF	0.50	0.60	0.70	V
Maximum DC reverse current at rated DC blocking voltage @TJ =25°C @TJ =100°C	IR	0.5 20			mA
Typical junction capacitance (Note 1)	CJ	96			pF
Typical thermal resistance (Note 2,3)	RθJL RθJA	25 85			°C/W
Operating junction temperature range	TJ	-55 to +125			°C
Storage temperature range	TSTG	-55 to +150			°C

- Notes: 1. Measured at 1.0MHz and applied reverse voltage of 4.0V DC.
 2. Thermal Resistance Junction to Lead.
 3. Thermal Resistance Junction to Ambient.

Typical Performance Curves

FIG.1: FORWARD CURRENT DERATING CURVE

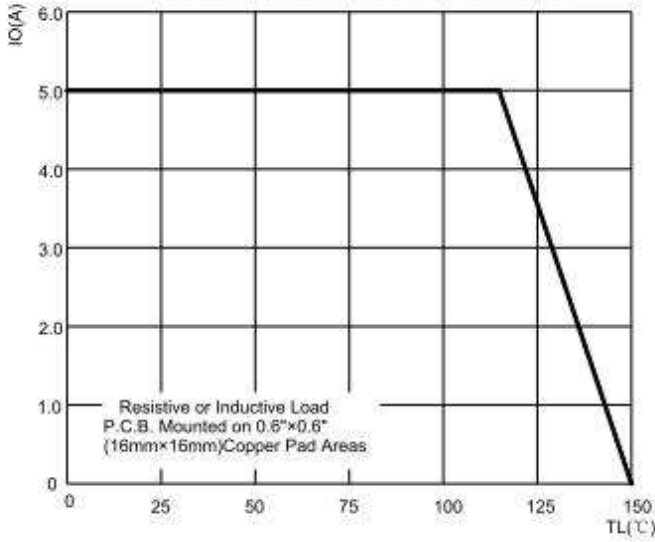

FIG.2: MAXIMUM NON-REPETITIVE FORWARD URGE CURRENT

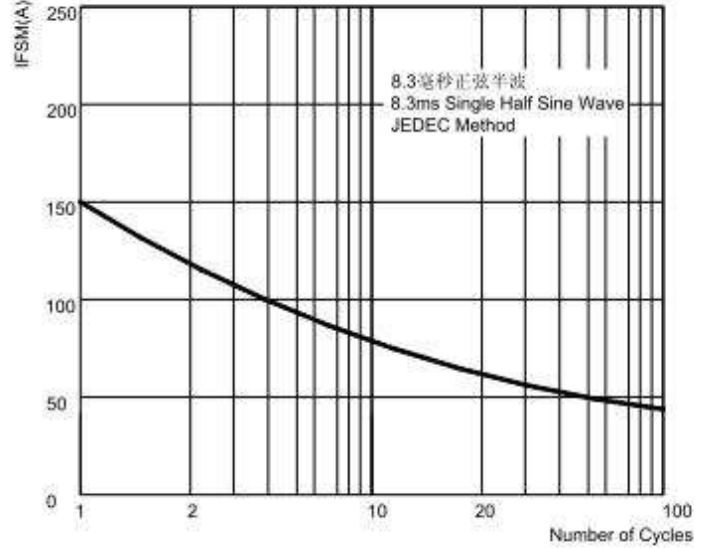

FIG.3: TYPICAL FORWARD CHARACTERISTICS

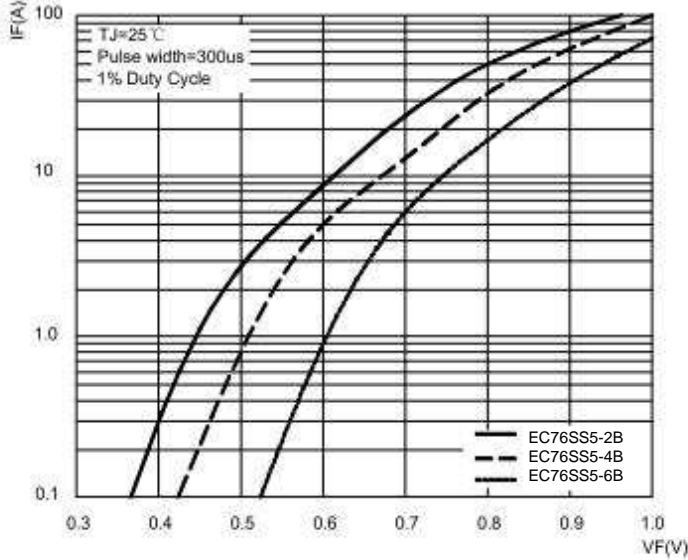
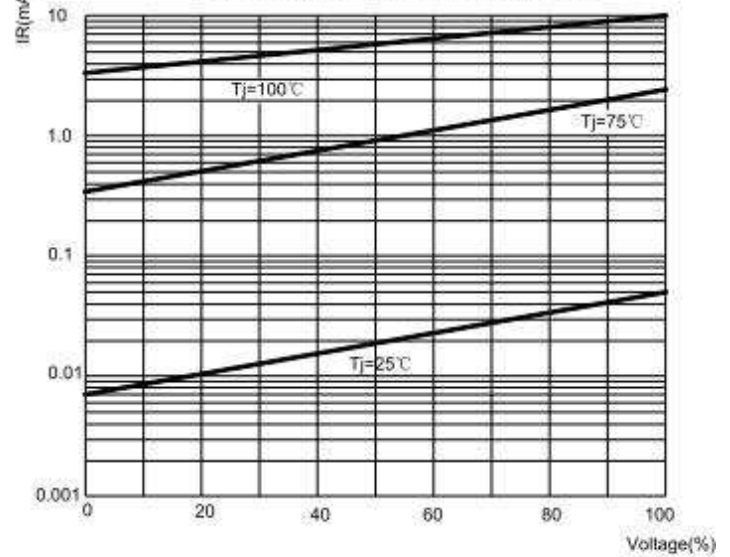
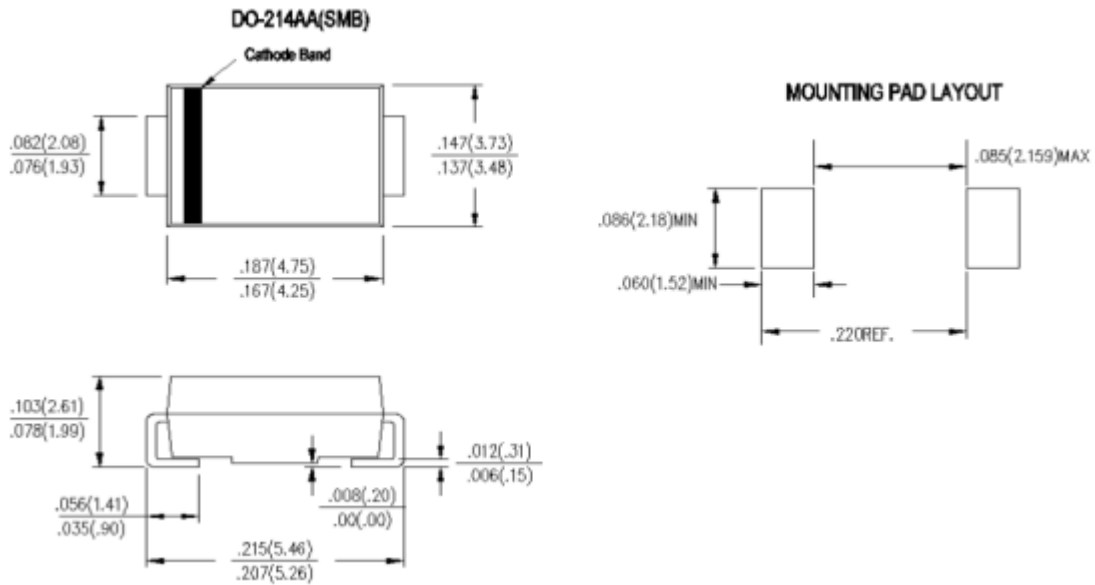

FIG.4: TYPICAL REVERSE CHARACTERISTICS



Product Dimension



Device	Package	Net Weight	Carrier	Quantity	HSF Status
EC76SS5-XB	DO-214AA(SMB)	0.093g	Tape & Reel	3000pcs/reel	RoHS compliant