

Helping Customers Innovate, Improve & Grow



The OX-407 is a low g-sensitivity ovenized crystal oscillator in a compact dual inline package (DIP) enclosure. Designed for applications that require excellent dynamic phase noise from 10Hz to 2kHz. The OX-407 offers g-sensitivity as low as 0.07 ppb/g, and a static noise floor below -150 dBc/Hz at 100 kHz offsets, with a temperature stability of 100 ppb.

### Features

- g-sensitivity as low as 0.07 ppb/g
- -150 dBc/Hz at 100kHz offset
- Standard frequencies - 10, 12.5, 20, 25, 40 and 50 MHz
- Dip package (14x 20 mm)
- Temperature Stability 100 ppb -40 to 70°C

### Applications

- Military Radar
- Instrumentation and Test Equipment
- Missile Systems
- Signal Intelligence

### Performance Specifications

Parameter	Min	Typ	Max	Units	Condition
<b>Frequency Stabilities<sup>1</sup></b>					
vs. operating temperature range (from nominal frequency)	-0.1		+0.1	ppm	-40 to 70°C
vs. supply voltage change	-0.05		+0.05	ppm	at time of shipment, nominal EFC Vs ± 5%
vs. aging / 1 year			±0.5	ppm	
<b>Supply Voltage (Vs)</b>					
Supply voltage	4.75	5.0	5.25	VDC	
	3.15	3.3	3.45	VDC	
Power at Warm Up			3	W	all temperatures
Power steady state			1W		at 25 C

## Performance Specifications

Parameter	Min	Typ	Max	Units	Condition
<b>RF Output</b>					
Signal	HCMOS				
Load		15		pF	
Signal Level (Vol)			0.1*Vs	V	
Signal Level (Voh)	0.9*Vs			V	
Rise/Fall Time			5	ns	@ nominal Load and 10% to 90% of waveform
Duty cycle	40	50	60	%	@ nominal Load and @ 50% level
Signal	Sinewave				
Output Power	0			dBm	50 ohms
Harmonics			-20	dBc	50 ohms
<b>Electronic Frequency Control (EFC)</b>					
Tuning Range (options A, C)	Fixed; No adjust				
Tuning Range (options B, D)	±5.0		±12	ppm	
Tuning Slope	Positive				
Control Voltage Range	0.0		Vs	VDC	
Freq. control input impedance	10			kohm	
<b>Additional Parameters<sup>1</sup></b>					
Phase Noise (@ 40 MHz - no vibration)		-84 -114 -134 -145 -150		dBc/Hz dBc/Hz dBc/Hz dBc/Hz dBc/Hz	10 Hz 100 Hz 1 kHz 10 kHz 100 kHz
g-sensitivity		0.2		ppb/g	per axis (ordering code A and B)
			0.07	ppb/g	per axis (ordering code C and D) parts 100% tested with 100 Hz sine vibration
Shock					MIL-STD-883G; Method 2002.4; Condition D
Vibration Sine					MIL-STD-202G, METHOD 204D, Test Condition D
Thermal Cycling					MIL-STD-202, METHOD 107, Test Condition A
<b>Absolute Maximum Ratings</b>					
Supply voltage (Vs)			6.0	V	Damage will occur beyond this level
Control Voltage	0		Vs	V	
Operable temperature range	-45		+90	°C	
Storage temperature range	-55		+105	°C	

# Outline Drawing

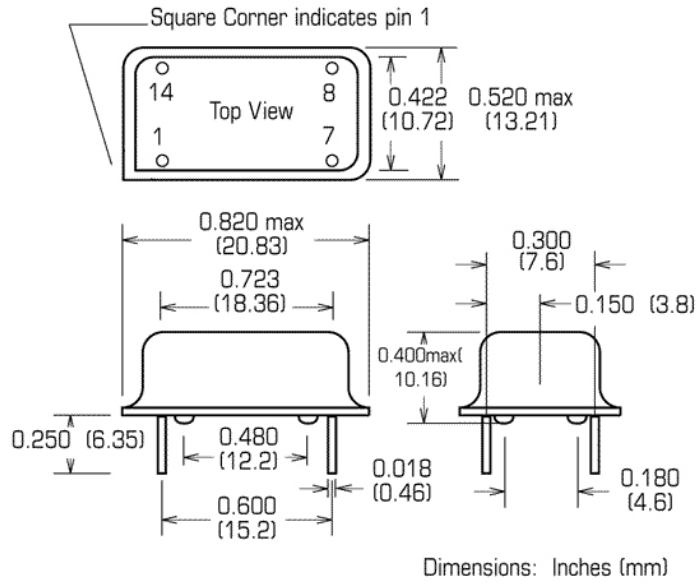

Code	Height "H"	Pin Length "L" Min
0	11.0	5.0
Pin Connections		
1	Electronic Frequency Control (EFC)	
7	Ground (case)	
8	Output	
14	Supply Voltage (Vs)	

[Dimensions in mm]

## Ordering Information

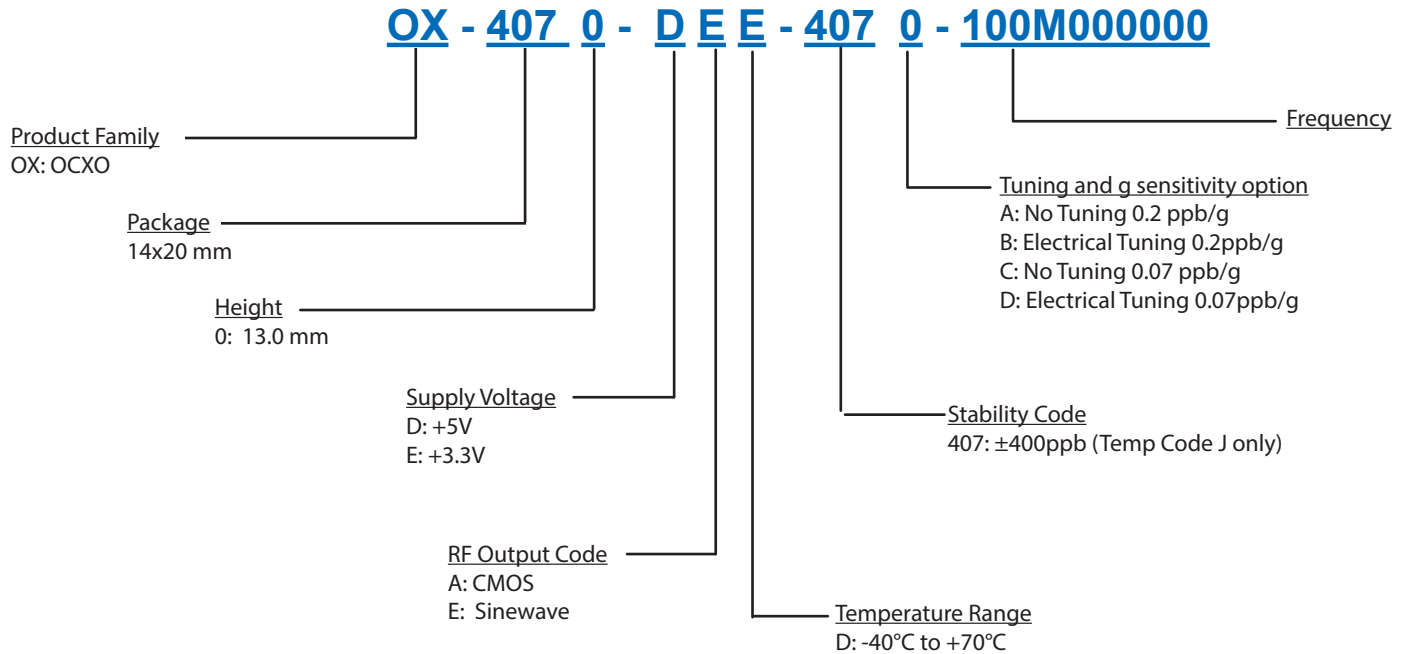

### Notes:

1. Unless otherwise stated, all values are valid after warm-up time and refer to typical conditions for supply voltage, frequency control voltage, load, and temperature (25°C).

## For Additional Information, Please Contact

### USA:

Vectron International  
267 Lowell Road, Unit 102  
Hudson, NH 03051  
Tel: 1.888.328.7661  
Fax: 1.888.329.8328

### Europe:

Vectron International  
Landstrasse, D-74924  
Neckarbischofsheim, Germany  
Tel: +49 (0) 3328.4784.17  
Fax: +49 (0) 3328.4784.30

### Asia:

Vectron International  
68 Yin Cheng Road(C), 22nd Floor  
One LuJiaZui  
Pudong, Shanghai 200120, China  
Tel: +86 21 6194 6886  
Fax: +86 21 6194 6699

### Disclaimer

Vectron International reserves the right to make changes to the product(s) and or information contained herein without notice. No liability is assumed as a result of their use or application. No rights under any patent accompany the sale of any such product(s) or information.

Rev:05112016dmc