

## LINECARD PROTECTION BY OVERVOLTAGE AND OVERCURRENT WITH A CLP270M

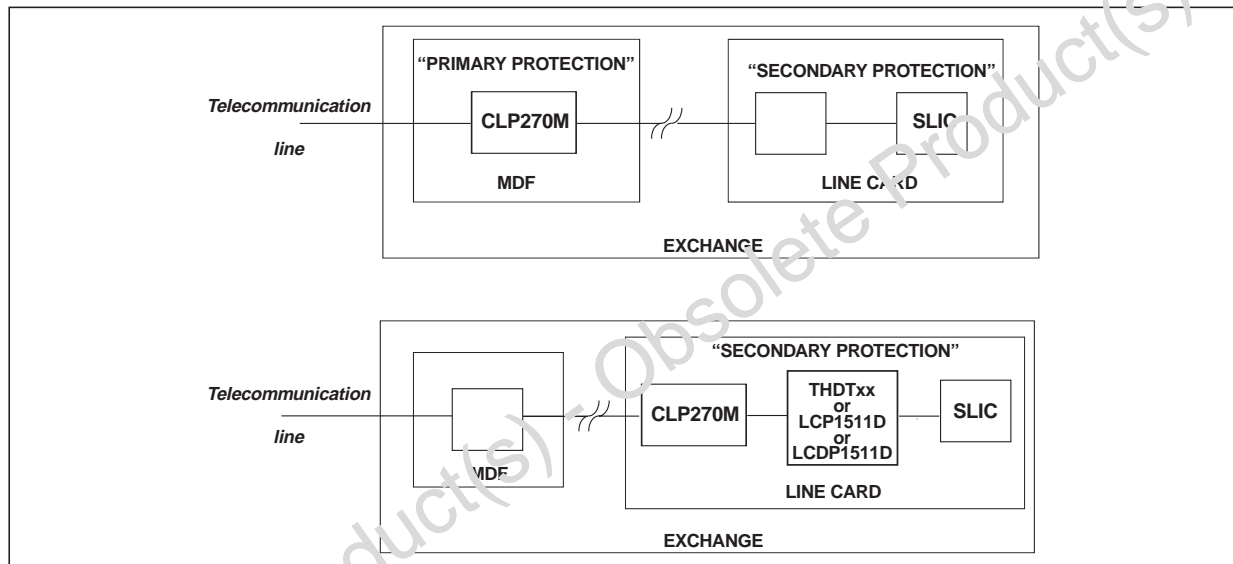
P.Merceron / A.Bremond

### INTRODUCTION

This device includes a primary protection level and is suitable for main distribution frames and line cards. This protection concept is explained and, in addition, the CLP270M performances are analysed when facing different surges as described in the BELLCORE GR 1089 recommendations.

Figure 1 is a simplified block diagram of a subscriber line protection that is commonly used.

**Fig. 1:** Subscriber line protection topology



This shows two different topologies :

- A “primary protection” located on the Main Distribution Frame (MDF) eliminates coarsely the high energy environment and disturbances (lightning transients and AC power mains disturbances)
- A “secondary protection” located on the line card includes a primary protection level (first stage) and a residual protection (second stage) which eliminates finely the remaining transients that have not been totally suppressed by the first stage.

# APPLICATION NOTE

## STMICROELECTRONICS CLP270M CONCEPT

### 1. Evolution of the SLIC protection

Over the years, the silicon protection performances have considerably changed.

The first generation of products like SMTHBTxx and SMTHDTxx offered fixed overvoltage protection against surges on either TIP or RING line in four packages.

The following generation like THBTxx and THDTxx still offered fixed overvoltage protection against surges on both TIP and RING lines in two packages.

The next step was the introduction of the LCP devices which brought the advantage of full programmable voltage.

Today, the CLP270M combines the features of all the previous generations. In addition to that, it offers an overcurrent detection when operating in speech mode and also a Failure Status output signal.

The figure 2 summarizes the firing modes of the CLP270M which basically holds the SLIC inside its correct voltage and current values.

Fig. 2: Line card protection

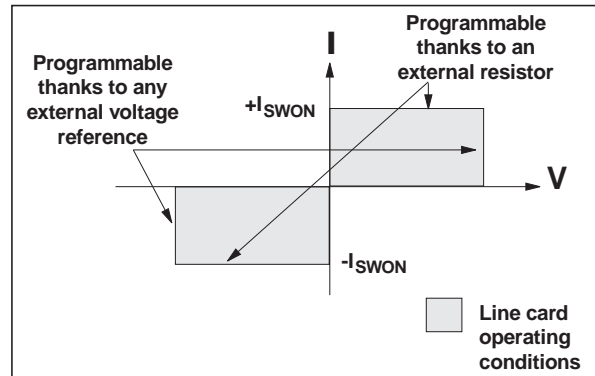
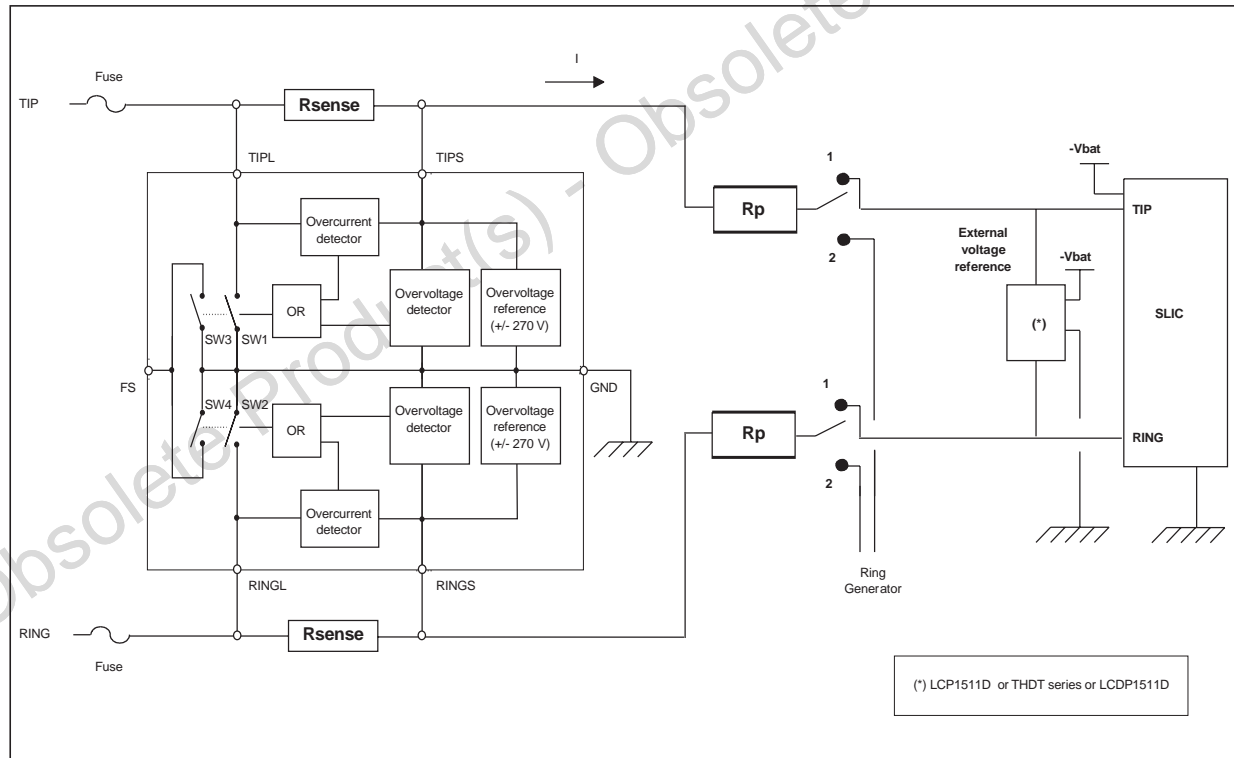


Fig. 3 : CLP270M in line card



## 2. Application circuit: CLP270M in line card

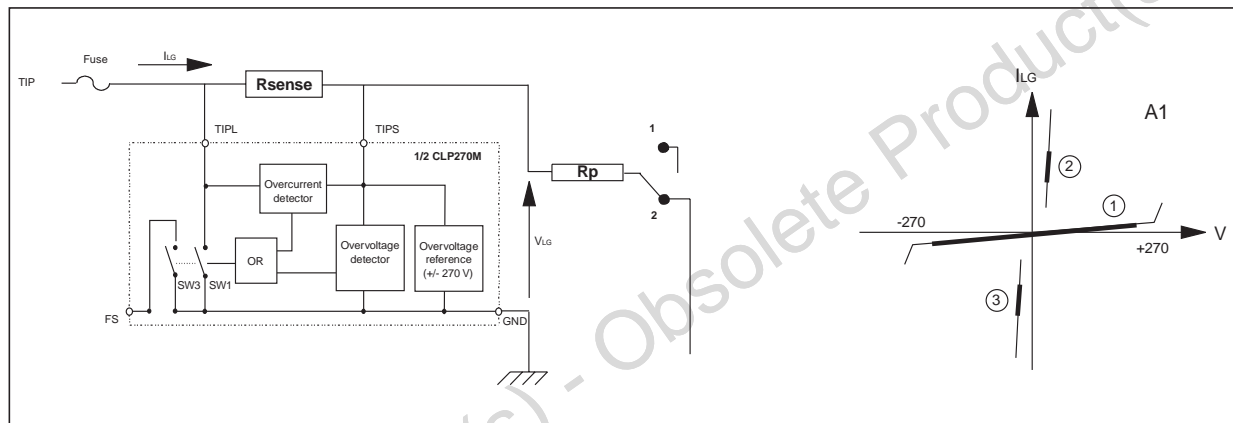
Figure 3 shows the topology of a protected analog subscriber line at the exchange side. The CLP270M is connected to the ring relay via two balanced  $R_p$  resistors, and to the Subscriber Line Interface Circuit. A second device is located near the SLIC : it can be either a LCP1511D, a THDT series or a LCDP1511D.

These two devices are complementary and their functions are explained below :

- The first stage based on CLP270M manages the high power issued from the external surges. When used in ringing mode, the CLP270M operates in voltage mode and provides a symmetrical and bidirectional overvoltage protection at  $\pm 270$  V on both TIP and RING lines. When used in speech mode, the CLP270M operates in current mode and the activation current of the CLP270M is adjusted by  $R_{sense}$ .
- The second stage is the external voltage reference device which defines the firing threshold voltage during the speech mode and also assumes a residual power overvoltage suppression. This protection stage can be either a fixed or programmable breakover device. The THDTxx family acts as a fixed breakover device while the LCP1511D or the LCDP1511D operates as a programmable protection.

Thanks to this topology, the surge current in the line is reduced after the CLP270M. Because the remaining surge energy is low, the power ratings of  $R_p$ , the ring relay contacts and the external voltage reference circuit can be downsized. This results in a significant cost reduction.

**Fig. 4:** Switching by voltage during ringing mode.



## 3. Ringing mode

In ringing mode (Ring relay in position 2), the only protection device involved is the CLP270M.

In normal conditions, the CLP270M operates in region 1 of **A1** curve, and is idle.

If an overvoltage occurring between TIP (or RING) and GND reaches the internal overvoltage reference ( $\pm 270$  V), the CLP270M acts and the line is short-circuited to GND. At this time the operating point moves to region 2 for positive surges (region 3 for negative surges). Once the surge current falls below the switch off current  $I_{SWOFF}$ , the device returns to its initial state (region 1).

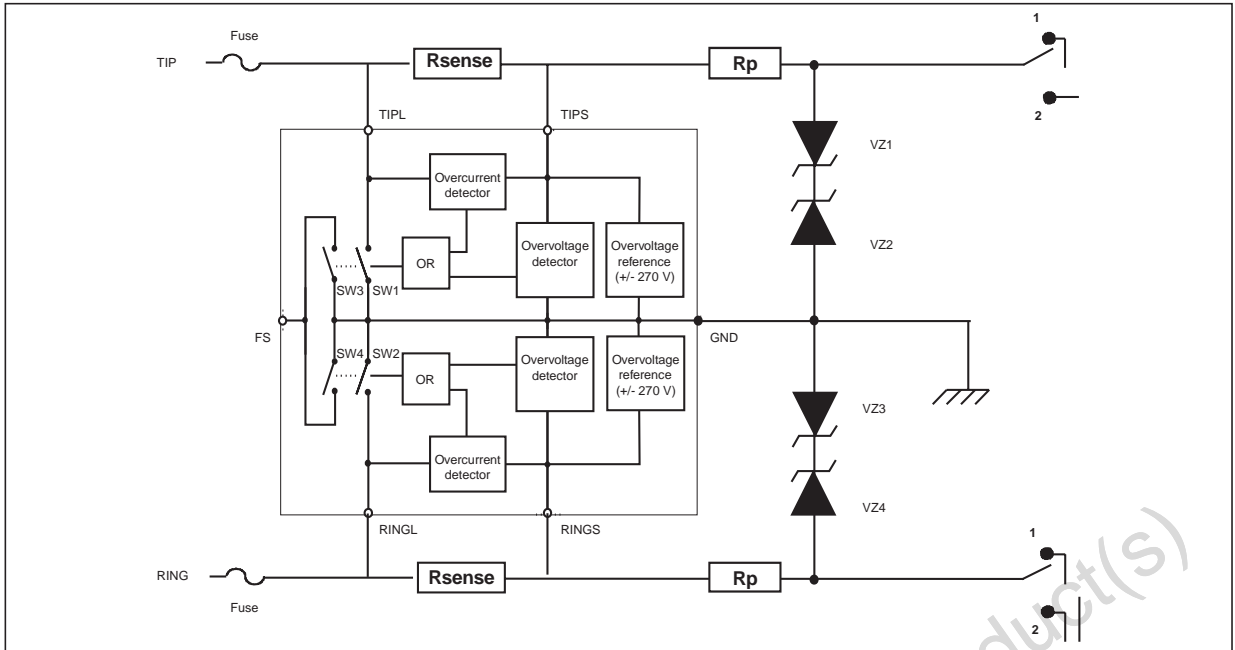
For surges occurring between TIP and RING, the CLP270M acts in the same way. This means that the CLP270M ensures a tripolar protection.

When used alone, the CLP270M acts at the internal overvoltage reference level ( $\pm 270$  V). Furthermore, it is possible to adjust this threshold level to a lower voltage by using:

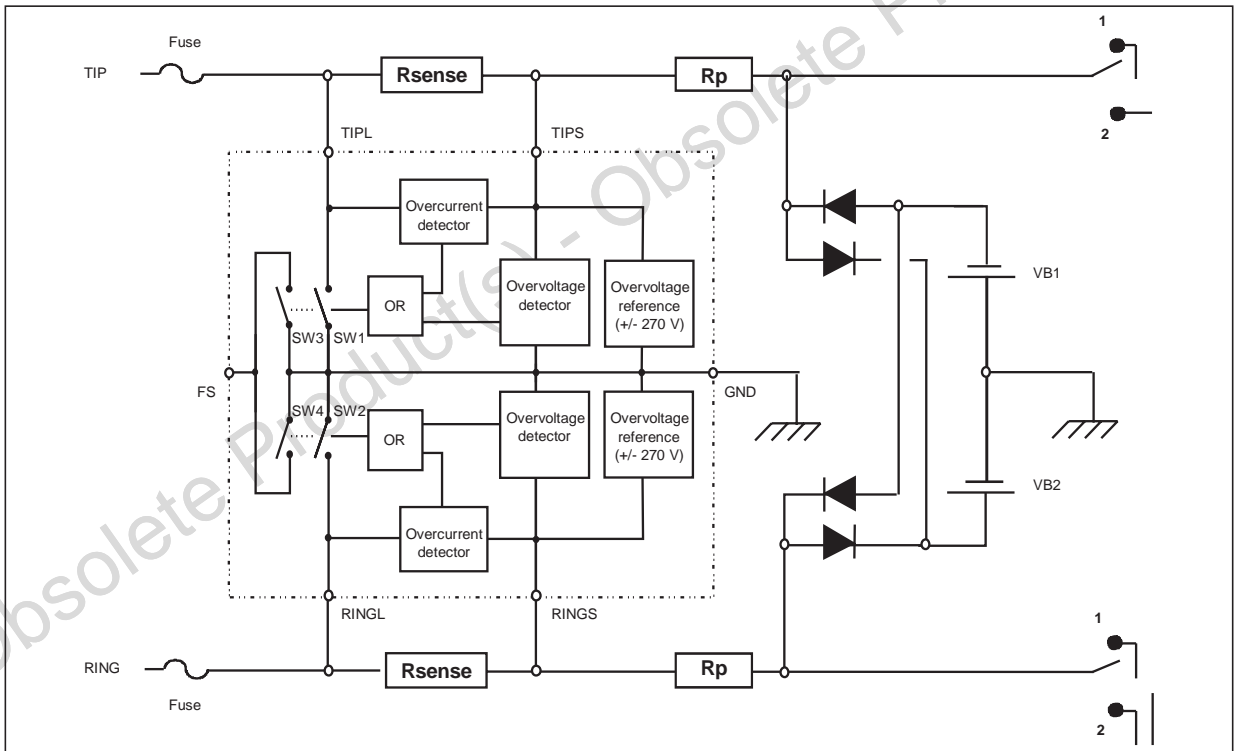
- up to 4 fixed external voltage reference ( $V_{Z1}$  to  $V_{Z4}$ ) (see fig. 5a, here-below).
- external reference supplies,  $V_{b1}$  and  $V_{b2}$  (see fig. 5b, on next page).

**APPLICATION NOTE**

**Fig. 5a:** Method to adjust the reference voltage.



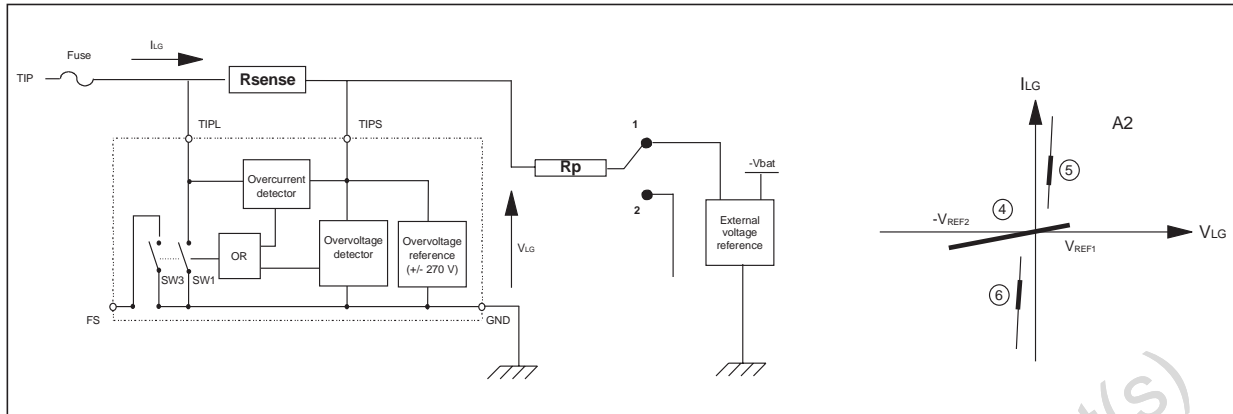
**Fig. 5b:** Method to adjust the reference voltage.



4. Speech mode

In speech mode (Ring relay in position 1), the protection is provided by the combination of both CLP270M and the external voltage reference device (see figure 6)

Fig. 6: Switching by current during speech mode.



In normal conditions, the working point of this circuit is located in region 4 of A2 curve : the CLP270M is idle. When a surge occurs on the line, the external voltage reference device clamps at GND or  $-V_{bat}$  respectively for positive and negative surges.

This generates a current which is detected by  $R_{sense}$  and causes the protection to act : the line is short-circuited to GND.

The operating point moves to region 5 for positive surges or region 6 for negative surges.

Once the surge current falls below the switching-off current  $I_{SWOFF}$ , the CLP270M returns to its initial state (region 4).

The choice of the switching-on currents is function of the  $R_{sense}$  resistors.

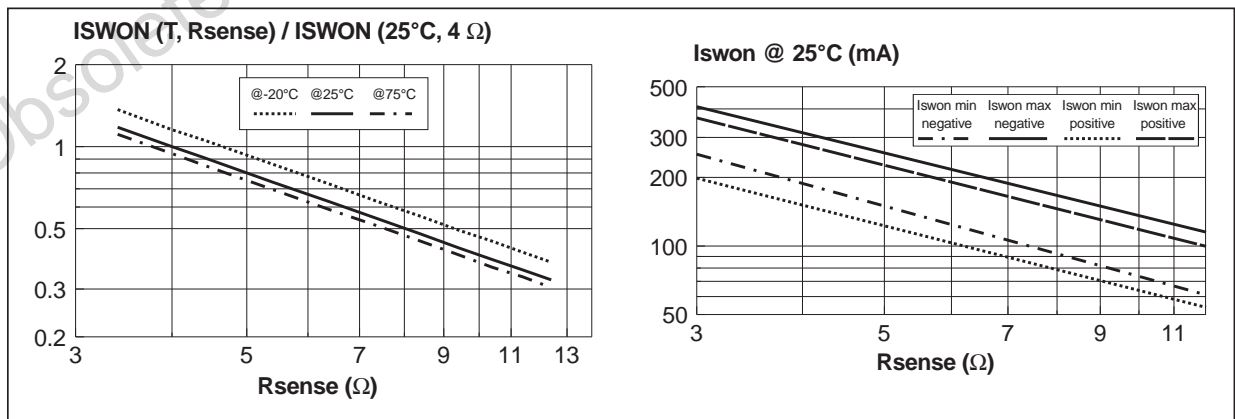
In normal operating condition the current (typically below  $-100\text{ mA}$ ) should not activate the protection device CLP270M. Therefore the level of activation has to be chosen just above this limit ( $-200\text{ mA}$ ). This level is adjusted through  $R_{sense}$ .

Figures 7a and 7b enable the designers to choose the right  $R_{sense}$  value.

Example:

The choice of  $R_{sense} = 4\ \Omega$  ensures a negative triggering of  $-190\text{ mA}$  min and  $-320\text{ mA}$  max. In this case, the positive triggering will be  $150\text{ mA}$  min and  $280\text{ mA}$  max.

Fig. 7a and 7b: Switching-on current versus  $R_{sense}$ .



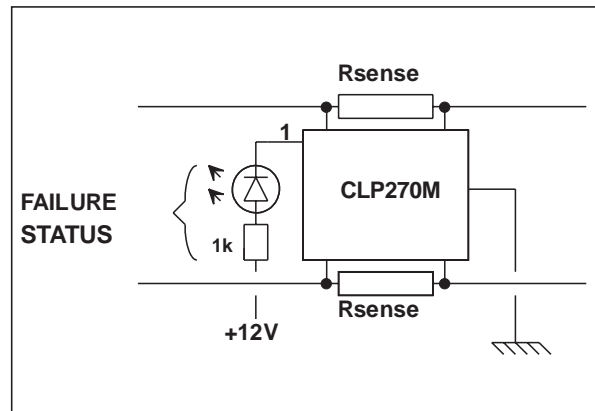
## APPLICATION NOTE

### 5. Failure Status

The CLP270M has an internal feature that allows the user to get a Failure Status (FS) indication. When the CLP270M is short-circuiting the line to GND, a signal can be managed through pin 1. This signal can be used to turn a LED on in order to provide a surge indication. It may also be used with a logic circuitry to count the number of disturbances appearing on the lines.

If a surge exceeding the maximum ratings of the CLP270M occurs on the line, the device will fail in a short-circuit state.

**Fig. 8:** Failure Status circuit and diagnostic.

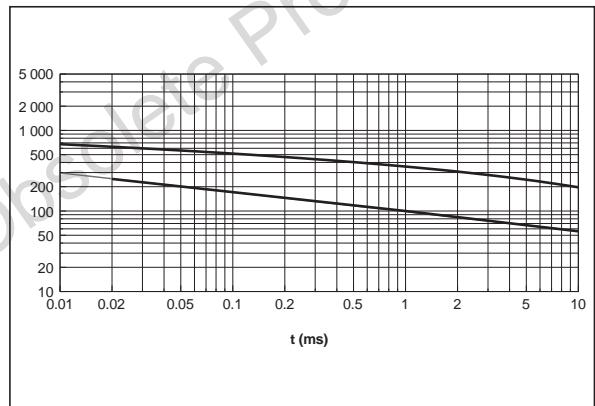


**Fig. 9 :** Operation limits and destruction zone of the CLP270M.

The figure 9 shows two different curves :

- The lower one indicates the maximum guaranteed working limits of the CLP270M.

The upper curve shows the limit above which the CLP270M is completely destroyed . In this case, the Fail Diagnostic pin is on.



## CLP270M TEST RESULTS ACCORDING TO BELLCORE 1089 REQUIREMENTS

### 1. BELLCORE GR-1089-CORE requirements:

Tables 1 and 2 summarize the lightning surges required by the bellcore 1089.

Tables 1 to 6 summarize the surge needs defined by Bellcore regarding both lightning and AC power fault. In case of first level test, the equipment under test shall be operating after the surge. For the second level tests, the equipment under test may be damaged, but no fire or electrical safety hazard may occur.

**Table 1:** First level lightning surge.

Surge	Minimum peak voltage (volts)	Minimum peak current per conductor (Amps)	Maximum rise / Minimum decay time for voltage and current ( $\mu$ s)	Repetitions, each polarity	Test connections per table 4.1
1	+/- 600	100	10/1000	25	A
2	+/- 1000	100	10/360	25	A
3	+/- 1000	100	10/1000	25	A
4	+/- 2500	500	2/10	10	B
5	+/- 1000	25	10/360	5	B

**Table 2:** Second level lightning surge.

Surge	Minimum peak voltage (volts)	Minimum peak current per conductor (Amps)	Maximum rise / Minimum decay time for voltage and current ( $\mu$ s)	Repetitions, each polarity	Test connections per table 4.1
1	+/- 5000	500	2/10	1	B

**Table 3:** First level AC power fault (table 4-7 of GR-1089-CORE issue 2, december 1997).

Test	Voltage ( $V_{RMS}$ )	Short circuit current per conductor (Amps)	Duration	Primary protection	Test connections per table 4.1
1	50	0.33	15 minutes	Removed	A
2	100	0.17	15 minutes	Removed	A
3	200, 400 and 600	1 (at 600V)	60 1 s application of each voltage	Removed	A
4	1000	1	60 1s applications	Operative protector in place	B
5	see figure 4-3	see figure 4-3	60 5s applications	Removed	see figure 4-3
6	600	0.5	30s	Removed	A
7	600	2.2	2s	Removed	A
8	600	3	1s	Removed	A
9	1000	5	0.5s	Operative protector in place	B

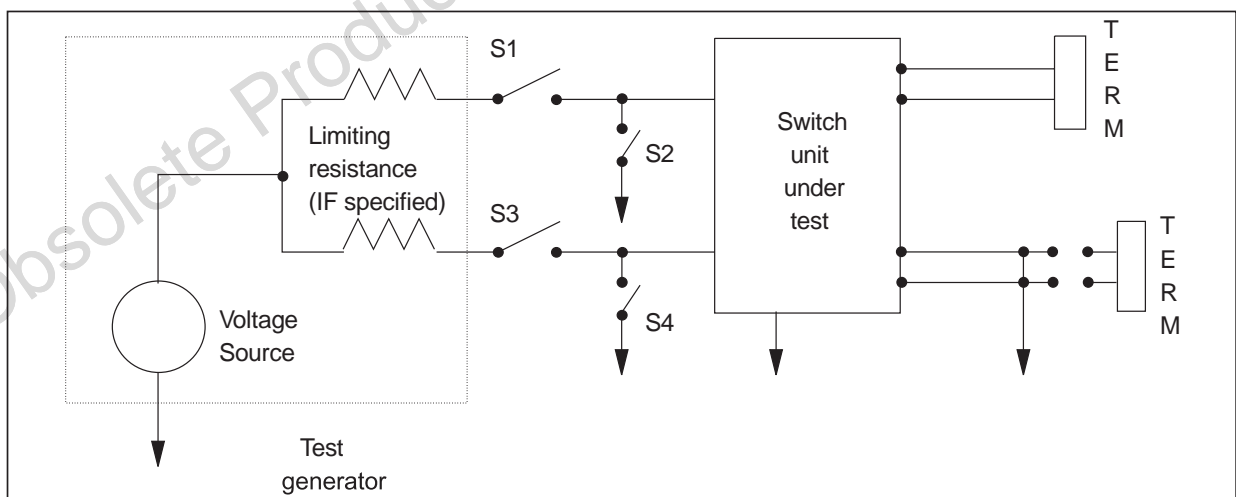
## APPLICATION NOTE

**Table 4:** Second level AC power fault (table 4-8 of GR-1089-CORE issue 2, december 1997).

Test	Test for	Voltage (V <sub>RMS</sub> )	Short circuit current per conductor (Amps)	Duration	Test connections per table 4.1
1	Secondary contact	120, 277	25	15 minutes	A
2	Primary contact	600	60	5 seconds	A
3	Short-term fault induction	600	7	5 seconds	A
4	Long-term fault induction	100-600	2.2 (at 600 V)	15 minutes	A
5	High impedance induction			15 minutes	

**Table 5:** Test connection (table 4-1 of GR-1089-CORE).

Test	Two-wire interface	Four-wire interface
A	<ol style="list-style-type: none"> <li>1. Tip to generator, Ring to ground</li> <li>2. Ring to generator, Tip to ground</li> <li>3. Tip to generator, Ring to generator simultaneously</li> </ol>	<ol style="list-style-type: none"> <li>1. Each lead (T, R, T1, R1) to generator with other three leads grounded</li> <li>2. Tip and Ring to generator simultaneously, T1 and R1 to ground</li> <li>3. T1 and R1 to generator simultaneously, Tip and Ring to ground</li> </ol>
B	Tip to generator, Ring to generator simultaneously	T, R, T1, R1 to generator simultaneously



**Table 6:** Application of lightning and AC power fault test voltages (table 4-2 of GR-1089-CORE).

Test	S1	S2	S3	S4
T to generator, R to ground (condition A1 of table 4-1)	Closed	Open	Open	Closed
R to generator, T to ground (condition A2 of table 4-1)	Open	Closed	Closed	Open
T to generator, R to generator simultaneously (condition A3 of table 4-1)	Closed	Open	Closed	Open

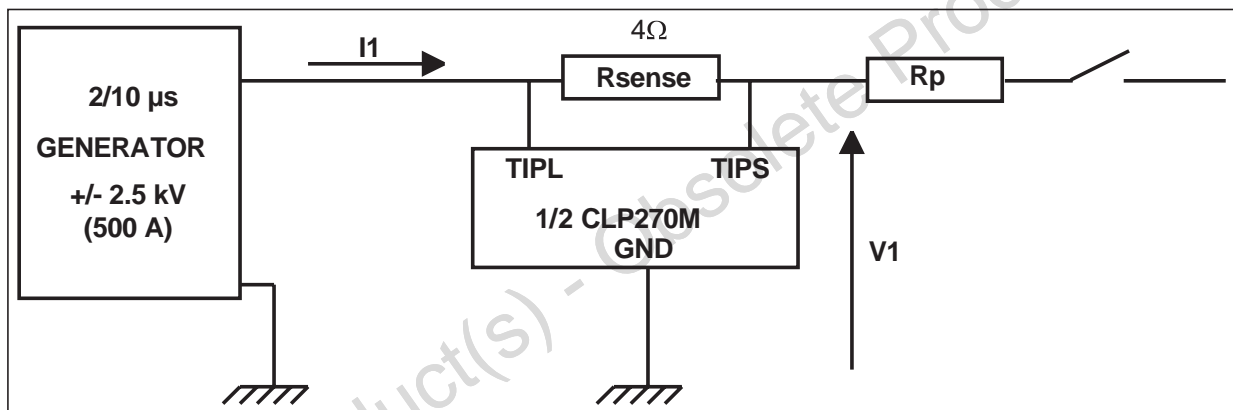
**2. First level lightning surge:**

**2.1. Ringing mode**

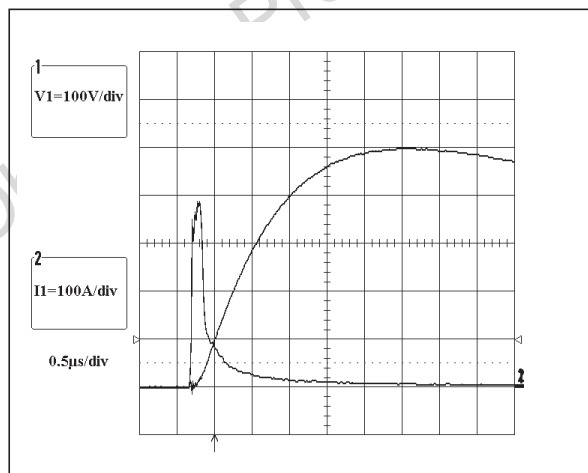
Lightning phenomena are the most common surge causes. The purpose of this test is to check the behavior of the CLP270M against these lightning strikes.

Figures 11 and 12 show that the remaining overvoltage does not exceed +/- 500 V. The CLP270M switches on within 250ns and withstands the 500A given by the BELLCORE 2/10µs generator.

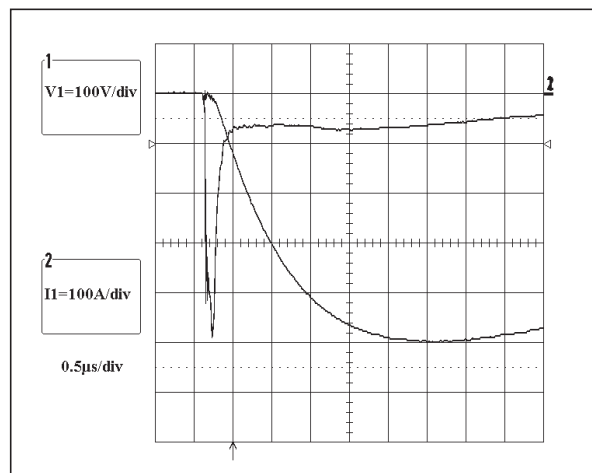
**Fig. 10:** Lightning simulation test.



**Fig. 11:** CLP270M response to a positive surge.

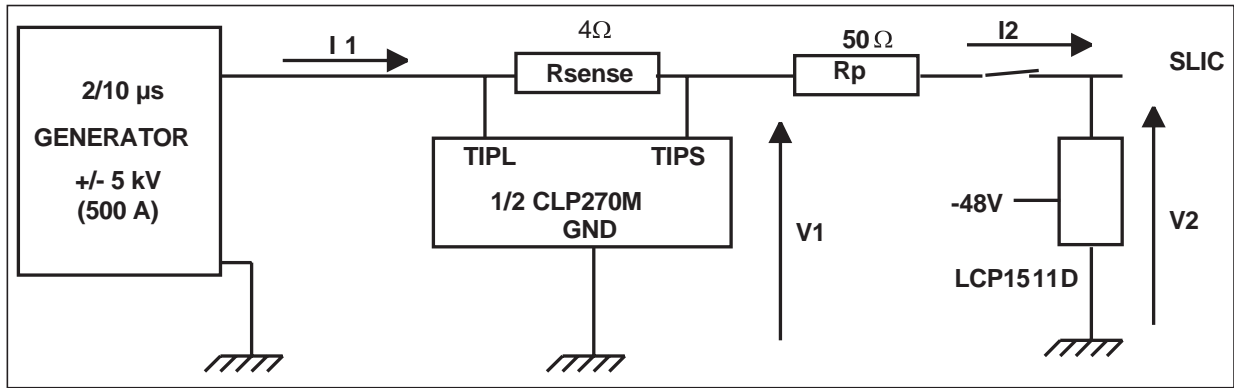


**Fig. 12 :** CLP270M response to a negative surge.



## APPLICATION NOTE

Fig. 13: Lightning test in speech mode.



### 2.2. Speech mode

Figures 14 and 15 give the voltage and current behavior during positive and negative 2.5kV, 2/10μs, 500A surge tests using a LCP1511D as second stage protection device. The firing threshold values are now adjusted to GND and to -Vbat (-48V) by the action of the second stage protection which acts as an external voltage reference.

As shown on these figures, the maximum remaining voltage does not exceed +8.5V for positive surges and -65V for negative surges.

Fig. 14: CLP270M response to a positive surge.

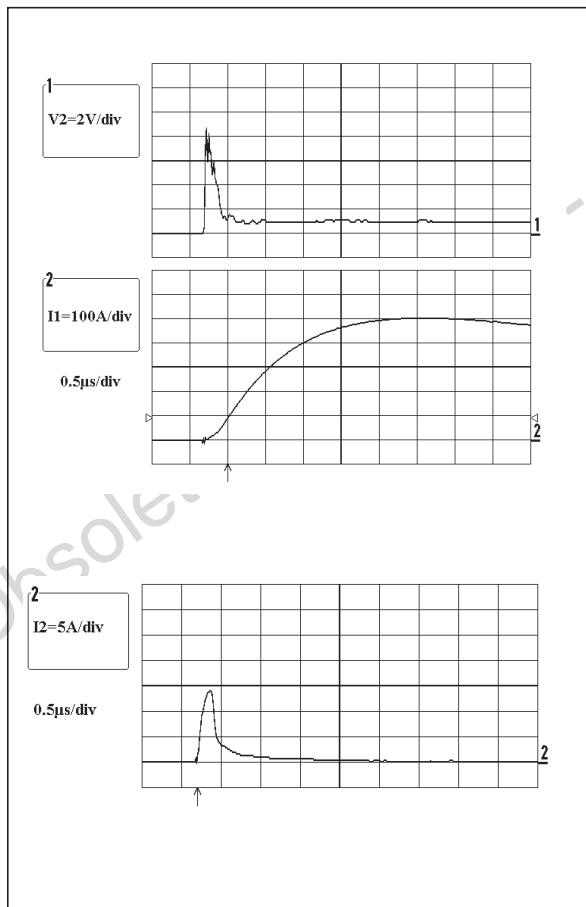
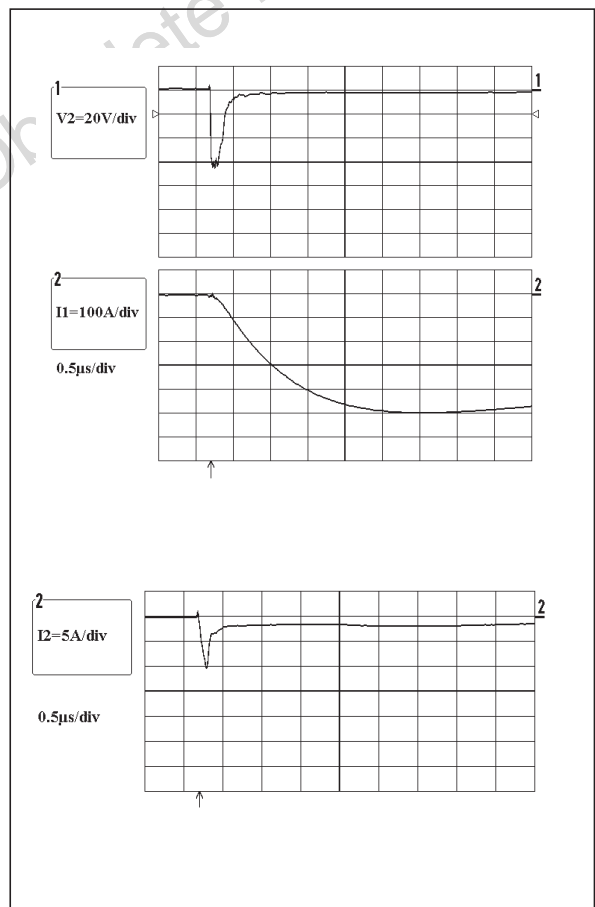


Fig. 15: CLP270M response to a negative surge.



### 3. Second level lightning surge

#### 3.1. Lightning test in ringing mode

The figures 17 and 18 give the voltage and current behavior during positive and negative 5kV, 2/10 $\mu$ s,500A surge with the CLP270M acting in Ringing mode.

Fig. 16: Lightning test in Ringing mode.

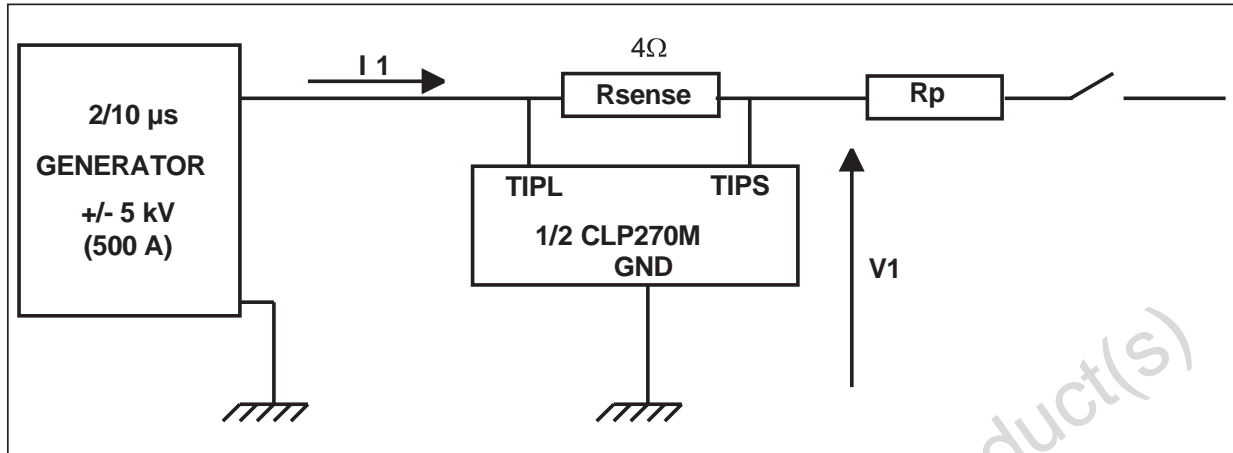


Fig. 17: CLP270M response to a positive surge.

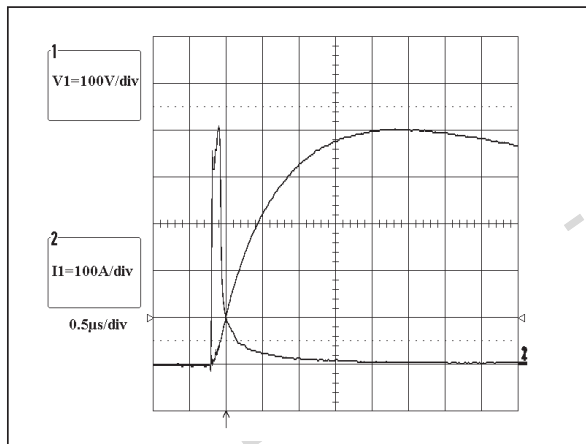
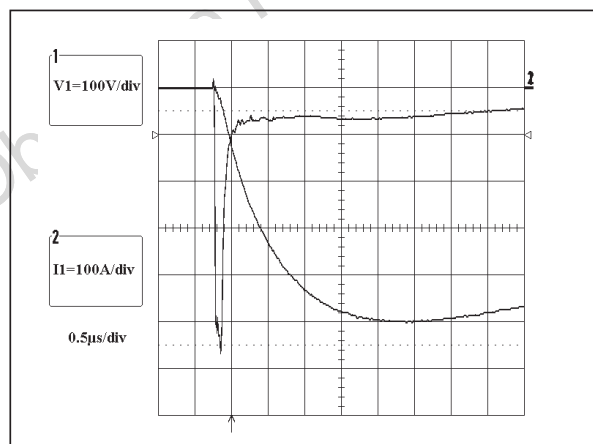


Fig. 18: CLP270M response to a negative surge.



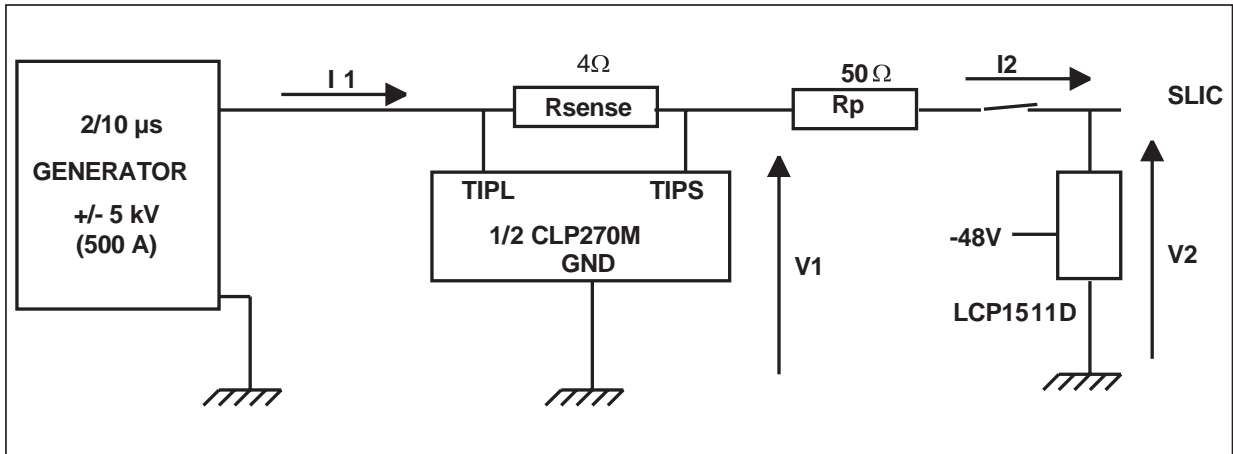
#### 3.2. Speech mode

The figures 20 and 22 give the voltage and current behavior during positive and negative 5kV, 2/10 $\mu$ s,500A surge with the CLP270M acting in speech mode.

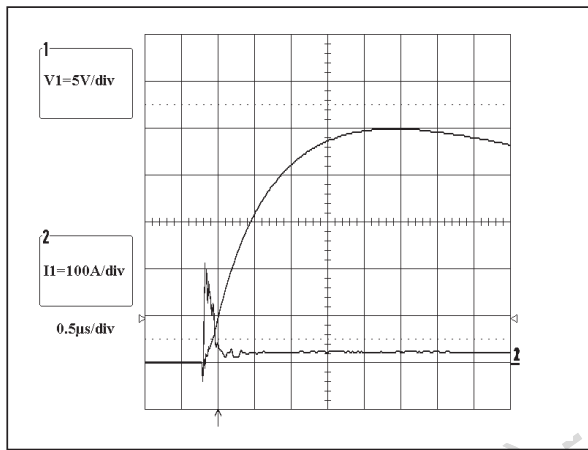
The CLP270M withstands the second level lightning surge test without trouble in both ringing and speech mode.

**APPLICATION NOTE**

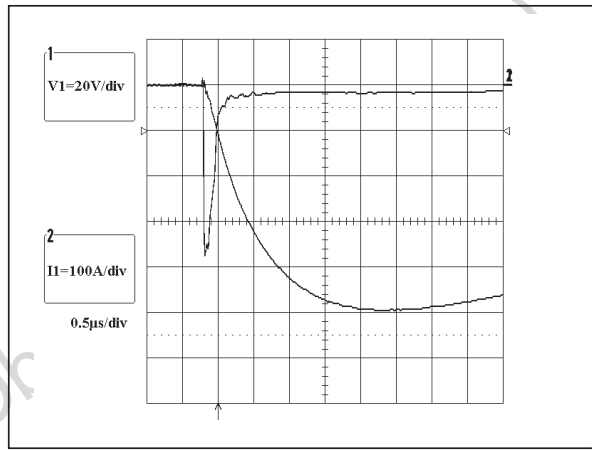
**Fig. 19:** Lightning test in Speech mode.



**Fig. 20:** CLP270M response to a positive surge.



**Fig. 21:** CLP270M response to a negative surge.

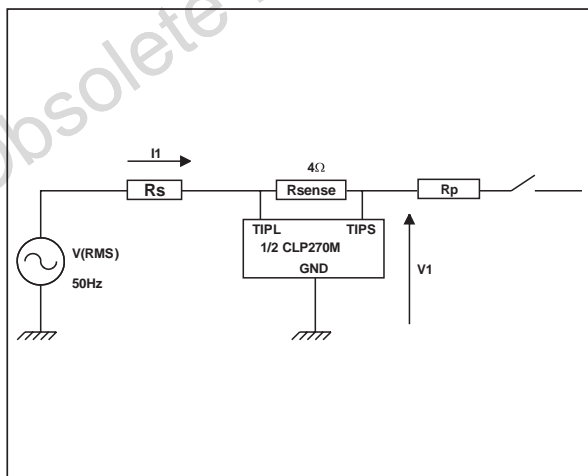


**4. First and second level AC Power fault.**

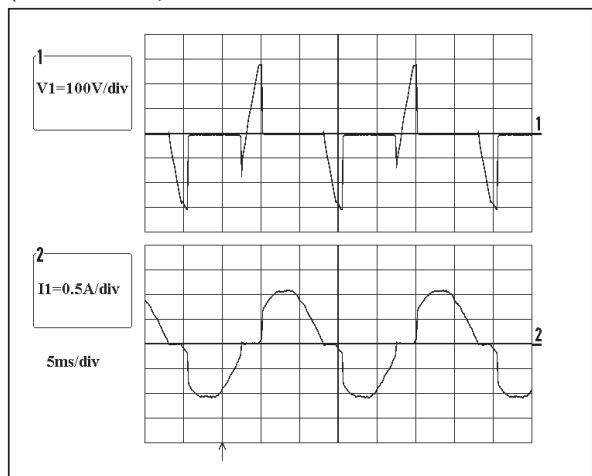
**4.1. Ringing mode**

The figures 23 and 25 give the voltage and current at the CLP270M terminals in Ringing mode and Speech mode.

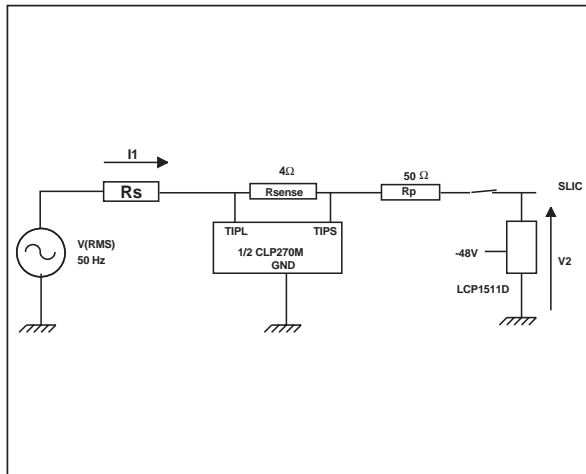
**Fig. 22:** AC power fault test in Ringing mode.



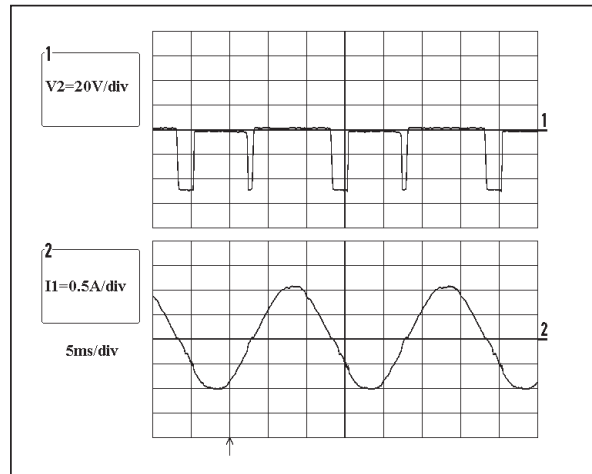
**Fig. 23:** Example of behavior when facing test 3 (400V, 600Ω).



**Fig. 24:** AC power fault test in Speech mode.



**Fig. 25:** Example of behavior when facing test 3 (400V, 600Ω).



### CONCLUSION

The CLP270M is able to withstand all the first level AC power fault tests as required in the table 4-7 of GR-1089-CORE standard, and then is suitable to protect the linecard.

As usual, for the second level AC power fault tests serial protection as PTC or fuse are needed.

All these curves, lightning and AC power fault represent the behavior of the CLP270M in worst case tests, anyhow the CLP270M withstands all the others surges of the Bellcore GR1098 standard. For the second level AC power fault test, the use of series protection elements (PTC or fuses) are needed.

The FS pin allows the system to monitor and record the number of surges occurring on the telecom line.

Information furnished is believed to be accurate and reliable. However, STMicroelectronics assumes no responsibility for the consequences of use of such information nor for any infringement of patents or other rights of third parties which may result from its use. No license is granted by implication or otherwise under any patent or patent rights of STMicroelectronics. Specifications mentioned in this publication are subject to change without notice. This publication supersedes and replaces all information previously supplied. STMicroelectronics products are not authorized for use as critical components in life support devices or systems without express written approval of STMicroelectronics.

The ST logo is a registered trademark of STMicroelectronics

© 2000 STMicroelectronics - Printed in Italy - All rights reserved.

STMicroelectronics GROUP OF COMPANIES

Australia - Brazil - China - Finland - France - Germany - Hong Kong - India - Italy - Japan - Malaysia  
Malta - Morocco - Singapore - Spain - Sweden - Switzerland - United Kingdom - U.S.A.

<http://www.st.com>