



SRIX4K

13.56MHz Short Range Contactless Memory Chip With 4096 bit EEPROM, Anti-Collision and Anti-Clone Functions

DATA BRIEFING

FEATURES SUMMARY

- ISO 14443 - 2 Type B Air Interface Compliant
- ISO 14443 - 3 Type B Frame Format Compliant
- 13.56MHz Carrier Frequency
- 847kHz Sub-carrier Frequency
- 106 Kbit/s Data Transfer
- France Telecom Proprietary Anti-Clone Function
- 8 bits Chip_ID based anticollision system
- 2 Count-Down Binary Counters
 - 32 bits each
 - 2^{32} units to be counted-down
- 64-bit Unique Identifier
- 4096-bit EEPROM with Write Protect Feature
- READ BLOCK & WRITE BLOCK (32 Bits)
- Internal Tuning Capacitor
- 1million ERASE/WRITE Cycles
- 10-Year Data Retention
- Self-Timed Programming Cycle
- 5ms Typical Programming Time

Figure 1. Delivery Forms

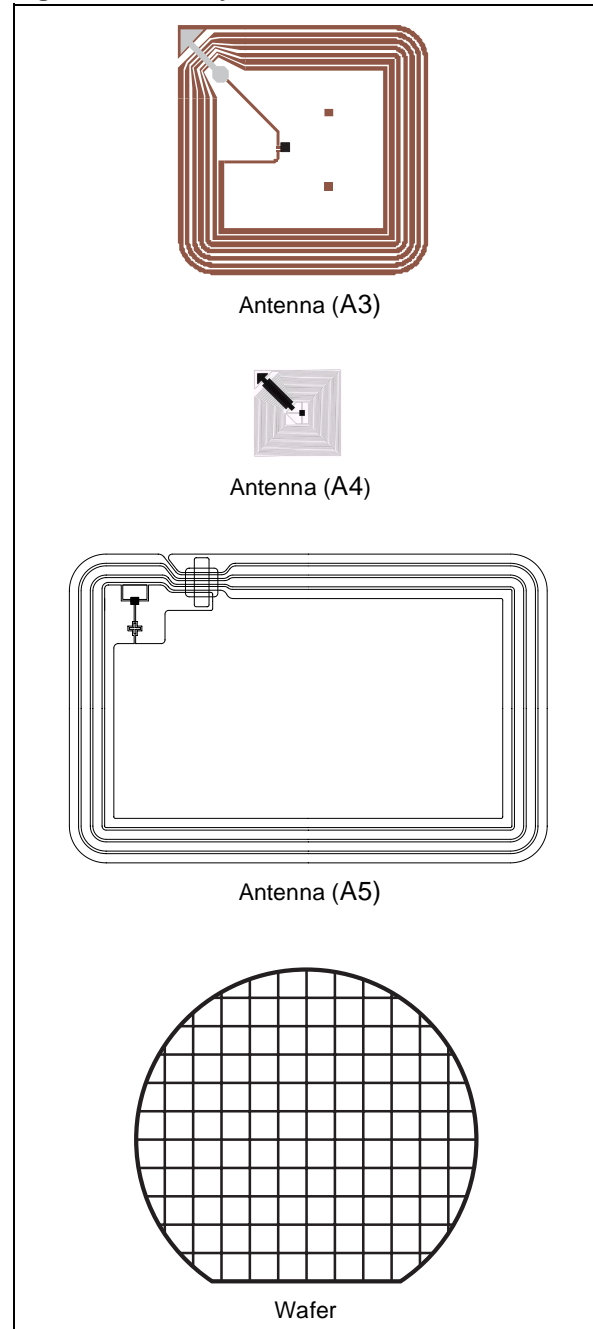

SUMMARY DESCRIPTION

The SRIX4K is a contactless memory, powered by an externally transmitted radio wave. It contains a 4096-bit user EEPROM fabricated with STMicroelectronics CMOS technology. The memory is organised as 128 blocks of 32 bits. The SRIX4K is accessed via the 13.56MHz carrier. Incoming data are demodulated and decoded from the received Amplitude Shift Keying (ASK) modulation signal and outgoing data are generated by load variation using Bit Phase Shift Keying (BPSK) coding of a 847kHz sub-carrier. The received ASK wave is 10% modulated. The Data transfer rate between the SRIX4K and the reader is 106Kbit/s in both reception and emission modes.

The SRIX4K follows the ISO 14443 part 2 type B recommendation for the radio-frequency power and signal interface.

Figure 2. Logic Diagram

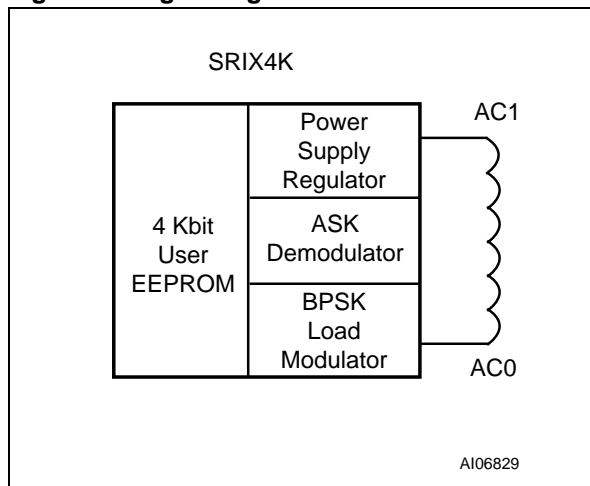

The SRIX4K targets short range applications which need secure and re-usable products. The SRIX4K includes an anti-collision mechanism that allows it to detect and select tags present at the same time within range of the reader. The anti-collision is based on a probabilistic scanning method using slot markers. The SRIX4K provides an anti-

clone function which allows its authentication. Using the STMicroelectronics single chip coupler, CRX14, it is easy to design a reader with the authentication capability and to build a system with a high level of security.

Table 1. Signal Names

AC1	Antenna Coil
AC0	Antenna Coil

The SRIX4K contactless EEPROM can be randomly read and write in block mode. Each block is composed by 32 bits. It offers a set of 10 commands:

- READ_BLOCK
- WRITE_BLOCK
- INITIATE
- PCALL16
- SLOT_MARKER
- SELECT
- COMPLETION
- RESET_TO_INVENTORY
- AUTHENTICATE
- GET_UID

The SRIX4K memory is organized in three areas, as described in Figure 3. The first area is a resettable OTP (one time programmable) area in which bits can only be switched from 1 to 0. Using a special command, it is possible to erase all bits of this area to 1. The second area provides two 32-bit binary counters which can only be decremented from FFFFFFFFh to 00000000h, and gives a capacity of 4,294,967,296 units per counter. The last area is the EEPROM memory. It is accessible by block of 32 bits and includes an auto-erase cycle during each WRITE_BLOCK command.

MEMORY MAPPING

The SRIX4K is organised as 128 blocks of 32 bits as shown in Figure 3. All blocks are accessible by the READ_BLOCK command. Depending on the

write access, they can be updated by the WRITE_BLOCK command. A WRITE_BLOCK updates all the 32 bits of the block.

Figure 3. SRIX4K Memory Mapping

Block Addr	Msb b ₃₁	b ₂₄ b ₂₃	32 bits Block b ₁₆ b ₁₅	b ₈ b ₇	Lsb b ₀	Description
0			32 bits Boolean Area			Resettable OTP bits
1			32 bits Boolean Area			
2			32 bits Boolean Area			
3			32 bits Boolean Area			
4			32 bits Boolean Area			
5			32 bits binary counter			Count down Counter
6			32 bits binary counter			
7			User Area			Lockable EEPROM
8			User Area			
9			User Area			
10			User Area			
11			User Area			
12			User Area			
13			User Area			
14			User Area			
15			User Area			
16			User Area			
...			User Area			
127			User Area			
255	OTP_Lock_Reg		ST Reserved		Fixed Chip_ID (Option)	System OTP bits
UID0	64 bits UID Area					ROM
UID1						

SRIX4K

PART NUMBERING

For a list of available options (speed, package, etc.) or for further information on any aspect of this

device, please contact your nearest ST Sales Office.

Table 2. Ordering Information Scheme

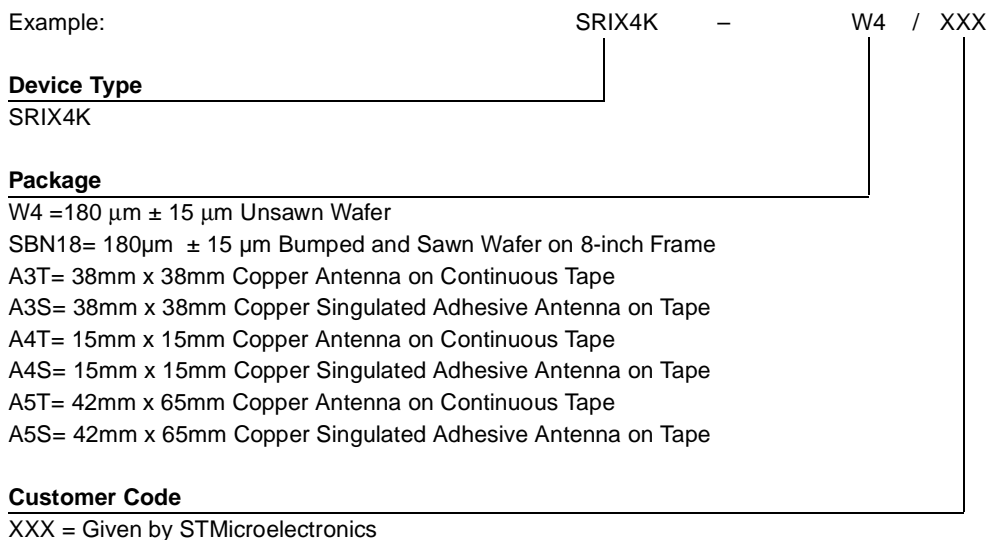

Information furnished is believed to be accurate and reliable. However, STMicroelectronics assumes no responsibility for the consequences of use of such information nor for any infringement of patents or other rights of third parties which may result from its use. No license is granted by implication or otherwise under any patent or patent rights of STMicroelectronics. Specifications mentioned in this publication are subject to change without notice. This publication supersedes and replaces all information previously supplied. STMicroelectronics products are not authorized for use as critical components in life support devices or systems without express written approval of STMicroelectronics.

The ST logo is registered trademark of STMicroelectronics
All other names are the property of their respective owners

© 2003 STMicroelectronics - All Rights Reserved

STMicroelectronics group of companies
Australia - Brazil - Canada - China - Finland - France - Germany - Hong Kong -
India - Israel - Italy - Japan - Malaysia - Malta - Morocco - Singapore - Spain - Sweden - Switzerland - United Kingdom - United States.
www.st.com