

LMK61XX High-Performance Ultra-Low Jitter Oscillator

1 Features

- Ultra-low Noise, High Performance
 - Jitter: 90 fs RMS Typical Fout > 100 MHz
 - PSRR: –70 dBc, Robust Supply Noise Immunity
- Supported Output Format
 - LVPECL up to 1 GHz
 - LVDS up to 900 MHz
 - HCSL up to 400 MHz
- Total Frequency Tolerance of ± 50 ppm (LMK61X2) and ± 25 ppm (LMK61X0)
- 3.3-V Operating Voltage
- Industrial Temperature Range (–40°C to +85°C)
- 7 mm × 5 mm 6-Pin Package, Pin-Compatible With Industry Standard 7050 XO Package

2 Applications

- High-Performance Replacement for Crystal, SAW, or Silicon-Based Oscillators
- Switches, Routers, Network Line Cards, Base Band Units (BBU), Servers, Storage/SAN
- Test and Measurement
- Medical Imaging
- FPGA, Processor Attach

3 Description

The LMK61XX is an ultra-low jitter oscillator that generates a commonly used reference clock. The device is pre-programmed in factory to support any reference clock frequency; supported output formats are LVPECL up to 1 GHz, LVDS up to 900 MHz, and HCSL up to 400 MHz. Internal power conditioning provide excellent power supply ripple rejection (PSRR), reducing the cost and complexity of the power delivery network. The device operates from a single 3.3 V ± 5% supply.

Device Information⁽¹⁾

PART NUMBER	OUTPUT FREQ (MHz) AND FORMAT	TOTAL FREQ STABILITY (PPM)	PACKAGE
LMK61A2-100M00	100 LVDS	± 50	6-pin QFM (7.0 mm x 5.0 mm)
LMK61A2-125M00	125 LVDS	± 50	
LMK61A2-156M25	156.25 LVDS	± 50	
LMK61A2-312M50	312.5 LVDS	± 50	
LMK61A2-644M53	644.53125 LVDS	± 50	
LMK61E0-050M00	50 LVPECL	± 25	
LMK61E0-155M52	155.52 LVPECL	± 25	
LMK61E0-156M25	156.25 LVPECL	± 25	
LMK61E2-100M00	100 LVPECL	± 50	
LMK61E2-125M00	125 LVPECL	± 50	
LMK61E2-156M25	156.25 LVPECL	± 50	
LMK61E2-312M50	312.5 LVPECL	± 50	
LMK61I2-100M00	100 HCSL	± 50	

(1) For all available packages, see the orderable addendum at the end of the data sheet.

Pinout

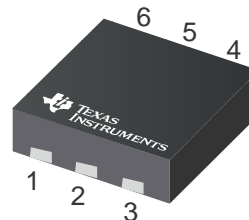
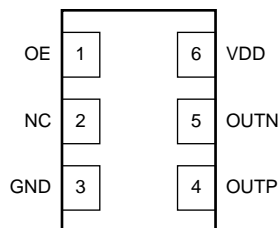

Table of Contents

1 Features	1	6.13 PLL Clock Output Jitter Characteristics	7
2 Applications	1	6.14 Typical 156.25-MHz Output Phase Noise Characteristics	7
3 Description	1	6.15 Additional Reliability and Qualification	7
4 Revision History	2	6.16 Typical Characteristics	8
5 Pin Configuration and Functions	3	7 Parameter Measurement Information	10
6 Specifications	4	7.1 Device Output Configurations	10
6.1 Absolute Maximum Ratings	4	8 Power Supply Recommendations	12
6.2 ESD Ratings	4	9 Layout	12
6.3 Recommended Operating Conditions	4	9.1 Layout Guidelines	12
6.4 Thermal Information	4	10 Device and Documentation Support	14
6.5 Electrical Characteristics - Power Supply	5	10.1 Related Links	14
6.6 LVPECL Output Characteristics	5	10.2 Receiving Notification of Documentation Updates	14
6.7 LVDS Output Characteristics	5	10.3 Community Resources	14
6.8 HCSL Output Characteristics	6	10.4 Trademarks	14
6.9 OE Input Characteristics	6	10.5 Electrostatic Discharge Caution	14
6.10 Frequency Tolerance Characteristics	6	10.6 Glossary	14
6.11 Power-On/Reset Characteristics (VDD)	6	11 Mechanical, Packaging, and Orderable Information	15
6.12 PSRR Characteristics	7		

4 Revision History

NOTE: Page numbers for previous revisions may differ from page numbers in the current version.

Changes from Revision C (September 2017) to Revision D	Page
• Added LMK61A2-644M	1
• Added LMK61E0-156M	1

Changes from Revision B (March 2017) to Revision C	Page
• Added LMK61E0-155M	1

Changes from Revision A (November 2015) to Revision B	Page
• Updated data sheet text to the latest documentation and translations standards	1
• Added LMK61E0-050M	1
• Updated key graphic	1
• Added <i>Receiving Notification of Documentation Updates</i> section	14

Changes from Original (October 2015) to Revision A	Page
• Product Preview to Production Data Datasheet	1

5 Pin Configuration and Functions

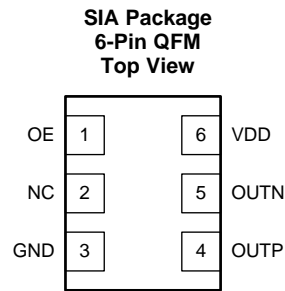

Pin Functions

PIN		I/O	DESCRIPTION
NAME	NO.		
POWER			
GND	3	Ground	Device Ground.
VDD	6	Analog	3.3 V Power Supply.
OUTPUT BLOCK			
OUTP, OUTN	4, 5	Universal	Differential Output Pair (LVPECL, LVDS or HCSL).
DIGITAL CONTROL / INTERFACES			
NC	2	N/A	No Connect.
OE	1	LVC MOS	Output Enable (internal pullup). When set to low, output pair is disabled and set at high impedance.

6 Specifications

6.1 Absolute Maximum Ratings

over operating free-air temperature range (unless otherwise noted)⁽¹⁾

		MIN	MAX	UNIT
V _{DD}	Device supply voltage	-0.3	3.6	V
V _{IN}	Output voltage for logic inputs	-0.3	V _{DD} + 0.3	V
V _{OUT}	Output voltage for clock outputs	-0.3	V _{DD} + 0.3	V
T _J	Junction temperature		150	°C
T _{STG}	Storage temperature	-40	125	°C

(1) Stresses beyond those listed under *Absolute Maximum Ratings* may cause permanent damage to the device. These are stress ratings only, which do not imply functional operation of the device at these or any other conditions beyond those indicated under *Recommended Operating Conditions*. Exposure to absolute maximum-rated conditions for extended periods may affect device reliability.

6.2 ESD Ratings

		VALUE	UNIT
V _(ESD)	Electrostatic discharge	Human-body model (HBM), per ANSI/ESDA/JEDEC JS-001 ⁽¹⁾	±4000
		Charged-device model (CDM), per JEDEC specification JESD22-C101 ⁽²⁾	±1500

(1) JEDEC document JEP155 states that 500 V HBM allows safe manufacturing with a standard ESD control process.

(2) JEDEC document JEP157 states that 250 V CDM allows safe manufacturing with a standard ESD control process.

6.3 Recommended Operating Conditions

over operating free-air temperature range (unless otherwise noted)

		MIN	NOM	MAX	UNIT
V _{DD}	Device supply voltage	3.135	3.3	3.465	V
T _A	Ambient temperature	-40	25	85	°C
T _J	Junction temperature	LMK61X2		125	°C
		LMK61X0		115	°C
t _{RAMP}	V _{DD} power-up ramp time	0.1		100	ms

6.4 Thermal Information

THERMAL METRIC ⁽¹⁾	LMK61XX ^{(2) (3) (4)}			UNIT	
	SIA (QFM)				
	6 PINS				
	Airflow (LFM) 0	Airflow (LFM) 200	Airflow (LFM) 400		
R _{θJA}	Junction-to-ambient thermal resistance	55.2	46.4	43.7	°C/W
R _{θJC(top)}	Junction-to-case (top) thermal resistance	34.6	n/a	n/a	°C/W
R _{θJB}	Junction-to-board thermal resistance	37.7	n/a	n/a	°C/W
ψ _{JT}	Junction-to-top characterization parameter	11.3	17.6	22.5	°C/W
ψ _{JB}	Junction-to-board characterization parameter	37.7	41.5	40.1	°C/W
R _{θJC(bot)}	Junction-to-case (bottom) thermal resistance	n/a	n/a	n/a	°C/W

(1) For more information about traditional and new thermal metrics, see the [Semiconductor and IC Package Thermal Metrics](#) application report.

(2) The package thermal resistance is calculated on a 4 layer JEDEC board.

(3) Connected to GND with 3 thermal vias (0.3-mm diameter).

(4) ψ_{JB} (junction to board) is used when the main heat flow is from the junction to the GND pad. Please refer to Thermal Considerations section for more information on ensuring good system reliability and quality.

6.5 Electrical Characteristics - Power Supply⁽¹⁾

VDD = 3.3 V ± 5%, T_A = -40°C to 85°C

PARAMETER		TEST CONDITIONS	MIN	TYP	MAX	UNIT
IDD	Device current consumption	LVPECL ⁽²⁾		162	208	mA
		LVDS		152	196	
		HCSL		155	196	
IDD-PD	Device current consumption when output is disabled	OE = GND		136		mA

(1) Refer to Parameter Measurement Information for relevant test conditions.

(2) On-chip power dissipation should exclude 40 mW, dissipated in the 150 ohm termination resistors, from total power dissipation.

6.6 LVPECL Output Characteristics⁽¹⁾

VDD = 3.3 V ± 5%, T_A = -40°C to 85°C

PARAMETER		TEST CONDITIONS	MIN	TYP	MAX	UNIT
f _{OUT}	Output frequency ⁽²⁾		10		1000	MHz
V _{OD}	Output voltage swing (V _{OH} – V _{OL}) ⁽²⁾		700	800	1200	mV
V _{OUT, DIFF, PP}	Differential output peak-to-peak swing			2 × V _{OD}		V
V _{OS}	Output common-mode voltage			VDD – 1.55		V
t _R / t _F	Output rise/fall time (20% to 80%) ⁽³⁾			120	200	ps
PN-Floor	Output phase noise floor (f _{OFFSET} > 10 MHz)	156.25 MHz		–165		dBc/Hz
ODC	Output duty cycle ⁽³⁾		45%		55%	

(1) Refer to Parameter Measurement Information for relevant test conditions.

(2) An output frequency over f_{OUT} max spec is possible, but output swing may be less than V_{OD} min spec.

(3) Ensured by characterization.

6.7 LVDS Output Characteristics⁽¹⁾

VDD = 3.3 V ± 5%, T_A = -40°C to 85°C

PARAMETER		TEST CONDITIONS	MIN	TYP	MAX	UNIT
f _{OUT}	Output frequency ⁽¹⁾		10		900	MHz
V _{OD}	Output voltage swing (V _{OH} – V _{OL}) ⁽¹⁾		300	390	480	mV
V _{OUT, DIFF, PP}	Differential output peak-to-peak swing			2 × V _{OD}		V
V _{OS}	Output common-mode voltage			1.2		V
t _R / t _F	Output rise/fall time (20% to 80%) ⁽²⁾			150	250	ps
PN-Floor	Output phase noise floor (f _{OFFSET} > 10 MHz)	156.25 MHz		–162		dBc/Hz
ODC	Output duty cycle ⁽²⁾		45%		55%	
R _{OUT}	Differential output impedance			125		Ohm

(1) An output frequency over f_{OUT} max spec is possible, but output swing may be less than V_{OD} min spec.

(2) Ensured by characterization.

6.8 HCSL Output Characteristics⁽¹⁾

VDD = 3.3 V ± 5%, T_A = –40°C to 85°C

PARAMETER	TEST CONDITIONS	MIN	TYP	MAX	UNIT
f _{OUT}	Output frequency	10		400	MHz
V _{OH}	Output high voltage	600		850	mV
V _{OL}	Output low voltage	–100		100	mV
V _{CROSS}	Absolute crossing voltage ⁽²⁾⁽³⁾	250		475	mV
V _{CROSS-DELTA}	Variation of V _{CROSS} ⁽²⁾⁽³⁾	0		140	mV
dV/dt	Slew rate ⁽⁴⁾	0.8		2	V/ns
PN-Floor	Output phase noise floor (f _{OFFSET} > 10 MHz)	100 MHz		–164	dBc/Hz
ODC	Output duty cycle ⁽⁴⁾	45%		55%	

(1) Refer to Parameter Measurement Information for relevant test conditions.

(2) Measured from –150 mV to +150 mV on the differential waveform with the 300 mVpp measurement window centered on the differential zero crossing.

(3) Ensured by design.

(4) Ensured by characterization.

6.9 OE Input Characteristics

VDD = 3.3 V ± 5%, T_A = –40°C to 85°C

PARAMETER	TEST CONDITIONS	MIN	TYP	MAX	UNIT
V _{IH}	Input high voltage	1.4			V
V _{IL}	Input low voltage			0.6	V
I _{IH}	Input high current	V _{IH} = VDD		40	µA
I _{IL}	Input low current	V _{IL} = GND		40	µA
C _{IN}	Input capacitance		2		pF

6.10 Frequency Tolerance Characteristics⁽¹⁾

VDD = 3.3 V ± 5%, T_A = –40°C to 85°C

PARAMETER	TEST CONDITIONS	MIN	TYP	MAX	UNIT	
f _T	Total frequency tolerance	LMK61X2: All output formats, frequency bands and device junction temperature up to 125°C; includes initial freq tolerance, temperature & supply voltage variation, solder reflow and aging (10 years)	–50		50	ppm
		LMK61X0: All output formats, frequency bands and device junction temperature up to 115°C; includes initial freq tolerance, temperature & supply voltage variation, solder reflow and aging (5 years at 40°C)	–25		25	ppm

(1) Ensured by characterization.

6.11 Power-On/Reset Characteristics (VDD)

VDD = 3.3 V ± 5%, T_A = –40°C to 85°C

PARAMETER	TEST CONDITIONS	MIN	TYP	MAX	UNIT
V _{THRESH}	Threshold voltage ⁽¹⁾	2.72		2.95	V
V _{DROOP}	Allowable voltage droop ⁽²⁾			0.1	V
t _{STARTUP}	Start-up time ⁽¹⁾	Time elapsed from VDD at 3.135 V to output enabled		10	ms
t _{OE-EN}	Output enable time ⁽²⁾	Time elapsed from OE at V _{IH} to output enabled		50	µs
t _{OE-DIS}	Output disable time ⁽²⁾	Time elapsed from OE at V _{IL} to output disabled		50	µs

(1) Ensured by characterization.

(2) Ensured by design.

6.12 PSRR Characteristics⁽¹⁾

VDD = 3.3 V, T_A = 25°C, FS[1:0] = NC, NC

PARAMETER		TEST CONDITIONS	MIN	TYP	MAX	UNIT
PSRR	Spurs induced by 50-mV power supply ripple ⁽²⁾⁽³⁾ at 156.25-MHz output, all output types	Sine wave at 50 kHz		-70		dBc
		Sine wave at 100 kHz		-70		
		Sine wave at 500 kHz		-70		
		Sine wave at 1 MHz		-70		

(1) Refer to Parameter Measurement Information for relevant test conditions.

(2) Measured max spur level with 50 mVpp sinusoidal signal between 50 kHz and 1 MHz applied on VDD pin

(3) $DJ_{SPUR} (ps, pk-pk) = [2 \cdot 10 \cdot (SPUR/20) / (\pi \cdot f_{OUT})] \cdot 1e6$, where PSRR or SPUR in dBc and f_{OUT} in MHz.

6.13 PLL Clock Output Jitter Characteristics⁽¹⁾⁽²⁾

VDD = 3.3 V ± 5%, T_A = -40°C to 85°C

PARAMETER		TEST CONDITIONS	MIN	TYP	MAX	UNIT
RJ	RMS phase jitter ⁽³⁾ (12 kHz – 20 MHz) (1 kHz – 5 MHz)	f _{OUT} < 100 MHz, all output types		200	300	fs RMS
RJ	RMS phase jitter ⁽³⁾ (12 kHz – 20 MHz) (1 kHz – 5 MHz)	f _{OUT} ≥ 100 MHz (except 155.52 MHz and 644.53125 MHz), all output types		100	200	fs RMS
RJ	RMS phase jitter ⁽³⁾ (12 kHz – 20 MHz) (1 kHz – 5 MHz)	f _{OUT} = 155.52 MHz or 644.53125 MHz, all output types		150	300	fs RMS

(1) Refer to Parameter Measurement Information for relevant test conditions.

(2) Phase jitter measured with Agilent E5052 signal source analyzer using a differential-to-single ended converter (balun or buffer).

(3) Ensured by characterization.

6.14 Typical 156.25-MHz Output Phase Noise Characteristics⁽¹⁾⁽²⁾

VDD = 3.3 V, T_A = 25°C, Output Type = LVPECL/LVDS/HCSL

PARAMETER		OUTPUT TYPE			UNITS
		LVPECL	LVDS	HCSL	
phn _{10k}	Phase noise at 10-kHz offset	-143	-143	-143	dBc/Hz
Phn _{20k}	Phase noise at 20-kHz offset	-143	-143	-143	dBc/Hz
phn _{100k}	Phase noise at 100-kHz offset	-144	-144	-144	dBc/Hz
Phn _{200k}	Phase noise at 200-kHz offset	-145	-145	-145	dBc/Hz
phn _{1M}	Phase noise at 1-MHz offset	-150	-150	-150	dBc/Hz
phn _{2M}	Phase noise at 2-MHz offset	-154	-154	-154	dBc/Hz
phn _{10M}	Phase noise at 10-MHz offset	-165	-162	-164	dBc/Hz
phn _{20M}	Phase noise at 20-MHz offset	-165	-162	-164	dBc/Hz

(1) Refer to Parameter Measurement Information for relevant test conditions.

(2) Phase jitter measured with Agilent E5052 signal source analyzer using a differential-to-single ended converter (balun or buffer).

6.15 Additional Reliability and Qualification

PARAMETER	CONDITION / TEST METHOD
Mechanical Shock	MIL-STD-202, Method 213
Mechanical Vibration	MIL-STD-202, Method 204
Moisture Sensitivity Level	J-STD-020, MSL3

6.16 Typical Characteristics

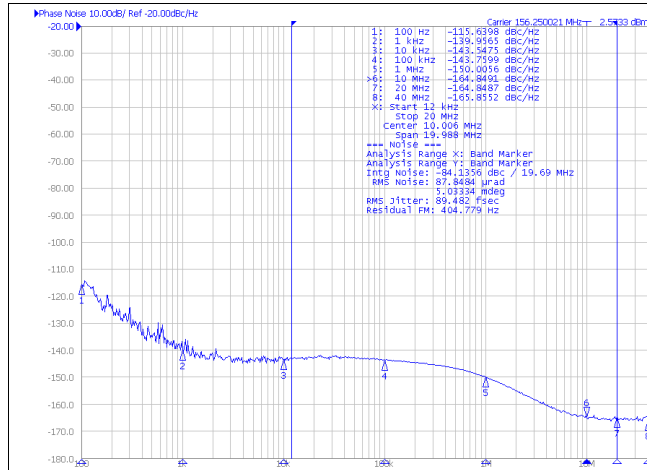

Figure 1. Phase Noise of 156.25-MHz LVPECL Differential Output

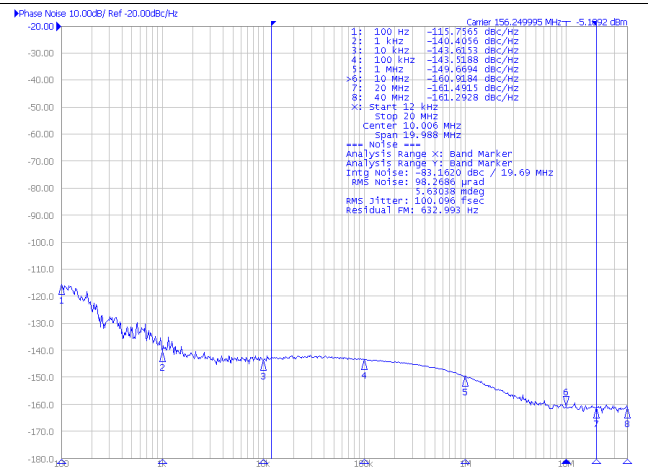

Figure 2. Phase Noise of 156.25-MHz LVDS Differential Output

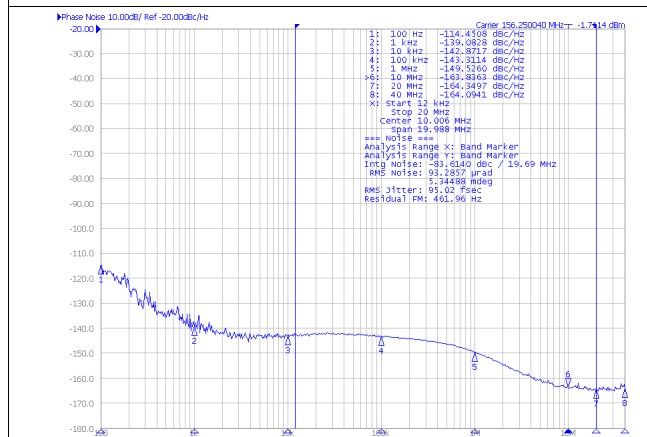

Figure 3. Phase Noise of 156.25-MHz HCSL Differential Output

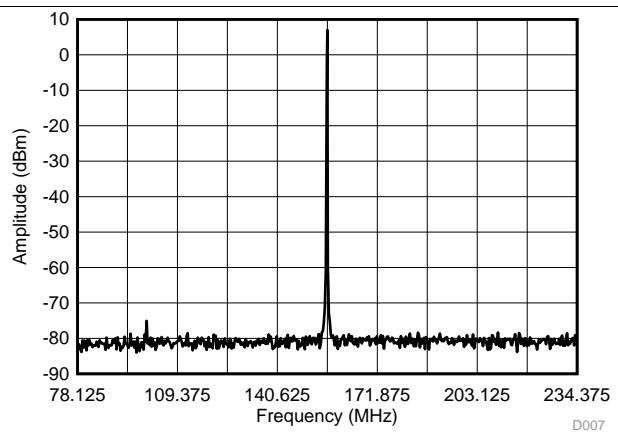

Figure 4. 156.25 ± 78.125-MHz LVPECL Differential Output Spectrum

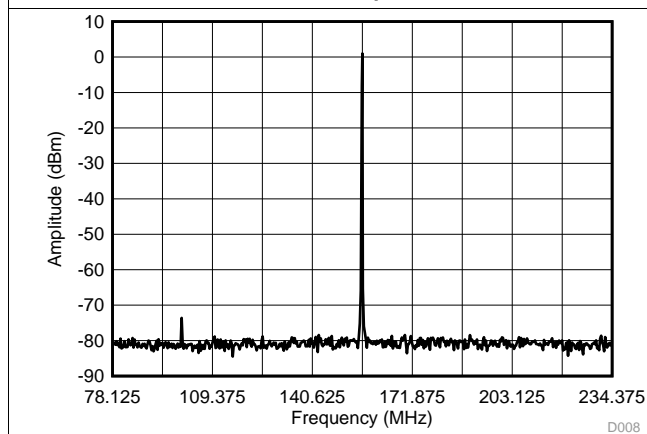

Figure 5. 156.25 ± 78.125-MHz LVDS Differential Output Spectrum

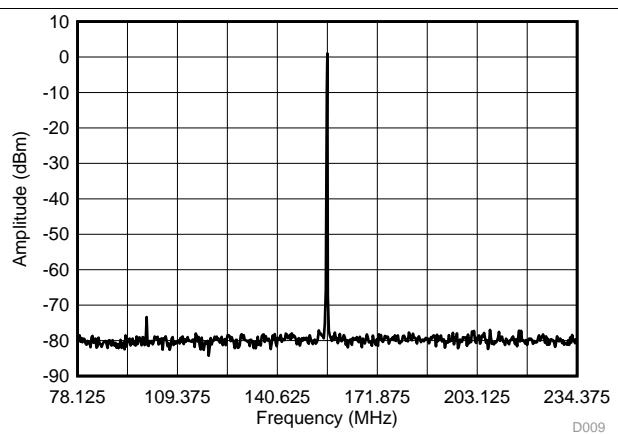

Figure 6. 156.25 ± 78.125-MHz HCSL Differential Output Spectrum

Typical Characteristics (continued)

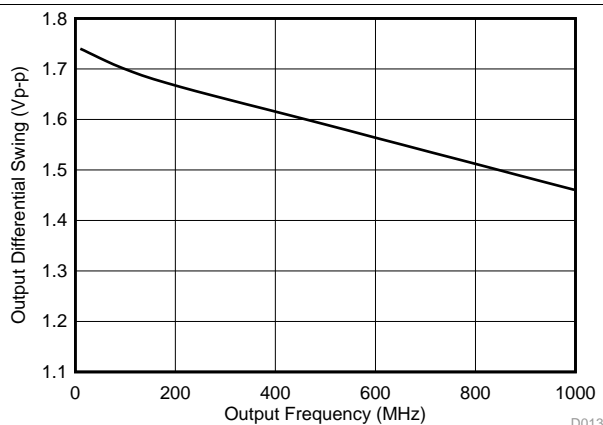

Figure 7. LVPECL Differential Output Swing vs Frequency

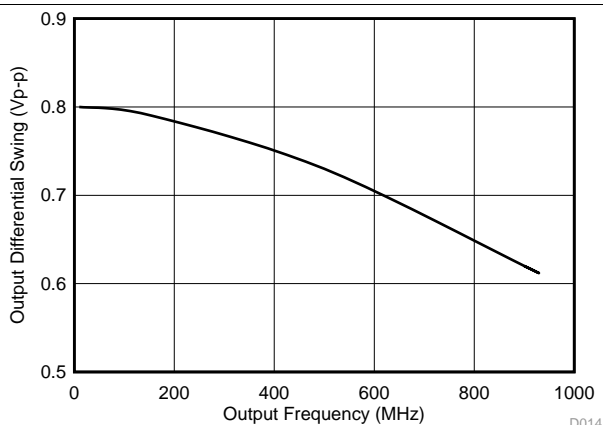

Figure 8. LVDS Differential Output Swing vs Frequency

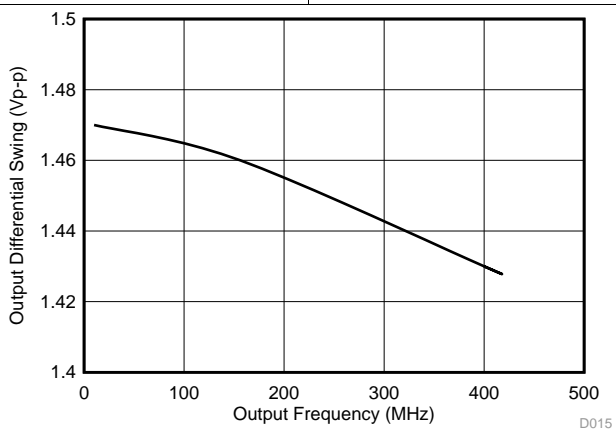

Figure 9. HCSL Differential Output Swing vs Frequency

7 Parameter Measurement Information

7.1 Device Output Configurations

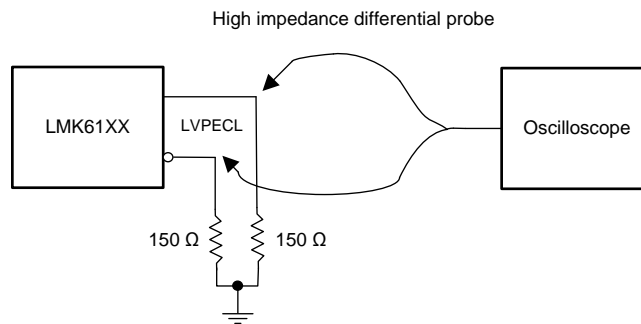

Figure 10. LVPECL Output DC Configuration During Device Test

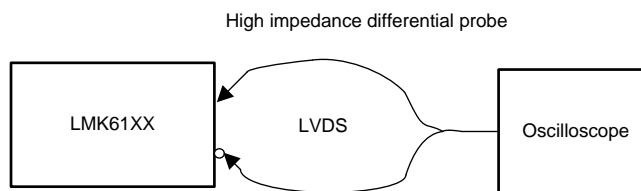

Figure 11. LVDS Output DC Configuration During Device Test

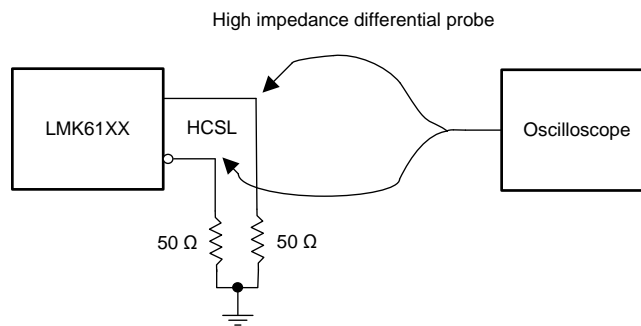

Figure 12. HCSL Output DC Configuration During Device Test

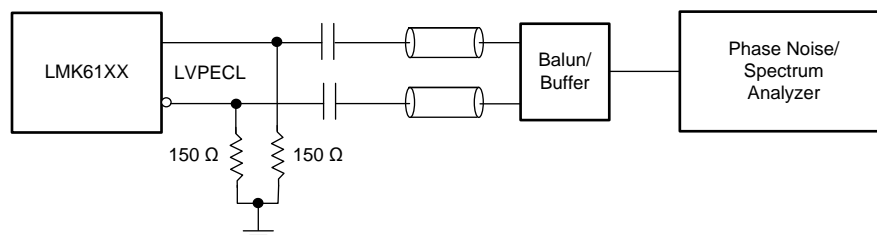

Figure 13. LVPECL Output AC Configuration During Device Test

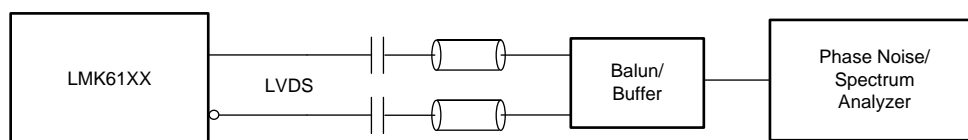

Figure 14. LVDS Output AC Configuration During Device Test

Device Output Configurations (continued)

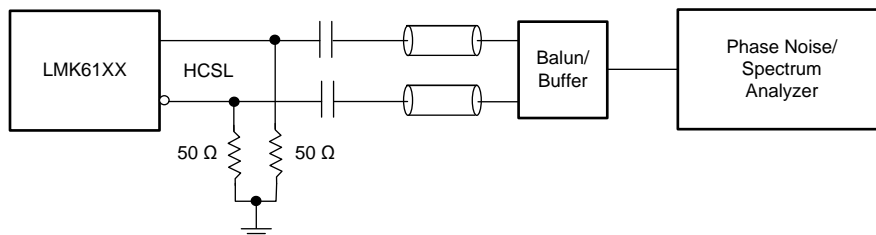

Figure 15. HCSL Output AC Configuration During Device Test

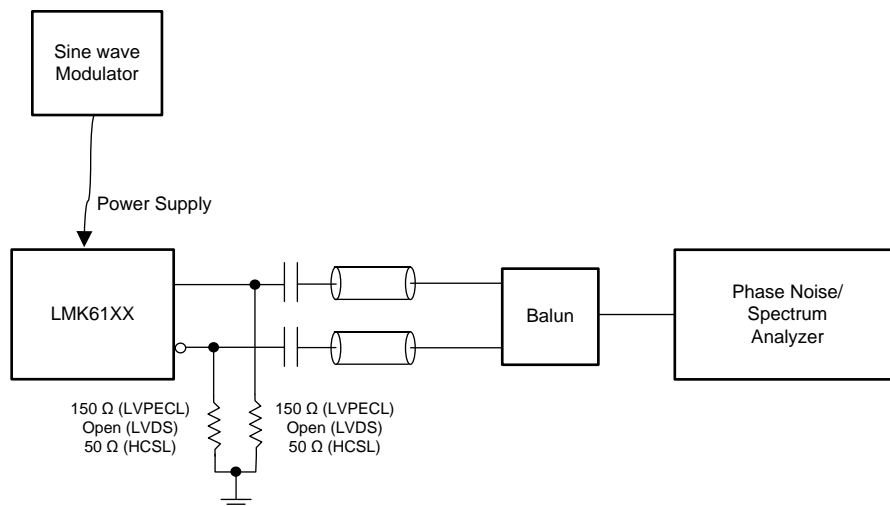

Figure 16. PSRR Test Setup

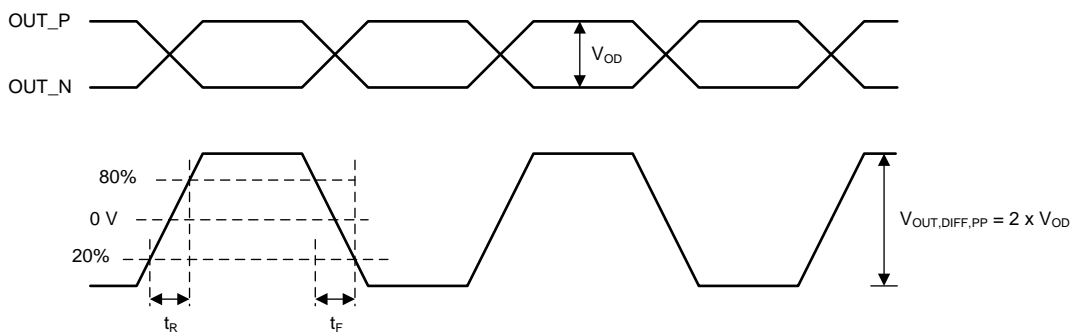

Figure 17. Differential Output Voltage and Rise/Fall Time

8 Power Supply Recommendations

For best electrical performance of LMK61XX, TI recommends using a combination of 10 μF , 1 μF and 0.1 μF on its power supply bypass network. TI also recommends using component side mounting of the power supply bypass capacitors and it is best to use 0201 or 0402 body size capacitors to facilitate signal routing. Keep the connections between the bypass capacitors and the power supply on the device as short as possible. Ground the other side of the capacitor using a low impedance connection to the ground plane. [Figure 18](#) shows the layout recommendation for power supply decoupling of LMK61XX.

9 Layout

9.1 Layout Guidelines

The following sections provides recommendations for board layout, solder reflow profile and power supply bypassing when using LMK61XX to ensure good thermal / electrical performance and overall signal integrity of entire system.

9.1.1 Ensuring Thermal Reliability

The LMK61XX is a high performance device. Therefore, pay careful attention to device configuration and printed-circuit board (PCB) layout with respect to power consumption. The ground pin needs to be connected to the ground plane of the PCB through three vias or more, as shown in [Figure 18](#), to maximize thermal dissipation out of the package.

[Equation 1](#) describes the relationship between the PCB temperature around the LMK61XX and its junction temperature.

$$T_B = T_J - \Psi_{JB} \times P$$

where

- T_B : PCB temperature around the LMK61XX
 - T_J : Junction temperature of LMK61XX
 - Ψ_{JB} : Junction-to-board thermal resistance parameter of LMK61XX (37.7°C/W without airflow)
 - P : On-chip power dissipation of LMK61XX
- (1)

To ensure that the maximum junction temperature of LMK61X2 is below 125°C, the maximum PCB temperature without airflow should be at 99°C or below (89°C or below for LMK61X0) when the device is optimized for best performance resulting in maximum on-chip power dissipation of 0.68 W.

9.1.2 Best Practices for Signal Integrity

For best electrical performance and signal integrity of entire system with LMK61XX, TI recommends routing vias into decoupling capacitors and then into the LMK61XX. TI also recommends increasing the via count and width of the traces wherever possible. These steps ensure lowest impedance and shortest path for high frequency current flow. [Figure 18](#) shows the layout recommendation for LMK61XX.

Layout Guidelines (continued)

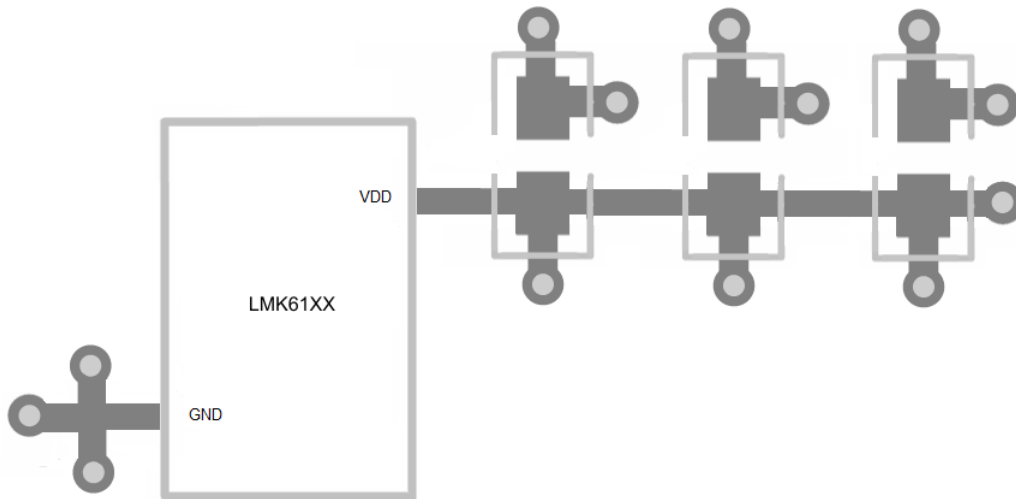

Figure 18. LMK61XX Layout Recommendation for Power Supply and Ground

9.1.3 Recommended Solder Reflow Profile

TI recommends following the solder paste supplier's recommendations to optimize flux activity and to achieve proper melting temperatures of the alloy within the guidelines of J-STD-20. It is preferable for the LMK61XX to be processed with the lowest peak temperature possible while also remaining below the components peak temperature rating as listed on the MSL label. The exact temperature profile would depend on several factors including maximum peak temperature for the component as rated on the MSL label, Board thickness, PCB material type, PCB geometries, component locations, sizes, densities within PCB, as well solder manufactures recommended profile, and capability of the reflow equipment to as confirmed by the SMT assembly operation.

10 Device and Documentation Support

10.1 Related Links

The table below lists quick access links. Categories include technical documents, support and community resources, tools and software, and quick access to sample or buy.

Table 1. Related Links

PARTS	PRODUCT FOLDER	SAMPLE & BUY	TECHNICAL DOCUMENTS	TOOLS & SOFTWARE	SUPPORT & COMMUNITY
LMK61E0-050M	Click here	Click here	Click here	Click here	Click here
LMK61E0-155M	Click here	Click here	Click here	Click here	Click here
LMK61E0-156M	Click here	Click here	Click here	Click here	Click here
LMK61E2-100M	Click here	Click here	Click here	Click here	Click here
LMK61E2-125M	Click here	Click here	Click here	Click here	Click here
LMK61E2-156M	Click here	Click here	Click here	Click here	Click here
LMK61E2-312M	Click here	Click here	Click here	Click here	Click here
LMK61A2-100M	Click here	Click here	Click here	Click here	Click here
LMK61A2-125M	Click here	Click here	Click here	Click here	Click here
LMK61A2-156M	Click here	Click here	Click here	Click here	Click here
LMK61A2-312M	Click here	Click here	Click here	Click here	Click here
LMK61A2-644M	Click here	Click here	Click here	Click here	Click here
LMK61I2-100M	Click here	Click here	Click here	Click here	Click here

10.2 Receiving Notification of Documentation Updates

To receive notification of documentation updates, navigate to the device product folder on ti.com. In the upper right corner, click on *Alert me* to register and receive a weekly digest of any product information that has changed. For change details, review the revision history included in any revised document.

10.3 Community Resources

The following links connect to TI community resources. Linked contents are provided "AS IS" by the respective contributors. They do not constitute TI specifications and do not necessarily reflect TI's views; see TI's [Terms of Use](#).

TI E2E™ Online Community *TI's Engineer-to-Engineer (E2E) Community*. Created to foster collaboration among engineers. At e2e.ti.com, you can ask questions, share knowledge, explore ideas and help solve problems with fellow engineers.

Design Support *TI's Design Support* Quickly find helpful E2E forums along with design support tools and contact information for technical support.

10.4 Trademarks

E2E is a trademark of Texas Instruments.
 All other trademarks are the property of their respective owners.

10.5 Electrostatic Discharge Caution



These devices have limited built-in ESD protection. The leads should be shorted together or the device placed in conductive foam during storage or handling to prevent electrostatic damage to the MOS gates.

10.6 Glossary

[SLYZ022](#) — *TI Glossary*.

This glossary lists and explains terms, acronyms, and definitions.

11 Mechanical, Packaging, and Orderable Information

The following pages include mechanical, packaging, and orderable information. This information is the most current data available for the designated devices. This data is subject to change without notice and revision of this document. For browser-based versions of this data sheet, refer to the left-hand navigation.

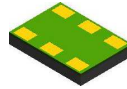

PACKAGE OUTLINE

SIA0006A

QFM - 1.15 mm max height

QUAD FLAT MODULE

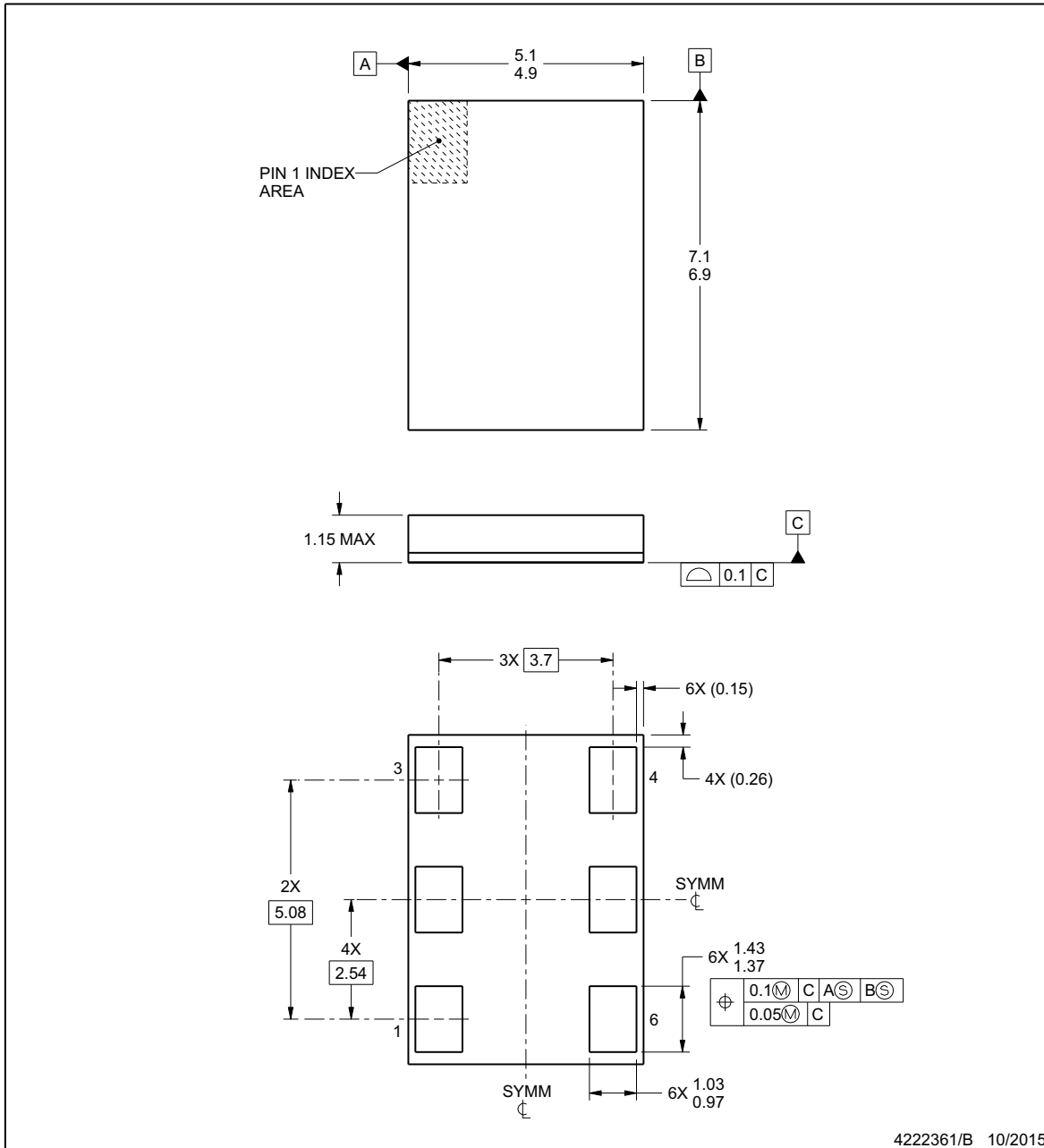

NOTES:

1. All linear dimensions are in millimeters. Any dimensions in parenthesis are for reference only. Dimensioning and tolerancing per ASME Y14.5M.
2. This drawing is subject to change without notice.

EXAMPLE BOARD LAYOUT

SIA0006A

QFM - 1.15 mm max height

QUAD FLAT MODULE

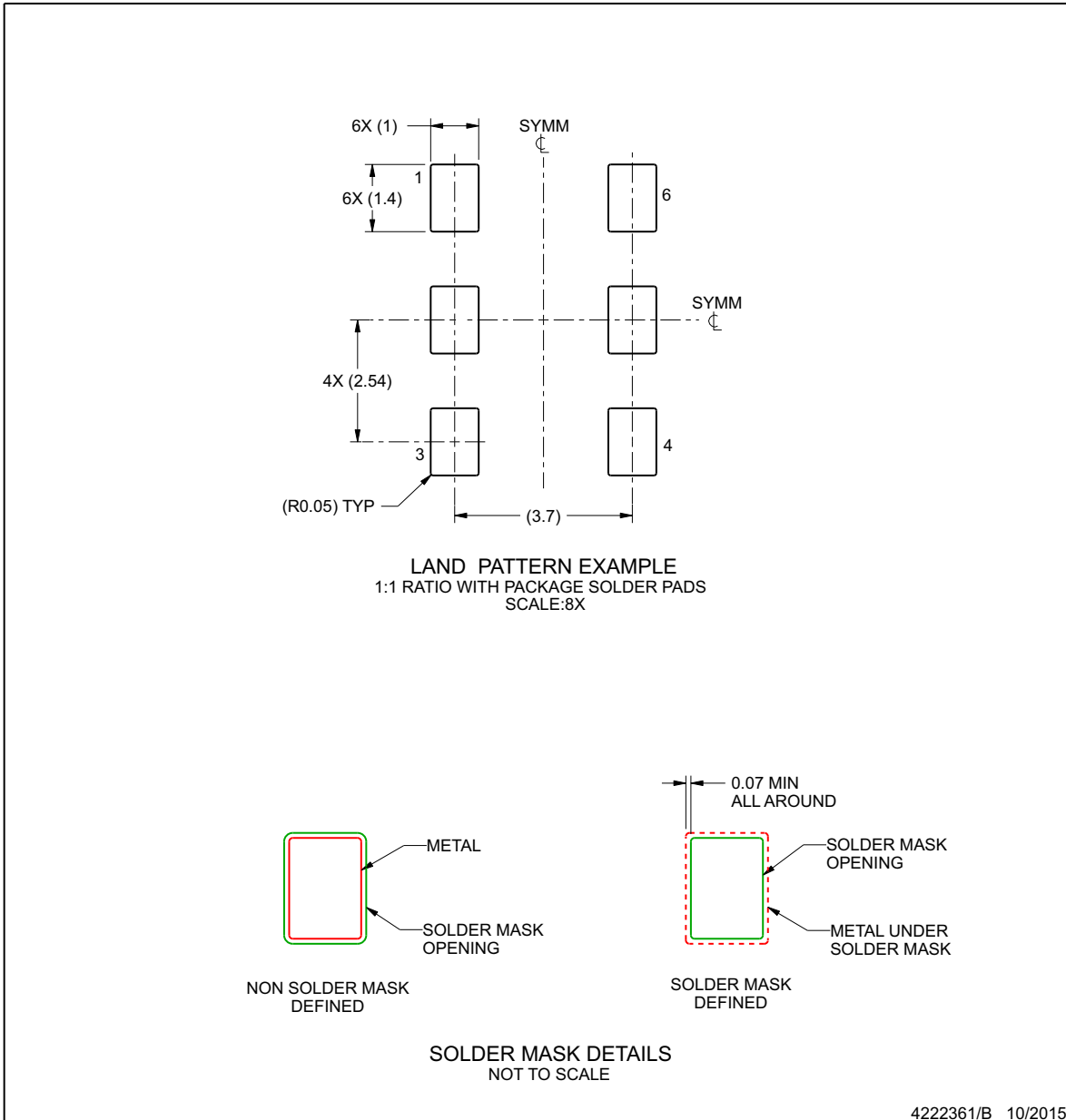

NOTES: (continued)

3. For more information, see Texas Instruments literature number SLUA271 (www.ti.com/lit/slua271).

EXAMPLE STENCIL DESIGN

SIA0006A

QFM - 1.15 mm max height

QUAD FLAT MODULE

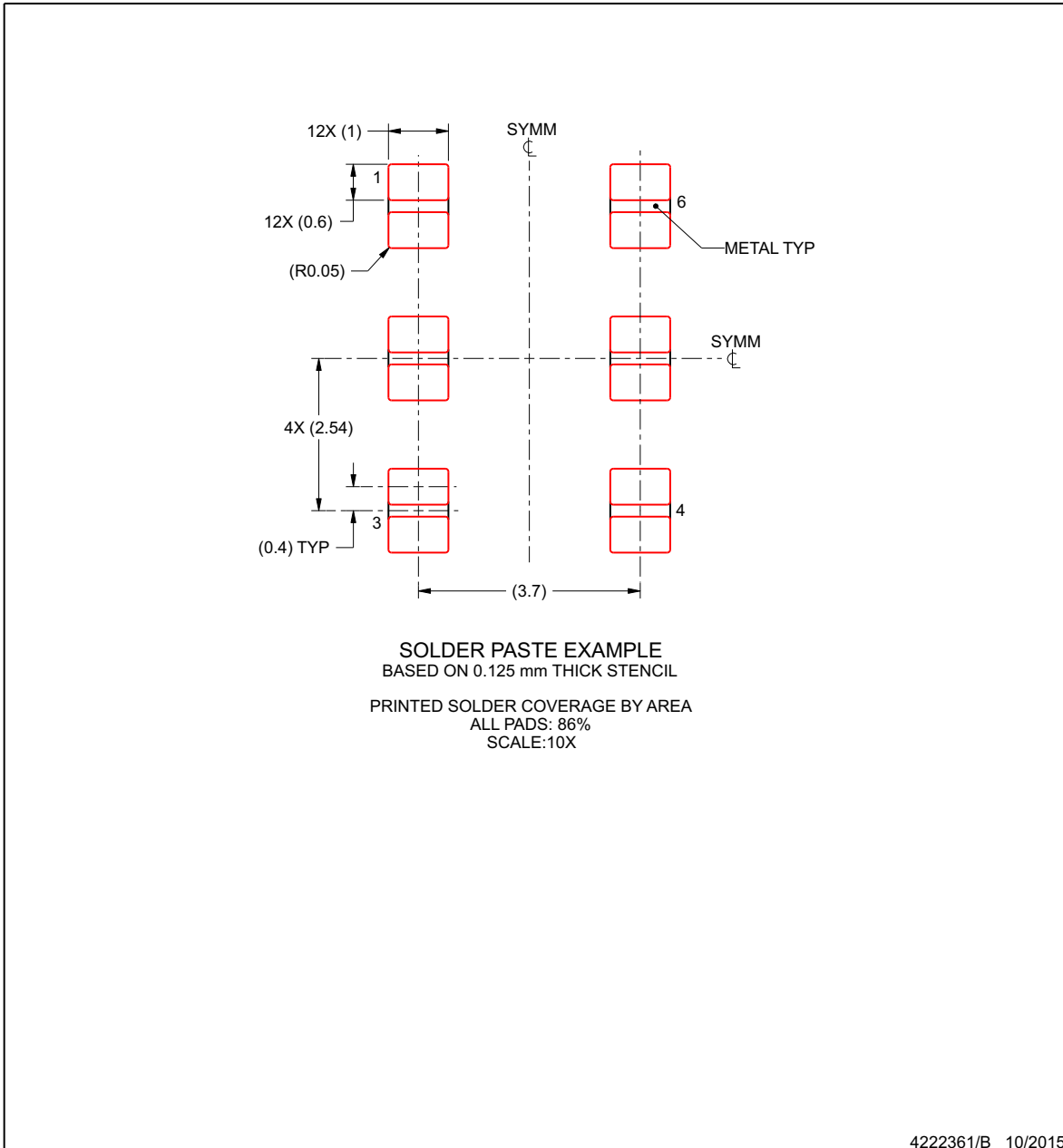

NOTES: (continued)

4. Laser cutting apertures with trapezoidal walls and rounded corners may offer better paste release. IPC-7525 may have alternate design recommendations.

PACKAGING INFORMATION

Orderable Device	Status (1)	Package Type	Package Drawing	Pins	Package Qty	Eco Plan (2)	Lead/Ball Finish (6)	MSL Peak Temp (3)	Op Temp (°C)	Device Marking (4/5)	Samples
LMK61A2-100M00SIAR	ACTIVE	QFM	SIA	6	2500	Green (RoHS & no Sb/Br)	Call TI NIAU	Level-3-260C-168 HR	-40 to 85	LMK61A2 100M00	Samples
LMK61A2-100M00SIAT	ACTIVE	QFM	SIA	6	250	Green (RoHS & no Sb/Br)	Call TI NIAU	Level-3-260C-168 HR	-40 to 85	LMK61A2 100M00	Samples
LMK61A2-125M00SIAR	ACTIVE	QFM	SIA	6	2500	Green (RoHS & no Sb/Br)	Call TI NIAU	Level-3-260C-168 HR	-40 to 85	LMK61A2 125M00	Samples
LMK61A2-125M00SIAT	ACTIVE	QFM	SIA	6	250	Green (RoHS & no Sb/Br)	Call TI NIAU	Level-3-260C-168 HR	-40 to 85	LMK61A2 125M00	Samples
LMK61A2-156M25SIAR	ACTIVE	QFM	SIA	6	2500	Green (RoHS & no Sb/Br)	Call TI NIAU	Level-3-260C-168 HR	-40 to 85	LMK61A2 156M25	Samples
LMK61A2-156M25SIAT	ACTIVE	QFM	SIA	6	250	Green (RoHS & no Sb/Br)	Call TI NIAU	Level-3-260C-168 HR	-40 to 85	LMK61A2 156M25	Samples
LMK61A2-312M50SIAR	ACTIVE	QFM	SIA	6	2500	Green (RoHS & no Sb/Br)	Call TI NIAU	Level-3-260C-168 HR	-40 to 85	LMK61A2 312M50	Samples
LMK61A2-312M50SIAT	ACTIVE	QFM	SIA	6	250	Green (RoHS & no Sb/Br)	Call TI NIAU	Level-3-260C-168 HR	-40 to 85	LMK61A2 312M50	Samples
LMK61A2-644M53SIAR	ACTIVE	QFM	SIA	6	2500	Green (RoHS & no Sb/Br)	NIAU	Level-3-260C-168 HR	-40 to 85	LMK61A2 644M53	Samples
LMK61A2-644M53SIAT	ACTIVE	QFM	SIA	6	250	Green (RoHS & no Sb/Br)	NIAU	Level-3-260C-168 HR	-40 to 85	LMK61A2 644M53	Samples
LMK61E0-050M00SIAR	ACTIVE	QFM	SIA	6	2500	Green (RoHS & no Sb/Br)	NIAU	Level-3-260C-168 HR	-40 to 85	LMK61E0 050M00	Samples
LMK61E0-050M00SIAT	ACTIVE	QFM	SIA	6	250	Green (RoHS & no Sb/Br)	NIAU	Level-3-260C-168 HR	-40 to 85	LMK61E0 050M00	Samples
LMK61E0-155M52SIAR	ACTIVE	QFM	SIA	6	2500	Green (RoHS & no Sb/Br)	NIAU	Level-3-260C-168 HR	-40 to 85	LMK61E0 155M52	Samples
LMK61E0-155M52SIAT	ACTIVE	QFM	SIA	6	250	Green (RoHS & no Sb/Br)	NIAU	Level-3-260C-168 HR	-40 to 85	LMK61E0 155M52	Samples
LMK61E0-156M25SIAR	ACTIVE	QFM	SIA	6	2500	Green (RoHS & no Sb/Br)	NIAU	Level-3-260C-168 HR	-40 to 85	LMK61E0 156M25	Samples
LMK61E0-156M25SIAT	ACTIVE	QFM	SIA	6	250	Green (RoHS & no Sb/Br)	NIAU	Level-3-260C-168 HR	-40 to 85	LMK61E0 156M25	Samples
LMK61E2-100M00SIAR	ACTIVE	QFM	SIA	6	2500	Green (RoHS & no Sb/Br)	Call TI NIAU	Level-3-260C-168 HR	-40 to 85	LMK61E2 100M00	Samples

Orderable Device	Status (1)	Package Type	Package Drawing	Pins	Package Qty	Eco Plan (2)	Lead/Ball Finish (6)	MSL Peak Temp (3)	Op Temp (°C)	Device Marking (4/5)	Samples
LMK61E2-100M00SIAT	ACTIVE	QFM	SIA	6	250	Green (RoHS & no Sb/Br)	Call TI NIAU	Level-3-260C-168 HR	-40 to 85	LMK61E2 100M00	Samples
LMK61E2-125M00SIAR	ACTIVE	QFM	SIA	6	2500	Green (RoHS & no Sb/Br)	Call TI NIAU	Level-3-260C-168 HR	-40 to 85	LMK61E2 125M00	Samples
LMK61E2-125M00SIAT	ACTIVE	QFM	SIA	6	250	Green (RoHS & no Sb/Br)	Call TI NIAU	Level-3-260C-168 HR	-40 to 85	LMK61E2 125M00	Samples
LMK61E2-156M25SIAR	ACTIVE	QFM	SIA	6	2500	Green (RoHS & no Sb/Br)	Call TI NIAU	Level-3-260C-168 HR	-40 to 85	LMK61E2 156M25	Samples
LMK61E2-156M25SIAT	ACTIVE	QFM	SIA	6	250	Green (RoHS & no Sb/Br)	Call TI NIAU	Level-3-260C-168 HR	-40 to 85	LMK61E2 156M25	Samples
LMK61E2-312M50SIAR	ACTIVE	QFM	SIA	6	2500	Green (RoHS & no Sb/Br)	Call TI NIAU	Level-3-260C-168 HR	-40 to 85	LMK61E2 312M50	Samples
LMK61E2-312M50SIAT	ACTIVE	QFM	SIA	6	250	Green (RoHS & no Sb/Br)	Call TI NIAU	Level-3-260C-168 HR	-40 to 85	LMK61E2 312M50	Samples
LMK61I2-100M00SIAR	ACTIVE	QFM	SIA	6	2500	Green (RoHS & no Sb/Br)	Call TI NIAU	Level-3-260C-168 HR	-40 to 85	LMK61I2 100M00	Samples
LMK61I2-100M00SIAT	ACTIVE	QFM	SIA	6	250	Green (RoHS & no Sb/Br)	Call TI NIAU	Level-3-260C-168 HR	-40 to 85	LMK61I2 100M00	Samples

(1) The marketing status values are defined as follows:

ACTIVE: Product device recommended for new designs.

LIFEBUY: TI has announced that the device will be discontinued, and a lifetime-buy period is in effect.

NRND: Not recommended for new designs. Device is in production to support existing customers, but TI does not recommend using this part in a new design.

PREVIEW: Device has been announced but is not in production. Samples may or may not be available.

OBSOLETE: TI has discontinued the production of the device.

(2) **RoHS:** TI defines "RoHS" to mean semiconductor products that are compliant with the current EU RoHS requirements for all 10 RoHS substances, including the requirement that RoHS substance do not exceed 0.1% by weight in homogeneous materials. Where designed to be soldered at high temperatures, "RoHS" products are suitable for use in specified lead-free processes. TI may reference these types of products as "Pb-Free".

RoHS Exempt: TI defines "RoHS Exempt" to mean products that contain lead but are compliant with EU RoHS pursuant to a specific EU RoHS exemption.

Green: TI defines "Green" to mean the content of Chlorine (Cl) and Bromine (Br) based flame retardants meet JS709B low halogen requirements of <=1000ppm threshold. Antimony trioxide based flame retardants must also meet the <=1000ppm threshold requirement.

(3) MSL, Peak Temp. - The Moisture Sensitivity Level rating according to the JEDEC industry standard classifications, and peak solder temperature.

(4) There may be additional marking, which relates to the logo, the lot trace code information, or the environmental category on the device.

⁽⁵⁾ Multiple Device Markings will be inside parentheses. Only one Device Marking contained in parentheses and separated by a "-" will appear on a device. If a line is indented then it is a continuation of the previous line and the two combined represent the entire Device Marking for that device.

⁽⁶⁾ Lead/Ball Finish - Orderable Devices may have multiple material finish options. Finish options are separated by a vertical ruled line. Lead/Ball Finish values may wrap to two lines if the finish value exceeds the maximum column width.

Important Information and Disclaimer:The information provided on this page represents TI's knowledge and belief as of the date that it is provided. TI bases its knowledge and belief on information provided by third parties, and makes no representation or warranty as to the accuracy of such information. Efforts are underway to better integrate information from third parties. TI has taken and continues to take reasonable steps to provide representative and accurate information but may not have conducted destructive testing or chemical analysis on incoming materials and chemicals. TI and TI suppliers consider certain information to be proprietary, and thus CAS numbers and other limited information may not be available for release.

In no event shall TI's liability arising out of such information exceed the total purchase price of the TI part(s) at issue in this document sold by TI to Customer on an annual basis.

IMPORTANT NOTICE

Texas Instruments Incorporated (TI) reserves the right to make corrections, enhancements, improvements and other changes to its semiconductor products and services per JESD46, latest issue, and to discontinue any product or service per JESD48, latest issue. Buyers should obtain the latest relevant information before placing orders and should verify that such information is current and complete.

TI's published terms of sale for semiconductor products (<http://www.ti.com/sc/docs/stdterms.htm>) apply to the sale of packaged integrated circuit products that TI has qualified and released to market. Additional terms may apply to the use or sale of other types of TI products and services.

Reproduction of significant portions of TI information in TI data sheets is permissible only if reproduction is without alteration and is accompanied by all associated warranties, conditions, limitations, and notices. TI is not responsible or liable for such reproduced documentation. Information of third parties may be subject to additional restrictions. Resale of TI products or services with statements different from or beyond the parameters stated by TI for that product or service voids all express and any implied warranties for the associated TI product or service and is an unfair and deceptive business practice. TI is not responsible or liable for any such statements.

Buyers and others who are developing systems that incorporate TI products (collectively, "Designers") understand and agree that Designers remain responsible for using their independent analysis, evaluation and judgment in designing their applications and that Designers have full and exclusive responsibility to assure the safety of Designers' applications and compliance of their applications (and of all TI products used in or for Designers' applications) with all applicable regulations, laws and other applicable requirements. Designer represents that, with respect to their applications, Designer has all the necessary expertise to create and implement safeguards that (1) anticipate dangerous consequences of failures, (2) monitor failures and their consequences, and (3) lessen the likelihood of failures that might cause harm and take appropriate actions. Designer agrees that prior to using or distributing any applications that include TI products, Designer will thoroughly test such applications and the functionality of such TI products as used in such applications.

TI's provision of technical, application or other design advice, quality characterization, reliability data or other services or information, including, but not limited to, reference designs and materials relating to evaluation modules, (collectively, "TI Resources") are intended to assist designers who are developing applications that incorporate TI products; by downloading, accessing or using TI Resources in any way, Designer (individually or, if Designer is acting on behalf of a company, Designer's company) agrees to use any particular TI Resource solely for this purpose and subject to the terms of this Notice.

TI's provision of TI Resources does not expand or otherwise alter TI's applicable published warranties or warranty disclaimers for TI products, and no additional obligations or liabilities arise from TI providing such TI Resources. TI reserves the right to make corrections, enhancements, improvements and other changes to its TI Resources. TI has not conducted any testing other than that specifically described in the published documentation for a particular TI Resource.

Designer is authorized to use, copy and modify any individual TI Resource only in connection with the development of applications that include the TI product(s) identified in such TI Resource. NO OTHER LICENSE, EXPRESS OR IMPLIED, BY ESTOPPEL OR OTHERWISE TO ANY OTHER TI INTELLECTUAL PROPERTY RIGHT, AND NO LICENSE TO ANY TECHNOLOGY OR INTELLECTUAL PROPERTY RIGHT OF TI OR ANY THIRD PARTY IS GRANTED HEREIN, including but not limited to any patent right, copyright, mask work right, or other intellectual property right relating to any combination, machine, or process in which TI products or services are used. Information regarding or referencing third-party products or services does not constitute a license to use such products or services, or a warranty or endorsement thereof. Use of TI Resources may require a license from a third party under the patents or other intellectual property of the third party, or a license from TI under the patents or other intellectual property of TI.

TI RESOURCES ARE PROVIDED "AS IS" AND WITH ALL FAULTS. TI DISCLAIMS ALL OTHER WARRANTIES OR REPRESENTATIONS, EXPRESS OR IMPLIED, REGARDING RESOURCES OR USE THEREOF, INCLUDING BUT NOT LIMITED TO ACCURACY OR COMPLETENESS, TITLE, ANY EPIDEMIC FAILURE WARRANTY AND ANY IMPLIED WARRANTIES OF MERCHANTABILITY, FITNESS FOR A PARTICULAR PURPOSE, AND NON-INFRINGEMENT OF ANY THIRD PARTY INTELLECTUAL PROPERTY RIGHTS. TI SHALL NOT BE LIABLE FOR AND SHALL NOT DEFEND OR INDEMNIFY DESIGNER AGAINST ANY CLAIM, INCLUDING BUT NOT LIMITED TO ANY INFRINGEMENT CLAIM THAT RELATES TO OR IS BASED ON ANY COMBINATION OF PRODUCTS EVEN IF DESCRIBED IN TI RESOURCES OR OTHERWISE. IN NO EVENT SHALL TI BE LIABLE FOR ANY ACTUAL, DIRECT, SPECIAL, COLLATERAL, INDIRECT, PUNITIVE, INCIDENTAL, CONSEQUENTIAL OR EXEMPLARY DAMAGES IN CONNECTION WITH OR ARISING OUT OF TI RESOURCES OR USE THEREOF, AND REGARDLESS OF WHETHER TI HAS BEEN ADVISED OF THE POSSIBILITY OF SUCH DAMAGES.

Unless TI has explicitly designated an individual product as meeting the requirements of a particular industry standard (e.g., ISO/TS 16949 and ISO 26262), TI is not responsible for any failure to meet such industry standard requirements.

Where TI specifically promotes products as facilitating functional safety or as compliant with industry functional safety standards, such products are intended to help enable customers to design and create their own applications that meet applicable functional safety standards and requirements. Using products in an application does not by itself establish any safety features in the application. Designers must ensure compliance with safety-related requirements and standards applicable to their applications. Designer may not use any TI products in life-critical medical equipment unless authorized officers of the parties have executed a special contract specifically governing such use. Life-critical medical equipment is medical equipment where failure of such equipment would cause serious bodily injury or death (e.g., life support, pacemakers, defibrillators, heart pumps, neurostimulators, and implantables). Such equipment includes, without limitation, all medical devices identified by the U.S. Food and Drug Administration as Class III devices and equivalent classifications outside the U.S.

TI may expressly designate certain products as completing a particular qualification (e.g., Q100, Military Grade, or Enhanced Product). Designers agree that it has the necessary expertise to select the product with the appropriate qualification designation for their applications and that proper product selection is at Designers' own risk. Designers are solely responsible for compliance with all legal and regulatory requirements in connection with such selection.

Designer will fully indemnify TI and its representatives against any damages, costs, losses, and/or liabilities arising out of Designer's non-compliance with the terms and provisions of this Notice.