

TG38 - 20
**Basic Part
Number**
**Dash
Number**
APPLICATION NOTES

1. Metric dimensions (mm) are indicated in parentheses.
2. Material: Aluminum alloy with electroless nickel finish.

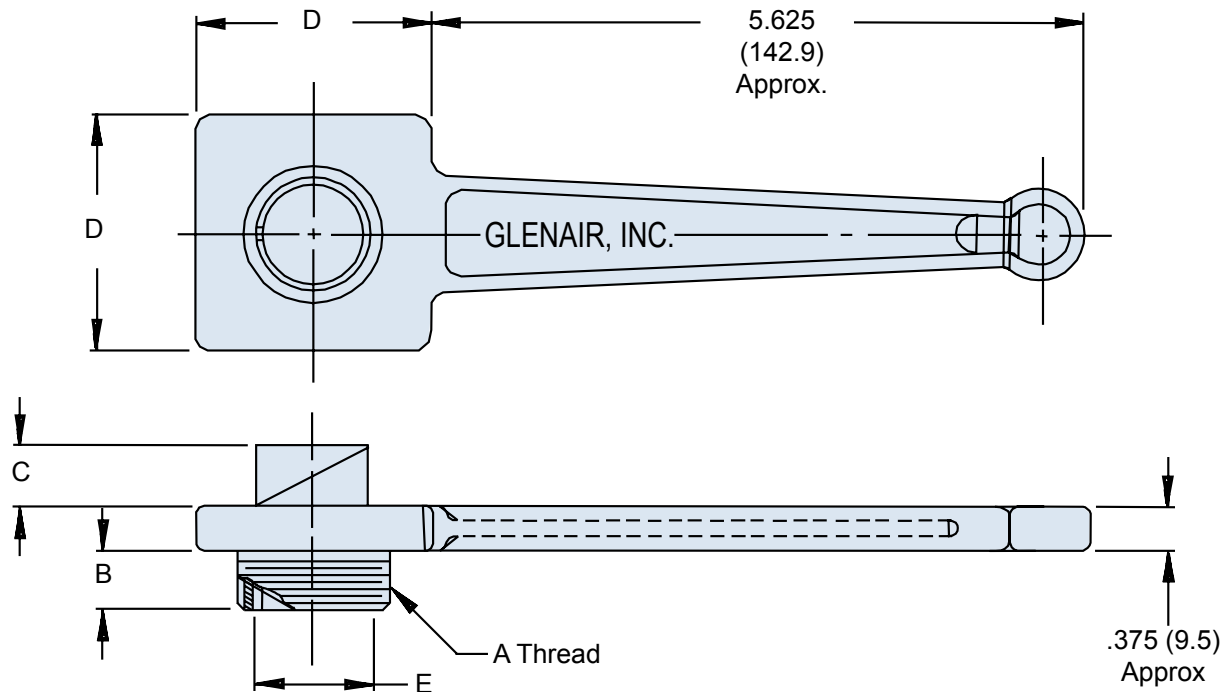

Dash No.	Shell Size	A Thread Class 2A	B Approx.	C Approx.	D Dia. ± .062 (1.6)	E Dia. Ref.
8	8, 8S	1/2 -28 UNEF	.687 (17.4)	.718 (18.2)	1.250 (31.8)	.375 (9.5)
10	10S, 10SL	5/8 -24 UNEF	.687 (17.4)	.718 (18.2)	1.250 (31.8)	.450 (11.4)
12	12, 12S	3/4 -20 UNEF	.750 (19.1)	.921 (23.4)	1.250 (31.8)	.565 (14.4)
14	14, 14S	7/8 -20 UNEF	.750 (19.1)	.921 (23.4)	1.250 (31.8)	.685 (17.4)
16	16, 16S	1 -20 UNEF	.750 (19.1)	.921 (23.4)	2.000 (50.8)	.815 (20.7)
18	18	1 1/8 -18 UNEF	.750 (19.1)	.921 (23.4)	2.000 (50.8)	.940 (23.9)
20	20	1 1/4 -18 UNEF	.750 (19.1)	.921 (23.4)	2.000 (50.8)	1.060 (26.9)
22	22	1 3/8 -18 UNEF	.750 (19.1)	.921 (23.4)	2.000 (50.8)	1.185 (30.1)
24	24	1 1/2 -18 UNEF	.750 (19.1)	.921 (23.4)	2.000 (50.8)	1.317 (33.5)
28	28	1 3/4 -18 UNS	.750 (19.1)	.921 (23.4)	2.750 (69.9)	1.530 (38.9)
32	32	2 -18 UNS	.750 (19.1)	.921 (23.4)	2.750 (69.9)	1.780 (45.2)
36	36	2 1/4 -16 UN	.750 (19.1)	.921 (23.4)	2.750 (69.9)	1.995 (50.7)
40	40	2 1/2 -16 UN	.750 (19.1)	.921 (23.4)	2.750 (69.9)	2.245 (57.0)
44	44	2 3/4 -16 UN	.750 (19.1)	.921 (23.4)	2.750 (69.9)	2.500 (63.5)
48	48	3 -16 UN	.750 (19.1)	.921 (23.4)	2.750 (69.9)	2.750 (69.9)