



Features

- Single Supply Voltage 3.0V to 4.5V
- Integrated SP3T Switch and LNA With Bypass
- Typical gain is 12dB and 1.7 dB NF in RX Mode Pin-to-Pin
- SP3T Switch Control Voltage is 2.1V to 4.5V (3.0V Typical)

Applications

- IEEE802.11b/g/n WiFi Applications
- Portable Battery-Powered Equipment
- WiFi/Bluetooth® Combination Devices

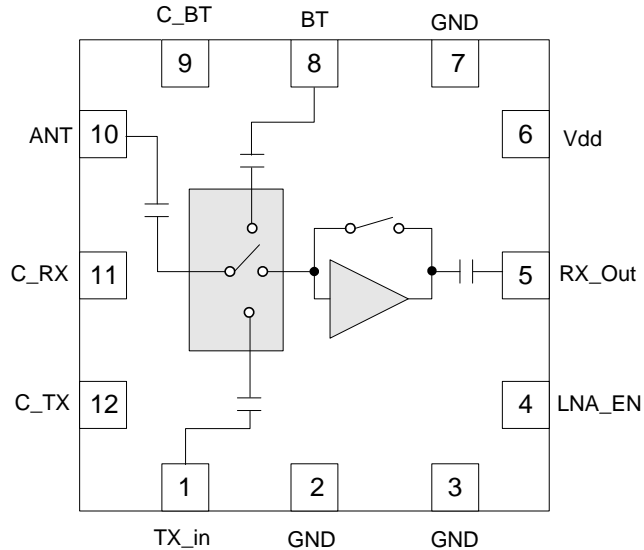

Functional Block Diagram

Product Description

The RF5611 is designed specifically for high-performance WiFi applications in the 2.4GHz to 2.5GHz ISM band, including Personal Media Players (PMPs), digital cameras, and WiFi enabled handsets. The RF5611 integrates the LNA with bypass and the SP3T switch of a Front-End solution for WiFi and Bluetooth® combination systems. The integrated match and DC blocking capacitors on all RF Ports reduce the number of external components, keeping cost down and utilizing minimum layout area for implementation. The RF5611 is provided in a 2mmx2mmx0.5mm, 12-pin QFN package. This LNA + Switch front-end solution meets or exceeds the specification requirements of IEEE 802.11 b/g/n WiFi RF systems.

Ordering Information

RF5611	Standard 25 piece bag
RF5611SR	Standard 100 piece reel
RF5611TR7	Standard 2500 piece reel
RF5611PCK-410	Fully Assembled Evaluation Board

Optimum Technology Matching® Applied

- | | | | |
|--------------------------------------|--------------------------------------|--|-----------------------------------|
| <input type="checkbox"/> GaAs HBT | <input type="checkbox"/> SiGe BiCMOS | <input checked="" type="checkbox"/> GaAs pHEMT | <input type="checkbox"/> GaN HEMT |
| <input type="checkbox"/> GaAs MESFET | <input type="checkbox"/> Si BiCMOS | <input type="checkbox"/> Si CMOS | |
| <input type="checkbox"/> InGaP HBT | <input type="checkbox"/> SiGe HBT | <input type="checkbox"/> Si BJT | |

RF MICRO DEVICES®, RFMD®, Optimum Technology Matching®, Enabling Wireless Connectivity™, PowerStar®, POLARIS™ TOTAL RADIO™ and UltimateBlue™ are trademarks of RFMD, LLC. BLUETOOTH is a trademark owned by Bluetooth SIG, Inc., U.S.A. and licensed for use by RFMD. All other trade names, trademarks and registered trademarks are the property of their respective owners. ©2006, RF Micro Devices, Inc.

Absolute Maximum Ratings

Parameter	Rating	Unit
DC Supply Voltage	5.5	V
Full Spec Compliant Temperature Range	-10 to +75	°C
Storage Temperature	-40 to +150	°C
Antenna Port Nominal Impedance	50	Ω
Ruggedness Output VSWR	10:1	
Stability Output VSWR	5:1	
ESD - Human Body Model	500	V
ESD - CDM	650	V
LNA Input Power (no damage)	5	dBm
Moisture Sensitivity	MSL2	



Caution! ESD sensitive device.

Exceeding any one or a combination of the Absolute Maximum Rating conditions may cause permanent damage to the device. Extended application of Absolute Maximum Rating conditions to the device may reduce device reliability. Specified typical performance or functional operation of the device under Absolute Maximum Rating conditions is not implied.

RoHS status based on EU Directive 2002/95/EC (at time of this document revision).

The information in this publication is believed to be accurate and reliable. However, no responsibility is assumed by RF Micro Devices, Inc. ("RFMD") for its use, nor for any infringement of patents, or other rights of third parties, resulting from its use. No license is granted by implication or otherwise under any patent or patent rights of RFMD. RFMD reserves the right to change component circuitry, recommended application circuitry and specifications at any time without prior notice.

Parameter	Specification			Unit	Condition
	Min.	Typ.	Max.		
Compliance					IEEE802.11b, IEEE802.11g FCC CFR 15.247, .205, .209, EN & JDEC. V _{DD} =3.3V, LNA EN=2.85V, Temp = +25 °C, Freq = 2.4GHz to 2.5GHz, unless noted otherwise.
Operating Frequency	2.4		2.5	GHz	
LNA Voltage Supply (V _{DD})	3.0	3.3	4.5	V	
LNA Enable Voltage (LNA_EN)	2.7	2.85	4.5	V	LNA Enabled
			0.2	V	LNA Off
Switch Control Voltage "HIGH"	2.4			V	C_RX, C_TX, C_BT
Switch Control Voltage "LOW"			0.2	V	C_RX, C_TX, C_BT
LNA Bypass (LNA_EN)	2.7		4.5	V	LNA Bypass Disabled
			0.2	V	LNA Bypass Enabled
Current Consumption					
LNA V _{DD}		8.5	12.5	mA	LNA in "On" state
			10	μA	LNA in "Off" state
LNA Enable		0.7	1.1	mA	LNA Enabled
LNA Bypass			10	uA	LNA Bypass Mode
Switch Controls			10	uA	1-3uA per control line
Gain					
WiFi Receive Only	9.5	12		dB	C_RX _{HI} , C_TX _{LO} , C_BT _{LO} , LNA_EN _{HI}
Simultaneous WiFi/TB Receive (note 4)	6.5			dB	Measured at RX OUT (LNA_EN _{HI} , C_RX _{HI} , C_BT _{HI} , C_TX _{LO})
	-4.5			dB	Measured at BT Port (LNA_EN _{HI} , C_RX _{HI} , C_BT _{HI} , C_TX _{LO})
Insertion Loss					
WiFi Bypass Mode Only		3.5	5	dB	C_RX _{HI} , C_TX _{LO} , C_BT _{LO} , LNA_EN _{LO}
BT Receive Only		1.1	1.5	dB	C_BT _{HI} , C_RX _{LO} , C_TX _{LO} , LNA_EN _X
Simultaneous WiFi/BT Bypass (note 4)			8	dB	Measured at RX OUT (LNA_EN _{LO} , C_RX _{HI} , C_BT _{HI} , C_TX _{LO})
			5.5	dB	Measured at BT Port (LNA_EN _{LO} , C_RX _{HI} , C_BT _{HI} , C_TX _{LO})

Parameter	Specification			Unit	Condition
	Min.	Typ.	Max.		
Noise Figure					
WiFi Rx Mode Only		2.2	2.8	dB	Including switch, LNA EN _{HI}
BT RX Only		1.1	1.5	dB	
Simultaneous WiFi/BT RX (note 4)			5.5	dB	Measured at RX OUT (LNA EN _{HI} , C RX _{HI} , C BT _{HI} , C TX _{LO})
Return Loss					
WiFi RX Mode Only	5			dB	Measured at RX OUT
BT RX Only		10		dB	Measured at BT Port
Transmit Port		10		dB	Measured at TX IN
Antenna Port (WiFi RX Mode)	5			dB	Measured at ANT Port under load conditions
Other Parameters					
Input/Output Impedance		50		Ω	All RF Ports (note 2)
Passband Ripple	-0.2		+0.2	dB	All modes
Switch P1dB		28		dBm	
Isolation TX to BT	25	28		dB	Measured at BT port while in TX Mode (C_TX=2.8V, LNA_EN=0V, C_RX=0V, C_BT=0V)
TX to RX	20			dB	Measured at RX port while in TX Mode (C_TX=2.8V, LNA_EN=0V, C_RX=0V, C_BT=0V)
Switch Control Speed		50		ns	(note 1)

Note 1: The switch must operate with gated bias voltage input at 1% to 99% duty cycle.

Note 2: No external matching components.

Note 3: Values to be agreed to upon characterization data review.

Note 4: The FEM can be placed in transmit/receive WiFi and Bluetooth modes simultaneously with increased insertion loss.

Switch Control Logic

MODE	Switch Controls			
	C BT	C RX	C TX	LNA EN
WL RX only	LOW	HIGH	LOW	HIGH
WL RX Bypass	LOW	HIGH	LOW	LOW
BT only	HIGH	LOW	LOW	LOW
TX only	LOW	LOW	HIGH	LOW
Simultaneous WL/BT RX	HIGH	HiGH	LOW	HIGH

Pin	Function	Description
1	TX IN	RF input for the 802.11b/g PA. TX port includes integrated DC-block and 50Ω match.
2	GND	Ground.
3	GND	Ground.
4	LNA EN	This pin enables the LNA. A logic HIGH enables the LNA.
5	RX OUT	Receive port for 802.11b/g band. RX output includes integrated DC-block and 50Ω match.
6	VDD	Supply voltage to the LNA.
7	GND	Ground.
8	BT	RF bidirectional port for Bluetooth™. BT port includes integrated DC-block and 50Ω match.
9	C BT	Bluetooth™ mode control voltage. See switch truth table for proper level.
10	ANT	This is the common port (antenna). Antenna port includes integrated DC-block and 50Ω match.
11	C RX	Receive mode control voltage. See switch truth table for proper level.
12	C TX	Transmit mode control voltage. See switch truth table for proper level.

Package Drawing

Top View

Note: Pads are NiPdAu plated.

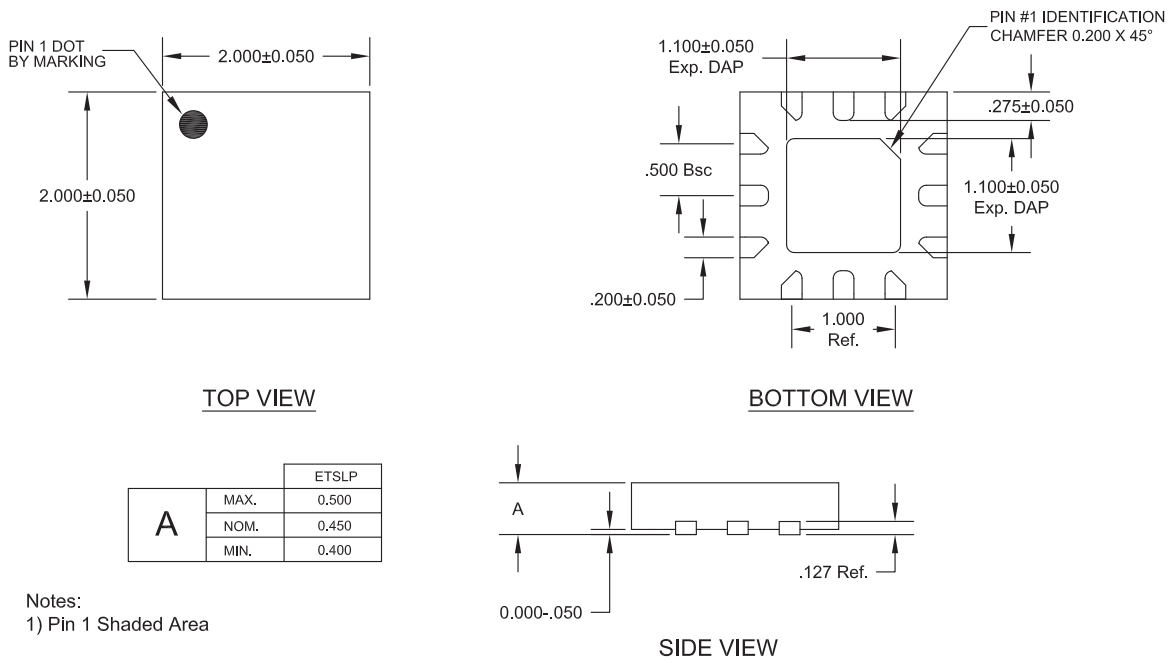

RF5611 PCB Footprint and Stencil Recommendations

A = 0.250 x 0.402 (mm) Typ
 B = 0.402 x 0.250 (mm) Typ
 C = 0.250 x 0.402 (mm) 60% Rounded Rectangle
 D = 0.402 x 0.250 (mm) 60% Rounded Rectangle
 E = 1.050 x 1.050 (mm)

A = 0.350 x 0.502 (mm) Typ
 B = 0.502 x 0.350 (mm) Typ
 C = 0.350 x 0.502 (mm) 60% Rounded Rectangle
 D = 0.502 x 0.350 (mm) 60% Rounded Rectangle
 E = 1.150 x 1.150 (mm)

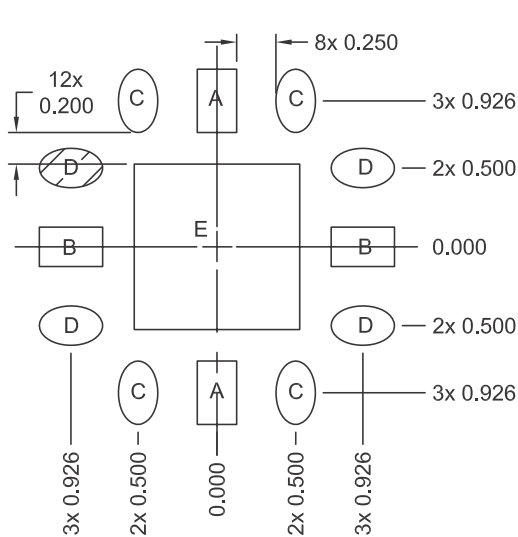

PCB METAL PATTERN

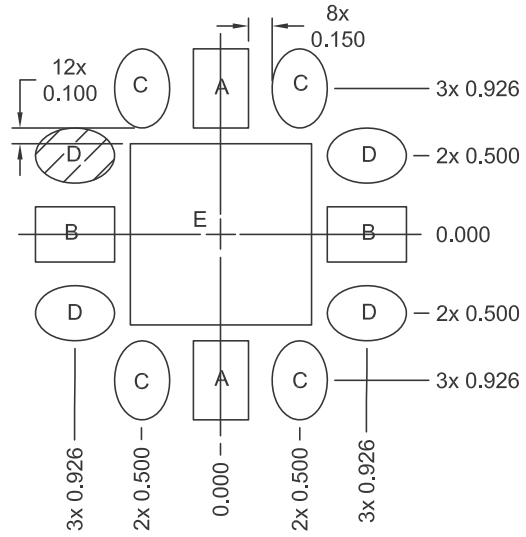

PCB SOLDER MASK PATTERN

A = 0.225 x 0.362 (mm)
 B = 0.362 x 0.225 (mm)
 C = 0.225 x 0.362 (mm) 60% Rounded Rectangle
 D = 0.362 x 0.225 (mm) 60% Rounded Rectangle
 E = 0.945 x 0.945 (mm)

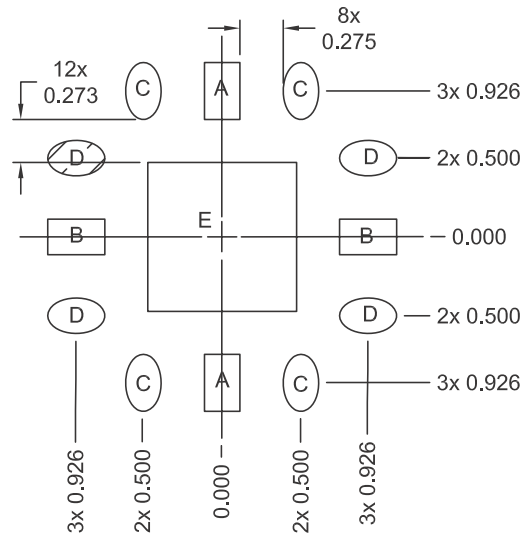

PCB STENCIL PATTERN

Shaded are represents Pin 1 location.

Pin Out Top View

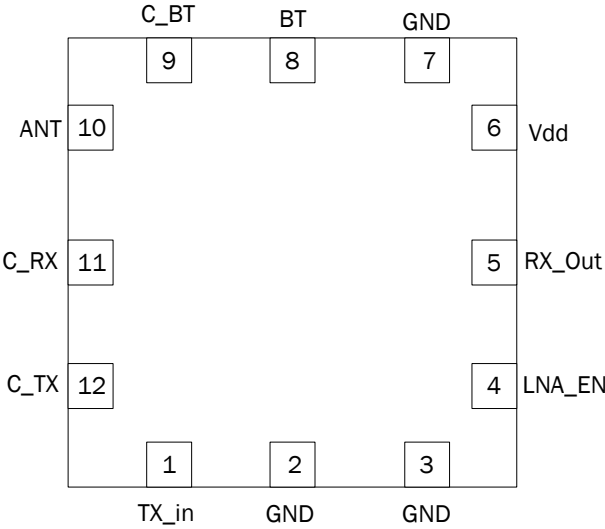

Evaluation Board Schematic

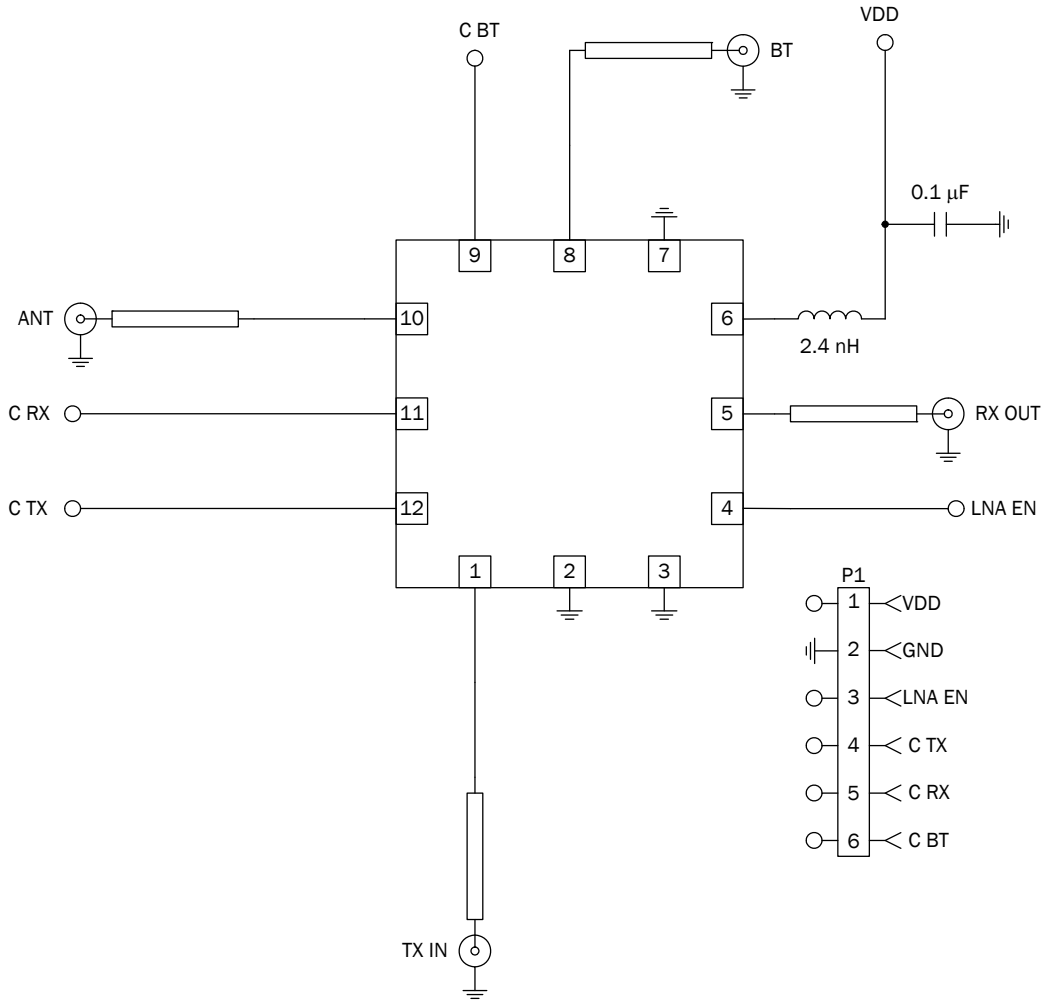

Evaluation Board Layout Board Size 1.5" x 1.5"

Board Thickness 0.032", Board Material FR-4, Multi-layer

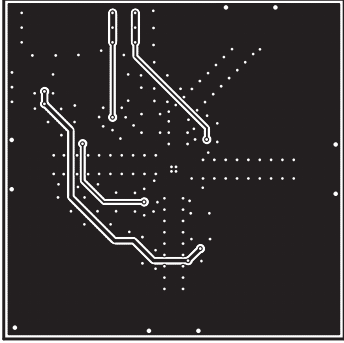
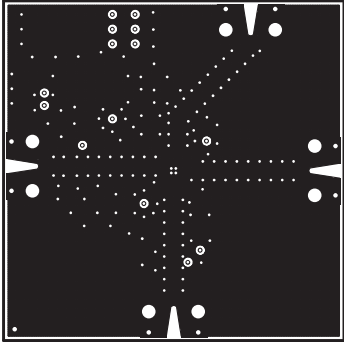
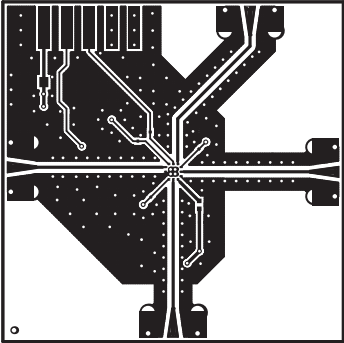
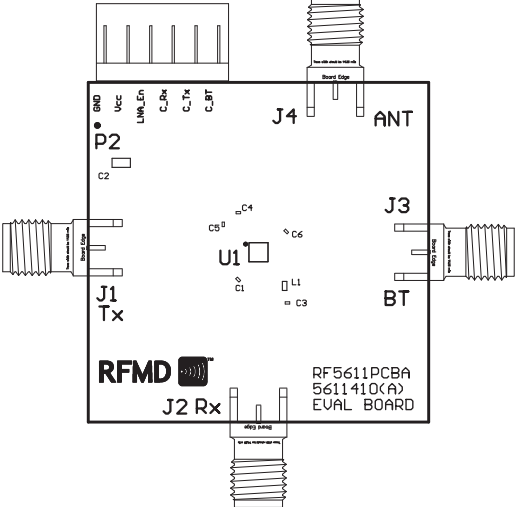

Performance Plots

RF5611: GAIN versus FREQUENCY and TEMPERATURE
(Vdd=3.3v, LNA_EN=2.8v, C_RX=2.8v, C_TX=0v, C_BT=0v)

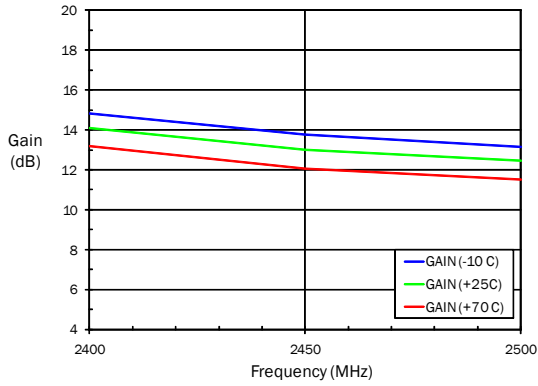

RF5611: NF versus FREQUENCY and TEMPERATURE
(Vdd=3.3v, LNA_EN=2.8v, C_RX=2.8v, C_TX=0v, C_BT=0v)

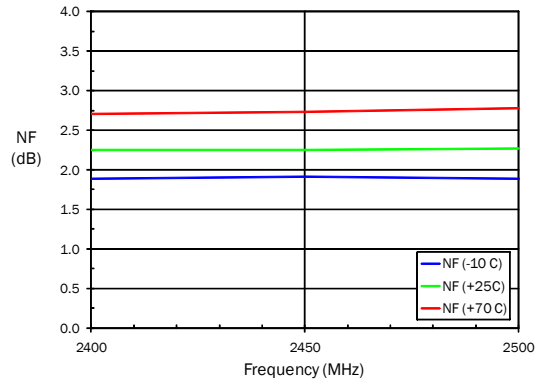

RF5611: INPUT IP3 versus FREQUENCY and TEMPERATURE
(Vdd=3.3v, LNA_EN=2.8v, C_RX=2.8v, C_TX=0v, C_BT=0v)

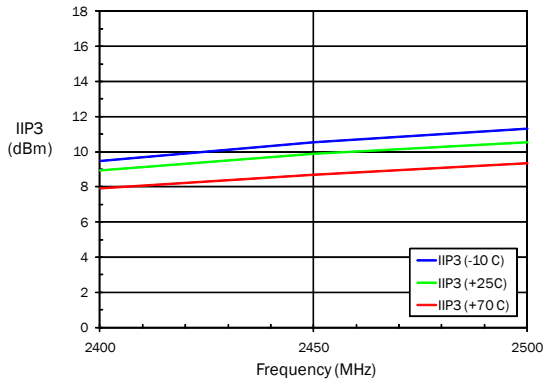

RF5611: CURRENT versus FREQUENCY and TEMPERATURE
(Vdd=3.3v, LNA_EN=2.8v, C_RX=2.8v, C_TX=0v, C_BT=0v)

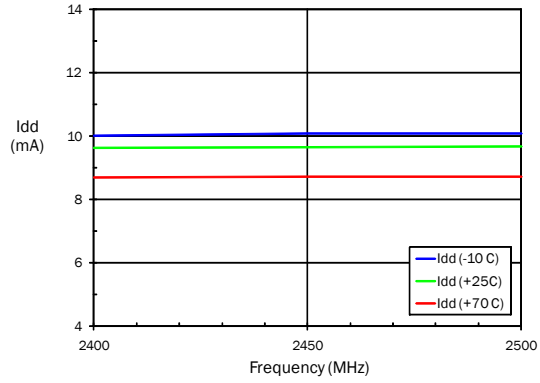

RF5611: BYPASS MODE INSERTION LOSS versus FREQUENCY and TEMPERATURE
(Vdd=3.3v, C_RX=2.8v, LNA_EN=0v, C_TX=0v, C_BT=0v)

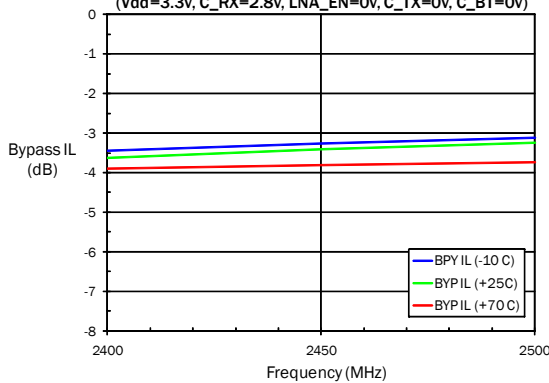

RF5611: TRANSMIT MODE INSERTION LOSS versus FREQUENCY and TEMPERATURE
(Vdd=3.3v, C_TX=2.8v, C_RX=0v, C_BT=0v)

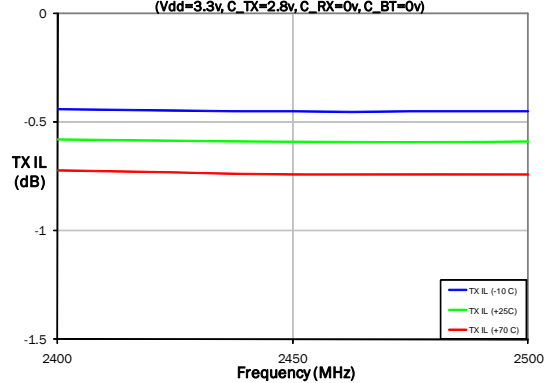

RF5611: BLUETOOTH MODE INSERTION LOSS versus FREQUENCY and TEMPERATURE
(Vdd=3.3v, C_BT=2.8v, C_RX=0v, C_TX=0v)

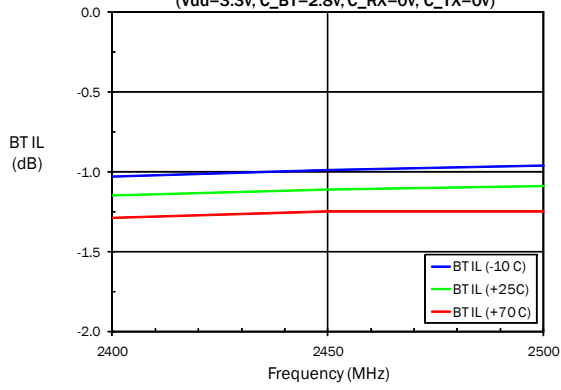

RF5611: TRANSMIT TO RECEIVE ISOLATION versus FREQUENCY and TEMPERATURE
(Vdd=3.3v, C_TX=2.8v, LNA_EN=0v, C_RX=0v, C_BT=0v)

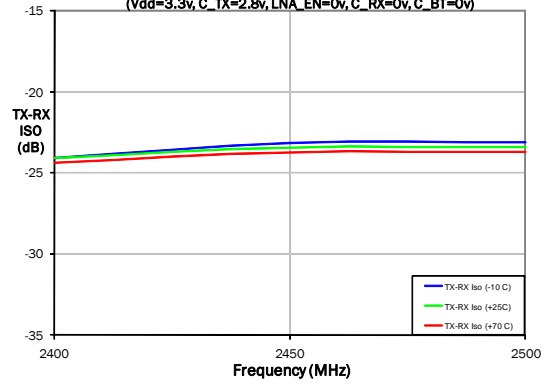

RF5611: TRANSMIT TO BLUETOOTH ISOLATION versus FREQUENCY and TEMPERATURE
(Vdd=3.3v, C_TX=2.8v, C_RX=0v, C_BT=0v)

