

Features

- Compliant with AEC-Q200 Rev-C-Stress Test Qualification for Passive Components in Automotive Applications
- Operating temperature range up to 125 °C
- Low thermal derating factor
- Higher hold currents at elevated temperature
- Choice of operating currents
- RoHS compliant* and halogen free**
- Resettable fault protection of general electronic equipment

PRCP-RHT Series - Polymer Resettable Circuit Protectors

Electrical Characteristics

Model	V max. Volts	I max. Amps	I _{hold}	I _{trip}	Resistance		Max. Time To Trip		Tripped Power Dissipation
			Amperes at 23 °C		Ohms at 23 °C		Amperes at 23 °C	Seconds at 23 °C	Watts at 23 °C
			Hold	Trip	R _{Min.}	R _{1Max.} (Post Trip)		Max.	Typ.
PRCP-RHT070	16	40	0.7	1.4	0.3	0.8	3.5	4.0	1.4
PRCP-RHT200	16	100	2.0	3.8	0.045	0.110	12.5	3.0	1.4
PRCP-RHT450	16	100	4.5	7.8	0.022	0.054	22.5	3.0	3.6
PRCP-RHT650	16	100	6.5	12.0	0.011	0.026	32.5	5.5	4.3
PRCP-RHT750	16	100	7.5	13.1	0.0094	0.022	37.5	7.0	4.5
PRCP-RHT1300	16	100	13.0	24.0	0.0041	0.010	60.0	13.0	6.9

Environmental Characteristics

Operating Temperature.....-40 °C to +125 °C
 Storage Temperature.....-40 °C to +85 °C
 Passive Aging.....+85 °C, 1000 hours..... ±15 % typical resistance change
 Humidity Aging.....+85 °C, 85 % R.H. 1000 hours..... ±15 % typical resistance change
 Thermal Shock.....MIL-STD-202, Method 107, +125 °C to -40 °C, 10 cycles..... ±10 % typical resistance change
 Vibration.....MIL-STD-883C, Method 2007.1, Condition A..... No change

Test Procedures And Requirements For Model PRCP-RHT Series

Test	Test Conditions	Accept/Reject Criteria
Visual/Mech.....	Verify dimensions and materials.....	Per PRCP physical description
Resistance.....	In still air @ 23 °C.....	R _{min} ≤ R ≤ R _{1max}
Time to Trip.....	At specified current. V _{max} . 23 °C.....	T ≤ max. time to trip (seconds)
Hold Current.....	30 min. at I _{hold}	No trip
Trip Cycle Life.....	V _{max} , I _{max} , 100 cycles.....	No arcing or burning
Trip Endurance.....	V _{max} , 48 hours.....	No arcing or burning
Solderability.....	MIL-STD-202, Method 208.....	95 % min. coverage

Thermal Derating Chart - I_{hold} (Amps)

Model	Ambient Operating Temperature									
	-40 °C	-20 °C	0 °C	23 °C	40 °C	50 °C	60 °C	70 °C	85 °C	125 °C
PRCP-RHT070	0.95	0.87	0.79	0.7	0.62	0.56	0.51	0.47	0.39	0.17
PRCP-RHT200	2.71	2.49	2.26	2.00	1.77	1.60	1.46	1.34	1.11	0.49
PRCP-RHT450	6.1	5.6	5.1	4.5	4.0	3.6	3.3	3.0	2.5	1.1
PRCP-RHT650	8.8	8.1	7.4	6.5	5.7	5.3	4.8	4.3	3.6	1.6
PRCP-RHT750	10.2	9.4	8.6	7.5	6.6	6.1	5.6	5.0	4.1	1.9
PRCP-RHT1300	17.7	16.3	14.8	13.0	11.4	10.5	9.6	8.6	7.2	3.3

How to Order

PRCP - RHT 750 -

Product Designator _____

Series _____
 RHT = High Temperature
 Radial Leaded Component

Hold Current, I_{hold} _____
 070 - 1300 (0.70 - 13.00 Amps)

Packaging Options _____
 - = Bulk Packaging
 - 2 = Tape and Reel*

*Packaged per EIA 486-B

*RoHS Directive 2002/95/EC Jan 27 2003 including annex and RoHS Recast 2011/65/EU June 8,2011.
 **COPAL follows the prevailing definition of "halogen free" in the industry. COPAL considers a product to be "halogen free" if (a) the Bromine (Br) content is 900 ppm or less; (b) the Chlorine (Cl) content is 900 ppm or less; and (c) the total Bromine (Br) and Chlorine (Cl) content is 1500 ppm or less.
 Specifications are subject to change without notice.
 The device characteristics and parameters in this data sheet can and do vary in different applications and actual device performance may vary over time.
 Customers should verify actual device performance in their specific applications.

Applications

- Protection of automotive circuitry including engine control modules
- Overcurrent surge protection of electronic equipment required to operate at high operating temperature ranges
- Resettable fault protection of general electronic equipment

PRCP-RHT Series - Polymer Resettable Circuit Protectors

COPAL ELECTRONICS

Product Dimensions

Model	A		B		C		D		E		F		Physical Characteristics	
	Max.	Max.	Nom.	Tol. ±	Min.	Max.	Nom.	Style	Material					
PRCP-RHT070	6.86 (0.27)	10.8 (0.425)	5.1 (0.201)	0.7 (0.028)	7.6 (0.30)	3.0 (0.12)	0.51 (0.020)	1	Sn/CuFe					
PRCP-RHT200	9.4 (0.37)	14.0 (0.55)	5.1 (0.201)	0.7 (0.028)	7.6 (0.30)	3.0 (0.12)	0.51 (0.020)	3	Sn/Cu					
PRCP-RHT450	10.4 (0.41)	15.6 (0.61)	5.1 (0.201)	0.7 (0.028)	7.6 (0.30)	3.0 (0.12)	0.81 (0.032)	2	Sn/Cu					
PRCP-RHT650	12.7 (0.50)	22.2 (0.88)	5.1 (0.201)	0.7 (0.028)	7.6 (0.30)	3.0 (0.12)	0.81 (0.032)	2	Sn/Cu					
PRCP-RHT750	14.0 (0.55)	23.5 (0.93)	5.1 (0.201)	0.7 (0.028)	7.6 (0.30)	3.0 (0.12)	0.81 (0.032)	2	Sn/Cu					
PRCP-RHT1300	23.5 (0.925)	28.7 (1.17)	10.2 (0.402)	0.7 (0.028)	7.6 (0.30)	3.6 (0.14)	1.0 (0.040)	2	Sn/Cu					

0.51 (24AWG)
0.81 (20AWG)
1.0 (18AWG)
DIMENSIONS: $\frac{\text{MM}}{\text{(INCHES)}}$

Packaging:

BULK: 500 pcs. per bag

TAPE & REEL: PRCP-RHT070 ~ PRCP-RHT200 = 3000 pcs. per reel; PRCP-RHT450 ~ PRCP-RHT650 = 1500 pcs. per reel;
PRCP-RHT750 ~ PRCP-RHT1300 = 1000 pcs. per reel

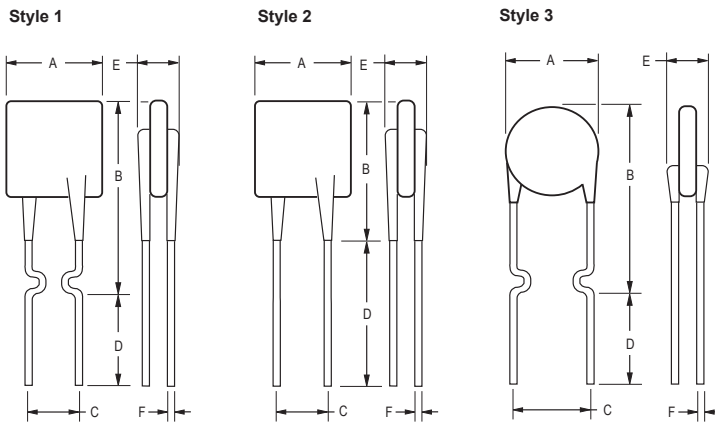

Typical Part Marking

Represents total content. Layout may vary.

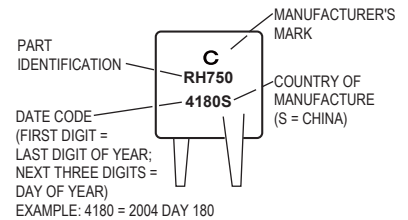

Typical Time to Trip at 23 °C

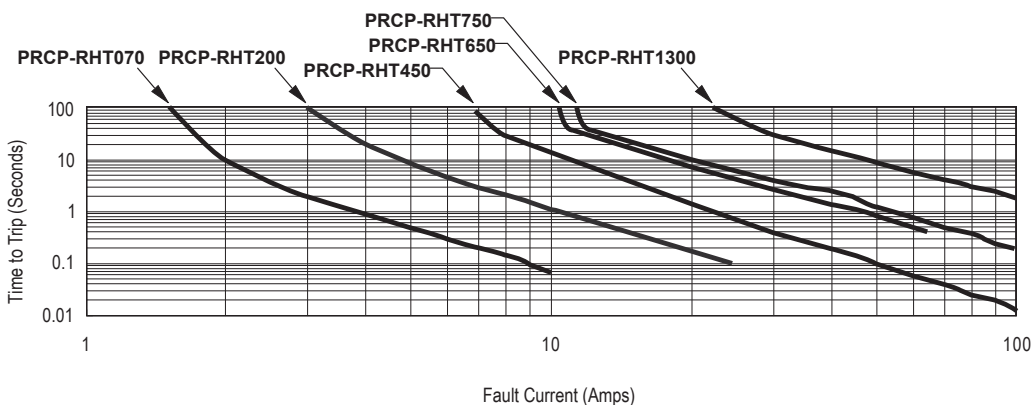

The Time to Trip curves represent typical performance of a device in a simulated application environment. Actual performance in specific customer applications may differ from these values due to the influence of other variables.

Specifications are subject to change without notice. The device characteristics and parameters in this data sheet can and do vary in different applications and actual device performance may vary over time. Customers should verify actual device performance in their specific applications.

PRCP-RHT Series Tape and Reel Specifications

COPAL ELECTRONICS

Devices taped using EIA468–B/IEC60286-2 standards. See table below and Figures 1 and 2 for details.

Dimension Description	IEC Mark	EIA Mark	Dimensions	
			Dimensions	Tolerance
Carrier tape width	W	W	$\frac{18}{(.709)}$	$\frac{-0.5/+1.0}{(-0.02/+0.039)}$
Hold down tape width	W ₀	W ₄	$\frac{11}{(.433)}$	min.
Hold down tape			No protrusion	
Top distance between tape edges	W ₂	W ₆	$\frac{3}{(.118)}$	max.
Sprocket hole position	W ₁	W ₅	$\frac{9}{(.354)}$	$\frac{-0.5/+0.75}{(-0.02/+0.03)}$
Sprocket hole diameter	D ₀	D ₀	$\frac{4}{(.157)}$	$\frac{\pm 0.2}{(\pm .0078)}$
Abscissa to plane (straight lead)	H	H	$\frac{18.5}{(.728)}$	$\frac{\pm 3.0}{(\pm .118)}$
Abscissa to plane (kinked lead)	H ₀	H ₀	$\frac{16}{(.63)}$	$\frac{\pm 0.5}{(\pm .02)}$
Abscissa to top: PRCP-RHT070 ~ PRCP-RHT450	H ₁	H ₁	$\frac{32.2}{(1.268)}$	max.
Abscissa to top: PRCP-RHT650 ~ PRCP-RHT1300	H ₁	H ₁	$\frac{45.0}{(1.837)}$	max.
Overall width w/lead protrusion: PRCP-RHT070 ~ PRCP-RHT450		C ₁	$\frac{42.5}{(1.673)}$	max.
Overall width w/lead protrusion: PRCP-RHT650 ~ PRCP-RHT1300		C ₁	$\frac{55.0}{(2.165)}$	max.
Overall width w/o lead protrusion: PRCP-RHT070 ~ PRCP-RHT450		C ₂	$\frac{42.5}{(1.673)}$	max.
Overall width w/o lead protrusion: PRCP-RHT650 ~ PRCP-RHT1300		C ₂	$\frac{54.0}{(2.126)}$	max.
Lead protrusion	I ₁	L ₁	$\frac{1.0}{(.039)}$	max.
Protrusion of cutout	L	L	$\frac{11}{(.433)}$	max.
Protrusion beyond hold-down tape	I ₂	I ₂	Not specified	
Sprocket hole pitch	P ₀	P ₀	$\frac{12.7}{(0.5)}$	$\frac{\pm 0.3}{(\pm .012)}$
Pitch tolerance			20 consecutive	$\frac{\pm 1}{(\pm .039)}$
Device pitch: PRCP-RHT070 ~ PRCP-RHT450			$\frac{12.7}{(0.5)}$	$\frac{\pm 0.3}{(\pm .012)}$
Device pitch: PRCP-RHT650 ~ PRCP-RHT1300			$\frac{25.4}{(1.0)}$	$\frac{\pm 0.6}{(\pm .024)}$
Tape thickness	t	t	$\frac{0.9}{(.035)}$	max.
Tape thickness with splice: PRCP-RHT070		t ₁	$\frac{1.5}{(.059)}$	max.
Tape thickness with splice: PRCP-RHT450 ~ PRCP-RHT1300		t ₁	$\frac{2.3}{(.091)}$	max.
Splice sprocket hole alignment			$\frac{4.0}{(.157)}$	$\frac{\pm 0.2}{(\pm .008)}$
Body lateral deviation	Δ _h	Δ _h	0	$\frac{\pm 1}{(\pm .039)}$
Body tape plane deviation	Δ _p	Δ _p	0	$\frac{\pm 0.3}{(\pm .012)}$
Ordinate to adjacent component lead	P ₁	P ₁	$\frac{3.81}{(.015)}$	$\frac{\pm 0.07}{(\pm .028)}$

DIMENSIONS: $\frac{\text{MM}}{\text{(INCHES)}}$

Specifications are subject to change without notice.

The device characteristics and parameters in this data sheet can and do vary in different applications and actual device performance may vary over time. Customers should verify actual device performance in their specific applications.

PRCP-RHT Series Tape and Reel Specifications

COPAL ELECTRONICS

Dimension Description	IEC Mark	EIA Mark	Dimensions	
			Dimensions	Tolerance
Lead spacing: PRCP-RHT070 ~ PRCP-RHT750	F	F	$\frac{5.08}{(0.2)}$	$\frac{-0.2/+0.8}{(-0.006/+0.031)}$
Lead spacing: PRCP-RHT1300	F	F	$\frac{10.2}{(0.402)}$	$\frac{-0.2/+0.8}{(-0.006/+0.031)}$
Reel width: PRCP-RHT070 ~ PRCP-RHT450	w	W ₂	$\frac{56}{(2.20)}$	max.
Reel width: PRCP-RHT650 ~ PRCP-RHT1300	w	W ₂	$\frac{63.5}{(2.50)}$	max.
Reel diameter	d	a	$\frac{370.0}{(14.57)}$	max.
Space between flanges less device	W ₁	h	$\frac{4.75}{(.187)}$	$\frac{±3.25}{(±.128)}$
Arbor hole diameter	f	c	$\frac{26.0}{(1.02)}$	$\frac{±12.0}{(±.472)}$
Core diameter	h	n	$\frac{80.0}{(3.15)}$	max.
Box			$\frac{62}{(2.44)}$ $\frac{355}{(14.0)}$ $\frac{345}{(13.6)}$	
Consecutive missing places			3	max.
Empty places per reel			Not specified	

Taped Component Dimensions - Figure 1

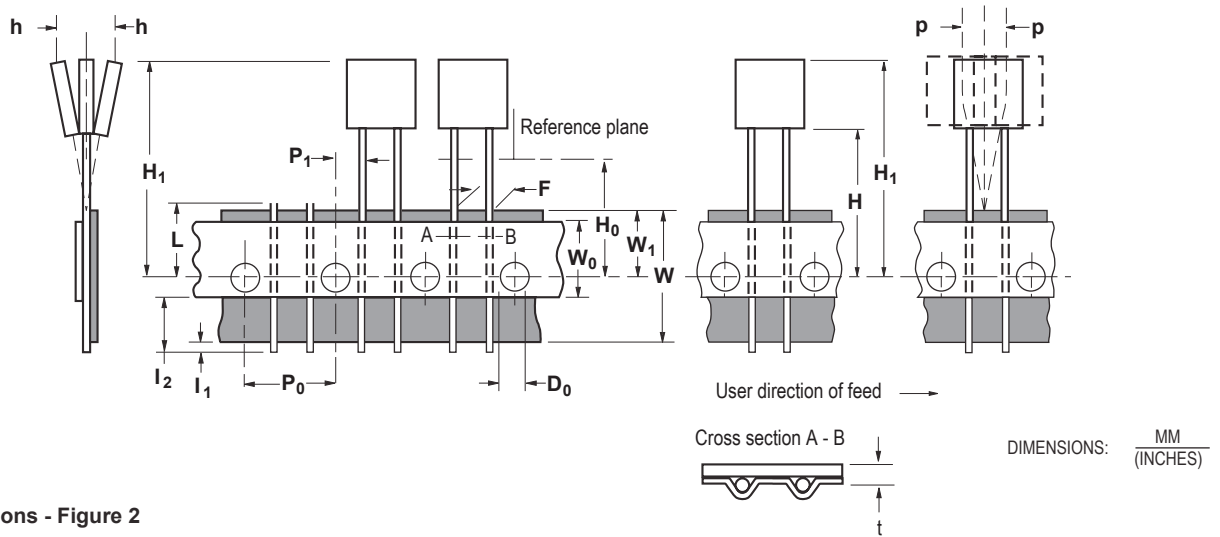

Reel Dimensions - Figure 2

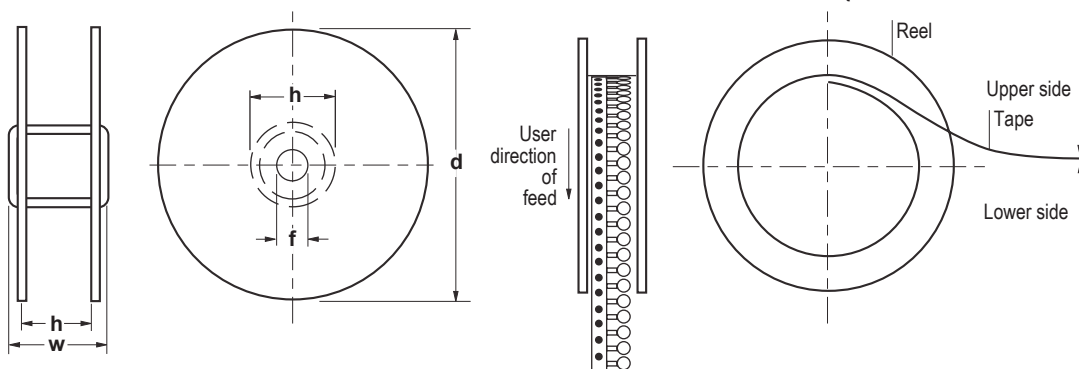

Specifications are subject to change without notice.
 The device characteristics and parameters in this data sheet can and do vary in different applications and actual device performance may vary over time.
 Customers should verify actual device performance in their specific applications.

Revision History

Date	Rev.	Reason
12/13/2005	A	Initial issue
08/31/2012	B	Updated Product Dimensions
10/02/2013	C	Updated Tape and Reel Specifications
06/04/2015	D	Updated Features (Added halogen free)

Revision : D
Issue date : 06/04/15

PRCP-RHT SERIES