

ITEM	DESC.	Q'TY	MATERIALS	TREATMENT	REMARK
1.	METAL STEM	1	BRASS	NICKEL PLATED	-
2.	COVER	1	<input type="checkbox"/> =NICKEL SILVER S = STAINLESS STEEL	<input type="checkbox"/> =NONE S =WITH SILVER PLATING	-
3.	ADHESIVE TAPE	1	TEFLON	NONE	-
4.	TERMINAL	1	PHOSPHOR BRONZE	WITH SILVER PLATING	-
5.	CONTACT	1	STAINLESS STEEL	WITH SILVER CLADDING	-
6.	BASE	1	HIGH - TEMP THERMOPLASTIC LCP	MOLDED BLACK	-

T - 5 - - V -

Package:

T/R=Tape & Reel

ROHS & Lead Free Solderable

=STAINLESS STEEL
S =STAINLESS STEEL

Operating Force:

2=100g

3=160g

4=260g

Total H:

2=0.8mm

3=1.5mm

5x5mm

=Cover Nickel Silver
S =Cover Stainless steel

Prod. Series:

G=With Ground Terminals

E = Ground pin in Central

TERMINATION TYPE:

M = Gull Wing

J = J Bend

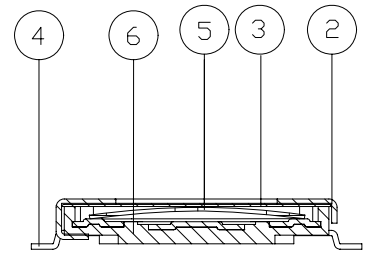

TMG-52*



TJE-52

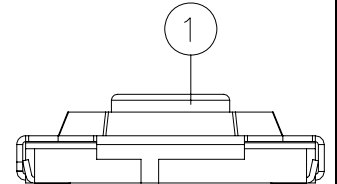

TJG-53

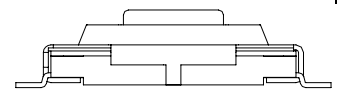

TJE-53

C	依技通 09007 執行變更	
B	上蓋新增不銹鋼鍍銀 材質	邱明義
A	DWG.REL.	邱明義
RVE.	ECO NO.	APPD.

TITLE:	APPD :
TACTILE SWITCH TYPE	CHKD.:
PROD. NO. : T <input type="checkbox"/> <input type="checkbox"/> <input type="checkbox"/> - 5 <input type="checkbox"/> <input type="checkbox"/> - <input type="checkbox"/> - V - <input type="checkbox"/>	PR : PAGGY
FILE NO. : E-V-CT16	REV:C SHEET:1of1

A 10 9 8 7 6 5 4 3 2 1

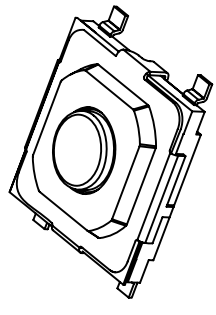

TMG-53*

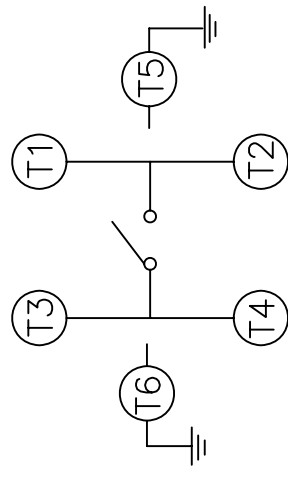
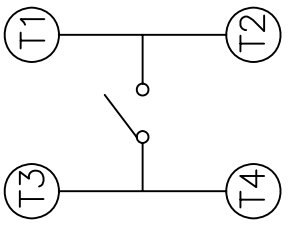
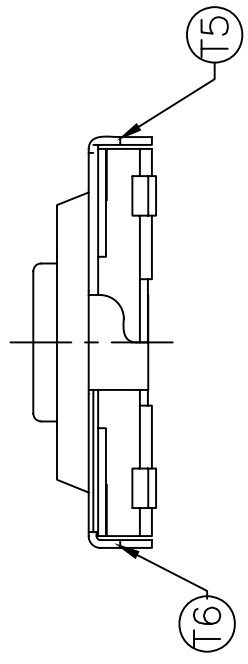
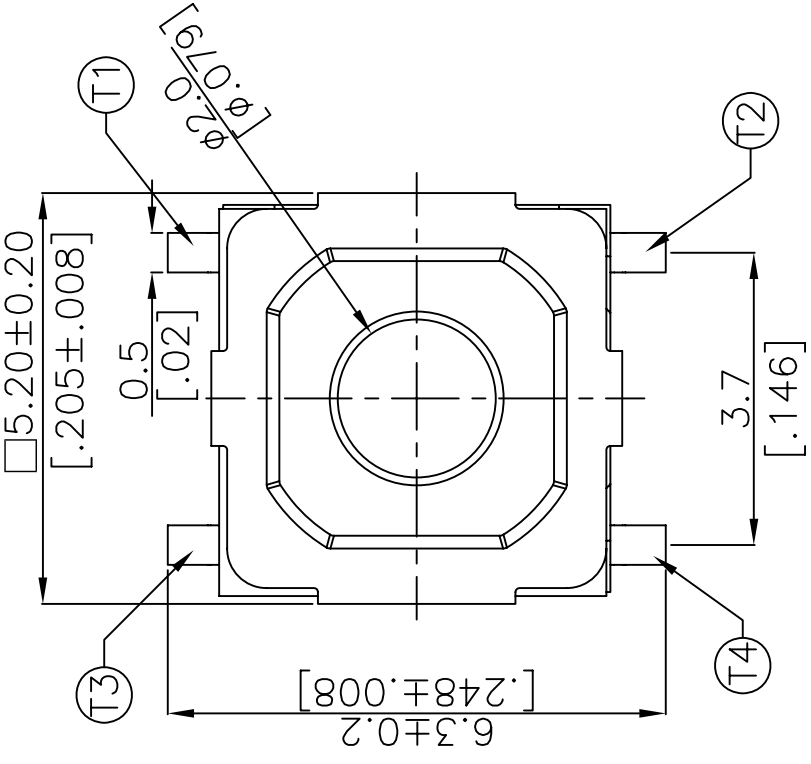
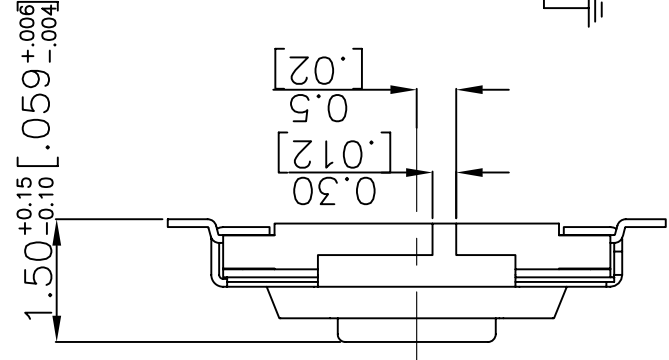

WITH GROUND
CIRCUIT DIAGRAM

WITHOUT GROUND
CIRCUIT DIAGRAM

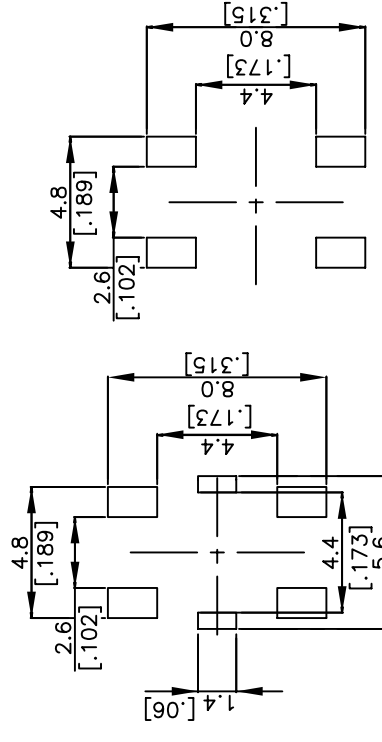

WITH GROUND
P.C.B LAYOUT

WITHOUT GROUND
P.C.B LAYOUT

NOTE:

1. ALL DIMENSIONS ARE IN MILLIMETERS. BRACKETED DIMENSIONS ARE IN INCHES.
2. GENERAL TOLERANCES ± 0.20 [0.008] mm.

Table 1

PART NO	OF
TMG-531-V	70gf
TMG-532-V	100gf
TMG-533-V	160gf
TMG-534-V	260gf

ZONE	REV.	DESCRIPTION	DATE	APPD.
A		新增70gf產品	09.06.03	邱明義
B		新增100gf產品	07.07.05	邱明義
A		DWG. REL.	02.22.05	邱明義

APPD:	邱明義
DRD:	邱明義
REV:	C
SCALE:	15:1
UNITS:	mm
DESIGN:	陳清梅

QTY:	
SCALE:	15:1
UNITS:	mm
DESIGN:	陳清梅
REV:	C
APPD:	邱明義

PART NAME:	TMG-53*-V
DWG NO:	R D 5 P 5 G - V
FINISH:	
See Table 1	
PART NO:	
REV:	
SCALE:	
UNITS:	
DESIGN:	
APPD:	

圖達實業股份有限公司
DIPTRONICS MANUFACTURING INC.



1. Style

This specification describes "TACTILE SWITCH", mainly used as signal switch of electric devices, with the general requirements of mechanical and electrical characteristic.

1.1 Operating Temperature Range : -25 °C ~ +70 °C

1.2 Storage Temperature Range : -30 °C ~ +80 °C

2. **Current Range:** 50mA, 12V DC

3. **Type of Actuation:** Tactile feedback

4. **Test Sequence:**

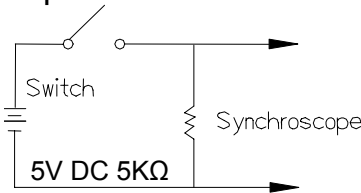
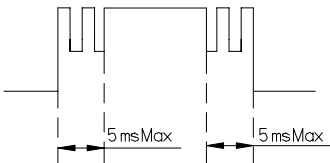
	ITEM	DESCRIPTION	TEST CONDITIONS	REQUIREMENTS
APPEARANCE	1	Visual Examination	By Visual Examination choke without any out pressure & testing	There shall be no defects that affect the serviceability of the product.
ELECTRIC PERFORMANCE	2	Contact Resistance	Applying a static load 1.5-2 times the operating force to the center of the stem, measurements shall be made with a 1 kHz small current contact resistance meter	100mΩ Max
	3	Insulation Resistance	Measurements shall be made following application of 500 V DC potential across terminals and cover for 1 minute ± 5 seconds	100MΩ min
	4	Dielectric Withstanding Voltage	250 V AC(50Hz or 60Hz) shall be applied across terminals and cover for 1 minute	There shall be no breakdown or flashover
	5	Capacitance	1 MHz ±10 kHz	5 pF max.
	6	Bounce	3 to 4 operations at a rate of 1 cycles per second 	5 m seconds max. 



MECHANICAL PERFORMANCE	7	Operating Force	Applied in the direction of operation 	OF	100±50g [0.98±.49N]	160±50g [1.568±.49N]	260±50g [2.548±.49N]
	8	Stroke	Placing the switch such that the direction of switch operation is vertical and then gradually increasing the load applied to the stem, the stroke distance for the stem to come to a stop shall be measured	0.25+0.1/-0.2mm			
	9	Stop Strength	Placing the switch such that the direction of switch operation is vertical, a static load of 3 kgf(29.4N) shall be applied in the direction of stem operation for a period of 15 seconds	1)As shown in item 4~7 2)Contact Resistance: 200mΩ Max 3)Insulation Resistance: 10MΩ min			
	10	Solder Heat Resistance	1.PCB is 1.6mm in thickness 2.SMT Type ~TMG(E)、TJG(E)-5 Series(4/4)	1)As shown in item 4、5 2)Contact Resistance: 200mΩ Max 3)Insulation Resistance: 10MΩ min			
	11	Vibration	Shall be vibrated in accordance with Method 201A of MIL-STD-202F 1.Swing distance:1.5mm 2.Frequency: 10-55-10Hz in 1-min/cycle. 3.Direction: 3 vertical directions including the directions of operation 4.Test time: 2 hours each direction	1)As shown in item 4~7 2)Contact Resistance: 200mΩ Max 3)Insulation Resistance: 10MΩ min			
MECHANICAL PERFORMANCE	12	Shock	Shall be shocked in accordance with Method 213B condition A of MIL-STD-202F 1.Acceleration; 50G 2.Action time:11±1m seconds 3.Testing Direction: 6 sides 4.Test Cycle: 3 times in each direction	Ditto			



DURABILITY	13	Operating Life	<p>Measurements shall be made following the test forth below:</p> <ol style="list-style-type: none"> 1. 5 mA, 5 VDC resistive load 2. Applying a static load the operating force to the center of the stem in the direction of operation Static Load = OF max 3. Cycle of Operation: 1,000,000 cycles min. For 100、160gf 200,000 cycles min. For 260gf 	<ol style="list-style-type: none"> 1. As shown in item 4、5 2. Operating force: ±50% of initial force . 3. Contact Resistance: 10Ω Max 4. Insulation Resistance: 10MΩ min 5. Bounce: 10 m seconds Max 	
	WEATHER-PROOF	14	Resistance Low Temperature	<p>Following the test set forth below the sample shall be left in normal temperature and humidity conditions for 1 hour before the measurements are made:</p> <ol style="list-style-type: none"> 1. Temperature: -25±3℃ 2. Time: 96 hours 	<ol style="list-style-type: none"> 1) As shown in item 4~7 2) Contact Resistance: 200mΩ Max 3) Insulation Resistance: 10MΩ min
		15	Resistance High Temperature	<p>Following the test set forth below the sample shall be left in normal temperature and humidity conditions for 1 hour before the measurements are made:</p> <ol style="list-style-type: none"> 1. Temperature: 80±2℃ 2. Time: 96 hours 	Ditto
16		Humidity Resistance	<p>Following the test set forth below the sample shall be left in normal temperature and humidity conditions for 1 hour before the measurements are made:</p> <ol style="list-style-type: none"> 1) Temperature: 40±2℃ 2) Relative Humidity: 90~95% 3) Time: 96 hours 	Ditto	

5. SOLDERING CONDITIONS:

■ Condition for Soldering TMG(E) 、 TJG(E)-5 Series

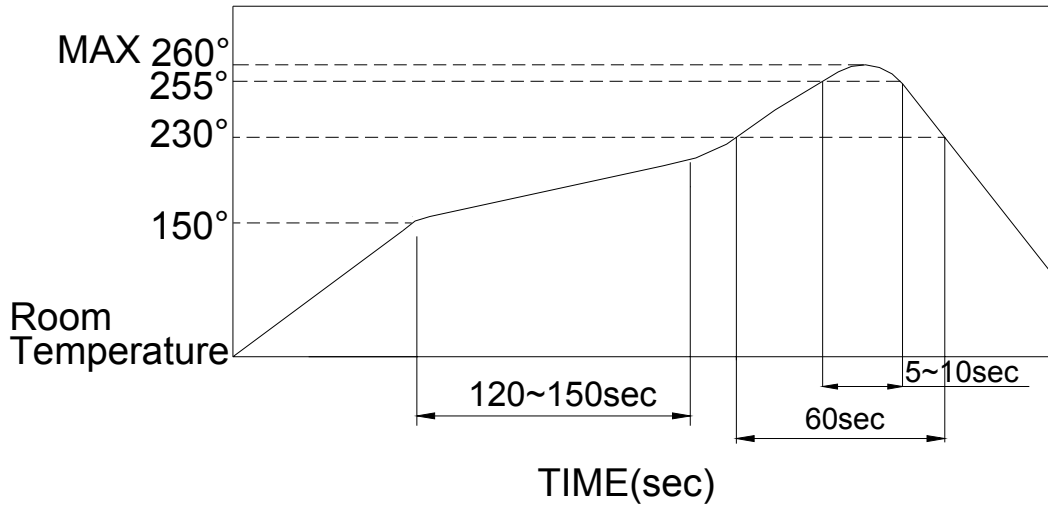

- The condition mentioned above is the temperature on the Cu foil of the PCB surface. There are cases where board's temperature greatly differs from switch's surface be used not to allow switch's surface temperature to exceed 260°C.

■ Manual Soldering

Soldering Temperature	Max.350°C
Continuous Soldering Time	Max. 5 seconds

■ Precautions in Handling

- 1.Care should be exercised so that flux from the upper part of the printed circuit board does not adhere to the switch.
- 2.Except for washable type do not wash the switch body.
- 3.Press direction & illustrated drawing:

