

PARAMETER		UNITS
TURNS RATIO	(10-7) : (9-6) 1 : 1 ±1% Tie7-9, (10-6) : (1-5) 2.2 : 1 ±1%	
Inductance ¹	3.0 ±6%	mH
Leakage Inductance ²	10.0 Max.	μH
DCR Pins 10 - 7	1.26 Max	Ω
DCR Pins 9 - 6	1.26 Max	Ω
DCR Pins 1 - 5	0.66 Max	Ω
THD ³	-70	dB
Longitudinal Balance at 20 kHz to 250 kHz	55 Min.	dB
Interwinding Capacitance	100 Max	pF
Isolation 1 to 10, (tie 7-9)	2050	VAC

ADSL Line Interface Transformer

Designed to meet supplementary insulation requirements of IEC950 for working voltage of 250 Vrms

Schematic Diagram

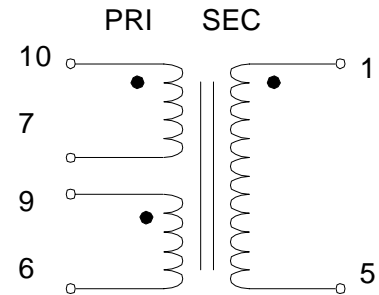

1. Tested @ 10 kHz and 1.0 VAC (Pins 10-6) With 7-9 shorted, and 100mADC.
 2. Tested @ 100 kHz and 100 mVAC (Pins 10-6) With 7-9, 1-5 shorted.
 3. Tested @ 40kHz - 1.65VrmsVAC across Pri, 28 ohm load, 135 ohm input, tie (7-9)
- Operating temperature range -40°C to + 85°C

Physical Dimensions
inches (mm)

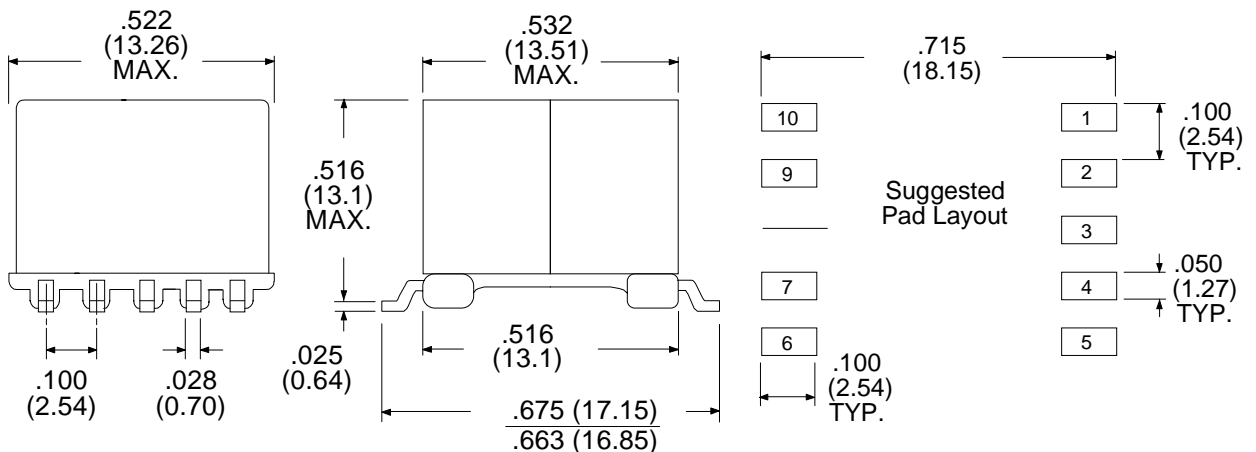

Rhombus P/N: **T-1274G**

Cust. P/N:

Name:

Date: **9/13/99**

Sheet: 1 of 1