

CMOS area image sensors



S10830

S10834

CMOS area image sensors for X-ray imaging

S10830 is CMOS area image sensor suitable for intra-oral X-ray imaging in dental diagnosis. S10830 has 1.5 megapixels (1000 × 1500) with a pixel size of 20 × 20 μm. FOP (fiber optic plate) is used as an input window, making S10830 high image-quality and long-term X-ray life. S10834 is an easy-to-use X-ray imaging module using S10830 with a cable. S10830 has 14-bit ADC on chip and LVDS digital output signal. These features are to contribute cost reduction in a user's system. S10831 and S10835 (1300 × 1700 pixels) are also available.

Features

- Pixel size: 20 × 20 μm
- 1000 (H) × 1500 (V) pixel format
- Frame rate: 0.9 frames/s (MCLK=20 MHz)
- High resolution: 20 Lp/mm typ.
- 14-bit ADC (virtual dynamic range: 58 dB)
- Image data acquisition by Vdd, Vss, MCLK and MST only
- Global shutter operation
- Photodiode placed outside the active area to monitor x-ray irradiation

Applications

- Intra-oral X-ray imaging dental diagnosis
- General X-ray imaging
- Non-destructive inspection

These products are components for incorporation into medical and industrial device.

Structure

Parameter	Value	Unit
Pixel size	20 × 20	μm
Pixel pitch	20	μm
Number of effective pixels	1000 (H) × 1500 (V)	pixels
Number of light-shielded pixels	Upper part: 766, 768, 770 Lower part: 1000 × 3	pixels
Image size	20 (H) × 30 (V)	mm

Absolute maximum ratings

Parameter	Symbol	Value	Unit
Power supply	Vdd	-0.5 to +6	V
Input voltage	Vi	-0.5 to "Vdd + 0.5" (6 max.)	V
Consumption current	Idd	400	mA
Operating temperature	Topr	0 to +50	°C
Storage temperature	Tstg	-20 to +70	°C
Total dose irradiation	D	50	Gy

Recommended operating conditions

Parameter	Symbol	Min.	Typ.	Max.	Unit
Power supply	Vdd	4.75	5.0	5.5	V
Digital input voltage*1	High	Vsigi(H)	2.4	3.3	Vdd + 0.25
	Low	Vsigi(L)	0	-	

*1: Vsigi(H) is a "High" period voltage of MST and MCLK, Vsigi(L) is a "Low" period voltage of MST and MCLK.

Electrical characteristics (Ta=25 °C, Vdd=5 V)

Parameter	Symbol	Min.	Typ.	Max.	Unit
Master clock pulse frequency	f(MCLK)	1 M	20 M	40 M	Hz
Digital output format	-	LVDS differential output			-
Digital output frequency	Image sensor*2	-	f(MCLK)	-	Hz
	Trigger photodiode*3	-	f(MCLK)/56	-	
Digital output voltage*4	V(DOmag)	-	350	-	mV
Digital output rise time*4 *5	tr(DO)	-	2	5	ns
Digital output fall time*4 *5	tf(DO)	-	2	5	ns
Video data rate	Image sensor*6	VR	f(MCLK)/14	-	Hz
	Trigger photodiode	VR2	f(MCLK)/7168	-	Hz
Start pulse interval*7	T(ST-I)	22.7 M	-	-	MCLK
Integration time	Image sensor*8	-	PW(MST) + 394/f(MCLK)		s
	Trigger photodiode*9	-	6608/f(MCLK)		s
Consumption current	Image sensor*10	P1	55	110	mA
	Trigger photodiode*11	P2	25	50	mA

*2: Refer to "Timing chart", Image data readout.

*3: Refer to "Timing chart", Trigger photodiode data readout.

*4: The output voltage difference between LVDS differential terminals with 100 Ω termination

*5: The time in output from 10% to 90% or from 90% to 10% with 2 m long cable

*6: It takes 14 master clock pulse cycles to read out 1 pixel

*7: It takes 22.7 M master clock pulse cycles to read out 1 frame of an image. The readout of the next frame must be started after finishing the readout of previous frame.

*8: Refer to "Timing chart", PW(MST) is "Low" pulse width of MST (master start pulse).

e.g.) When the PW(MST) is 10 ms and f(MCLK) is 20 MHz:

$$\text{Integration time} = 10 \text{ ms} + 394/20 \text{ M} = 10.0197 \text{ ms}$$

*9: Refer to "Timing chart", The trigger photodiode is output every 7168 MCLK cycles. The integration time is 6608 MCLK cycles, and 560 MCLK cycles are used for the reset period of trigger photodiode.

e.g.) When the f(MCLK) is 20 MHz:

$$\text{Integration time} = 6608/20 \text{ M} = 330.4 \text{ } \mu\text{s}$$

*10: The consumption current of image sensor chip only. f(MCLK)=20 MHz

*11: The consumption current of image sensor chip only. Without 100 Ω termination (see "Output format" in P.7). f(MCLK)=20 MHz

Resolution (S10834)

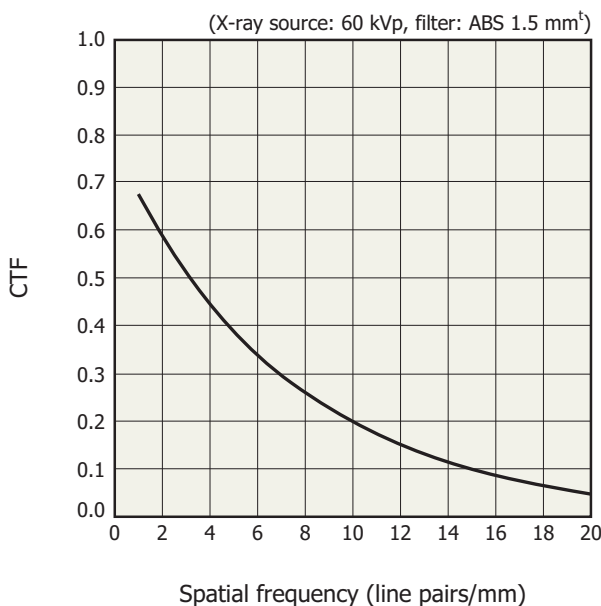

Response (S10834)

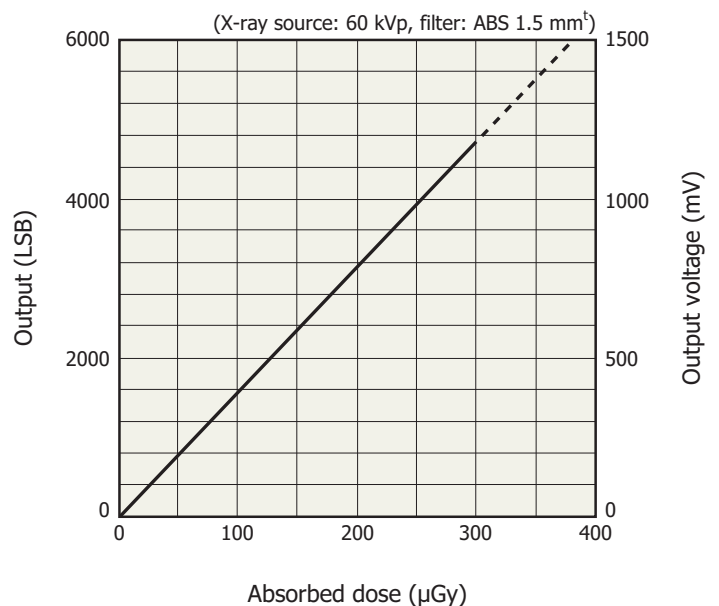

KMPDB0358EA

KMPDB0359EA

Electrical and optical characteristics (image sensor, Ta=25 °C, Vdd=5 V)

Parameter		Symbol	Min.	Typ.	Max.	Unit
Dark output voltage (effective pixel)*12		Vdark	-	50	120	mV/s
		Ddark	-	200	490	LSB/s
Saturation output voltage		Vsat	0.8	1.2	-	V
		Dsat	3280	4900	-	LSB
Random noise*13		VRN	-	1500	4500	μV rms
		DRN	-	6.2	18	LSB rms
Dynamic range*14		DR	45	58	-	dB
Sensitivity*15		VRES	2.3	3.4	4.5	mV/μGy
		DRES	9.4	14	18	LSB/μGy
Saturation dose*15		Lsat	180	350	530	μGy
Photo response non-uniformity*12 *16		PRNU	-	-	±30	%
Blemish	Point defect*17	White spot	-	-	20	-
		Black spot	-	-	20	
	Cluster defect*18	-	-	3		
	Big cluster defect*19	-	-	0		
Defect line*20		DL	-	-	15	lines
X-ray resolution		Reso	15	20	-	Lp/mm

*12: Average value. Excluding defect pixels.

*13: Integration time = 1 s

*14: Dynamic range = $20 \times \log \left(\frac{\text{Saturation output voltage}}{\text{Random noise}} \right)$

*15: 60 kV tube voltage, no Al plate at X-ray emission

*16: PRNU (%) = $\Delta V / V \times 100$

V: average of pixel outputs, ΔV: difference between V and min. or max. output

*17: White spot > 1.2 V/s (4900 LSB/s) at effective pixel: 10 times of the maximum of dark output

Black spot > 50% reduction in response relative to adjacent pixels, measured at half of the saturation output

*18: Continuous 2 to 9 point defects

*19: Continuous 10 or more point defects. (except a defect line)

*20: A defect line consists of 10 or more point defects in 1 pixel width.

Electrical and optical characteristics (trigger photodiode, Ta=25 °C, Vdd=5 V)

Parameter		Symbol	Min.	Typ.	Max.	Unit
Saturation voltage		Vsat	-	2.2	2.9	V
		Dsat	-	450	590	LSB
Random noise		VRN	-	10	-	mV rms
		DRN	-	2	-	LSB rms
Sensitivity*21		VRES	-	6.8×10^2	-	mV/μGy
		DRES	-	200	-	LSB/μGy
Offset of A/D converter		-	-	430	-	LSB

*21: Integration time=330 μs, f(MCLK)=20 MHz

Electrical and optical characteristics (A/D converter, Ta=25 °C, Vdd=5 V)

Parameter	Symbol	Image sensor	Trigger photodiode	Unit
Resolution	RESO	14	10	bit
Connection time	tCON	$1/14 \times f(\text{MCLK})$	$1/7168 \times f(\text{MCLK})$	s
Conversion voltage range	-	0 to 4	0 to Vdd	V

Block diagram

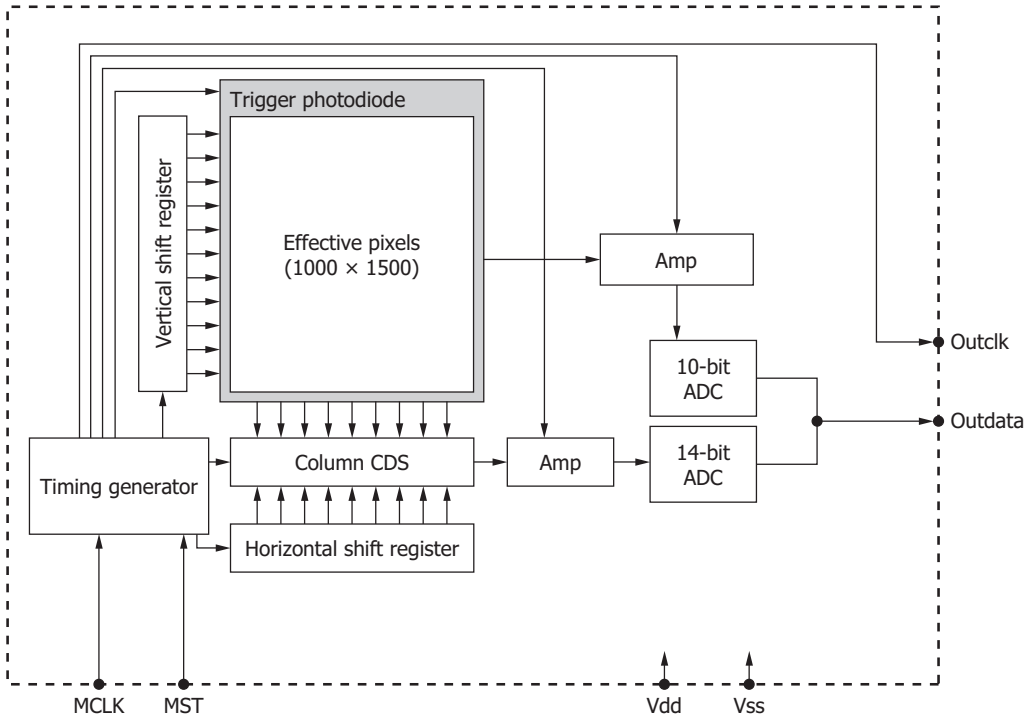

KMPDC0356EB

Timing chart

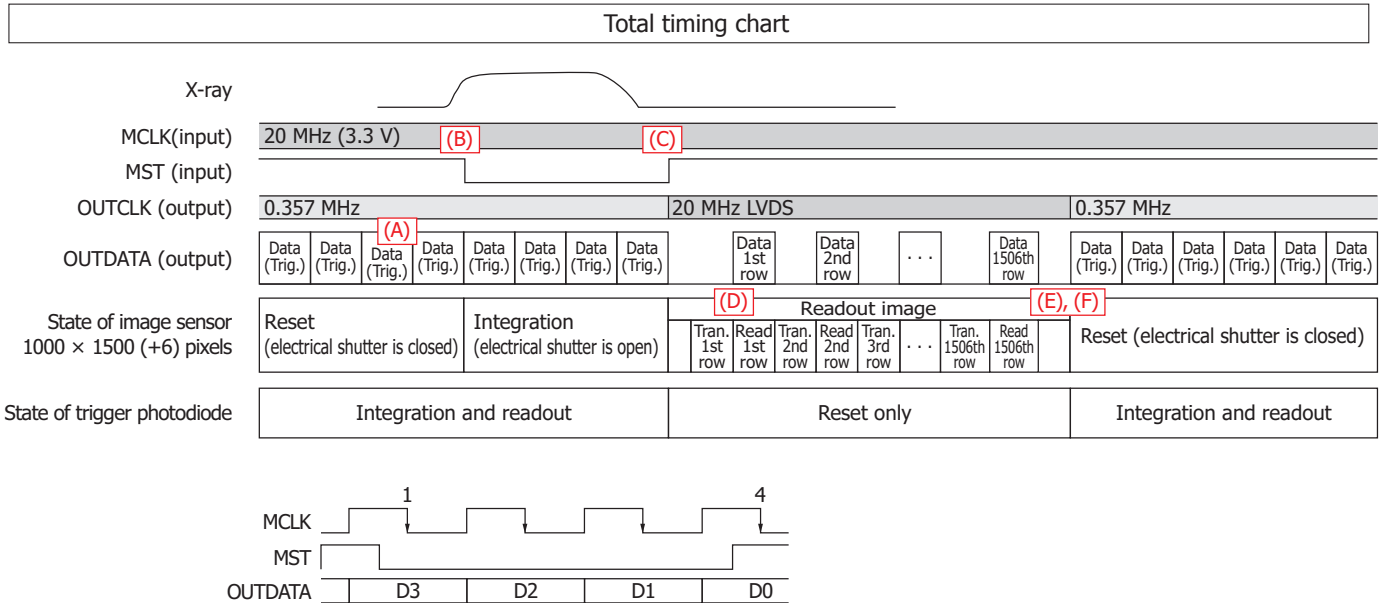

- (A) Continuously checking some X-ray radiation with monitoring the data of trigger photodiode by an external circuit.
- (B) The MST should be set at low and integration of each pixel is to start when X-ray input is detected.
The Integration time is almost same as the low width of the MST. It can be controlled by an external circuit (software, firmware, etc.).
- (C) Just after the MST is set at high, the integration is to finish and readout starts.
- (D) Each readout row has a header part, which consists of 28 high levels of the OUTDATA.
- (E), (F) After completion readout, the OUTCLK and the OUTDATA automatically move to state of trigger photodiode.

KMPDC0357EB

(A) Trigger photodiode data readout

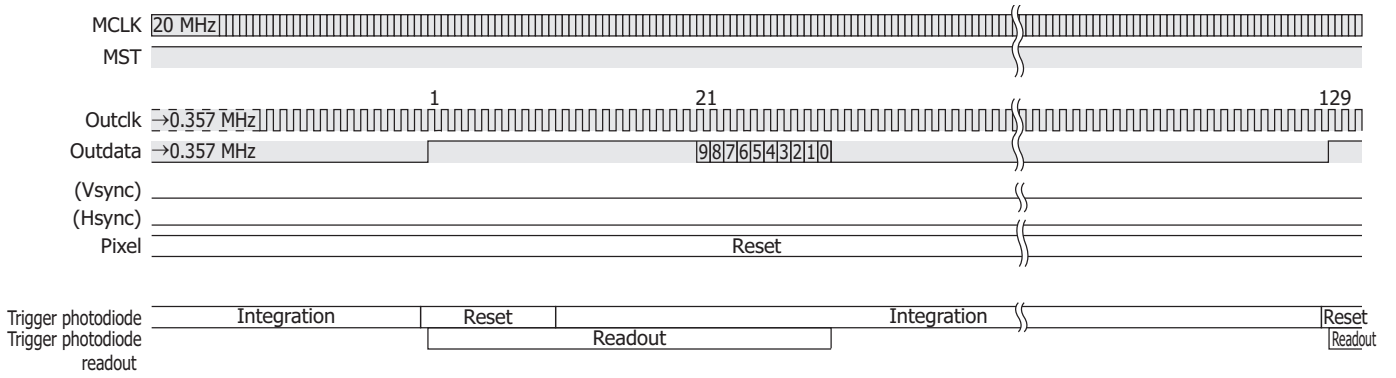

(B) Image data integration start

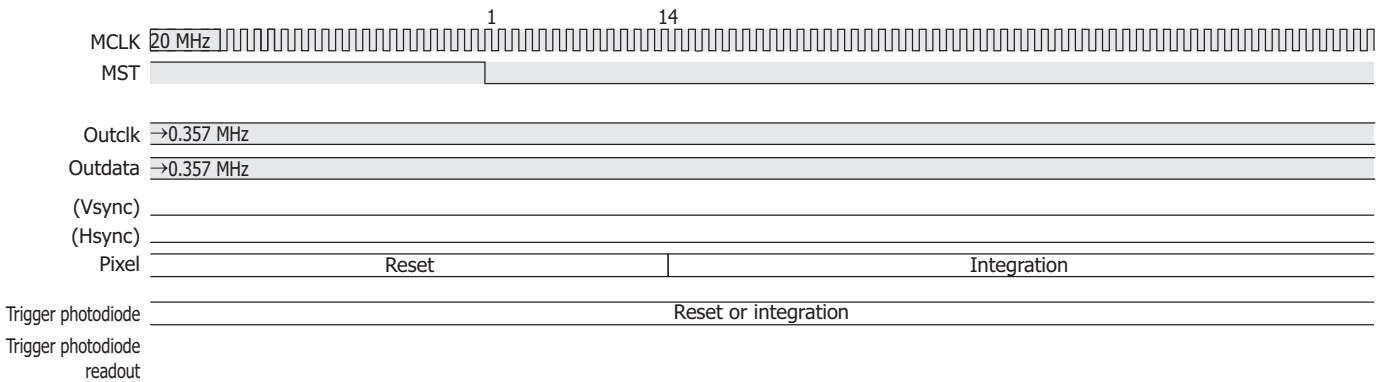

(C) Image data readout start

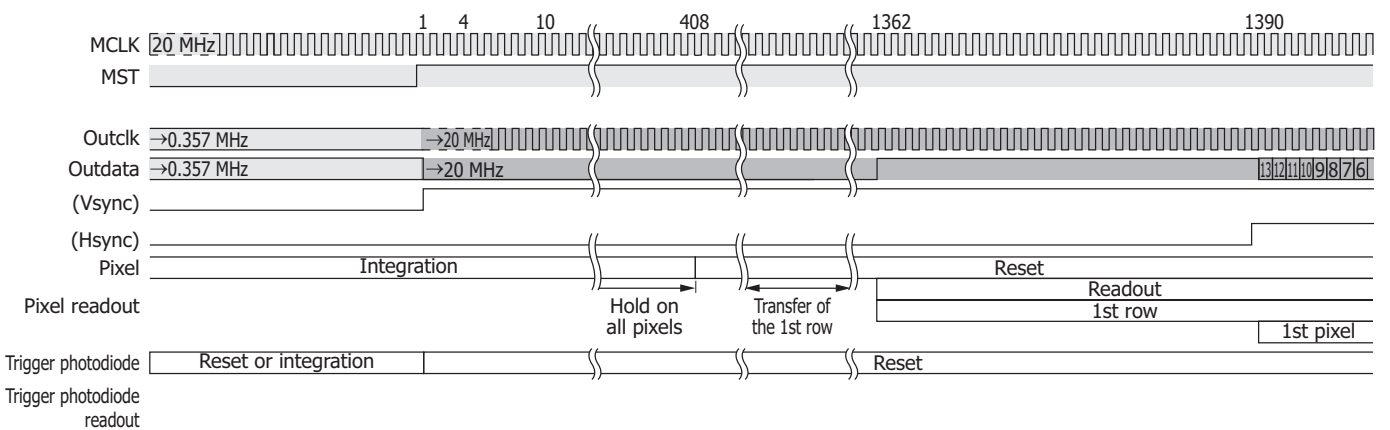

Note: All on-chip timing circuits are reset at rise of MST, and the operations of trigger photodiode readout are stopped at this time.

(D) Image data readout

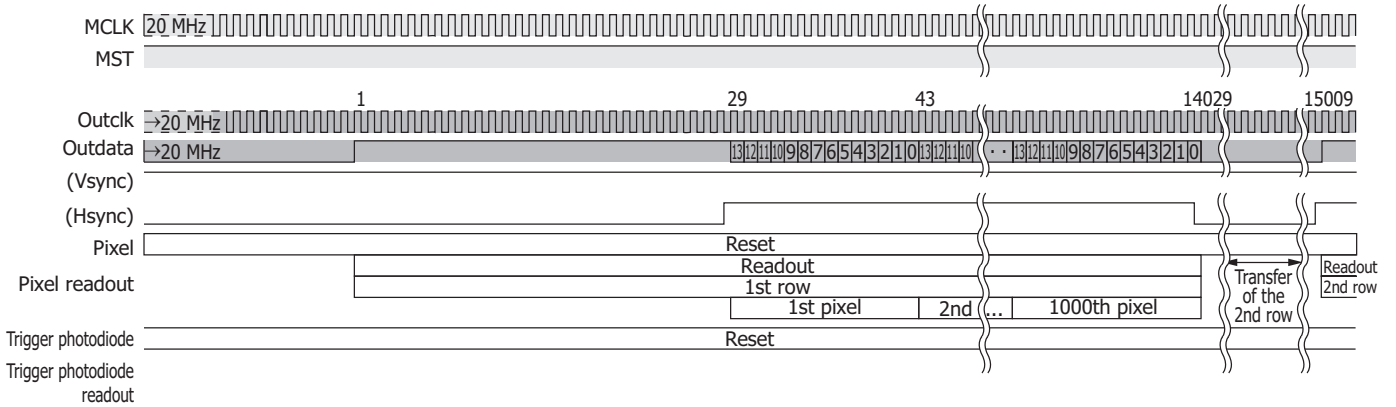

KMPDC0361EB

(E) Image readout end

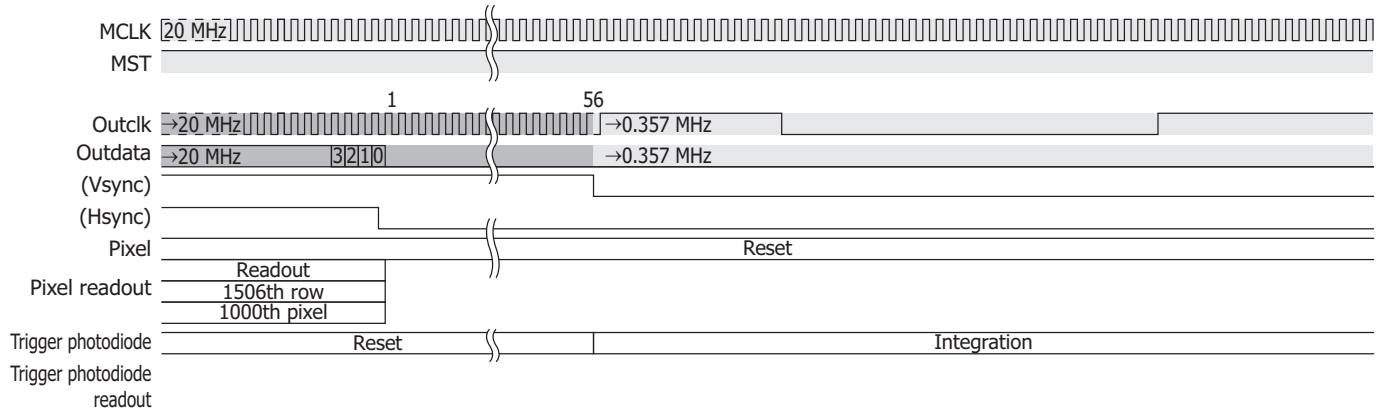

KMPDC0362EB

(F) Image readout end (trigger photodiode)

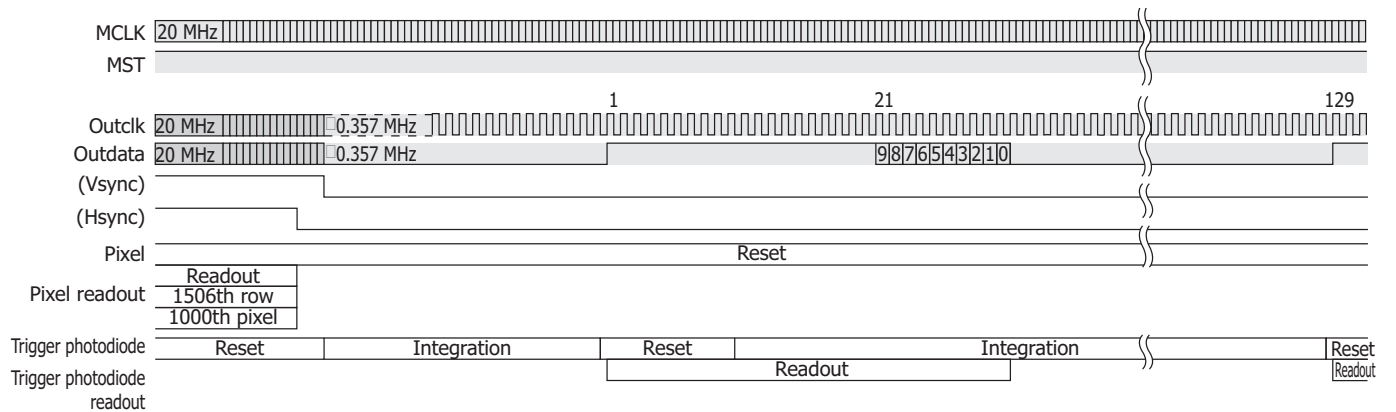

Note: Just after image data is finished, the 1st readout of trigger photodiode is not valid, because integration time is shorter than others.

KMPDC0363EB

■ Output format (Ta=25 °C, Vdd=5 V)

■ With 100 Ω termination (LVDS output mode)

Parameter	Symbol	Min.	Typ.	Max.	Unit
Differential output swing	Vod	247	-	454	mV
Offset voltage	Vos	-	1.2	-	V
Current (100 Ω termination)	I100	-	3.5	-	mA

■ Without 100 Ω termination (CMOS output mode)

Parameter	Symbol	Min.	Typ.	Max.	Unit
Output voltage	High level	Vod	-	2.4	V
	Low level	Vos	-	0	V

■ Dimensional outline (unit: mm)

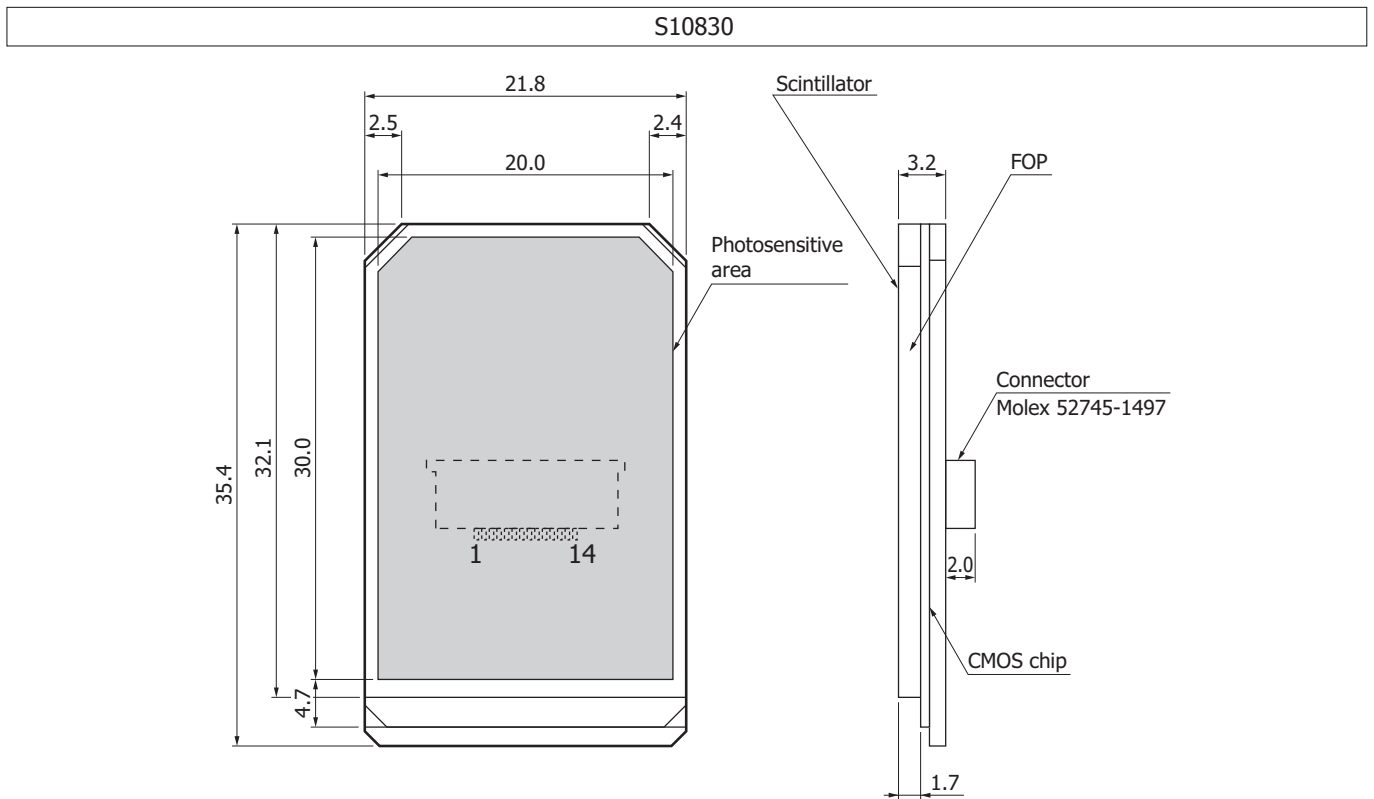

KMPDA0266EC

■ Pin connections

Pin no.	Description	I/O	Function
1	Vdd	I	Power supply voltage (5 V)
2	Vss	I	Ground
3	Outdata a	O	Video output signal (LVDS, positive)
4	Reserve	-	
5	Outdata b	O	Video output signal (LVDS, negative)
6	Reserve	-	
7	Outclk a	O	Trigger signal (LVDS, positive)
8	Reserve	-	
9	Outclk b	O	Trigger signal (LVDS, negative)
10	Reserve	-	
11	MST	I	Master start signal
12	Reserve	-	
13	MCLK	I	Master clock signal
14	Reserve	-	

S10834

■ Entire view

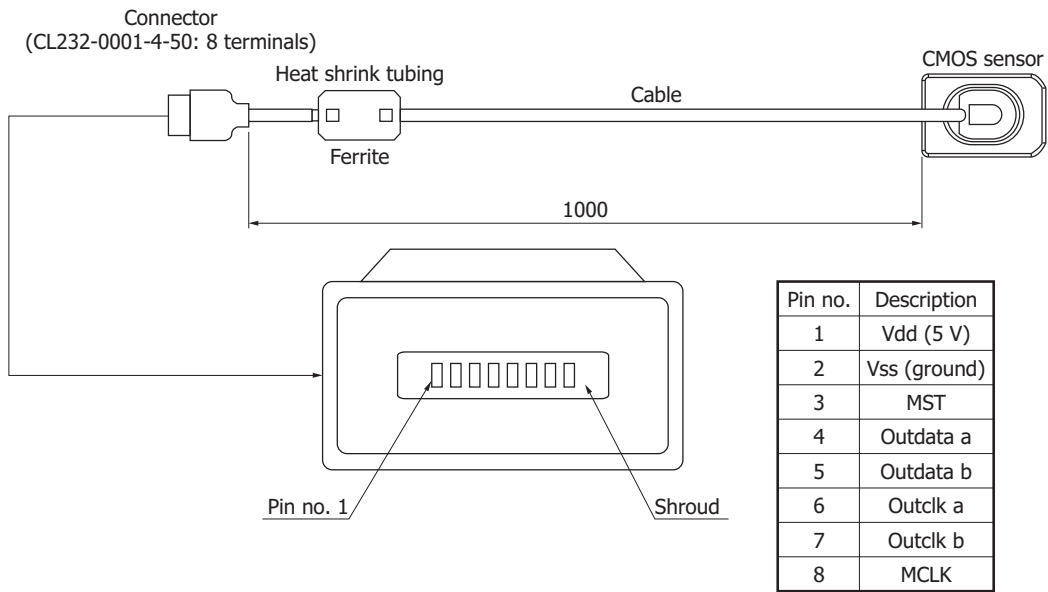

KMPDA0252EB

■ CMOS sensor

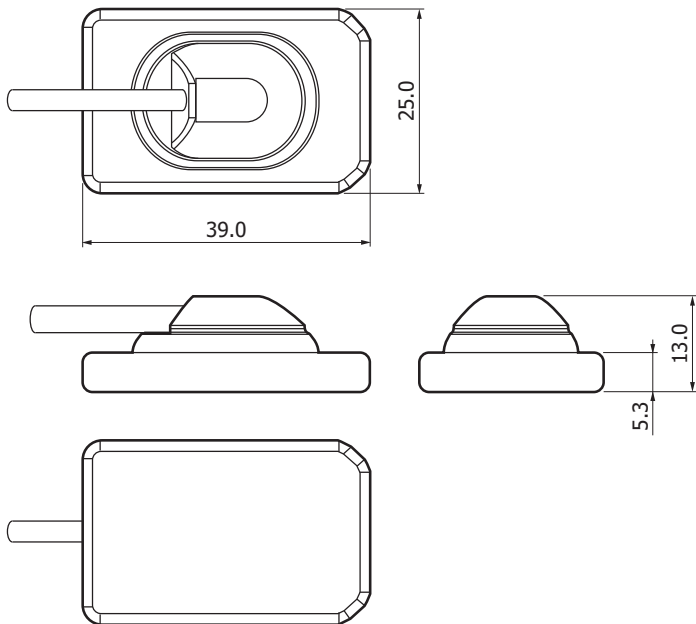

KMPDA0253EB

Photosensitive area

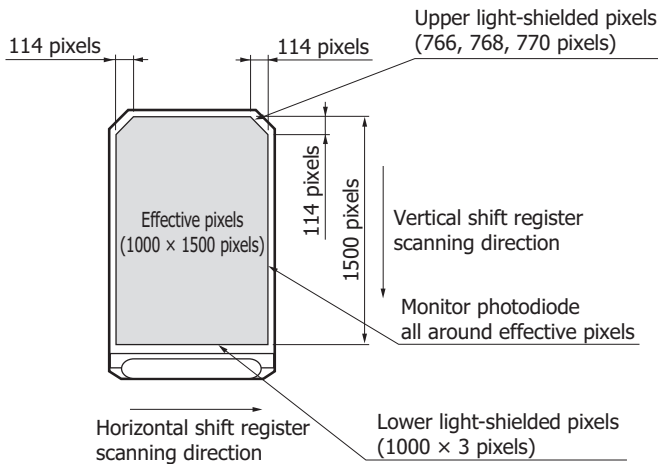

KMPDC0448EA

Notice

- This product is warranted for a period of 12 months after the date of the shipment. The warranty is limited to replacement or repair of any defective product due to defects in workmanship or materials used in manufacture. The warranty does not cover loss or damage caused by natural disaster, misuse (including modifications and any use not complying with the environment, application, usage and storage conditions described in this datasheet), or total radiation dose over 50 Gy (incident X-ray energy: 70 kVp) even within the warranty period.

Information described in this material is current as of April, 2014.

Product specifications are subject to change without prior notice due to improvements or other reasons. This document has been carefully prepared and the information contained is believed to be accurate. In rare cases, however, there may be inaccuracies such as text errors. Before using these products, always contact us for the delivery specification sheet to check the latest specifications.

The product warranty is valid for one year after delivery and is limited to product repair or replacement for defects discovered and reported to us within that one year period. However, even if within the warranty period we accept absolutely no liability for any loss caused by natural disasters or improper product use.

Copying or reprinting the contents described in this material in whole or in part is prohibited without our prior permission.

HAMAMATSU

www.hamamatsu.com

HAMAMATSU PHOTONICS K.K., Solid State Division

1126-1 Ichino-cho, Higashi-ku, Hamamatsu City, 435-8558 Japan, Telephone: (81) 53-434-3311, Fax: (81) 53-434-5184

U.S.A.: Hamamatsu Corporation: 360 Foothill Road, Bridgewater, N.J. 08807, U.S.A., Telephone: (1) 908-231-0960, Fax: (1) 908-231-1218

Germany: Hamamatsu Photonics Deutschland GmbH: Arzbergerstr. 10, D-82211 Herrsching am Ammersee, Germany, Telephone: (49) 8152-375-0, Fax: (49) 8152-265-8

France: Hamamatsu Photonics France S.A.R.L.: 19, Rue du Saule Trapu, Parc du Moulin de Massy, 91882 Massy Cedex, France, Telephone: 33-(1) 69 53 71 00, Fax: 33-(1) 69 53 71 10

United Kingdom: Hamamatsu Photonics UK Limited: 2 Howard Court, 10 Tewin Road, Welwyn Garden City, Hertfordshire AL7 1BW, United Kingdom, Telephone: (44) 1707-294888, Fax: (44) 1707-325777

North Europe: Hamamatsu Photonics Norden AB: Torshamnsgatan 35 16440 Kista, Sweden, Telephone: (46) 8-509-031-00, Fax: (46) 8-509-031-01

Italy: Hamamatsu Photonics Italia S.r.l.: Strada della Moia, 1 int. 6, 20020 Arese (Milano), Italy, Telephone: (39) 02-93581733, Fax: (39) 02-93581741

China: Hamamatsu Photonics (China) Co., Ltd.: B1201, Jiaming Center, No.27 Dongsanhuan Beilu, Chaoyang District, Beijing 100020, China, Telephone: (86) 10-6586-6006, Fax: (86) 10-6586-2866