

32-bit Microcontroller

CMOS

FR60 MB91460S Series

MB91F467SA

■ DESCRIPTION

MB91460S series is a line of general-purpose 32-bit RISC microcontrollers designed for embedded control applications which require high-speed real-time processing, such as consumer devices and on-board vehicle systems. This series uses the FR60 CPU, which is compatible with the FR family* of CPUs.

This series contains the LIN-USART, CAN and APIX[®] controllers.

* : FR, the abbreviation of FUJITSU RISC controller, is a line of products of FUJITSU Microelectronics Limited.

■ FEATURES

1. FR60 CPU core

- 32-bit RISC, load/store architecture, five-stage pipeline
- 16-bit fixed-length instructions (basic instructions)
- Instruction execution speed: 1 instruction per cycle
- Instructions including memory-to-memory transfer, bit manipulation, and barrel shift instructions: Instructions suitable for embedded applications
- Function entry/exit instructions and register data multi-load store instructions : Instructions supporting C language
- Register interlock function: Facilitating assembly-language coding
- Built-in multiplier with instruction-level support
 - Signed 32-bit multiplication: 5 cycles
 - Signed 16-bit multiplication: 3 cycles
- Interrupts (save PC/PS) : 6 cycles (16 priority levels)
- Harvard architecture enabling program access and data access to be performed simultaneously
- Instructions compatible with the FR family

For the information for microcontroller supports, see the following web site.

This web site includes the "**Customer Design Review Supplement**" which provides the latest cautions on system development and the minimal requirements to be checked to prevent problems before the system development.

<http://edevic.fujitsu.com/micom/en-support/>

2. Internal peripheral resources

- General-purpose ports : Maximum 133 ports
- DMAC (DMA Controller)
 - Maximum of 5 channels able to operate simultaneously.
 - 2 transfer sources (internal peripheral/software)
 - Activation source can be selected using software.
 - Addressing mode specifies full 32-bit addresses (increment/decrement/fixed)
 - Transfer mode (demand transfer/burst transfer/step transfer/block transfer)
 - Transfer data size selectable from 8/16/32-bit
 - Multi-byte transfer enabled (by software)
 - DMAC descriptor in I/O areas (200_H to 240_H, 1000_H to 1024_H)
- A/D converter (successive approximation type)
 - 10-bit resolution: 16 channels
 - Conversion time: minimum 1 μ s
- External interrupt inputs : 16 channels
 - Shares the CAN RX pin and I²C SDA pin
- Bit search module (for REALOS)
 - Function to search from the MSB (most significant bit) for the position of the first “0”, “1”, or changed bit in a word
- LIN-USART (full duplex double buffer): 6 channels
 - Clock synchronous/asynchronous selectable
 - Sync-break detection
 - Internal dedicated baud rate generator
- I²C bus interface (supports 400 kbps): 3 channels
 - Master/slave transmission and reception
 - Arbitration function, clock synchronization function
- CAN controller (C-CAN): 2 channels
 - Maximum transfer speed: 1 Mbps
 - 32 transmission/reception message buffers
- APIX[®] controller
 - APIX[®] link (105Mbit / 6Mbit): 1 channel
 - Automotive Interconnect links (5Mbit / 6Mbit): 2 links
- Sound generator : 1 channel
 - Tone frequency : PWM frequency divide-by-two (reload value + 1)
- Alarm comparator : 1 channel
 - Monitor external voltage
 - Generate an interrupt in case of voltage lower/higher than the defined thresholds (reference voltage)
- 16-bit PPG timer : 16 channels
- 16-bit PFM timer : 1 channel
- 16-bit reload timer: 8 channels
- 16-bit free-run timer: 8 channels (1 channel each for ICU and OCU)
- Input capture: 8 channels (operates in conjunction with the free-run timer)
- Output compare: 4 channels (operates in conjunction with the free-run timer)
- Up/Down counter: 4 channels (4×8-bit or 2×16 bit)
- Watchdog timer
- Real-time clock
- Low-power consumption modes : Sleep/stop mode function
- Low voltage detection circuit
- Clock monitor

- Clock supervisor
Monitors the sub-clock (32 kHz) and the main clock (4 MHz) , and switches to a recovery clock (CR oscillator, etc.) when the oscillations stop.
- Clock modulator *
- Sub-clock calibration
Corrects the real-time clock timer when operating with the 32 kHz or CR oscillator
- Main oscillator stabilization timer
Generates an interrupt in sub-clock mode after the stabilization wait time has elapsed on the 23-bit stabilization wait time counter
- Sub-oscillator stabilization timer
Generates an interrupt in main clock mode after the stabilization wait time has elapsed on the 15-bit stabilization wait time counter

3. Package and technology

- Package : LQFP-176
- CMOS 0.18 μm technology
- Power supply range 3 V to 5 V (1.8 V internal logic provided by a step-down voltage converter)
- Operating temperature range: between -40°C and $+105^{\circ}\text{C}$

* : The clock modulator is currently being evaluated and should not be used for other purpose than testing.

Note APIX® is a registered mark of INOVA Semiconductors GmbH

MB91460S Series

■ PRODUCT LINEUP

Feature	MB91V460A	MB91F467SA
Max. core frequency (CLKB)	80MHz	100MHz
Max. resource frequency (CLKP)	40MHz	50MHz
Max. external bus freq. (CLKT)	40MHz	50MHz
Max. CAN frequency (CLKCAN)	20MHz	40MHz
Max. FlexRay frequency (SCLK)	-	-
Technology	0.35μm	0.18μm
Watchdog	yes	yes
Watchdog (RC osc. based)	yes (disengageable)	yes
Bit Search	yes	yes
Reset input (INITX)	yes	yes
Hardware Standby input (HSTX)	yes	no
Clock Modulator	yes	yes
Clock Monitor	yes	yes
Low Power Mode	yes	yes
DMA	5 ch	5 ch
MAC (μDSP)	no	no
MMU/MPU	MPU (16 ch) ¹⁾	MPU (8 ch) ¹⁾
Flash	Emulation SRAM 32bit read data	1088 KByte
Satellite Flash	-	no
Flash Protection	-	yes
D-RAM	64 KByte	32 KByte
ID-RAM	64 KByte	32 KByte
Flash-Cache (Instruction cache)	16 KByte	8 KByte
Boot-ROM / BI-ROM	4 KByte fixed	4 KByte
RTC	1 ch	1 ch
Free Running Timer	8 ch	8 ch
ICU	8 ch	8 ch
OCU	8 ch	4 ch
Reload Timer	8 ch	8 ch
PPG 16-bit	16 ch	16 ch
PFM 16-bit	1 ch	1 ch
Sound Generator	1 ch	1 ch
Up/Down Counter (8/16-bit)	4 ch (8-bit) / 2 ch (16-bit)	4 ch (8-bit) / 2 ch (16-bit)

(Continued)

(Continued)

Feature	MB91V460A	MB91F467SA
C_CAN	6 ch (128msg)	2 ch (32msg)
LIN-USART	4 ch + 4 ch FIFO + 8 ch	2 ch + 4 ch FIFO
I ² C (400k)	4 ch	3 ch
APIX®	-	2ch (1ch physical)
FR external bus	yes (32bit addr, 32bit data)	yes (24bit addr, 16bit data)
External Interrupts	16 ch	16 ch
NMI Interrupts	1 ch	1 ch
SMC	6 ch	-
LCD controller (40x4)	1 ch	-
ADC (10 bit)	32 ch	16 ch
Alarm Comparator	2 ch	1 ch
Supply Supervisor	yes	yes
Clock Supervisor	yes	yes
Main clock oscillator	4MHz	4MHz
Sub clock oscillator	32kHz	32kHz
RC Oscillator	100kHz	100kHz / 2MHz
PLL	x 20	x 25
DSU4	yes	-
EDSU	yes (32 BP) *1	yes (16 BP) *1
Supply Voltage	3V / 5V	3V / 5V
Regulator	yes	yes
Power Consumption	n.a.	< 1 W
Temperature Range (Ta)	0..70 C	-40..105 C
Package	BGA660	LQFP176
Power on to PLL run	< 20 ms	< 20 ms
Flash Download Time	n.a.	< 30 sec (2M)

*1 : MPU channels use EDSU breakpoint registers (shared operation between MPU and EDSU).

MB91460S Series

PIN ASSIGNMENT

1. MB91F467SA

(TOP VIEW)

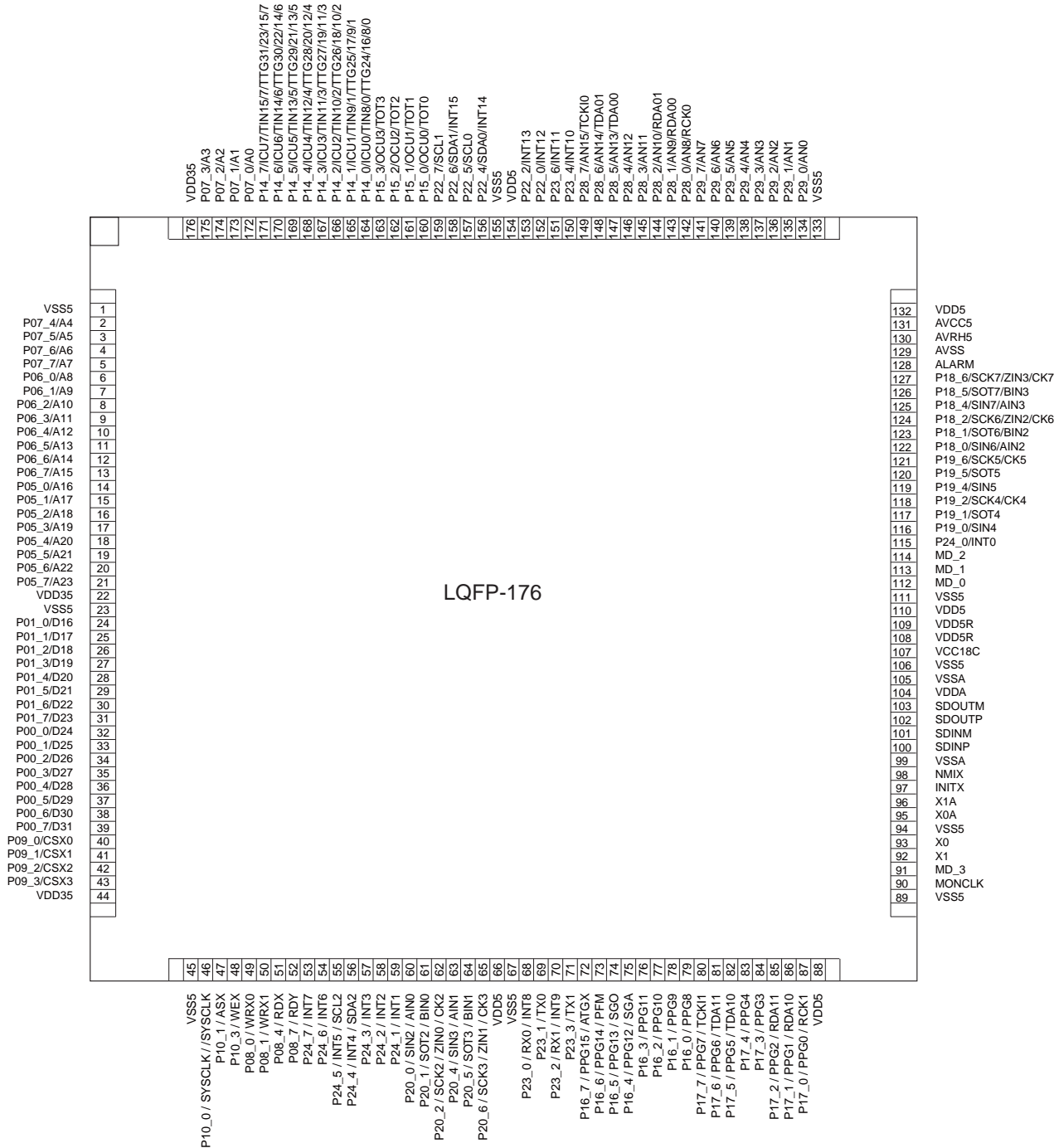

LQFP-176

(FPT-176P-M07)

■ PIN DESCRIPTION

1. MB91F467SA

Pin no.	Pin name	I/O	I/O circuit type*	Function
2 to 5	P07_4 to P07_7	I/O	A	General-purpose input/output ports
	A4 to A7			Signal pins of external address bus (bit4 to bit7)
6 to 13	P06_0 to P06_7	I/O	A	General-purpose input/output ports
	A8 to A15			Signal pins of external address bus (bit8 to bit15)
14 to 21	P05_0 to P05_7	I/O	A	General-purpose input/output ports
	A16 to A23			Signal pins of external address bus (bit16 to bit23)
24 to 31	P01_0 to P01_7	I/O	A	General-purpose input/output ports
	D16 to D23			Signal pins of external data bus (bit16 to bit23)
32 to 39	P00_0 to P00_7	I/O	A	General-purpose input/output ports
	D24 to D31			Signal pins of external data bus (bit24 to bit31)
40 to 43	P09_0 to P09_3	I/O	A	General-purpose input/output ports
	CSX0 to CSX3			Chip select output pins
46	P10_0	I/O	A	General-purpose input/output port
	SYSCLK			External bus clock output pin
47	P10_1	I/O	A	General-purpose input/output port
	ASX			Address strobe output pin
48	P10_3	I/O	A	General-purpose input/output port
	WEX			Write enable output pin
49, 50	P08_0, P08_1	I/O	A	General-purpose input/output port
	WRX0, WRX1			External write strobe output pin
51	P08_4	I/O	A	General-purpose input/output port
	RDX			External read strobe output pin
52	P08_7	I/O	A	General-purpose input/output port
	RDY			External ready input pin
53	P24_7	I/O	A	General-purpose input/output port
	INT7			External interrupt input pin
54	P24_6	I/O	A	General-purpose input/output port
	INT6			External interrupt input pin
55	P24_5	I/O	C	General-purpose input/output port
	INT5			External interrupt input pin
	SCL2			I ² C bus clock input/output pin

(Continued)

MB91460S Series

Pin no.	Pin name	I/O	I/O circuit type*	Function
56	P24_4	I/O	C	General-purpose input/output port
	INT4			External interrupt input pin
	SDA2			I ² C bus DATA input/output pin
57	P24_3	I/O	A	General-purpose input/output port
	INT3			External interrupt input pin
58	P24_2	I/O	A	General-purpose input/output port
	INT2			External interrupt input pin
59	P24_1	I/O	A	General-purpose input/output port
	INT1			External interrupt input pin
60	P20_0	I/O	A	General-purpose input/output port
	SIN2			Data input pin of USART2
	AIN0			Up/down counter input pin
61	P20_1	I/O	A	General-purpose input/output port
	SOT2			Data output pin of USART2
	BIN0			Up/down counter input pin
62	P20_2	I/O	A	General-purpose input/output port
	SCK2			Clock input/output pin of USART2
	ZIN0			Up/down counter input pin
	CK2			External clock input pin of free-run timer 2
63	P20_4	I/O	A	General-purpose input/output port
	SIN3			Data input pin of USART3
	AIN1			Up/down counter input pin
64	P20_5	I/O	A	General-purpose input/output port
	SOT3			Data output pin of USART3
	BIN1			Up/down counter input pin
65	P20_6	I/O	A	General-purpose input/output port
	SCK3			Clock input/output pin of USART3
	ZIN1			Up/down counter input pin
	CK3			External clock input pin of free-run timer 3
68	P23_0	I/O	A	General-purpose input/output port
	RX0			RX input/output pin of CAN0
	INT8			External interrupt input pin
69	P23_1	I/O	A	General-purpose input/output port
	TX0			TX output pin of CAN0

(Continued)

MB91460S Series

Pin no.	Pin name	I/O	I/O circuit type*	Function
70	P23_2	I/O	A	General-purpose input/output port
	RX1			RX input/output pin of CAN1
	INT9			External interrupt input pin
71	P23_3	I/O	A	General-purpose input/output port
	TX1			TX output pin of CAN1
72	P16_7	I/O	A	General-purpose input/output port
	PPG15			PPG timer output pin
	ATGX			A/D converter external trigger input pin
73	P16_6	I/O	A	General-purpose input/output port
	PPG14			Output pin of PPG timer
	PFM			Pulse frequency modulator output pin
74	P16_5	I/O	A	General-purpose input/output port
	PPG13			Output pin of PPG timer
	SGO			SGO output pin of sound generator
75	P16_4	I/O	A	General-purpose input/output port
	PPG12			Output pin of PPG timer
	SGA			SGA output pin of sound generator
76	P16_3	I/O	A	General-purpose input/output port
	PPG11			Output pin of PPG timer
77	P16_2	I/O	A	General-purpose input/output port
	PPG10			Output pin of PPG timer
78	P16_1	I/O	A	General-purpose input/output port
	PPG9			Output pin of PPG timer
79	P16_0	I/O	A	General-purpose input/output port
	PPG8			Output pin of PPG timer
80	P17_7	I/O	A	General-purpose input/output port
	PPG7			Output pin of PPG timer
	TCKI1			AIC downlink clock of Apix® link1
81	P17_6	I/O	A	General-purpose input/output port
	PPG6			Output pin of PPG timer
	TDA11			AIC downlink data of Apix® link1

(Continued)

MB91460S Series

Pin no.	Pin name	I/O	I/O circuit type*	Function
82	P17_5	I/O	A	General-purpose input/output port
	PPG5			Output pin of PPG timer
	TDA10			AIC downlink data of Apix® link1
83	P17_4	I/O	A	General-purpose input/output port
	PPG4			Output pin of PPG timer
84	P17_3	I/O	A	General-purpose input/output port
	PPG3			Output pin of PPG timer
85	P17_2	I/O	A	General-purpose input/output port
	PPG2			Output pin of PPG timer
	RDA11			AIC uplink data of Apix® link1
86	P17_1	I/O	A	General-purpose input/output port
	PPG1			Output pin of PPG timer
	RDA10			AIC uplink data of Apix® link1
87	P17_0	I/O	A	General-purpose input/output port
	PPG0			Output pin of PPG timer
	RCK1			AIC uplink clock of Apix® link1
90	MONCLK	O	M	Clock monitor pin
91	MD_3	I	G00	Fast clock input pin
92	X1	—	J1	Clock (oscillation) output
93	X0	—	J1	Clock (oscillation) input
95	X0A	—	J2	Sub clock (oscillation) input
96	X1A	—	J2	Sub clock (oscillation) output
97	INITX	I	H	External reset input pin
98	NMIX	I	H	Non-maskable interrupt input pin
100	SDINP		N1	Apix® uplink
101	SDINM		N1	Apix® uplink
102	SDOUTP		N2	Apix® downlink
103	SDOUTM		N2	Apix® downlink
112 to 114	MD_0 to MD_2	I	G01	Mode setting pins
115	P24_0	I/O	A	General-purpose input/output port
	INT0			External interrupt input pin

(Continued)

MB91460S Series

Pin no.	Pin name	I/O	I/O circuit type*	Function
116	P19_0	I/O	A	General-purpose input/output port
	SIN4			Data input pin of USART4
117	P19_1	I/O	A	General-purpose input/output port
	SOT4			Data output pin of USART4
118	P19_2	I/O	A	General-purpose input/output port
	SCK4			Clock input/output pin of USART4
	CK4			External clock input pin of free-run timer 4
119	P19_4	I/O	A	General-purpose input/output port
	SIN5			Data input pin of USART5
120	P19_5	I/O	A	General-purpose input/output port
	SOT5			Data output pin of USART5
121	P19_6	I/O	A	General-purpose input/output port
	SCK5			Clock input/output pin of USART5
	CK5			External clock input pin of free-run timer 5
122	P18_0	I/O	A	General-purpose input/output port
	SIN6			Data input pin of USART6
	AIN2			Up/down counter input pin
123	P18_1	I/O	A	General-purpose input/output port
	SOT6			Data output pin of USART6
	BIN2			Up/down counter input pin
124	P18_2	I/O	A	General-purpose input/output port
	SCK6			Clock input/output pin of USART6
	ZIN2			Up/down counter input pin
	CK6			External clock input pin of free-run timer 6
125	P18_4	I/O	A	General-purpose input/output port
	SIN7			Data input pin of USART7
	AIN3			Up/down counter input pin
126	P18_5	I/O	A	General-purpose input/output port
	SOT7			Data output pin of USART7
	BIN3			Up/down counter input pin

(Continued)

MB91460S Series

Pin no.	Pin name	I/O	I/O circuit type*	Function
127	P18_6	I/O	A	General-purpose input/output port
	SCK7			Clock input/output pin of USART7
	ZIN3			Up/down counter input pin
	CK7			External clock input pin of free-run timer 7
128	ALARM	I	N1	Alarm comparator input pin
134 to 141	P29_0 to P29_7	I/O	B	General-purpose input/output ports
	AN0 TO AN7			Analog input pins of A/D converter
142	P28_0	I/O	B	General-purpose input/output port
	AN8			Analog input pin of A/D converter
	RCK0			AIC uplink clock of Apix® link0
143	P28_1	I/O	B	General-purpose input/output port
	AN9			Analog input pin of A/D converter
	RDA00			AIC uplink data of Apix® link0
144	P28_2	I/O	B	General-purpose input/output port
	AN10			Analog input pin of A/D converter
	RDA01			AIC uplink data of Apix® link0
145	P28_3	I/O	B	General-purpose input/output port
	AN11			Analog input pin of A/D converter
146	P28_4	I/O	B	General-purpose input/output port
	AN12			Analog input pin of A/D converter
147	P28_5	I/O	B	General-purpose input/output port
	AN13			Analog input pin of A/D converter
	TDA00			AIC downlink data of Apix® link0
148	P28_6	I/O	B	General-purpose input/output port
	AN14			Analog input pin of A/D converter
	TDA01			AIC downlink data of Apix® link0
149	P28_7	I/O	B	General-purpose input/output port
	AN15			Analog input pin of A/D converter
	TCKI0			AIC downlink clock of Apix® link0
150	P23_4	I/O	A	General-purpose input/output port
	INT10			External interrupt input pin

(Continued)

(Continued)

Pin no.	Pin name	I/O	I/O circuit type*	Function
151	P23_6	I/O	A	General-purpose input/output port
	INT11			External interrupt input pin
152	P22_0	I/O	A	General-purpose input/output port
	INT12			External interrupt input pin
153	P22_2	I/O	A	General-purpose input/output port
	INT13			External interrupt input pin
156	P22_4	I/O	C	General-purpose input/output port
	SDA0			I ² C bus data input/output pin
	INT14			External interrupt input pin
157	P22_5	I/O	C	General-purpose input/output port
	SCL0			I ² C bus clock input/output pin
158	P22_6	I/O	C	General-purpose input/output port
	SDA1			I ² C bus data input/output pin
	INT15			External interrupt input pin
159	P22_7	I/O	C	General-purpose input/output port
	SCL1			I ² C bus clock input/output pin
160 to 163	P15_0 to P15_3	I/O	A	General-purpose input/output ports
	OCU0 to OCU3			Output compare output pins
	TOT0 to TOT3			Reload timer output pins
164 to 171	P14_0 to P14_7	I/O	A	General-purpose input/output ports
	ICU0 to ICU7			Input capture input pins
	TIN8/0 to TIN 15/7			External trigger input pins of reload timer
	TTG24/16/8/0 to TTG31/23/15/7			External trigger input pins of PPG timer
172 to 175	P07_0 to P07_3	I/O	A	General-purpose input/output ports
	A0 to A3			Signal pins of external address bus (bit0 to bit3)

MB91460S Series

[Power supply/Ground pins]

Pin no.	Pin name	I/O	Function
1, 23, 45, 67, 89, 94, 106, 111, 133, 155	VSS5	Supply	Ground pins
66, 88, 110, 132, 154	VDD5		Power supply pins
108, 109	VDD5R		Power supply pins for internal regulator
129	AVSS		Analog ground pin for A/D converter
131	AVCC5		Power supply pin for A/D converter
130	AVRH5		Reference power supply pin for A/D converter
107	VCC18C		Capacitor connection pin for internal regulator
22, 44, 176	VDD35		Power supply pins for external bus part of I/O ring
99, 105	VSSA		Apix [®] ground supply pins
104	VDDA		Apix [®] power supply pin

* : For information about the I/O circuit type, refer to "I/O CIRCUIT TYPES".

■ I/O CIRCUIT TYPES

Type	Circuit	Remarks
A	<p>pull-up control</p> <p>driver strength control</p> <p>data line</p> <p>pull-down control</p> <p>R</p> <p>CMOS hysteresis type1</p> <p>CMOS hysteresis type2</p> <p>Automotive inputs</p> <p>TTL input</p> <p>standby control for input shutdown</p>	<p>CMOS level output (programmable $I_{OL} = 5\text{mA}$, $I_{OH} = -5\text{mA}$ and $I_{OL} = 2\text{mA}$, $I_{OH} = -2\text{mA}$)</p> <p>2 different CMOS hysteresis inputs with input shutdown function</p> <p>Automotive input with input shutdown function</p> <p>TTL input with input shutdown function</p> <p>Programmable pull-up resistor: 50kΩ approx.</p>
B	<p>pull-up control</p> <p>driver strength control</p> <p>data line</p> <p>pull-down control</p> <p>R</p> <p>CMOS hysteresis type1</p> <p>CMOS hysteresis type2</p> <p>Automotive inputs</p> <p>TTL input</p> <p>standby control for input shutdown</p> <p>analog input</p>	<p>CMOS level output (programmable $I_{OL} = 5\text{mA}$, $I_{OH} = -5\text{mA}$ and $I_{OL} = 2\text{mA}$, $I_{OH} = -2\text{mA}$)</p> <p>2 different CMOS hysteresis inputs with input shutdown function</p> <p>Automotive input with input shutdown function)</p> <p>TTL input with input shutdown function</p> <p>Programmable pull-up resistor: 50kΩ approx.</p> <p>Analog input</p>

MB91460S Series

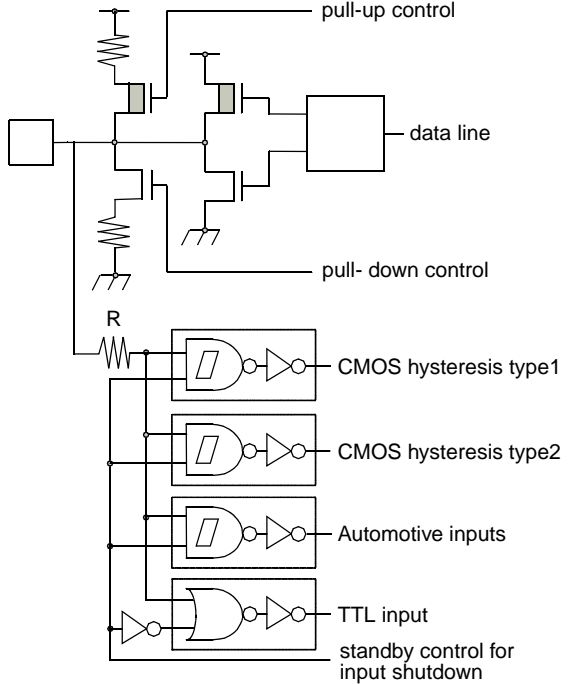
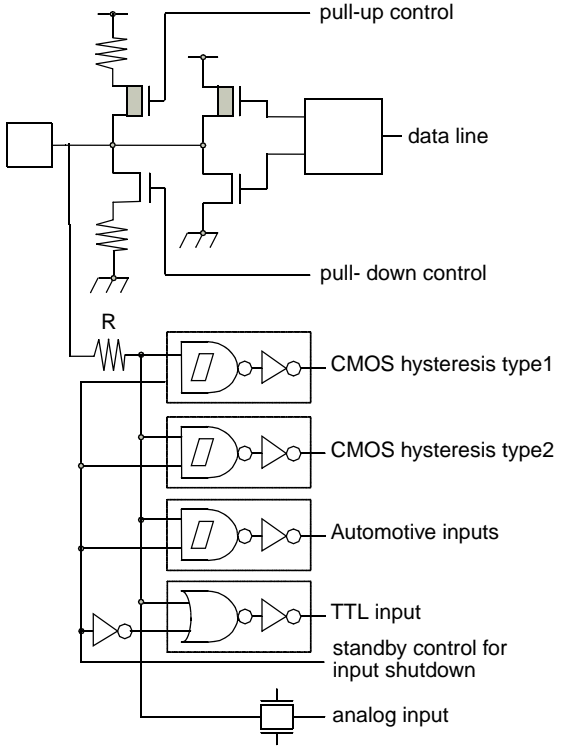
Type	Circuit	Remarks
C	 <p>The diagram for Type C shows an input pin connected to a pull-up resistor and a pull-down resistor. The pull-up resistor is controlled by a 'pull-up control' signal, and the pull-down resistor is controlled by a 'pull-down control' signal. The input signal is connected to a data line through a resistor 'R'. Below the input pin, there are four input types: CMOS hysteresis type1, CMOS hysteresis type2, Automotive inputs, and TTL input. A 'standby control for input shutdown' signal is also shown, which is connected to the input pin through a resistor.</p>	<p>CMOS level output ($I_{OL} = 3mA$, $I_{OH} = -3mA$) 2 different CMOS hysteresis inputs with input shutdown function Automotive input with input shutdown function TTL input with input shutdown function Programmable pull-up resistor: 50kΩ approx.</p>
D	 <p>The diagram for Type D is similar to Type C, but it includes an 'analog input' at the bottom. The input pin is connected to a pull-up resistor and a pull-down resistor. The pull-up resistor is controlled by a 'pull-up control' signal, and the pull-down resistor is controlled by a 'pull-down control' signal. The input signal is connected to a data line through a resistor 'R'. Below the input pin, there are four input types: CMOS hysteresis type1, CMOS hysteresis type2, Automotive inputs, and TTL input. A 'standby control for input shutdown' signal is also shown, which is connected to the input pin through a resistor. An 'analog input' is also shown, which is connected to the input pin through a resistor.</p>	<p>CMOS level output ($I_{OL} = 3mA$, $I_{OH} = -3mA$) 2 different CMOS hysteresis inputs with input shutdown function Automotive input with input shutdown function TTL input with input shutdown function Programmable pull-up resistor: 50kΩ approx. Analog input</p>

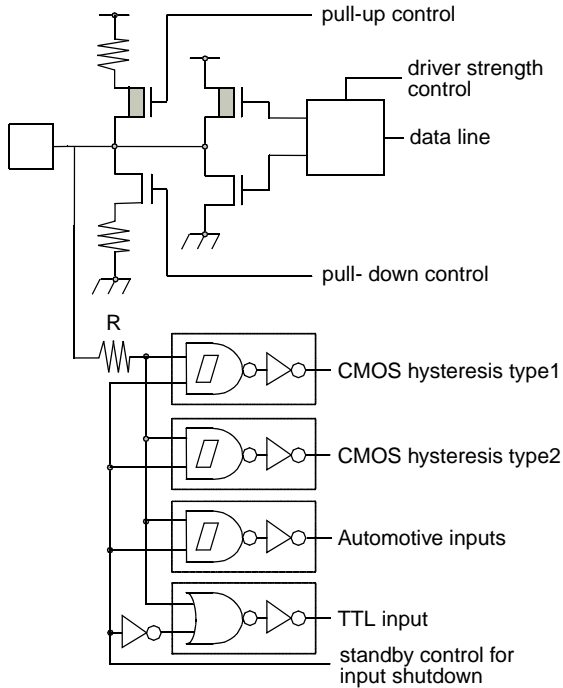
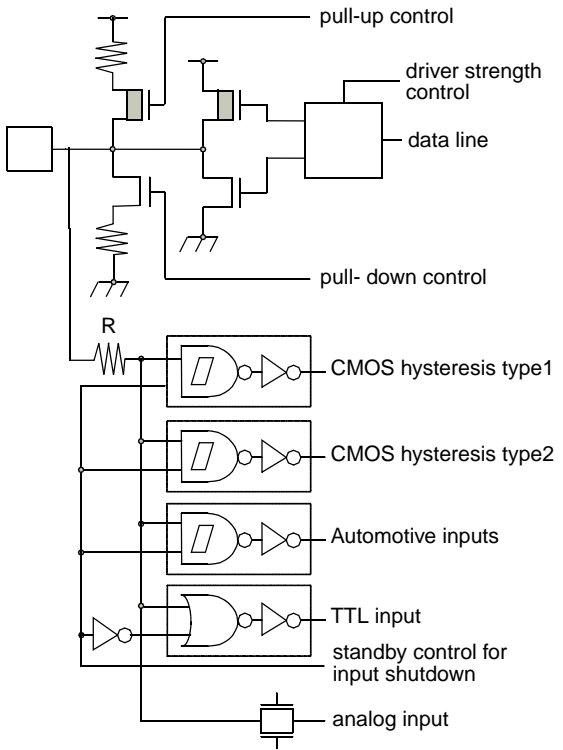
Type	Circuit	Remarks
E	 <p>pull-up control</p> <p>driver strength control</p> <p>data line</p> <p>pull- down control</p> <p>R</p> <p>CMOS hysteresis type1</p> <p>CMOS hysteresis type2</p> <p>Automotive inputs</p> <p>TTL input</p> <p>standby control for input shutdown</p>	<p>CMOS level output (programmable $I_{OL} = 5\text{mA}$, $I_{OH} = -5\text{mA}$ and $I_{OL} = 2\text{mA}$, $I_{OH} = -2\text{mA}$, and $I_{OL} = 30\text{mA}$, $I_{OH} = -30\text{mA}$)</p> <p>2 different CMOS hysteresis inputs with input shutdown function</p> <p>Automotive input with input shutdown function</p> <p>TTL input with input shutdown function</p> <p>Programmable pull-up resistor: 50kΩ approx.</p>
F	 <p>pull-up control</p> <p>driver strength control</p> <p>data line</p> <p>pull- down control</p> <p>R</p> <p>CMOS hysteresis type1</p> <p>CMOS hysteresis type2</p> <p>Automotive inputs</p> <p>TTL input</p> <p>standby control for input shutdown</p> <p>analog input</p>	<p>CMOS level output (programmable $I_{OL} = 5\text{mA}$, $I_{OH} = -5\text{mA}$ and $I_{OL} = 2\text{mA}$, $I_{OH} = -2\text{mA}$, and $I_{OL} = 30\text{mA}$, $I_{OH} = -30\text{mA}$)</p> <p>2 different CMOS hysteresis inputs with input shutdown function</p> <p>Automotive input with input shutdown function</p> <p>TTL input with input shutdown function</p> <p>Programmable pull-up resistor: 50kΩ approx.</p> <p>Analog input</p>

MB91460S Series

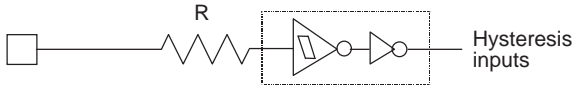
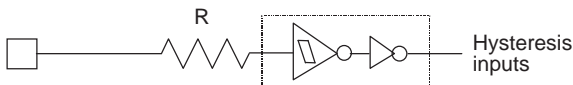
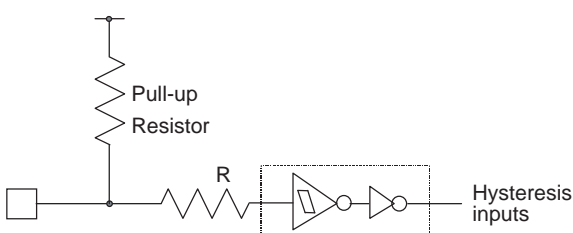
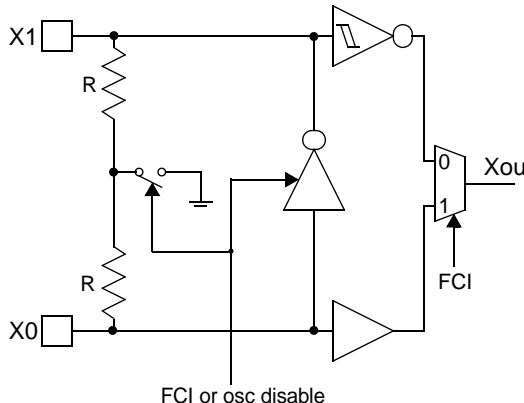
Type	Circuit	Remarks
G00		CMOS Hysteresis input pin
G01		Mask ROM and EVA device: CMOS Hysteresis input pin Flash device: CMOS input pin 12 V resistant (for MD_[2:0])
H		CMOS Hysteresis input pin Pull-up resistor value: 50 kΩ approx.
J1		High-speed oscillation circuit: Programmable between oscillation mode (external crystal or resonator connected to X0/ X1 pins) and Fast external Clock Input (FCI) mode (external clock connected to X0 pin) Feedback resistor = approx. 2 * 0.5 MΩ. Feedback resistor is grounded in the center when the oscillator is disabled or in FCI mode.

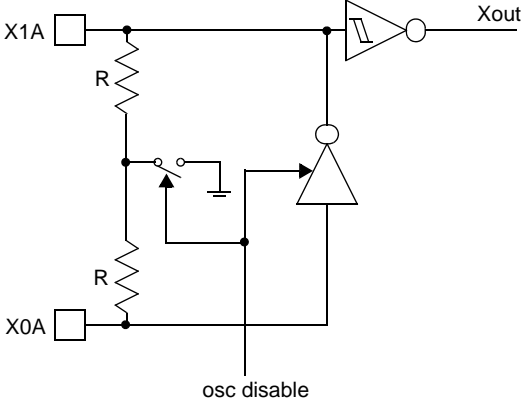
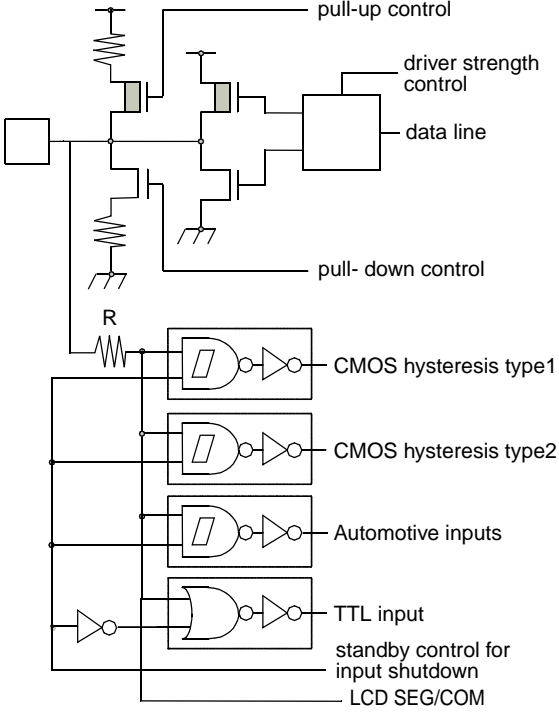
Type	Circuit	Remarks
J2		<p>Low-speed oscillation circuit: Feedback resistor = approx. $2 * 5 \text{ M}\Omega$. Feedback resistor is grounded in the center when the oscillator is disabled.</p>
K		<p>CMOS level output (programmable $I_{OL} = 5\text{mA}$, $I_{OH} = -5\text{mA}$ and $I_{OL} = 2\text{mA}$, $I_{OH} = -2\text{mA}$) 2 different CMOS hysteresis inputs with input shutdown function Automotive input with input shutdown function TTL input with input shutdown function Programmable pull-up resistor: $50\text{k}\Omega$ approx. LCD SEG/COM output</p>

MB91460S Series

Type	Circuit	Remarks
L	<p>The diagram for Type L shows a CMOS driver circuit. It includes a pull-up control, pull-down control, driver strength control, and a data line. Below the driver, there are four input configurations: CMOS hysteresis type 1, CMOS hysteresis type 2, Automotive inputs, and TTL input. A standby control for input shutdown and VLCD are also shown.</p>	<p>CMOS level output (programmable $I_{OL} = 5\text{mA}$, $I_{OH} = -5\text{mA}$ and $I_{OL} = 2\text{mA}$, $I_{OH} = -2\text{mA}$) 2 different CMOS hysteresis inputs with input shutdown function Automotive input with input shutdown function) TTL input with input shutdown function Programmable pull-up resistor: 50kΩ approx. Analog input LCD Voltage input</p>
M	<p>The diagram for Type M shows a CMOS driver circuit with a tri-state control and a data line.</p>	<p>CMOS level tri-state output ($I_{OL} = 5\text{mA}$, $I_{OH} = -5\text{mA}$)</p>
N1/N2	<p>The diagram for Type N1/N2 shows an analog terminal with protection and an analog line.</p>	<p>Analog terminal Type N1: Analog input pin with protection Type N2: Analog output line with protection</p>

■ HANDLING DEVICES

1. Preventing Latch-up

Latch-up may occur in a CMOS IC if a voltage higher than (V_{DD5} or V_{DD35}) or less than (V_{SS5}) is applied to an input or output pin or if a voltage exceeding the rating is applied between the power supply pins and ground pins. If latch-up occurs, the power supply current increases rapidly, sometimes resulting in thermal breakdown of the device. Therefore, be very careful not to apply voltages in excess of the absolute maximum ratings.

2. Handling of unused input pins

If unused input pins are left open, abnormal operation may result. Any unused input pins should be connected to pull-up or pull-down resistor ($2K\Omega$ to $10K\Omega$) or enable internal pullup or pulldown resistors (PPER/PPCR) before the input enable (PORTEN) is activated by software. The mode pins MD_x can be connected to V_{SS5} or V_{DD5} directly. Unused ALARM input pins can be connected to AV_{SS} directly.

3. Power supply pins

In MB91460S series, devices including multiple power supply pins and ground pins are designed as follows; pins necessary to be at the same potential are interconnected internally to prevent malfunctions such as latch-up. All of the power supply pins and ground pins must be externally connected to the power supply and ground respectively in order to reduce unnecessary radiation, to prevent strobe signal malfunctions due to the ground level rising and to follow the total output current ratings. Furthermore, the power supply pins and ground pins of the MB91460S series must be connected to the current supply source via a low impedance.

It is also recommended to connect a ceramic capacitor of approximately $0.1\ \mu\text{F}$ as a bypass capacitor between power supply pin and ground pin near this device.

This series has a built-in step-down regulator. Connect a bypass capacitor of $4.7\ \mu\text{F}$ (use a X7R ceramic capacitor) to VCC18C pin for the regulator.

4. Crystal oscillator circuit

Noise in proximity to the X0 (X0A) and X1 (X1A) pins can cause the device to operate abnormally. Printed circuit boards should be designed so that the X0 (X0A) and X1 (X1A) pins, and crystal oscillator, as well as bypass capacitors connected to ground, are located near the device and ground.

It is recommended that the printed circuit board layout be designed such that the X0 and X1 pins or X0A and X1A pins are surrounded by ground plane for the stable operation.

Please request the oscillator manufacturer to evaluate the oscillational characteristics of the crystal and this device.

5. Notes on using external clock

5.1. Opposite phase clock supply

When using the external clock, it is possible to simultaneously supply the X0 (X0A) and the X1 (X1A) pins. In the described combination X0 (X0A) should be supplied with a clock signal which has the opposite phase to the X1 (X1A) pins. However, in this case the stop mode (oscillation stop mode) must not be used (This is because the X1 (X1A) pin stops at "H" output in STOP mode).

With opposite phase supply at X0 and X1, a frequency up to 16 MHz is possible.

Example of using opposite phase supply

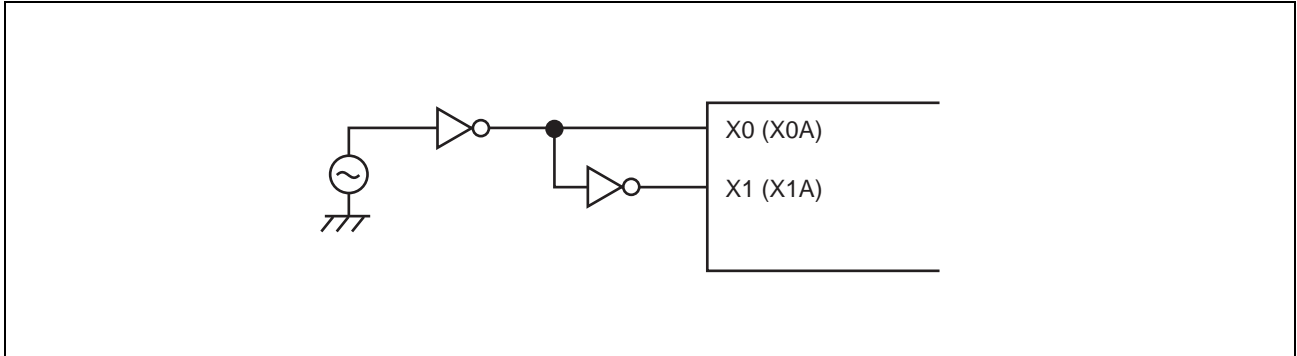

5.2. Single phase clock supply

For lower frequencies, up to 4 MHz, it is possible to supply a single phase clock at X0 (X0A).

Example of using single phase supply

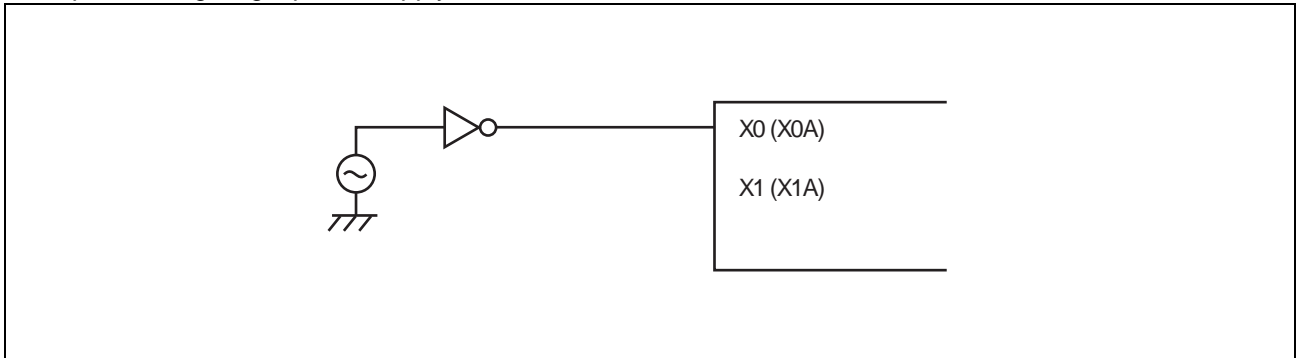

6. Mode pins (MD_x)

These pins should be connected directly to the power supply or ground pins. To prevent the device from entering test mode accidentally due to noise, minimize the lengths of the patterns between each mode pin and power supply pin or ground pin on the printed circuit board as possible and connect them with low impedance.

MD_3 pin should be connected directly to ground.

7. Notes on operating in PLL clock mode

If the oscillator is disconnected or the clock input stops when the PLL clock is selected, the microcontroller may continue to operate at the free-running frequency of the self-oscillating circuit of the PLL. However, this self-running operation cannot be guaranteed.

8. Pull-up control

The AC standard is not guaranteed in case a pull-up resistor is connected to the pin serving as an external bus pin.

9. Notes on PS register

As the PS register is processed in advance by some instructions, when the debugger is being used, the exception handling may result in execution breaking in an interrupt handling routine or the displayed values of the flags in the PS register being updated.

As the microcontroller is designed to carry out reprocessing correctly upon returning from such an EIT event, the operation before and after the EIT always proceeds according to specification.

1) The following behavior may occur if any of the following occurs in the instruction immediately after a DIV0U/DIV0S instruction:

(a) a user interrupt or NMI is accepted; (b) single-step execution is performed; or (c) execution breaks due to a data event or from the emulator menu.

- D0 and D1 flags are updated in advance.
- An EIT handling routine (user interrupt/NMI or emulator) is executed.
- Upon returning from the EIT, the DIV0U/DIV0S instruction is executed and the D0 and D1 flags are updated to the same values as those in 1).

2) The following behavior occurs when an ORCCR, STILM, MOV Ri, PS instruction is executed to enable a user interrupt or NMI source while that interrupt is in the active state.

- The PS register is updated in advance.
- An EIT handling routine (user interrupt/NMI or emulator) is executed.
- Upon returning from the EIT, the above instructions are executed and the PS register is updated to the same value as in 1).

■ NOTES ON DEBUGGER

1. Execution of the RETI Command

If single-step execution is used in an environment where an interrupt occurs frequently, the corresponding interrupt handling routine will be executed repeatedly to the exclusion of other processing. This will prevent the main routine and the handlers for low priority level interrupts from being executed (For example, if the time-base timer interrupt is enabled, stepping over the RETI instruction will always break on the first line of the time-base timer interrupt handler).

Disable the corresponding interrupts when the corresponding interrupt handling routine no longer needs debugging.

2. Break function

If the range of addresses that cause a hardware break (including event breaks) is set to the address of the current system stack pointer or to an area that contains the stack pointer, execution will break after each instruction regardless of whether the user program actually contains data access instructions.

To prevent this, do not set (word) access to the area containing the address of the system stack pointer as the target of the hardware break (including an event breaks).

3. Operand break

It may cause malfunctions if a stack pointer exists in the area which is set as the DSU operand break. Do not set the access to the areas containing the address of system stack pointer as a target of data event break.

■ BLOCK DIAGRAM

1. MB91F467SA

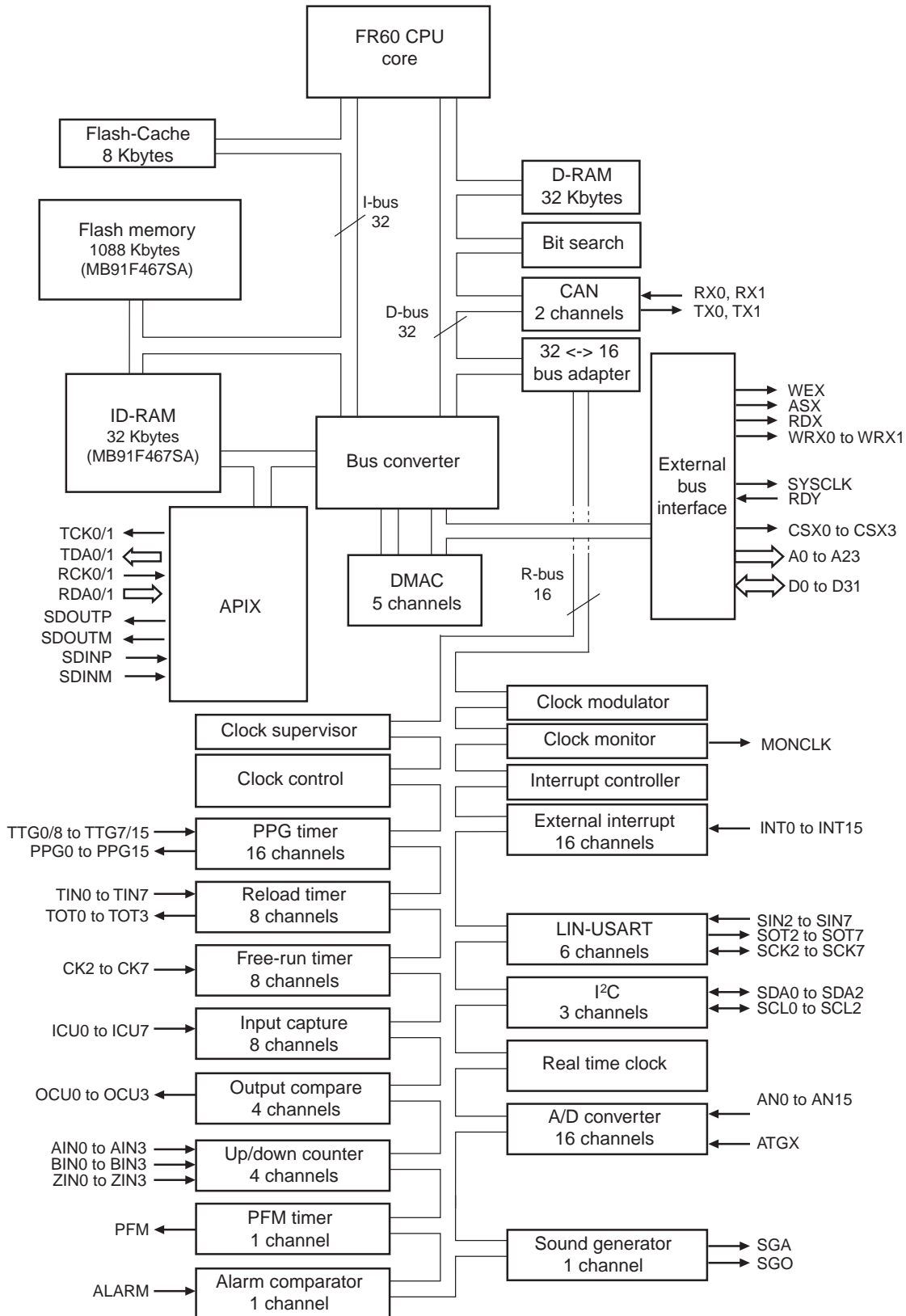

■ CPU AND CONTROL UNIT

The FR family CPU is a high performance core that is designed based on the RISC architecture with advanced instructions for embedded applications.

1. Features

- Adoption of RISC architecture
Basic instruction: 1 instruction per cycle
- General-purpose registers: 32-bit × 16 registers
- 4 Gbytes linear memory space
- Multiplier installed
32-bit × 32-bit multiplication: 5 cycles
16-bit × 16-bit multiplication: 3 cycles
- Enhanced interrupt processing function
Quick response speed (6 cycles)
Multiple-interrupt support
Level mask function (16 levels)
- Enhanced instructions for I/O operation
Memory-to-memory transfer instruction
Bit processing instruction
- Basic instruction word length: 16 bits
- Low-power consumption
Sleep mode/stop mode

2. Internal architecture

- The FR family CPU uses the Harvard architecture in which the instruction bus and data bus are independent of each other.
- A 32-bit ↔ 16-bit buffer is connected to the 32-bit bus (D-bus) to provide an interface between the CPU and peripheral resources.
- A Harvard ↔ Princeton bus converter is connected to both the I-bus and D-bus to provide an interface between the CPU and the bus controller.

3. Programming model

3.1. Basic programming model

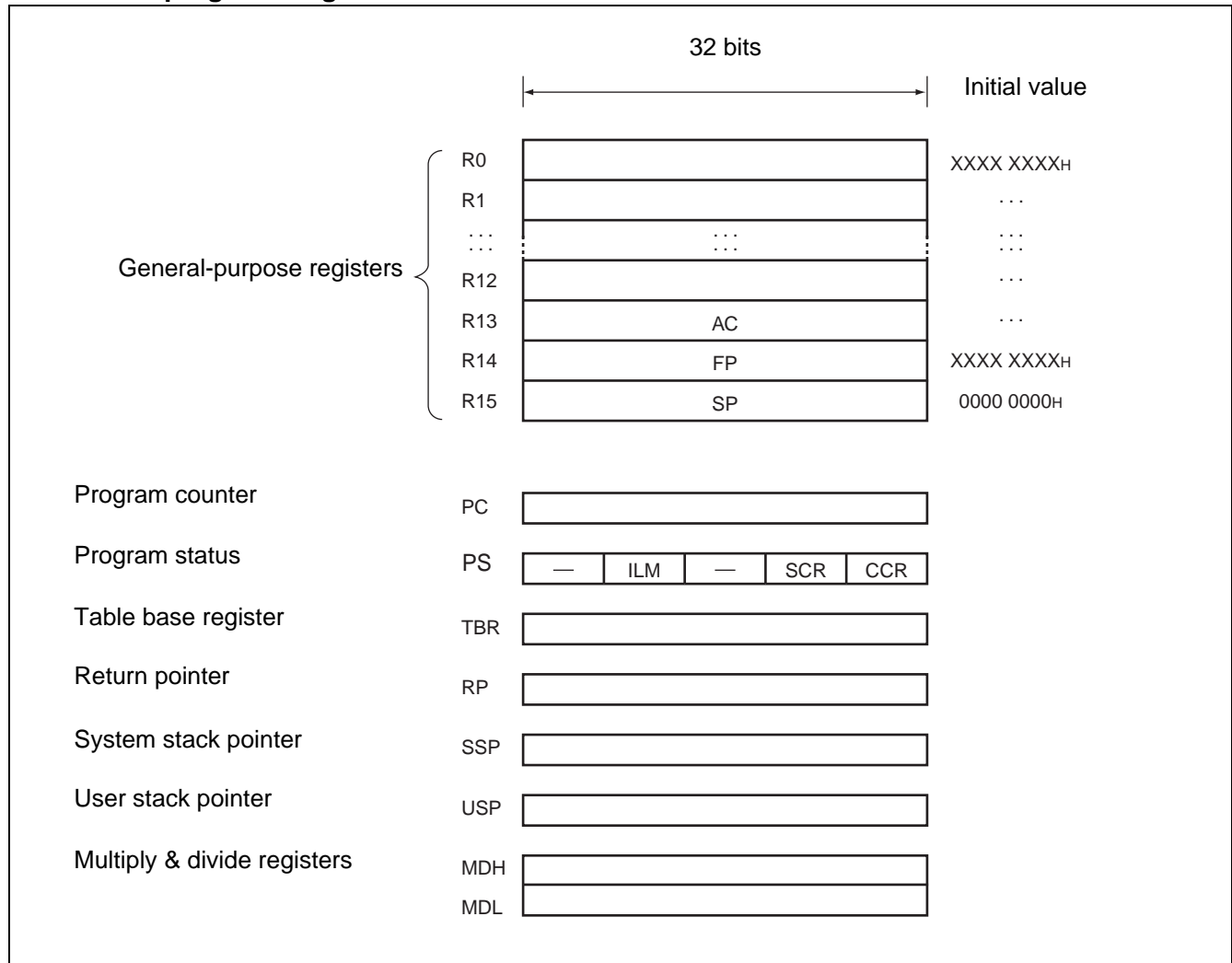

4. Registers

4.1. General-purpose register

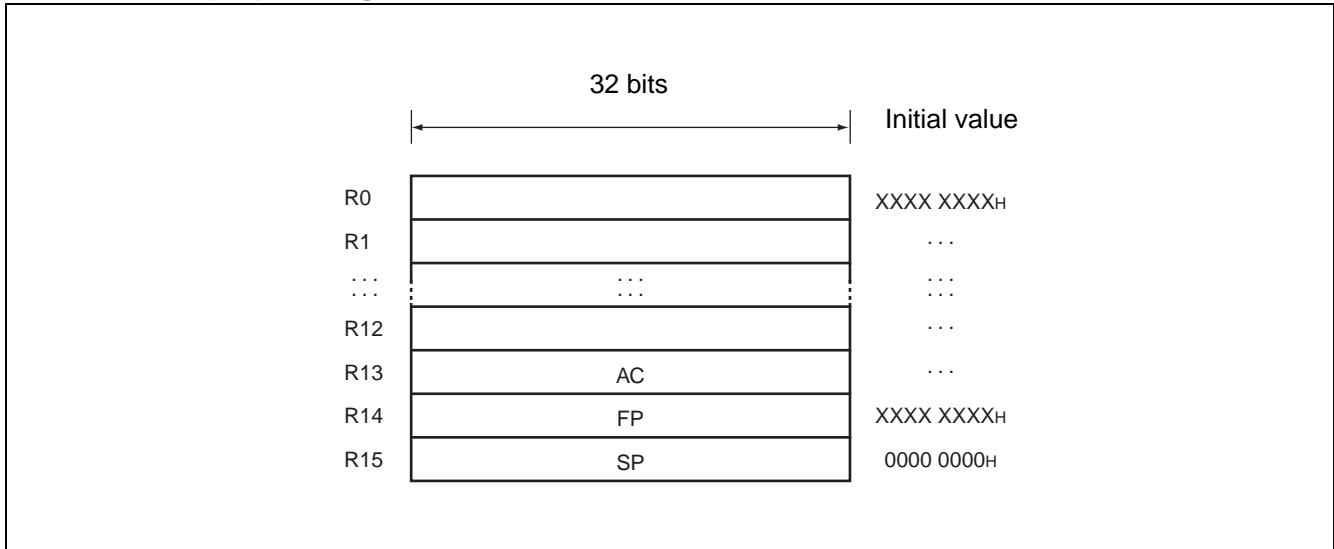

Registers R0 to R15 are general-purpose registers. These registers can be used as accumulators for computation operations and as pointers for memory access.

Of the 16 registers, enhanced commands are provided for the following registers to enable their use for particular applications.

- R13 : Virtual accumulator
- R14 : Frame pointer
- R15 : Stack pointer

Initial values at reset are undefined for R0 to R14. The value for R15 is 00000000H (SSP value).

4.2. PS (Program Status)

This register holds the program status, and is divided into three parts, ILM, SCR, and CCR.

All undefined bits (-) in the diagram are reserved bits. The read values are always "0". Write access to these bits is invalid.

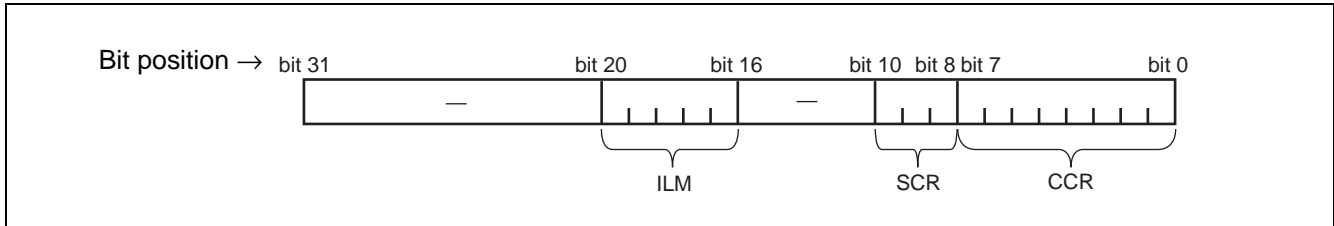

4.3. CCR (Condition Code Register)

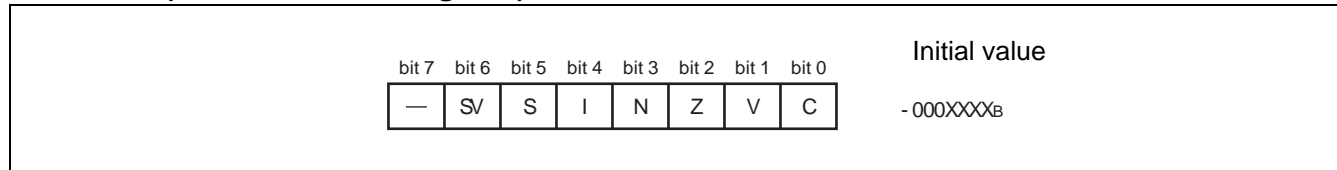

- SV : Supervisor flag
- S : Stack flag
- I : Interrupt enable flag
- N : Negative enable flag
- Z : Zero flag
- V : Overflow flag
- C : Carry flag

4.4. SCR (System Condition Register)

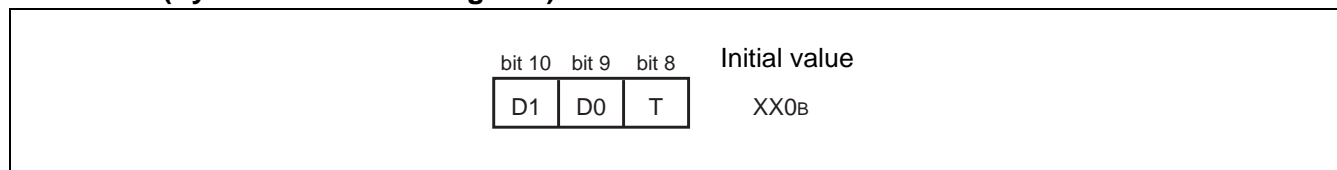

Flag for step multiplication (D1, D0)

This flag stores interim data during execution of step multiplication.

Step trace trap flag (T)

This flag indicates whether the step trace trap is enabled or disabled.

The step trace trap function is used by emulators. When an emulator is in use, it cannot be used in execution of user programs.

4.5. ILM (Interrupt Level Mask register)

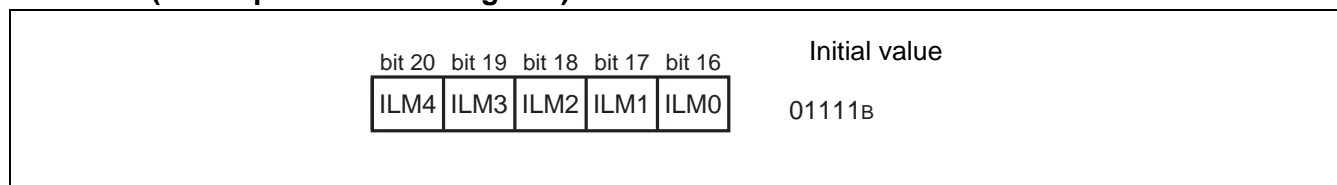

This register stores interrupt level mask values, and the values stored in ILM4 to ILM0 are used for level masking.

The register is initialized to value "01111_B" at reset.

4.6. PC (Program Counter)

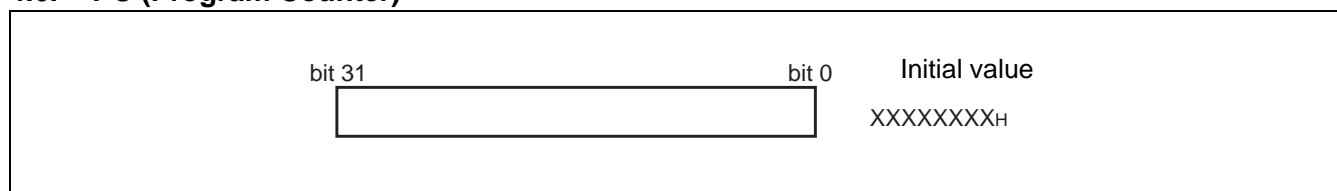

The program counter indicates the address of the instruction that is being executed.

The initial value at reset is undefined.

4.7. TBR (Table Base Register)

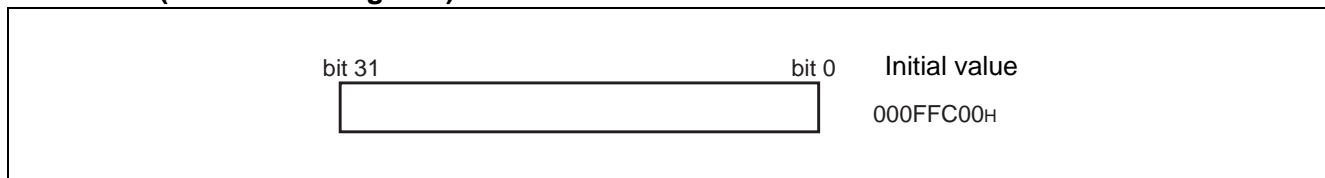

The table base register stores the starting address of the vector table used in EIT processing.
The initial value at reset is 000FFC00H.

4.8. RP (Return Pointer)

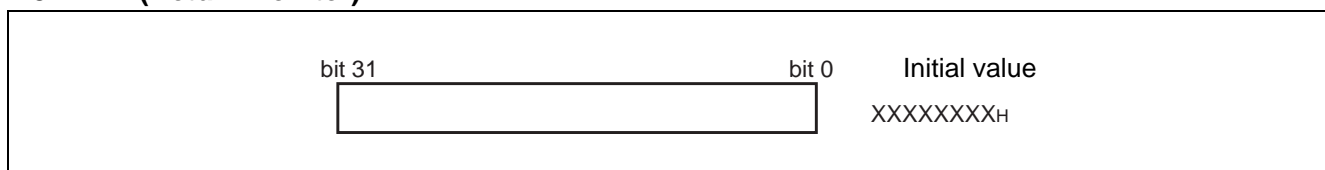

The return pointer stores the address for return from subroutines.
During execution of a CALL instruction, the PC value is transferred to this RP register.
During execution of a RET instruction, the contents of the RP register are transferred to PC.
The initial value at reset is undefined.

4.9. USP (User Stack Pointer)

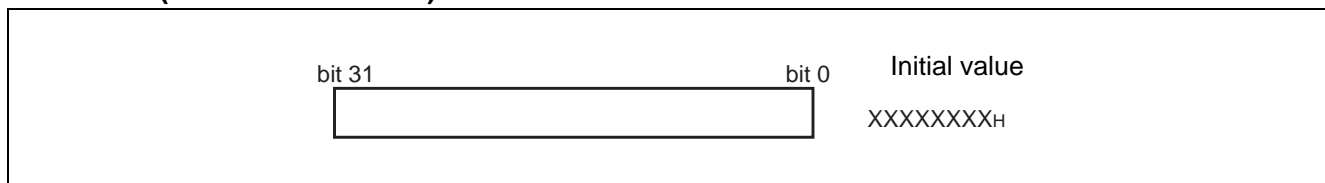

The user stack pointer, when the S flag is "1", this register functions as the R15 register.

- The USP register can also be explicitly specified.
The initial value at reset is undefined.
- This register cannot be used with RETI instructions.

4.10. Multiply & divide registers

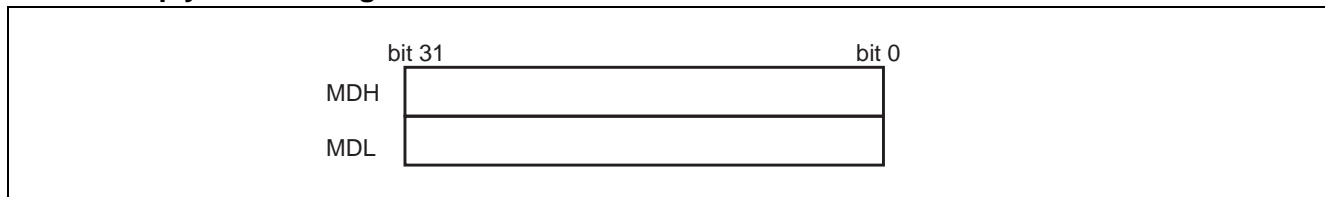

These registers are for multiplication and division, and are each 32 bits in length.
The initial value at reset is undefined.

■ EMBEDDED PROGRAM/DATA MEMORY (FLASH)

1. Flash features

- MB91F467SA: 1088 Kbytes (16×64 Kbytes + 8×8 Kbytes = 8.5 Mbits)
- Programmable wait state for read/write access
- Flash and Boot security with security vector at 0x0014:8000 - 0x0014:800F
- Boot security
- Basic specification: Same as MBM29LV400TC (except size and part of sector configuration)

2. Operation modes

(1) 64-bit CPU mode :

- CPU reads and executes programs in word (32-bit) length units.
- Flash writing is not possible.
- Actual Flash Memory access is performed in d-word (64-bit) length units.

(2) 32-bit CPU mode :

- CPU reads, writes and executes programs in word (32-bit) length units.
- Actual Flash Memory access is performed in word (32-bit) length units.

(3) 16-bit CPU mode :

- CPU reads and writes in half-word (16-bit) length units.
- Program execution from the Flash is not possible.
- Actual Flash Memory access is performed in word (16-bit) length units.

MB91460S Series

3. Flash access in CPU mode

3.1. Flash configuration

3.1.1. Flash memory map MB91F467SA

Address									
0014:FFFFh 0014:C000h	SA6 (8KB)				SA7 (8KB)				ROMS7
0014:BFFFh 0014:8000h	SA4 (8KB)				SA5 (8KB)				
0014:7FFFh 0014:4000h	SA2 (8KB)				SA3 (8KB)				
0014:3FFFh 0014:0000h	SA0 (8KB)				SA1 (8KB)				
0013:FFFFh 0012:0000h	SA22 (64KB)				SA23 (64KB)				ROMS6
0011:FFFFh 0010:0000h	SA20 (64KB)				SA21 (64KB)				
000F:FFFFh 000E:0000h	SA18 (64KB)				SA19 (64KB)				ROMS5
000D:FFFFh 000C:0000h	SA16 (64KB)				SA17 (64KB)				ROMS4
000B:FFFFh 000A:0000h	SA14 (64KB)				SA15 (64KB)				ROMS3
0009:FFFFh 0008:0000h	SA12 (64KB)				SA13 (64KB)				ROMS2
0007:FFFFh 0006:0000h	SA10 (64KB)				SA11 (64KB)				ROMS1
0005:FFFFh 0004:0000h	SA8 (64KB)				SA9 (64KB)				ROMS0
	addr+0	addr+1	addr+2	addr+3	addr+4	addr+5	addr+6	addr+7	
16bit read/write	dat[31:16]		dat[15:0]		dat[31:16]		dat[15:0]		
32bit read/write	dat[31:0]				dat[31:0]				
64bit read	dat[63:0]								

3.2. Flash access timing settings in CPU mode

The following tables list all settings for a given maximum Core Frequency (through the setting of CLKB or maximum clock modulation) for Flash read and write access.

3.2.1. Flash read timing settings (synchronous read)

Core clock (CLKB)	ATD	ALEH	EQ	WEXH	WTC	Remark
to 24 MHz	0	0	0	0	1	
to 48 MHz	0	0	1	0	2	
to 96 MHz	1	1	3	0	4	
to 100 MHz	1	1	3	0	4	

3.2.2. Flash write timing settings (synchronous write)

Core clock (CLKB)	ATD	ALEH	EQ	WEXH	WTC	Remark
to 32 MHz	1	0	1	0	4	
to 48 MHz	1	0	3	0	5	
to 64 MHz	1	1	3	0	6	
to 96 MHz	1	1	3	0	7	
to 100 MHz	1	1	3	0	7	

3.3. Address mapping from CPU to parallel programming mode

The following tables show the calculation from CPU addresses to flash macro addresses which are used in parallel programming.

3.3.1. Address mapping MB91F467SA

CPU Address (addr)	Condition	Flash sectors	FA (flash address) Calculation
14:0000h to 14:FFFFh	addr[2]==0	SA0, SA2, SA4, SA6 (8 Kbyte)	$FA := addr - addr\%00:4000h + (addr\%00:4000h)/2 - (addr/2)\%4 + addr\%4 - 05:0000h$
14:0000h to 14:FFFFh	addr[2]==1	SA1, SA3, SA5, SA7 (8 Kbyte)	$FA := addr - addr\%00:4000h + (addr\%00:4000h)/2 - (addr/2)\%4 + addr\%4 - 05:0000h + 00:2000h$
04:0000h to 13:FFFFh	addr[2]==0	SA8, SA10, SA12, SA14, SA16, SA18, SA20, SA22 (64 Kbyte)	$FA := addr - addr\%02:0000 + (addr\%02:0000h)/2 - (addr/2)\%4 + addr\%4 + 0C:0000h$
04:0000h to 13:FFFFh	addr[2]==1	SA9, SA11, SA13, SA15, SA17, SA19, SA21, SA23 (64 Kbyte)	$FA := addr - addr\%02:0000h + (addr\%02:0000h)/2 - (addr/2)\%4 + addr\%4 + 0C:0000h + 01:0000h$

Note: FA result is without 20:0000h offset for parallel Flash programming .

Set offset by keeping FA[21] = 1 as described in section "Parallel Flash programming mode".

MB91460S Series

4. Parallel Flash programming mode

4.1. Flash configuration in parallel Flash programming mode

Parallel Flash programming mode (MD_[2:0] = 111):

MB91F467SA

FA[21:0]		
003F:FFFFh 003F:0000h	SA23 (64KB)	
003E:FFFFh 003E:0000h	SA22 (64KB)	
003D:FFFFh 003D:0000h	SA21 (64KB)	
003C:FFFFh 003C:0000h	SA20 (64KB)	
003B:FFFFh 003B:0000h	SA19 (64KB)	
003A:FFFFh 003A:0000h	SA18 (64KB)	
0039:FFFFh 0039:0000h	SA17 (64KB)	
0038:FFFFh 0038:0000h	SA16 (64KB)	
0037:FFFFh 0037:0000h	SA15 (64KB)	
0036:FFFFh 0036:0000h	SA14 (64KB)	
0035:FFFFh 0035:0000h	SA13 (64KB)	
0034:FFFFh 0034:0000h	SA12 (64KB)	
0033:FFFFh 0033:0000h	SA11 (64KB)	
0032:FFFFh 0032:0000h	SA10 (64KB)	
0031:FFFFh 0031:0000h	SA9 (64KB)	
0030:FFFFh 0030:0000h	SA8 (64KB)	
002F:FFFFh 002F:E000h	SA7 (8KB)	
002F:DFFFh 002F:C000h	SA6 (8KB)	
002F:BFFFh 002F:A000h	SA5 (8KB)	
002F:9FFFh 002F:8000h	SA4 (8KB)	
002F:7FFFh 002F:6000h	SA3 (8KB)	
002F:5FFFh 002F:4000h	SA2 (8KB)	
002F:3FFFh 002F:2000h	SA1 (8KB)	
002F:1FFFh 002F:0000h	SA0 (8KB)	
	FA[1:0]=00	FA[1:0]=10
16bit write mode	DQ[15:0]	DQ[15:0]

Remark: Always keep FA[0] = 0 and FA[21] = 1

4.2. Pin connections in parallel programming mode

Resetting after setting the MD_[2:0] pins to [111] will halt CPU functioning. At this time, the Flash memory's interface circuit enables direct control of the Flash memory unit from external pins by directly linking some of the signals to GP-Ports. Please see table below for signal mapping.

In this mode, the Flash memory appears to the external pins as a stand-alone unit. This mode is generally set when writing/erasing using the parallel Flash programmer. In this mode, all operations of the 8.5 Mbits Flash memory's Auto Algorithms are available.

Correspondence between MBM29LV400TC and Flash Memory Control Signals

MBM29LV400TC External pins	FR-CPU mode	MB91F467SA external pins			Comment
		Flash memory mode	Normal function	Pin number	
—	INITX	—	INITX	97	
RESET	—	FRSTX	NMIX	98	
—	—	MD2	MD2	114	
—	—	MD1	MD1	113	
—	—	MD0	MD0	112	
RY/BY	FMCS:RDY bit	RY/BYX	GP19_1	117	
BYTE	Internally fixed to 'H'	BYTEX	GP19_2	118	
WE	Internal control signal + control via interface circuit	WEX	GP18_0	122	
OE		OEX	GP19_6	121	
CE		CEX	GP19_5	120	
—		ATDIN	MD3	91	
—		EQIN	MONCLK	90	
—		TESTX	GP19_4	119	
—		RDYI	GP19_1	117	
A-1		Internal address bus	FA0	GP09_1	41
A0 to A3	FA1 to FA4		GP06_0 to GP06_3	6 to 9	
A4 to A7	FA5 to FA8		GP06_4 to GP06_7	10 to 13	
A8 to A11	FA9 to FA12		GP05_0 to GP05_3	14 to 17	
A12 to A15	FA13 to FA16		GP05_4 to GP05_7	18 to 21	
A16 to A19	FA17 to FA20		GP07_0 to GP07_3	172 to 175	
—	FA21		GP09_0	40	
DQ0 to DQ7	Internal data bus	DQ0 to DQ7	GP01_0 to GP01_7	24 to 31	
DQ8 to DQ15		DQ8 to DQ15	GP00_0 to GP00_7	32 to 39	

5. Flash Security

5.1. Vector addresses

Two Flash Security Vectors (FSV1, FSV2) are located parallel to the Boot Security Vectors (BSV1, BSV2) controlling the protection functions of the Flash Security Module:

FSV1: 0x14:8000 BSV1: 0x14:8004

FSV2: 0x14:8008 BSV2: 0x14:800C

5.2. Security Vector FSV1

The setting of the Flash Security Vector FSV1 is responsible for the read and write protection modes and the individual write protection of the 8 Kbytes sectors.

5.2.1. FSV1 (bit31 to bit16)

The setting of the Flash Security Vector FSV1 bits [31:16] is responsible for the read and write protection modes.

Explanation of the bits in the Flash Security Vector FSV1 [31:16]

FSV1[31:19]	FSV1[18] Write Protection Level	FSV1[17] Write Protection	FSV1[16] Read Protection	Flash Security Mode
set all to "0"	set to "0"	set to "0"	set to "1"	Read Protection (all device modes, except INTVEC mode MD_[2:0] = "000")
set all to "0"	set to "0"	set to "1"	set to "0"	Write Protection (all device modes, without exception)
set all to "0"	set to "0"	set to "1"	set to "1"	Read Protection (all device modes, except INTVEC mode MD_[2:0] = "000") and Write Protection (all device modes)
set all to "0"	set to "1"	set to "0"	set to "1"	Read Protection (all device modes, except INTVEC mode MD_[2:0] = "000")
set all to "0"	set to "1"	set to "1"	set to "0"	Write Protection (all device modes, except INTVEC mode MD_[2:0] = "000")
set all to "0"	set to "1"	set to "1"	set to "1"	Read Protection (all device modes, except INTVEC mode MD_[2:0] = "000") and Write Protection (all device modes except INTVEC mode MD_[2:0] = "000")

5.2.2. FSV1 (bit15 to bit0)

The setting of the Flash Security Vector FSV1 bits [15:0] is responsible for the individual write protection of the 8 Kbytes sectors. It is only evaluated if write protection bit FSV1[17] is set.

Explanation of the bits in the Flash Security Vector FSV1 [15:0]

FSV1 bit	Sector	Enable Write Protection	Disable Write Protection	Comment
FSV1[0]	SA0	set to "0"	set to "1"	
FSV1[1]	SA1	set to "0"	set to "1"	
FSV1[2]	SA2	set to "0"	set to "1"	
FSV1[3]	SA3	set to "0"	set to "1"	
FSV1[4]	SA4	set to "0"	—	Write protection is mandatory!
FSV1[5]	SA5	set to "0"	set to "1"	
FSV1[6]	SA6	set to "0"	set to "1"	
FSV1[7]	SA7	set to "0"	set to "1"	
FSV1[8]	—	set to "0"	set to "1"	not available
FSV1[9]	—	set to "0"	set to "1"	not available
FSV1[10]	—	set to "0"	set to "1"	not available
FSV1[11]	—	set to "0"	set to "1"	not available
FSV1[12]	—	set to "0"	set to "1"	not available
FSV1[13]	—	set to "0"	set to "1"	not available
FSV1[14]	—	set to "0"	set to "1"	not available
FSV1[15]	—	set to "0"	set to "1"	not available

Note : It is mandatory to always set the sector where the Flash Security Vectors FSV1 and FSV2 are located to write protected (here sector SA4). Otherwise it is possible to overwrite the Security Vector to a setting where it is possible to either read out the Flash content or manipulate data by writing.

See section "Flash access in CPU mode" for an overview about the sector organization of the Flash Memory.

MB91460S Series

5.3. Security Vector FSV2

The setting of the Flash Security Vector FSV2 bits [31:0] is responsible for the individual write protection of the 64 Kbytes sectors. It is only evaluated if write protection bit FSV1 [17] is set.

Explanation of the bits in the Flash Security Vector FSV2[31:0]

FSV1 bit	Sector	Enable Write Protection	Disable Write Protection	Comment
FSV2[0]	SA8	set to "0"	set to "1"	
FSV2[1]	SA9	set to "0"	set to "1"	
FSV2[2]	SA10	set to "0"	set to "1"	
FSV2[3]	SA11	set to "0"	set to "1"	
FSV2[4]	SA12	set to "0"	set to "1"	
FSV2[5]	SA13	set to "0"	set to "1"	
FSV2[6]	SA14	set to "0"	set to "1"	
FSV2[7]	SA15	set to "0"	set to "1"	
FSV2[8]	SA16	set to "0"	set to "1"	
FSV2[9]	SA17	set to "0"	set to "1"	
FSV2[10]	SA18	set to "0"	set to "1"	
FSV2[11]	SA19	set to "0"	set to "1"	
FSV2[12]	SA20	set to "0"	set to "1"	
FSV2[13]	SA21	set to "0"	set to "1"	
FSV2[14]	SA22	set to "0"	set to "1"	
FSV2[15]	SA23	set to "0"	set to "1"	
FSV2[31:16]	—	set to "0"	set to "1"	not available

Note : See section "Flash access in CPU mode" for an overview about the sector organization of the Flash Memory.

■ APIX® CONTROLLER

1. Overview

The integrated APIX® controller provides 2 links. Link 0 can be configured as an APIX® link or an Automotive Interconnect (AIC) link. Link 1 only supports AIC link.

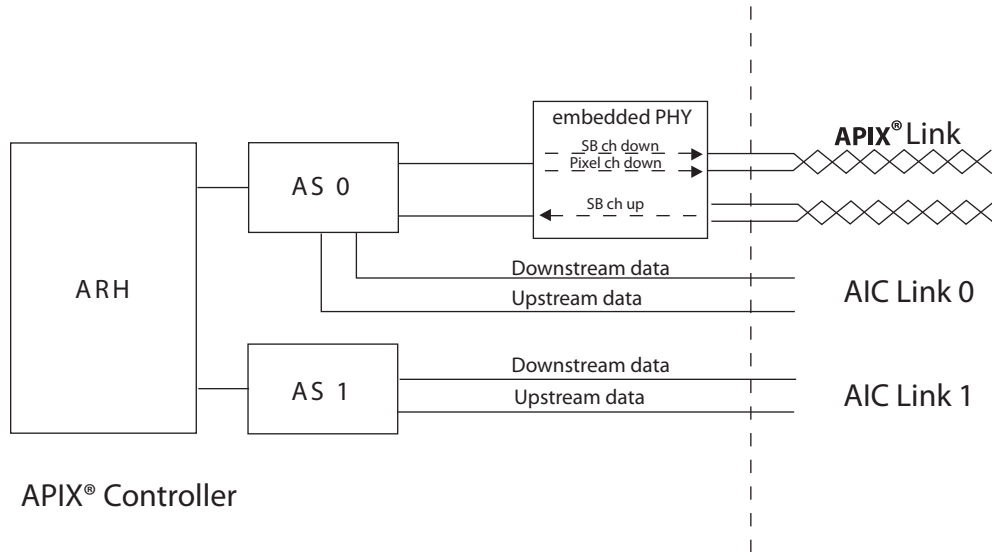

*Remark: Link 1 can be used only if Link 0 is activated (CHCTRL: TXCFG = 0)

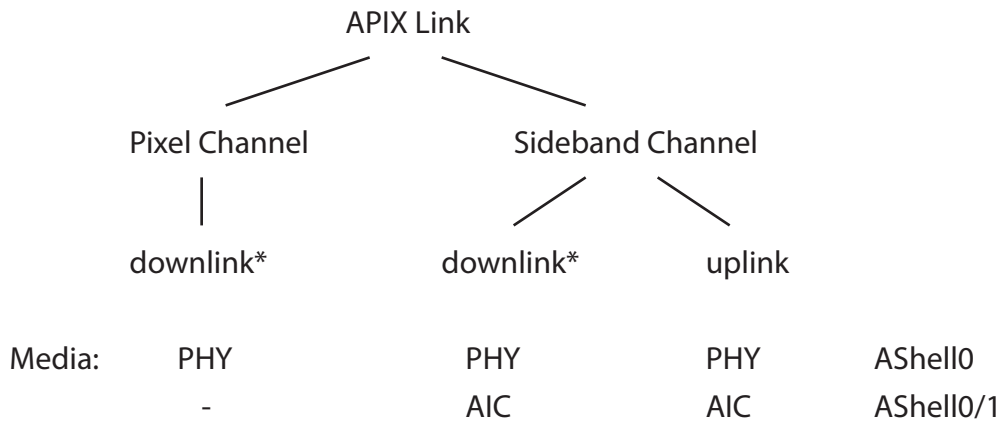

*Remark: MB91460S series provides either downlink over Pixelchannel or over Sidebandchannel

MB91460S Series

2. Automotive Remote Handler

The Automotive Remote Handler provides an Interface to the APIX® controller.

2.1. Register Description

2.1.1. General Control

- RHCTRL: Address 07200h

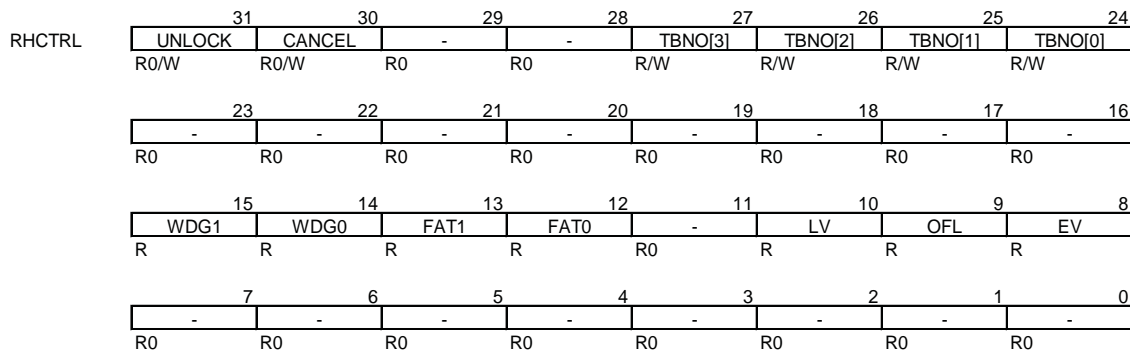

UNLOCK	0(def)	Transaction on buffer TBNO is requested
	1	Request unlock on waiting buffer TBNO
		Caution: Requested data gets lost or data is being received after using this buffer with same IDX
CANCEL	0(def)	Transaction on buffer TBNO is requested
	1	Request cancel on pending buffer TBNO
TBNO[3:0]	0-15	Writing starts transaction on buffer number TBNO
WDG1		readonly flag of enabled and selected CHWDG1.WDTXIRQx or enabled and selected CHWDG1.WDRXIRQx
WDG0		readonly flag of enabled and selected CHWDG0.WDTXIRQx or enabled and selected CHWDG0.WDRXIRQx
FAT0		readonly flag of enabled CHCTRL0.FATIRQ
FAT1		readonly flag of enabled CHCTRL1.FATIRQ
LV		readonly flag of enabled EVCTRL.LVIRQ
EV		readonly flag of enabled EVCTRL.EVIRQ
OFL		readonly flag of enabled EVCTRL.OFLIRQ

2.1.2. Channel Control and Status

- CHCTRL0 (Link 0): Address 07208h
- CHCTRL1 (Link 1): Address 07214h

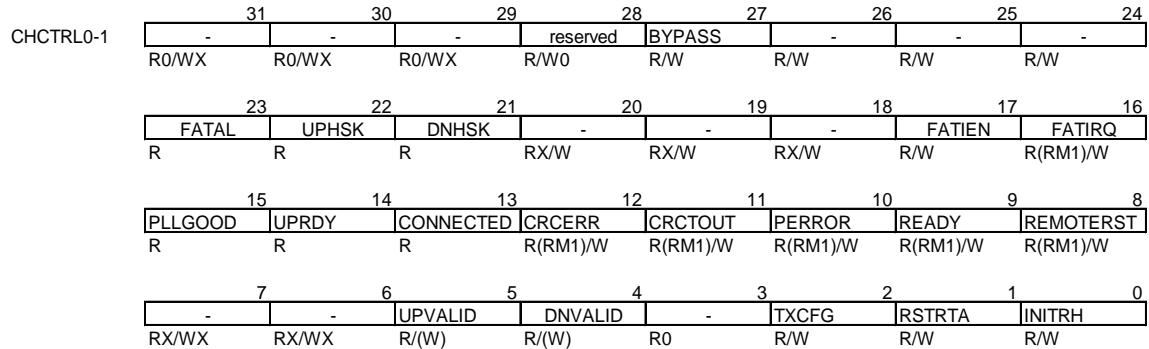

Bit28 reserved Bit
Always write 0 to this bit. The read value is the value written.

BYPASS: 0 Remote Handler active
1 Remote Handler inactive

In BYPASS mode Transaction Buffer 2 (for AShell 1) is used for downstream data (outbound) and Transaction Buffer 3 (for AShell 1) is used for upstream data (inbound).

Valid written data in Transaction Buffer 0/2 is delivered to AShell by setting DNVALID.

Valid received data in Transaction Buffer 1/3 from AShell is marked by setting UPVALID.

FATAL	1	indicates that AShell has encountered conditions where AShell can not continue to deliver and receive transactions. FATAL is only one CLKB cycle active.
UPHSK	1	indicates inbound handshake is performed
DNHSK	1	indicates outbound handshake is performed
FATIEN	0(def)	FATAL Interrupt disabled
	1	FATAL Interrupt enabled
FATIRQ	0(def)	FATAL Interrupt not active
	1	FATAL Interrupt active, triggered by FATAL

*Remark: On a RMW instruction a "1" is read; write "0" clears the interrupt; write "1" is ignored

*Remark: While Fatal Interrupt is active, the corresponding channel is deactivated and the triggered buffers are canceled.

UPRDY	1	indicates that upstream serial channel (APIX® PHY) is operational
CONNECTED	1	a connection to remote APIX® is established
CRCERR	1	indicates occurrence of CRC error in upstream data (inbound)

*Remark: On a RMW instruction a "1" is read; write "0" clears the flag; write "1" is ignored

CRCTOUT	1	indicates occurrence of CRC timeout in upstream data (inbound)
---------	---	--

*Remark: On a RMW instruction a "1" is read; write "0" clears the flag; write "1" is ignored

PERROR	1	indicates occurrence of a protocol error
--------	---	--

MB91460S Series

*Remark: On a RMW instruction a “1” is read; write “0” clears the flag; write “1” is ignored

READY 1 indicates that AShell is ready to accept outbound transactions
 REMOTERST 1 indicates a restart of remote AShell was performed

*Remark: On a RMW instruction a “1” is read; write “0” clears the flag; write “1” is ignored

UPVALID BYPASS==0 read only Read only status (ap_data_out_valid)
 BYPASS==1 0(def) Cleared by SW after successful reception (read) of upstream data
 1 Set by HW to mark upstream data as valid (ap_data_out_valid)
 DNVALID BYPASS==0 read only DNVALID is only operational in BYPASS mode (always read 0)
 BYPASS==1 0(def) Cleared by HW after successful transfer to AShell
 1 Set by SW to mark downstream data as valid (ap_data_in_valid)
 TXCFG 0 AShell and PHY running (write protection on APCFG registers)
 1(def) AShell and PHY configuration (possible to change APCFG registers)
 RSTRTA 0 AShell running Level
 1(def) AShell initialization
 INITRH 0 Remote Handler running Level
 1(def) Remote Handler initialization (no change of TB* and TF* registers)

*Remark: PENDING requests (set while INIT==1) will be started with INIT==0

- CHSTAT0 (Link 0): Address 0720Ch
- CHSTAT1 (Link 1): Address 07218h

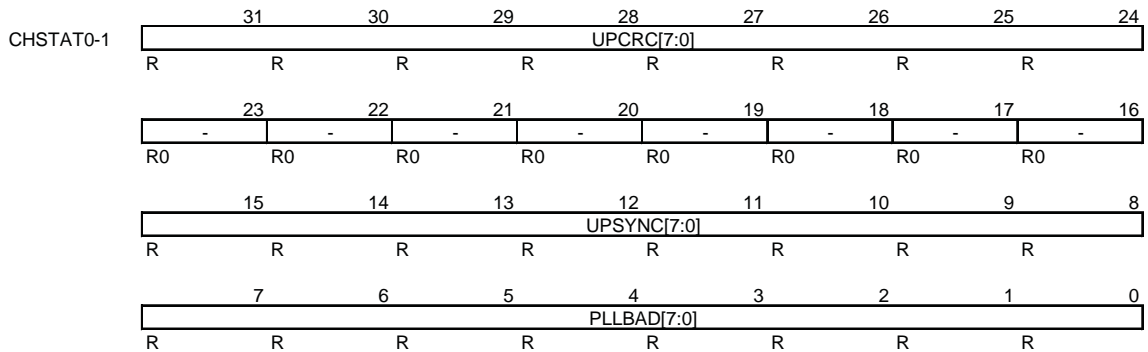

UP_CRC 0-255 Inbound CRC errors
 UP_SYNC 0-255 Synchronization losses
 PLL_BAD 0-255 PLL synchronization losses

2.1.3. Channel Watchdog

- CHWDG0 (Link 0): Address 07210h
- CHWDG1 (Link 1): Address 0721Ch

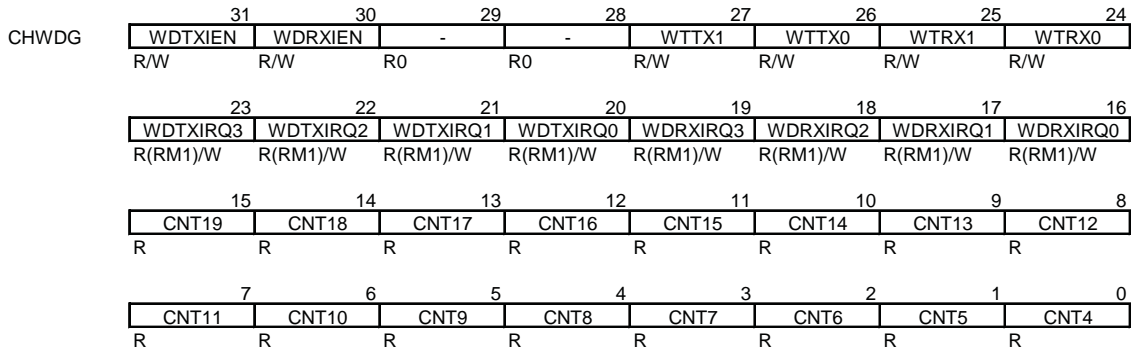

WDTXIEN	0(def)	Watchdog interrupt for TX is disabled
	1	Watchdog interrupt for TX is enabled
WDRXIEN	0(def)	Watchdog interrupt for RX is disabled
	1	Watchdog interrupt for RX is enabled
WTTX	0	select WDTXIRQ0
	1	select WDTXIRQ1
	2	select WDTXIRQ2
	3	select WDTXIRQ3
WTRX	0	select WDRXIRQ0
	1	select WDRXIRQ1
	2	select WDRXIRQ2
	3	select WDRXIRQ3
WDTXIRQ3	0(def)	interrupt for TX at 2^{19} is not active
	1	interrupt for TX at 2^{19} is active
WDTXIRQ2	0(def)	interrupt for TX at 2^{16} is not active
	1	interrupt for TX at 2^{16} is active
WDTXIRQ1	0(def)	interrupt for TX at 2^{14} is not active
	1	interrupt for TX at 2^{14} is active
WDTXIRQ0	0(def)	interrupt for TX at 2^{13} is not active
	1	interrupt for TX at 2^{13} is active
WDRXIRQ3	0(def)	interrupt for RX at 2^{19} is not active
	1	interrupt for RX at 2^{19} is active
WDRXIRQ2	0(def)	interrupt for RX at 2^{18} is not active
	1	interrupt for RX at 2^{18} is active
WDRXIRQ1	0(def)	interrupt for RX at 2^{17} is not active
	1	interrupt for RX at 2^{17} is active

MB91460S Series

WDRXIRQ0 0(def) interrupt for RX at 2¹⁶ is not active
 1 interrupt for RX at 2¹⁶ is active

*Remark: On a RMW instruction a “1” is read; write “0” clears the interrupt; write “1” is ignored

CNT upper 16Bit of the 20Bit watchdog freerun timer

2.1.4. Transaction Buffer Control

- TBCTRL00 (Transaction Buffer 00): Address 07220h
- TBCTRL01 (Transaction Buffer 01): Address 07222h
- TBCTRL02 (Transaction Buffer 02): Address 07224h
- TBCTRL03 (Transaction Buffer 03): Address 07226h
- TBCTRL04 (Transaction Buffer 04): Address 07228h
- TBCTRL05 (Transaction Buffer 05): Address 0722Ah
- TBCTRL06 (Transaction Buffer 06): Address 0722Ch
- TBCTRL07 (Transaction Buffer 07): Address 0723Eh
- TBCTRL08 (Transaction Buffer 08): Address 07230h
- TBCTRL09 (Transaction Buffer 09): Address 07232h
- TBCTRL10 (Transaction Buffer 10): Address 07234h
- TBCTRL11 (Transaction Buffer 11): Address 07236h
- TBCTRL12 (Transaction Buffer 12): Address 07238h
- TBCTRL13 (Transaction Buffer 13): Address 0723Ah
- TBCTRL14 (Transaction Buffer 14): Address 0723Ch
- TBCTRL15 (Transaction Buffer 15): Address 0723Eh

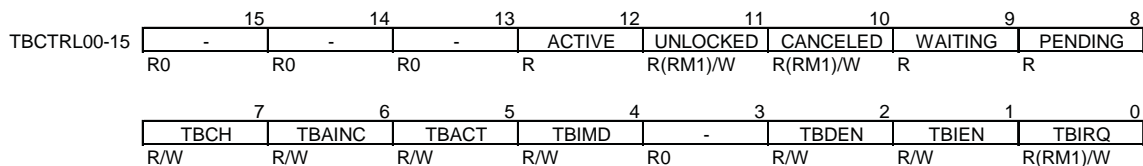

ACTIVE 0 No active data in Transaction Buffer
 1 Active data in Transaction Buffer (delivery to AShell requested)

UNLOCKED 0(def) No last action on this buffer
 1 Last action on this Transaction Buffer was UNLOCK

*Remark: On a RMW instruction a “1” is read; write “0” clears the register write “1” is ignored

CANCELED 0(def) No last action on this buffer
 1 Last action on this Transaction Buffer was a successful CANCEL

*Remark: On a RMW instruction a “1” is read; write “0” clears the register write “1” is ignored

WAITING 0 Not waiting for requested data
 1 Transaction Buffer waiting for requested data

*Remark: WAITING will be cleared at reception of requested data in buffer

PENDING 0 No pending data in Transaction Buffer
 1 Pending data in Transaction Buffer (not yet requested delivery to AShell)

TBCH 0(def) Transaction Buffer assigned to channel 0

	1	Transaction Buffer assigned to channel 1
TBAINC	0(def)	Transaction Buffer Address increment disabled
	1	Transaction Buffer Address increment enabled
		1. increments address after WR access to TBDATA and transmission of TF
		2. increments address after reception of requested TF and RD access to TBDATA, then autonomous transmission of next read request

*Remark: The address increment depends on the setting of TFCTRL.SIZE

TFCTRL.SIZE	00	increment by 1
TFCTRL.SIZE	01	increment by 2
TFCTRL.SIZE	10	increment by 4

*Remark: Address increment is only supported if TBACT = 1.

TBACT	0(def)	Transaction Buffer will be activated by WR access to TBNO
	1	Transaction Buffer will be activated by WR access to TBNO or TFDATA (RD and WR)
TBIMD	0(def)	Transaction Buffer Interrupt on TB idle (after transaction send)
	1	Transaction Buffer Interrupt on TB valid (after read request data reception)
TBIEN	0(def)	Transaction Buffer Interrupt disabled
	1	Transaction Buffer Interrupt enabled
TBDEN	0(def)	Transaction Buffer DMA disabled
	1	Transaction Buffer DMA enabled
TBIRQ	0	Transaction Buffer Interrupt not active
	1	Transaction Buffer Interrupt active

*Remark: On a RMW instruction a "1" is read; write "0" clears the interrupt; write "1" is ignored

*Remark: TBIRQ can/will be cleared by the following events:

1. Cleared by SW on write access to TBIRQ flag with data '0'
2. Cleared by HW if TBACT==1 and read or write access to TBDATA register (both CPU or DMA)
3. Cleared by HW if TBACT==1 and DMA asserts hardware clear signal IIOC

2.1.5. Transaction Buffer Interrupt

- TBIRQ: Address 07240h

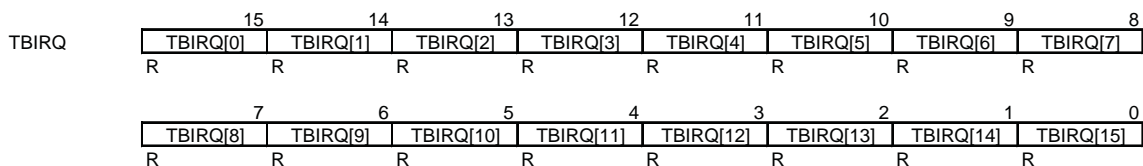

TBIRQ[15:0] Read only flags of enabled (TBIEN==1) TBCTRLxx.TBIRQ

2.1.6. Transaction Frame

- TFCTRL00 (Transaction Buffer 00): Address 07250h
- TFCTRL01 (Transaction Buffer 01): Address 07252h
- TFCTRL02 (Transaction Buffer 02): Address 07254h

MB91460S Series

- TFCTRL03 (Transaction Buffer 03): Address 07256h
- TFCTRL04 (Transaction Buffer 04): Address 07258h
- TFCTRL05 (Transaction Buffer 05): Address 0725Ah
- TFCTRL06 (Transaction Buffer 06): Address 0725Ch
- TFCTRL07 (Transaction Buffer 07): Address 0725Eh
- TFCTRL08 (Transaction Buffer 08): Address 07260h
- TFCTRL09 (Transaction Buffer 09): Address 07262h
- TFCTRL10 (Transaction Buffer 10): Address 07264h
- TFCTRL11 (Transaction Buffer 11): Address 07266h
- TFCTRL12 (Transaction Buffer 12): Address 07268h
- TFCTRL13 (Transaction Buffer 13): Address 0726Ah
- TFCTRL14 (Transaction Buffer 14): Address 0726Ch
- TFCTRL15 (Transaction Buffer 15): Address 0726Eh

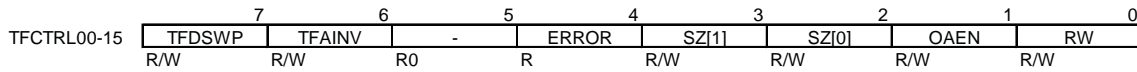

RW	0	Read
	1	Write
OAEN	0	Offset address disabled
	1	Offset address enabled
SZ[1:0]	00	Byte
	01	Halfword
	10	Word
	11	-
ERROR	0	Normal operation
	1	Remote Handler RX bus error occurred
TFAINV	0	Normal mode
	1	Address inversion

In address inversion mode the two least significant bits of the address are inverted

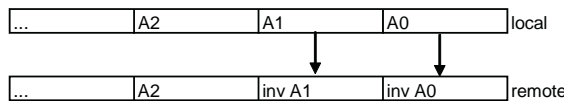

TFDSWP	0	Normal mode
	1	Byte swapping

In swapping mode depending on the configured size the following byte swapping of the data is performed

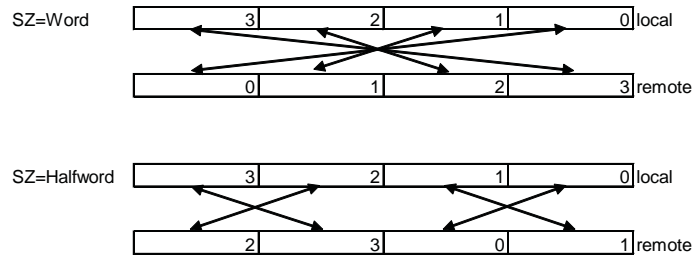

- TFIDX00 (Transaction Buffer 00): Address 07251h
- TFIDX01 (Transaction Buffer 01): Address 07253h
- TFIDX02 (Transaction Buffer 02): Address 07255h
- TFIDX03 (Transaction Buffer 03): Address 07257h
- TFIDX04 (Transaction Buffer 04): Address 07259h
- TFIDX05 (Transaction Buffer 05): Address 0725Bh
- TFIDX06 (Transaction Buffer 06): Address 0725Dh
- TFIDX07 (Transaction Buffer 07): Address 0725Fh
- TFIDX08 (Transaction Buffer 08): Address 07261h
- TFIDX09 (Transaction Buffer 09): Address 07263h
- TFIDX10 (Transaction Buffer 10): Address 07265h
- TFIDX11 (Transaction Buffer 11): Address 07267h
- TFIDX12 (Transaction Buffer 12): Address 07269h
- TFIDX13 (Transaction Buffer 13): Address 0726Bh
- TFIDX14 (Transaction Buffer 14): Address 0726Dh
- TFIDX15 (Transaction Buffer 15): Address 0726Fh

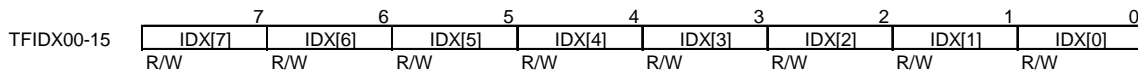

IDX[7:0] Any number between 0 and 255

*Remark: Index is used for read request. Received data from a read request will be stored in an active Transaction Buffer with matching index.

If there is no active Transaction Buffer with matching index (e.g. by using UNLOCK), the received data is discarded.

- TFADDR00 (Transaction Buffer 00): Address 07270h
- TFADDR01 (Transaction Buffer 01): Address 07274h
- TFADDR02 (Transaction Buffer 02): Address 07278h
- TFADDR03 (Transaction Buffer 03): Address 0727Ch
- TFADDR04 (Transaction Buffer 04): Address 07280h
- TFADDR05 (Transaction Buffer 05): Address 07284h
- TFADDR06 (Transaction Buffer 06): Address 07288h
- TFADDR07 (Transaction Buffer 07): Address 0728Ch
- TFADDR08 (Transaction Buffer 08): Address 07290h
- TFADDR09 (Transaction Buffer 09): Address 07294h
- TFADDR10 (Transaction Buffer 10): Address 07298h
- TFADDR11 (Transaction Buffer 11): Address 0729Ch

MB91460S Series

- TFADDR12 (Transaction Buffer 12): Address 072A0h
- TFADDR13 (Transaction Buffer 13): Address 072A4h
- TFADDR14 (Transaction Buffer 14): Address 072A8h
- TFADDR15 (Transaction Buffer 15): Address 072ACh

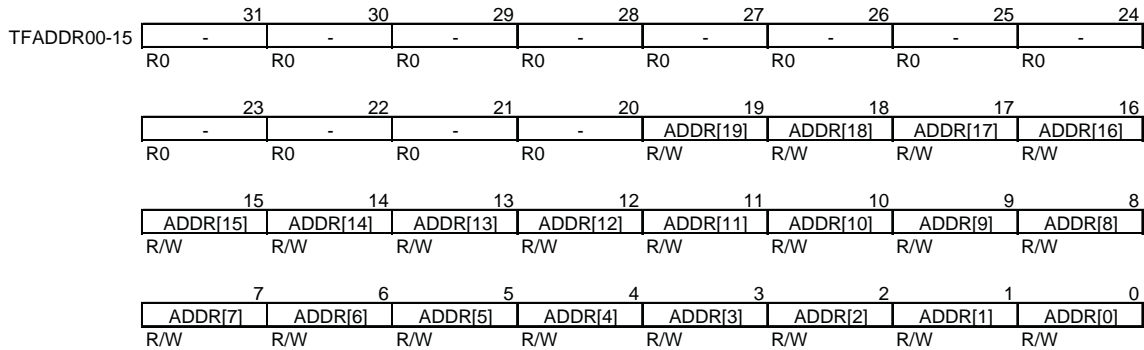

ADDR[19:0] Address in remote system

- TFDATA00 (Transaction Buffer 00): Address 072B0h
- TFDATA01 (Transaction Buffer 01): Address 072B4h
- TFDATA02 (Transaction Buffer 02): Address 072B8h
- TFDATA03 (Transaction Buffer 03): Address 072BCh
- TFDATA04 (Transaction Buffer 04): Address 072C0h
- TFDATA05 (Transaction Buffer 05): Address 072C4h
- TFDATA06 (Transaction Buffer 06): Address 072C8h
- TFDATA07 (Transaction Buffer 07): Address 072CCh
- TFDATA08 (Transaction Buffer 08): Address 072D0h
- TFDATA09 (Transaction Buffer 09): Address 072D4h
- TFDATA10 (Transaction Buffer 10): Address 072D8h
- TFDATA11 (Transaction Buffer 11): Address 072DCh
- TFDATA12 (Transaction Buffer 12): Address 072E0h
- TFDATA13 (Transaction Buffer 13): Address 072E4h
- TFDATA14 (Transaction Buffer 14): Address 072E8h
- TFDATA15 (Transaction Buffer 15): Address 072ECh

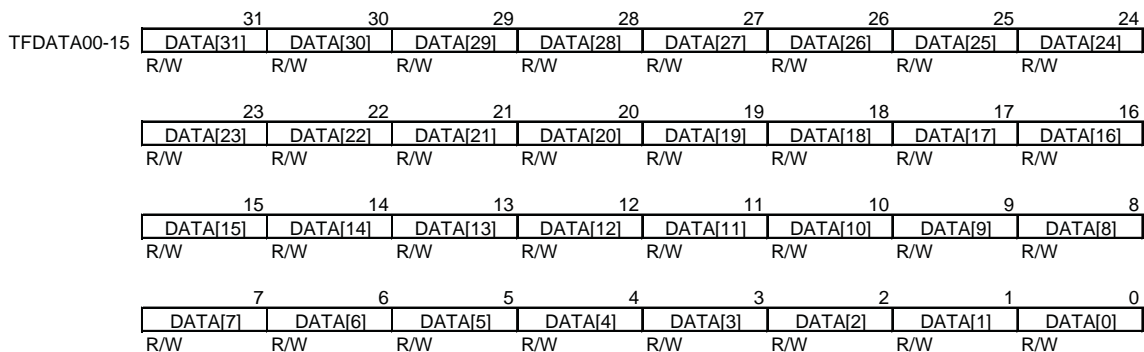

DATA[31:0] Payload data

2.1.7. Event Control

- EVCTRL: Address 072F0h

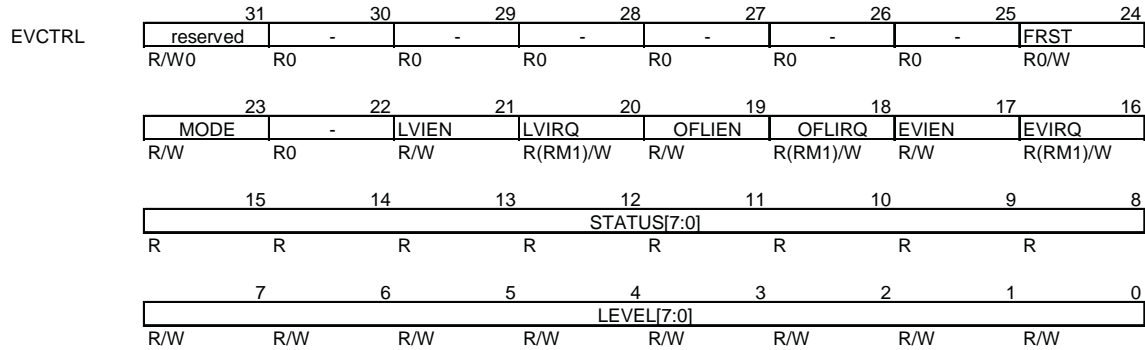

Bit31 reserved Bit
Always write 0 to this bit. The read value is the value written.

FRST 0(def) FIFO in normal operation
1 FIFO pointers are reset pulse (set to 0 after 1 cycle)

MODE 0 (def) level mode On full FIFO new Events are discarded
1 ring mode

LVIEN 0(def) Level Interrupt disabled
1 Level Interrupt enabled

LVIRQ 0(def) Level Interrupt not active
1 Level Interrupt active (if STATUS \geq LEVEL)

*Remark: On a RMW instruction a "1" is read; write "0" clears the interrupt; write "1" is ignored

OFLIEN 0(def) Event Buffer Overflow Interrupt disabled
1 Event Buffer Overflow Interrupt enabled

OFLIRQ 0(def) Event Buffer Overflow Interrupt not active
1 Event Buffer Overflow Interrupt active

*Remark: On a RMW instruction a "1" is read; write "0" clears the interrupt; write "1" is ignored

EVIEN 0(def) Event Buffer Interrupt disabled
1 Event Buffer Interrupt enabled

EVIRQ 0(def) Event Buffer Interrupt not active
1 Event Buffer Interrupt active

*Remark: On a RMW instruction a "1" is read; write "0" clears the interrupt; write "1" is ignored

Set by hardware, reset by software

STATUS[7:0] 0-128 Current FIFO filling status read only

LEVEL[7:0] 0-128 FIFO interrupt level (128 default)

MB91460S Series

2.1.8. Eventbuffer

- EVBUF0: Address 072F8h
- EVBUF1: Address 072FCh

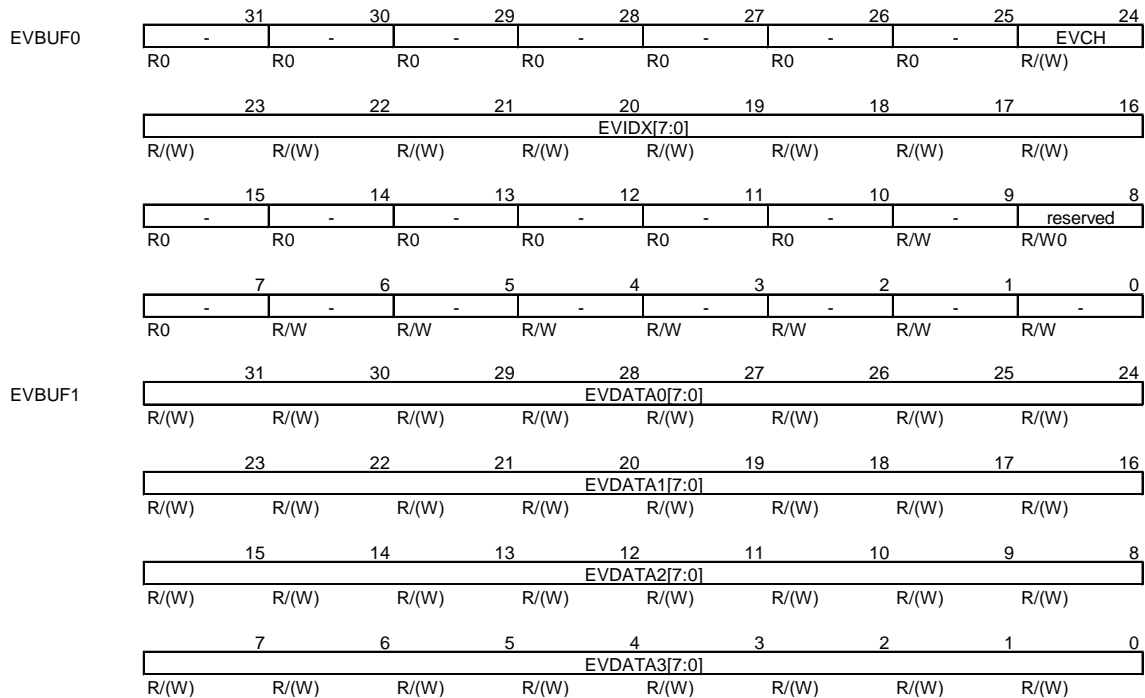

- EVCH Holds channel number from Remote Handler RX event
- EVIDX[7:0] 0-255 Holds index number from Remote Handler RX event
- Bit8 reserved Bit
- Always write 0 to this bit. The read value is the value written.
- EVDATA0-3 4 bytes of payload data

*Remark: It is recommended to read first EVBUF0 and

A read access to EVBUF0 triggers a retrieve of the current event message from the event buffer fifo and returns the channel number and event index.

A read access to EVBUF1 returns the data part of the a event message

2.1.9. Apix® configuration

- APCFG0x (Link 0)
- APCFG1x (Link 1)

APCFG00/APCFG10	31	30	29	28	27	26	25	24
	config byte 1							
	R/W	R/W	R/W	R/W	R/W	R/W	R/W	R/W
	0	0	0	0	0	0	0	0
APCFG01/APCFG11	31	30	29	28	27	26	25	24
	config byte 5							
	R/W	R/W	R/W	R/W	R/W	R/W	R/W	R/W
	1	1	1	1	0	0	0	0
APCFG02/APCFG12	31	30	29	28	27	26	25	24
	config byte 9							
	R/W	R/W	R/W	R/W	R/W	R/W	R/W	R/W
	0	0	0	0	0	0	1	0
APCFG03/APCFG13	31	30	29	28	27	26	25	24
	config byte shell 1							
	R/W	R/W	R/W	R/W	R/W	R/W	R/W	R/W
	0	0	1	0	0	1	1	0
APCFG00/APCFG10	23	22	21	20	19	18	17	16
	config byte 2							
	R/W	R/W	R/W	R/W	R/W	R/W	R/W	R/W
	0	0	1	0	0	0	0	0
APCFG01/APCFG11	23	22	21	20	19	18	17	16
	config byte 6							
	R/W	R/W	R/W	R/W	R/W	R/W	R/W	R/W
	0	0	0	0	0	0	0	0
APCFG02/APCFG12	23	22	21	20	19	18	17	16
	config byte 10							
	R/W	R/W	R/W	R/W	R/W	R/W	R/W	R/W
	0	0	0	0	0	0	1	0
APCFG03/APCFG13	23	22	21	20	19	18	17	16
	config byte shell 2							
	R/W	R/W	R/W	R/W	R/W	R/W	R/W	R/W
	1	0	1	0	0	0/1	0	0
APCFG00/APCFG10	15	14	13	12	11	10	9	8
	config byte 3							
	R/W	R/W	R/W	R/W	R/W	R/W	R/W	R/W
	0	0	0	0	0	0	0	0
APCFG01/APCFG11	15	14	13	12	11	10	9	8
	config byte 7							
	R/W	R/W	R/W	R/W	R/W	R/W	R/W	R/W
	0	0	0	0	0	0	0	0
APCFG02/APCFG12	15	14	13	12	11	10	9	8
	config byte 11							
	R/W	R/W	R/W	R/W	R/W	R/W	R/W	R/W
	0	1	0	0	0	0	0	0
APCFG03/APCFG13	15	14	13	12	11	10	9	8
	config byte shell 3							
	R/W	R/W	R/W	R/W	R/W	R/W	R/W	R/W
	1	0	0	1	1	0	1	0
APCFG00/APCFG10	7	6	5	4	3	2	1	0
	config byte 4							
	R/W	R/W	R/W	R/W	R/W	R/W	R/W	R/W
	1	0	0	1	0	0	0	0
APCFG01/APCFG11	7	6	5	4	3	2	1	0
	config byte 8							
	R/W	R/W	R/W	R/W	R/W	R/W	R/W	R/W
	0	1	0	0	1	0	0	0
APCFG02/APCFG12	7	6	5	4	3	2	1	0
	config byte shell 4							
	R/W	R/W	R/W	R/W	R/W	R/W	R/W	R/W
	0	0	-	-	-	-	-	-

AShell and PHY configuration.

MB91460S Series

2.1.10. Module ID

- MODULEID: Address 07320h
MODULEID[31:0]: Version of the APIX® controller

3. APIX^{1/4}® PHY Configuration

3.1. Powerdown

Configuration Vector:		APCFG 00
Bit	Default	Description
31	0	global power down (upstream, downstream and PLL) 1: power down 0: power up
29	0	power down serializer and output driver (diff amp) 1: power down 0: power up
28	0	power down upstream path 1: power down 0: power up

3.2. Nominal Current

Configuration Vector:		APCFG 01
Bit	Default	Description
19	0	nominal current setting (64 steps) 000000: min (0 mA - power down output driver) 111111: max
18	0	
17	0	
16	0	
15	0	
14	0	

3.3. Pre-emphasis

Configuration Vector:		APCFG 00
Bit	Default	Description
26	0	pre-emphasis configuration: reduce output current (pre-emphasis) after N equal serial bits (N = 0..7)
25	0	
24	0	

Configuration Vector:		APCFG 01
Bit	Default	Description
13	0	pre-emphasis current setting (64 steps) 000000: min (0 mA - power down output driver) 111111: max
12	0	
11	0	
10	0	
9	0	
8	0	

3.4. Sampling Offset

Configuration Vector:		APCFG 00
Bit	Default	Description
11	0	upstream sampling point configuration 0000: optimum sampling point when operating in 62.50 Mbit/s mode 0010: optimum sampling point when operating in 41.67 Mbit/s or 31.25 Mbit/s mode 0100: optimum sampling point when operating in 20.83 Mbit/s mode
10	0	
9	0	
8	0	

3.5. Charge Pump Control

Configuration Vector:		APCFG 01
Bit	Default	Description
23	1	charge pump current control
22	0	
21	0	
20	0	

MB91460S Series

4. DMA transfer request

To request a DMA transfer by a Transaction Buffer, please configure the transfer request source in DMACAx as follows.

IS	EIS(DDNO)	RN	Function	Transfer stop request
10000	1010	160	APIX® Transaction Buffer 0	available
10001	1010	161	APIX® Transaction Buffer 1	available
10010	1010	162	APIX® Transaction Buffer 2	available
10011	1010	163	APIX® Transaction Buffer 3	available
10100	1010	164	APIX® Transaction Buffer 4	available
10101	1010	165	APIX® Transaction Buffer 5	available
10110	1010	166	APIX® Transaction Buffer 6	available
10111	1010	167	APIX® Transaction Buffer 7	available
11000	1010	168	APIX® Transaction Buffer 8	available
11001	1010	169	APIX® Transaction Buffer 9	available
11010	1010	170	APIX® Transaction Buffer 10	available
11011	1010	171	APIX® Transaction Buffer 11	available
11100	1010	172	APIX® Transaction Buffer 12	available
11101	1010	173	APIX® Transaction Buffer 13	available
11110	1010	174	APIX® Transaction Buffer 14	available
11111	1010	175	APIX® Transaction Buffer 15	available

5. Automotive Interconnect Pins

The AIC Pins also serve as general ports.

Pin name	Pin function	I/O format	Pull-up Pull-down	Standby control	Setting required to use
RCK0	AIC uplink clock of Apix® link0	CMOS output and CMOS hysteresis, CMOS Automotive hysteresis, TTL input	Programmable	Provided	Set port function mode PFR28: Bit0 = 1, EPFR28: Bit0 = 1
RDA00	AIC uplink data of Apix® link0				Set port function mode PFR28: Bit1 = 1, EPFR28: Bit1 = 1
RDA01					Set port function mode PFR28: Bit2 = 1, EPFR28: Bit2 = 1
TDA00	AIC downlink data of Apix® link0				Set port function mode PFR28: Bit5 = 1, EPFR28: Bit5 = 1
TDA01					Set port function mode PFR28: Bit6 = 1, EPFR28: Bit6 = 1
TCLI0	AIC downlink clock of Apix® link0				Set port function mode PFR28: Bit7 = 1, EPFR28: Bit7 = 1
RCK1	AIC uplink clock of Apix® link1				Set port function mode PFR17: Bit0 = 1, EPFR17: Bit0 = 1
RDA10	AIC uplink data of Apix® link1				Set port function mode PFR17: Bit1 = 1, EPFR17: Bit1 = 1
RDA11					Set port function mode PFR17: Bit2 = 1, EPFR17: Bit2 = 1
TDA10	AIC downlink data of Apix® link1				Set port function mode PFR17: Bit5 = 1, EPFR17: Bit5 = 1
TDA11					Set port function mode PFR17: Bit6 = 1, EPFR17: Bit6 = 1
TCLI1	AIC downlink clock of Apix® link1				Set port function mode PFR17: Bit7 = 1, EPFR17: Bit7 = 1

MB91460S Series

6. USECASES

6.1. Communication over APIX® link

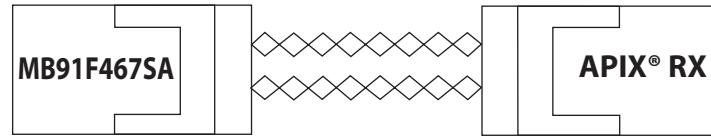

6.1.1. Downlink over Pixelchannel

Downlink over Pixelchannel is provided by default configuration. Please configure the PHY according to Chapter “APIX¼® PHY Configuration” on page 52

6.1.2. Downlink over Sidebandchannel

Register	Bit	Default	Value	Description
APCFG01	31	1	0	0: disable data mode / enable pixel stream mode 1: enable data mode / disable pixel stream mode

6.2. Communication over Automotive Interconnect to external AShell

6.2.1. 1Bit Datawidth

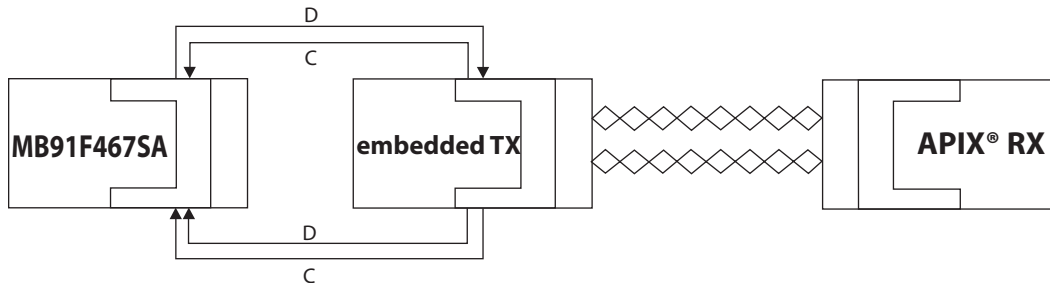

Register	Bit	Default	Value	Description
APCFGn1	31	1	0	0: disable data mode / enable pixel stream mode 1: enable data mode / disable pixel stream mode
APCFGn1	29	1	0	1: enable core clock of APIX® PHY 0: disable
APCFGn3	23	1	0	1: sbup_data[1:0] 0: sbup_data[0]
APCFGn3	21	1	0	1: sbdown_data[1:0] 0: sbdown_data[0]
APCFGn3	18	0	1	AShell: connect internal Ashell to external APIX® PHY through GPIO interface 1: enable 0: disable

6.2.2. 2Bit Datawidth

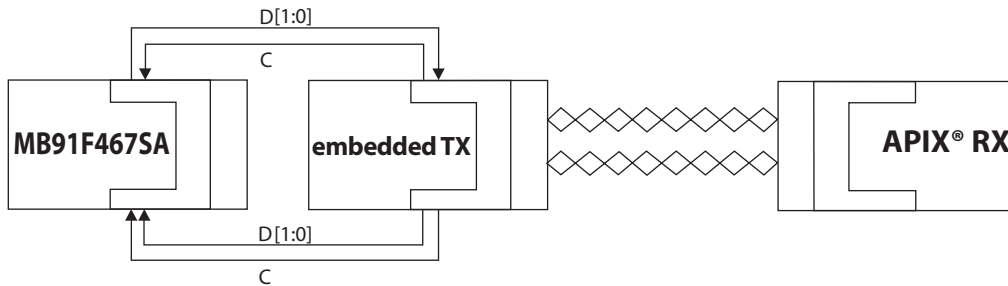

Register	Bit	Default	Value	Description
APCFGn1	31	1	0	0: disable data mode / enable pixel stream mode 1: enable data mode / disable pixel stream mode
APCFGn1	29	1	0	1: enable core clock of APIX® PHY 0: disable
APCFGn3	18	0	1	AShell: connect internal Ashell to external APIX® PHY through GPIO interface 1: enable 0: disable

6.3. Communication over Automotive Interconnect to external PHY

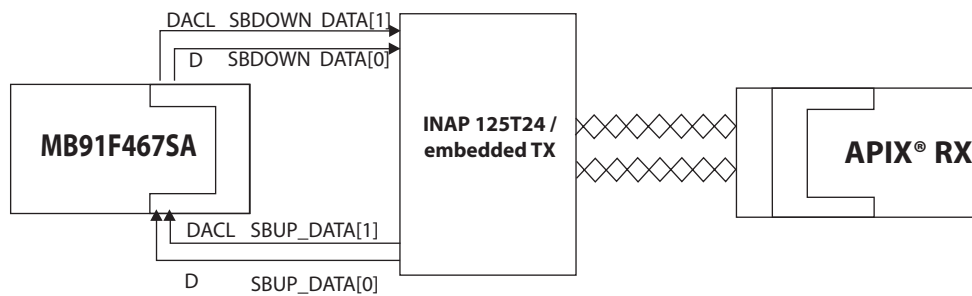

MB91460S Series

Register	Bit	Default	Value	Description
APCFGn1	31	1	0	0: disable data mode / enable pixel stream mode 1: enable data mode / disable pixel stream mode
APCFGn1	29	1	0	1: enable core clock of APIX® PHY 0: disable
APCFGn3	22	0	1	AShell: validate sbup_data with 1: sbup_data[1] 0: sbup_valid
APCFGn3	20	0	1	AShell: generate sbdown clock and transmit as sbdown_data[1] 11: disable 10: with use of internal counter (asynchronous to core_clk of APIX® PHY) 01: with use of sbdown_trigger (synchronous to core_clk of APIX® PHY) 00: disable
APCFGn3	19	0	0	
APCFGn3	18	0	1	AShell: connect internal Ashell to external APIX® PHY through GPIO interface 1: enable 0: disable
APCFGn3	2	0	t.b.d.	AShell: configures cycle time of sbdown clock (multiples of Ashell core clock) when sbdown_data are asynchronous (sbdown_data[1] is used as sbdown clock) or cfg_spi_over_sb is enabled 0x0B: recommended minimum (no low bandwidth mode, AShell and APIX® PHY operate at same core clock frequency) 0x14: recommended minimum (low bandwidth mode 2, AShell and APIX® PHY operate at 62.5 MHz) 0x26: recommended minimum (low bandwidth mode 1, AShell and APIX® PHY operate at 62.5 MHz)
	1	0		
	0	0		
	30	0		
	29	1		
	28	0		
	27	0		
	26	1		
	25	1		
	24	0		

6.4. Caution

Up to now only the usecases “Downlink over Pixelchannel” on page 56 and “Communication over Automotive Interconnect to external PHY” on page 57 are guaranteed.

■ MEMORY SPACE

The FR family has 4 Gbytes of logical address space (2^{32} addresses) available to the CPU by linear access.

- Direct addressing area

The following address space area is used for I/O.

This area is called direct addressing area, and the address of an operand can be specified directly in an instruction.

The size of directly addressable area depends on the length of the data being accessed as shown below.

Byte data access : 000_H to 0FF_H

Half word access : 000_H to 1FF_H

Word data access : 000_H to 3FF_H

MB91460S Series

■ MEMORY MAPS

1. MB91F467SA

MB91F467SA

00000000h	I/O (direct addressing area)
00000400h	I/O
00001000h	DMA
00002000h	
00004000h	Flash-Cache (8 KBytes)
00006000h	
00007000h	Flash memory control
00008000h	
0000B000h	Boot ROM (4 Kbytes)
0000C000h	CAN
0000D000h	
00028000h	D-RAM (0 wait, 32 Kbytes)
00030000h	ID-RAM (32 Kbytes)
00038000h	
00040000h	Flash memory (1088 Kbytes)
00150000h	
00180000h	External bus area
00500000h	External data bus
FFFFFFFh	

Note: Access prohibited areas

■ I/O MAP

1. MB91F467SA

Address	Register				Block
	+ 0	+ 1	+ 2	+ 3	
000000 _H	PDR0 [R/W] XXXXXXXX	PDR1 [R/W] XXXXXXXX	PDR2 [R/W] XXXXXXXX	PDR3 [R/W] XXXXXXXX	T-unit port data register

Read/write attribute

Register initial value after reset

Register name (column 1 register at address 4n, column 2 register at address 4n + 1...)

Leftmost register address (for word access, the register in column 1 becomes the MSB side of the data.)

Note : Initial values of register bits are represented as follows:

“ 1 ” : Initial value “ 1 ”

“ 0 ” : Initial value “ 0 ”

“ X ” : Initial value “ undefined ”

“ - ” : No physical register at this location

Access is barred with an undefined data access attribute.

MB91460S Series

Address	Register				Block
	+ 0	+ 1	+ 2	+ 3	
000000 _H	PDR00 [R/W] XXXXXXXX	PDR01 [R/W] XXXXXXXX	Reserved		R-bus Port Data Register
000004 _H	Reserved	PDR05 [R/W] XXXXXXXX	PDR06 [R/W] XXXXXXXX	PDR07 [R/W] XXXXXXXX	
000008 _H	PDR08 [R/W] X - - X - - XX	PDR09 [R/W] - - - - XXXX	PDR10 [R/W] - - - - X - XX	Reserved	
00000C _H	Reserved		PDR14 [R/W] XXXXXXXX	PDR15 [R/W] - - - - XXXX	
000010 _H	PDR16 [R/W] XXXXXXXX	PDR17 [R/W] XXXXXXXX	PDR18 [R/W] - XXX - XXX	PDR19 [R/W] - XXX - XXX	
000014 _H	PDR20 [R/W] - XXX - XXX	Reserved	PDR22 [R/W] XXXX - X - X	PDR23 [R/W] - X - XXXXX	
000018 _H	PDR24 [R/W] XXXXXXXX	Reserved			
00001C _H	PDR28 [R/W] XXXXXXXX	PDR29 [R/W] XXXXXXXX	Reserved		
000024 _H to 00002C _H	Reserved				
000030 _H	EIRR0 [R/W] XXXXXXXX	ENIR0 [R/W] 00000000	ELVR0 [R/W] 00000000 00000000		External interrupt (INT 0 to INT 7)
000034 _H	EIRR1 [R/W] XXXXXXXX	ENIR1 [R/W] 00000000	ELVR1 [R/W] 00000000 00000000		External interrupt (INT 8 to INT 15)
000038 _H	DICR [R/W] - - - - - 0	HRCL [R/W] 0 - - 11111	RBSYNC*1		Delay Interrupt
00003C _H to 00004C _H	Reserved				
000050 _H	SCR02 [R/W, W] 00000000	SMR02 [R/W, W] 00000000	SSR02 [R/W, R] 00001000	RDR02/TDR02 [R/W] 00000000	LIN-USART 2
000054 _H	ESCR02 [R/W] 00000X00	ECCR02 [R/W, R, W] -00000XX	Reserved		
000058 _H	SCR03 [R/W, W] 00000000	SMR03 [R/W, W] 00000000	SSR03 [R/W, R] 00001000	RDR03/TDR03 [R/W] 00000000	LIN-USART 3
00005C _H	ESCR03 [R/W] 00000X00	ECCR03 [R/W, R, W] -00000XX	Reserved		

(Continued)

MB91460S Series

Address	Register				Block
	+ 0	+ 1	+ 2	+ 3	
000060 _H	SCR04 [R/W, W] 00000000	SMR04 [R/W, W] 00000000	SSR04 [R/W, R] 00001000	RDR04/TDR04 [R/W] 00000000	LIN-USART 4 with FIFO
000064 _H	ESCR04 [R/W] 00000X00	ECCR04 [R/W, R, W] -00000XX	FSR04 [R] - - - 00000	FCR04 [R/W] 0001 - 000	
000068 _H	SCR05 [R/W, W] 00000000	SMR05 [R/W, W] 00000000	SSR05 [R/W, R] 00001000	RDR05/TDR05 [R/W] 00000000	LIN-USART 5 with FIFO
00006C _H	ESCR05 [R/W] 00000X00	ECCR05 [R/W, R, W] -00000XX	FSR05 [R] - - - 00000	FCR05 [R/W] 0001 - 000	
000070 _H	SCR06 [R/W, W] 00000000	SMR06 [R/W, W] 00000000	SSR06 [R/W, R] 00001000	RDR06/TDR06 [R/W] 00000000	LIN-USART 6 with FIFO
000074 _H	ESCR06 [R/W] 00000X00	ECCR06 [R/W, R, W] -00000XX	FSR06 [R] - - - 00000	FCR06 [R/W] 0001 - 000	
000078 _H	SCR07 [R/W, W] 00000000	SMR07 [R/W, W] 00000000	SSR07 [R/W, R] 00001000	RDR07/TDR07 [R/W] 00000000	LIN-USART 7 with FIFO
00007C _H	ESCR07 [R/W] 00000X00	ECCR07 [R/W, R, W] -00000XX	FSR07 [R] - - - 00000	FCR07 [R/W] 0001 - 000	
000080 _H	Reserved				
000084 _H	BGR102 [R/W] 00000000	BGR002 [R/W] 00000000	BGR103 [R/W] 00000000	BGR003 [R/W] 00000000	Baud rate Generator LIN-USART 2 to 7
000088 _H	BGR104 [R/W] 00000000	BGR004 [R/W] 00000000	BGR105 [R/W] 00000000	BGR005 [R/W] 00000000	
00008C _H	BGR106 [R/W] 00000000	BGR006 [R/W] 00000000	BGR107 [R/W] 00000000	BGR007 [R/W] 00000000	
000090 _H to 0000CC _H	Reserved				
0000D0 _H	IBCR0 [R/W] 00000000	IBSR0 [R] 00000000	ITBAH0 [R/W] - - - - - 00	ITBAL0 [R/W] 00000000	I ² C 0
0000D4 _H	ITMKH0 [R/W] 00 - - - - 11	ITMKL0 [R/W] 11111111	ISMK0 [R/W] 01111111	ISBA0 [R/W] - 0000000	
0000D8 _H	Reserved	IDAR0 [R/W] 00000000	ICCR0 [R/W] - 0011111	Reserved	

(Continued)

MB91460S Series

Address	Register				Block
	+ 0	+ 1	+ 2	+ 3	
0000DC _H	IBCR1 [R/W] 00000000	IBSR1 [R] 00000000	ITBAH1[R/W] -----00	ITBAL1 [R/W] 00000000	I ² C 1
0000E0 _H	ITMKH1 [R/W] 00----11	ITMKL1 [R/W] 11111111	ISMK1 [R/W] 01111111	ISBA1 [R/W] -0000000	
0000E4 _H	Reserved	IDAR1 [R/W] 00000000	ICCR1 [R/W] -0011111	Reserved	
0000E8 _H to 0000FC _H	Reserved				
000100 _H	GCN10 [R/W] 00110010 00010000		Reserved	GCN20 [R/W] ----0000	PPG Control 0 to 3
000104 _H	GCN11 [R/W] 00110010 00010000		Reserved	GCN21 [R/W] ----0000	PPG Control 4 to 7
000108 _H	GCN12 [R/W] 00110010 00010000		Reserved	GCN22 [R/W] ----0000	PPG Control 8 to 11
00010C _H	Reserved				
000110 _H	PTMR00 [R] 11111111 11111111		PCSR00 [W] XXXXXXXX XXXXXXXX		PPG 0
000114 _H	PDUT00 [W] XXXXXXXX XXXXXXXX		PCNH00 [R/W] 0000000 -	PCNL00 [R/W] 000000 - 0	
000118 _H	PTMR01 [R] 11111111 11111111		PCSR01 [W] XXXXXXXX XXXXXXXX		PPG 1
00011C _H	PDUT01 [W] XXXXXXXX XXXXXXXX		PCNH01 [R/W] 0000000 -	PCNL01 [R/W] 000000 - 0	
000120 _H	PTMR02 [R] 11111111 11111111		PCSR02 [W] XXXXXXXX XXXXXXXX		PPG 2
000124 _H	PDUT02 [W] XXXXXXXX XXXXXXXX		PCNH02 [R/W] 0000000 -	PCNL02 [R/W] 000000 - 0	
000128 _H	PTMR03 [R] 11111111 11111111		PCSR03 [W] XXXXXXXX XXXXXXXX		PPG 3
00012C _H	PDUT03 [W] XXXXXXXX XXXXXXXX		PCNH03 [R/W] 0000000 -	PCNL03 [R/W] 000000 - 0	
000130 _H	PTMR04 [R] 11111111 11111111		PCSR04 [W] XXXXXXXX XXXXXXXX		PPG 4
000134 _H	PDUT04 [W] XXXXXXXX XXXXXXXX		PCNH04 [R/W] 0000000 -	PCNL04 [R/W] 000000 - 0	
000138 _H	PTMR05 [R] 11111111 11111111		PCSR05 [W] XXXXXXXX XXXXXXXX		PPG 5
00013C _H	PDUT05 [W] XXXXXXXX XXXXXXXX		PCNH05 [R/W] 0000000 -	PCNL05 [R/W] 000000 - 0	

(Continued)

MB91460S Series

Address	Register				Block
	+ 0	+ 1	+ 2	+ 3	
000140H	PTMR06 [R] 11111111 11111111		PCSR06 [W] XXXXXXXX XXXXXXXX		PPG 6
000144H	PDUT06 [W] XXXXXXXX XXXXXXXX		PCNH06 [R/W] 0000000 -	PCNL06 [R/W] 000000 - 0	
000148H	PTMR07 [R] 11111111 11111111		PCSR07 [W] XXXXXXXX XXXXXXXX		PPG 7
00014CH	PDUT07 [W] XXXXXXXX XXXXXXXX		PCNH07 [R/W] 0000000 -	PCNL07 [R/W] 000000 - 0	
000150H	PTMR08 [R] 11111111 11111111		PCSR08 [W] XXXXXXXX XXXXXXXX		PPG 8
000154H	PDUT08 [W] XXXXXXXX XXXXXXXX		PCNH08 [R/W] 0000000 -	PCNL08 [R/W] 000000 - 0	
000158H	PTMR09 [R] 11111111 11111111		PCSR09 [W] XXXXXXXX XXXXXXXX		PPG 9
00015CH	PDUT09 [W] XXXXXXXX XXXXXXXX		PCNH09 [R/W] 0000000 -	PCNL09 [R/W] 000000 - 0	
000160H	PTMR10 [R] 11111111 11111111		PCSR10 [W] XXXXXXXX XXXXXXXX		PPG 10
000164H	PDUT10 [W] XXXXXXXX XXXXXXXX		PCNH10 [R/W] 0000000 -	PCNL10 [R/W] 000000 - 0	
000168H	PTMR11 [R] 11111111 11111111		PCSR11 [W] XXXXXXXX XXXXXXXX		PPG 11
00016CH	PDUT11 [W] XXXXXXXX XXXXXXXX		PCNH11 [R/W] 0000000 -	PCNL11 [R/W] 000000 - 0	
000170H	P0TMCSRH [R/W] - 0 - 000 - 0	P0TMCSR [R/W] - - - 00000	P1TMCSRH [R/W] - 0 - 000 - 0	P1TMCSR [R/W] - - - 00000	Pulse Frequency Modulator
000174H	P0TMRLR [W] XXXXXXXX XXXXXXXX		P0TMR [R] XXXXXXXX XXXXXXXX		
000178H	P1TMRLR [W] XXXXXXXX XXXXXXXX		P1TMR [R] XXXXXXXX XXXXXXXX		
00017CH	Reserved				
000180H	Reserved	ICS01 [R/W] 00000000	Reserved	ICS23 [R/W] 00000000	Input Capture 0 to 3
000184H	IPCP0 [R] XXXXXXXX XXXXXXXX		IPCP1 [R] XXXXXXXX XXXXXXXX		
000188H	IPCP2 [R] XXXXXXXX XXXXXXXX		IPCP3 [R] XXXXXXXX XXXXXXXX		

(Continued)

MB91460S Series

Address	Register				Block
	+ 0	+ 1	+ 2	+ 3	
00018CH	OCS01 [R/W] --- 0 -- 00 0000 -- 00		OCS23 [R/W] --- 0 -- 00 0000 -- 00		Output Compare 0 to 3
000190H	OCCP0 [R/W] XXXXXXXX XXXXXXXX		OCCP1 [R/W] XXXXXXXX XXXXXXXX		
000194H	OCCP2 [R/W] XXXXXXXX XXXXXXXX		OCCP3 [R/W] XXXXXXXX XXXXXXXX		
000198H	SGCRH [R/W] 0000 -- 00	SGCRL [R/W] -- 0 -- 000	SGFR [R/W, R] XXXXXXXX XXXXXXXX		Sound Generator
00019CH	SGAR [R/W] 00000000	Reserved	SGTR [R/W] XXXXXXXX	SGDR [R/W] XXXXXXXX	
0001A0H	ADERH [R/W] 00000000 00000000		ADERL [R/W] 00000000 00000000		A/D Converter
0001A4	ADCS1 [R/W] 00000000	ADCS0 [R/W] 00000000	ADCR1 [R] 000000XX	ADCR0 [R] XXXXXXXX	
0001A8H	ADCT1 [R/W] 00010000	ADCT0 [R/W] 00101100	ADSCH [R/W] --- 00000	ADECH [R/W] --- 00000	
0001ACH	Reserved	ACSR0 [R/W] - 11XXX00	Reserved		Alarm Comparator 0
0001B0H	TMRLR0 [W] XXXXXXXX XXXXXXXX		TMR0 [R] XXXXXXXX XXXXXXXX		Reload Timer 0 (PPG 0, PPG 1)
0001B4H	Reserved		TMCSRH0 [R/W] --- 00000	TMCSRL0 [R/W] 0 - 000000	
0001B8H	TMRLR1 [W] XXXXXXXX XXXXXXXX		TMR1 [R] XXXXXXXX XXXXXXXX		Reload Timer 1 (PPG 2, PPG 3)
0001BCH	Reserved		TMCSRH1 [R/W] --- 00000	TMCSRL1 [R/W] 0 - 000000	
0001C0H	TMRLR2 [W] XXXXXXXX XXXXXXXX		TMR2 [R] XXXXXXXX XXXXXXXX		Reload Timer 2 (PPG 4, PPG 5)
0001C4H	Reserved		TMCSRH2 [R/W] --- 00000	TMCSRL2 [R/W] 0 - 000000	
0001C8H	TMRLR3 [W] XXXXXXXX XXXXXXXX		TMR3 [R] XXXXXXXX XXXXXXXX		Reload Timer 3 (PPG 6, PPG 7)
0001CCH	Reserved		TMCSRH3 [R/W] --- 00000	TMCSRL3 [R/W] 0 - 000000	

(Continued)

MB91460S Series

Address	Register				Block
	+ 0	+ 1	+ 2	+ 3	
0001D0 _H	TMRLR4 [W] XXXXXXXX XXXXXXXX		TMR4 [R] XXXXXXXX XXXXXXXX		Reload Timer 4 (PPG 8, PPG 9)
0001D4 _H	Reserved		TMCSRH4 [R/W] --- 00000	TMCSRL4 [R/W] 0 - 000000	
0001D8 _H	TMRLR5 [W] XXXXXXXX XXXXXXXX		TMR5 [R] XXXXXXXX XXXXXXXX		Reload Timer 5 (PPG 10, PPG 11)
0001DC _H	Reserved		TMCSRH5 [R/W] --- 00000	TMCSRL5 [R/W] 0 - 000000	
0001E0 _H	TMRLR6 [W] XXXXXXXX XXXXXXXX		TMR6 [R] XXXXXXXX XXXXXXXX		Reload Timer 6 (PPG 12, PPG 13)
0001E4 _H	Reserved		TMCSRH6 [R/W] --- 00000	TMCSRL6 [R/W] 0 - 000000	
0001E8 _H	TMRLR7 [W] XXXXXXXX XXXXXXXX		TMR7 [R] XXXXXXXX XXXXXXXX		Reload Timer 7 (PPG 14, PPG 15) (A/D Converter)
0001EC _H	Reserved		TMCSRH7 [R/W] --- 00000	TMCSRL7 [R/W] 0 - 000000	
0001F0 _H	TCDT0 [R/W] XXXXXXXX XXXXXXXX		Reserved	TCCS0 [R/W] 00000000	Free Running Timer 0 (ICU 0, ICU 1)
0001F4 _H	TCDT1 [R/W] XXXXXXXX XXXXXXXX		Reserved	TCCS1 [R/W] 00000000	Free Running Timer 1 (ICU 2, ICU 3)
0001F8 _H	TCDT2 [R/W] XXXXXXXX XXXXXXXX		Reserved	TCCS2 [R/W] 00000000	Free Running Timer 2 (OCU 0, OCU 1)
0001FC _H	TCDT3 [R/W] XXXXXXXX XXXXXXXX		Reserved	TCCS3 [R/W] 00000000	Free Running Timer 3 (OCU 2, OCU 3)

(Continued)

MB91460S Series

Address	Register				Block
	+ 0	+ 1	+ 2	+ 3	
000200H	DMACA0 [R/W] 00000000 0000XXXX XXXXXXXX XXXXXXXX				DMAC
000204H	DMACB0 [R/W] 00000000 00000000 XXXXXXXX XXXXXXXX				
000208H	DMACA1 [R/W] 00000000 0000XXXX XXXXXXXX XXXXXXXX				
00020CH	DMACB1 [R/W] 00000000 00000000 XXXXXXXX XXXXXXXX				
000210H	DMACA2 [R/W] 00000000 0000XXXX XXXXXXXX XXXXXXXX				
000214H	DMACB2 [R/W] 00000000 00000000 XXXXXXXX XXXXXXXX				
000218H	DMACA3 [R/W] 00000000 0000XXXX XXXXXXXX XXXXXXXX				
00021CH	DMACB3 [R/W] 00000000 00000000 XXXXXXXX XXXXXXXX				
000220H	DMACA4 [R/W] 00000000 0000XXXX XXXXXXXX XXXXXXXX				
000224H	DMACB4 [R/W] 00000000 00000000 XXXXXXXX XXXXXXXX				
000228H to 00023CH	Reserved				
000240H	DMACR [R/W] 00 - - 0000	Reserved			
000244H to 0002CCH	Reserved				
0002D0H	Reserved	ICS045 [R/W] 00000000	Reserved	ICS67 [R/W] 00000000	Input Capture 4 to 7
0002D4H	IPCP4 [R] XXXXXXXX XXXXXXXX		IPCP5 [R] XXXXXXXX XXXXXXXX		
0002D8H	IPCP6 [R] XXXXXXXX XXXXXXXX		IPCP7 [R] XXXXXXXX XXXXXXXX		
0002DCH to 0002ECH	Reserved				
0002F0H	TCDT4 [R/W] XXXXXXXX XXXXXXXX		Reserved	TCCS4 [R/W] 00000000	Free Running Timer 4 (ICU 4, ICU 5)

(Continued)

MB91460S Series

Address	Register				Block
	+ 0	+ 1	+ 2	+ 3	
0002F4 _H	TCDT5 [R/W] XXXXXXXX XXXXXXXX		Reserved	TCCS5 [R/W] 00000000	Free Running Timer 5 (ICU 6, ICU 7)
0002F8 _H	TCDT6 [R/W] XXXXXXXX XXXXXXXX		Reserved	TCCS6 [R/W] 00000000	Free Running Timer 6
0002FC _H	TCDT7 [R/W] XXXXXXXX XXXXXXXX		Reserved	TCCS7 [R/W] 00000000	Free Running Timer 7
000300 _H	UDRC1 [W] 00000000	UDRC0 [W] 00000000	UDCR1 [R] 00000000	UDCR0 [R] 00000000	Up/Down Counter 0/1
000304 _H	UDCCH0 [R/W] 00000000	UDCCL0 [R/W] 00000000	Reserved	UDCS0 [R/W] 00000000	
000308 _H	UDCCH1 [R/W] 00000000	UDCCL1 [R/W] 00000000	Reserved	UDCS1 [R/W] 00000000	
00030C _H	Reserved				
000310 _H	UDRC3 [W] 00000000	UDRC2 [W] 00000000	UDCR3 [R] 00000000	UDCR2 [R] 00000000	Up/Down Counter 2/3
000314 _H	UDCCH2 [R/W] 00000000	UDCCL2 [R/W] 00000000	Reserved	UDCS2 [R/W] 00000000	
000318 _H	UDCCH3 [R/W] 00000000	UDCCL3 [R/W] 00000000	Reserved	UDCS3 [R/W] 00000000	
00031C _H	Reserved				
000320 _H	GCN13 [R/W] 00110010 00010000		Reserved	GCN23 [R/W] - - - - 0000	PPG Control 12 to 15
000324 _H to 00032C _H	Reserved				
000330 _H	PTMR12 [R] 11111111 11111111		PCSR12 [W] XXXXXXXX XXXXXXXX		PPG 12
000334 _H	PDUT12 [W] XXXXXXXX XXXXXXXX		PCNH12 [R/W] 0000000 -	PCNL12 [R/W] 000000 - 0	
000338 _H	PTMR13 [R] 11111111 11111111		PCSR13 [W] XXXXXXXX XXXXXXXX		PPG 13
00033C _H	PDUT13 [W] XXXXXXXX XXXXXXXX		PCNH13 [R/W] 0000000 -	PCNL13 [R/W] 000000 - 0	
000340 _H	PTMR14 [R] 11111111 11111111		PCSR14 [W] XXXXXXXX XXXXXXXX		PPG 14
000344 _H	PDUT14 [W] XXXXXXXX XXXXXXXX		PCNH14 [R/W] 0000000 -	PCNL14 [R/W] 000000 - 0	

(Continued)

MB91460S Series

Address	Register				Block
	+ 0	+ 1	+ 2	+ 3	
000348 _H	PTMR15 [R] 11111111 11111111		PCSR15 [W] XXXXXXXX XXXXXXXX		PPG 15
00034C _H	PDUT15 [W] XXXXXXXX XXXXXXXX		PCNH15 [R/W] 0000000 -	PCNL15 [R/W] 000000 - 0	
000350 _H to 000364 _H	Reserved				
000368 _H	IBCR2 [R/W] 00000000	IBSR2 [R] 00000000	ITBAH2 [R/W] ----- 00	ITBAL2 [R/W] 00000000	I ² C 2
00036C _H	ITMKH2 [R/W] 00 - - - - 11	ITMKL2 [R/W] 11111111	ISMK2 [R/W] 01111111	ISBA2 [R/W] - 0000000	
000370 _H	Reserved	IDAR2 [R/W] 00000000	ICCR2 [R/W] - 0011111	Reserved	
000374 _H to 00038C _H	Reserved				
000390 _H	ROMS [R] 11111111 00000000		Reserved		ROM Select Register
000394 _H to 0003EC _H	Reserved				
0003F0 _H	BSD0 [W] XXXXXXXX XXXXXXXX XXXXXXXX XXXXXXXX				Bit Search Module
0003F4 _H	BSD1 [R/W] XXXXXXXX XXXXXXXX XXXXXXXX XXXXXXXX				
0003F8 _H	BSDC [W] XXXXXXXX XXXXXXXX XXXXXXXX XXXXXXXX				
0003FC _H	BSRR [R] XXXXXXXX XXXXXXXX XXXXXXXX XXXXXXXX				
000400 _H to 00043C _H	Reserved				

(Continued)

MB91460S Series

Address	Register				Block
	+ 0	+ 1	+ 2	+ 3	
000440H	ICR00 [R/W] ---11111	ICR01 [R/W] ---11111	ICR02 [R/W] ---11111	ICR03 [R/W] ---11111	Interrupt Controller
000444H	ICR04 [R/W] ---11111	ICR05 [R/W] ---11111	ICR06 [R/W] ---11111	ICR07 [R/W] ---11111	
000448H	ICR08 [R/W] ---11111	ICR09 [R/W] ---11111	ICR10 [R/W] ---11111	ICR11 [R/W] ---11111	
00044CH	ICR12 [R/W] ---11111	ICR13 [R/W] ---11111	ICR14 [R/W] ---11111	ICR15 [R/W] ---11111	
000450H	ICR16 [R/W] ---11111	ICR17 [R/W] ---11111	ICR18 [R/W] ---11111	ICR19 [R/W] ---11111	
000454H	ICR20 [R/W] ---11111	ICR21 [R/W] ---11111	ICR22 [R/W] ---11111	ICR23 [R/W] ---11111	
000458H	ICR24 [R/W] ---11111	ICR25 [R/W] ---11111	ICR26 [R/W] ---11111	ICR27 [R/W] ---11111	
00045CH	ICR28 [R/W] ---11111	ICR29 [R/W] ---11111	ICR30 [R/W] ---11111	ICR31 [R/W] ---11111	
000460H	ICR32 [R/W] ---11111	ICR33 [R/W] ---11111	ICR34 [R/W] ---11111	ICR35 [R/W] ---11111	
000464H	ICR36 [R/W] ---11111	ICR37 [R/W] ---11111	ICR38 [R/W] ---11111	ICR39 [R/W] ---11111	
000468H	ICR40 [R/W] ---11111	ICR41 [R/W] ---11111	ICR42 [R/W] ---11111	ICR43 [R/W] ---11111	
00046CH	ICR44 [R/W] ---11111	ICR45 [R/W] ---11111	ICR46 [R/W] ---11111	ICR47 [R/W] ---11111	
000470H	ICR48 [R/W] ---11111	ICR49 [R/W] ---11111	ICR50 [R/W] ---11111	ICR51 [R/W] ---11111	
000474H	ICR52 [R/W] ---11111	ICR53 [R/W] ---11111	ICR54 [R/W] ---11111	ICR55 [R/W] ---11111	
000478H	ICR56 [R/W] ---11111	ICR57 [R/W] ---11111	ICR58 [R/W] ---11111	ICR59 [R/W] ---11111	
00047CH	ICR60 [R/W] ---11111	ICR61 [R/W] ---11111	ICR62 [R/W] ---11111	ICR63 [R/W] ---11111	
000480H	RSRR [R/W] 10000000	STCR [R/W] 00110011	TBCR [R/W] 00XXX - 00	CTBR [W] XXXXXXXXXX	Clock Control
000484H	CLKR [R/W] ---- 0000	WPR [W] XXXXXXXXXX	DIVR0 [R/W] 00000011	DIVR1 [R/W] 00000000	
000488H	Reserved				
00048CH	PLLDIVM [R/W] ---- 0000	PLLDIVN [R/W] -- 000000	PLLDIVG [R/W] ---- 0000	PLLDIVG [W] 00000000	PLL Interface
000490H	PLLCTRL [R/W] ---- 0000	Reserved			

(Continued)

MB91460S Series

Address	Register				Block
	+ 0	+ 1	+ 2	+ 3	
000494 _H	OSCC1 [R/W] ----- 010	OSCS1 [R/W] 00001111	OSCC2 [R/W] ----- 010	OSCS2 [R/W] 00001111	Main/Sub Oscillator Control
000498 _H	PORTEN [R/W] ----- 00	Reserved			Port Input Enable Control
00049C _H	Reserved				
0004A0 _H	Reserved	WT CER [R/W] ----- 00	WT CR [R/W] 00000000 000 - 00 - 0		Real Time Clock (Watch Timer)
0004A4 _H	Reserved	WT BR [R/W] --- XXXXX XXXXXXXX XXXXXXXX			
0004A8 _H	WT HR [R/W] --- 00000	WT MR [R/W] -- 000000	WT SR [R/W] -- 000000	Reserved	
0004AC _H	CSVTR [R/W] --- 00010	CSVCR [R/W] 00011100	CSCFG [R/W] 0X000000	CMCFG [R/W] 00000000	Clock- Supervisor / Selector / Monitor
0004B0 _H	CUCR [R/W] ----- 0 -- 00		CUTD [R/W] 10000000 00000000		Calibration of Sub Clock
0004B4 _H	CUTR1 [R] ----- 00000000		CUTR2 [R] 00000000 00000000		
0004B8 _H	CMPR [R/W] -- 000010 11111101		Reserved	CMCR [R/W] - 001 -- 00	Clock Modulator
0004BC _H	CMT1 [R/W] 00000000 1 --- 0000		CMT2 [R/W] -- 000000 -- 000000		
0004C0 _H	CANPRE [R/W] -- 000000	CANCKD [R/W] ----- 00*3	Reserved		CAN Clock Control
0004C4 _H	LVSEL [R/W] 00000111	LVDET [R/W] 0000 0 - 00	HWWD E [R/W] ----- 00	HWWD [R/W, W] 00011000	Low Voltage Detection/ Hardware Watchdog
0004C8 _H	OSCRH [R/W] 000 -- 001	OSCRL [R/W] ----- 000	WPCR H [R/W] 00 --- 000	WPCR L [R/W] ----- 00	Main-/Sub-Oscillation Stabilization Timer
0004CC _H	OSCCR [R/W] ----- 0	Reserved	REGSEL [R/W] -- 000100	REGCTR [R/W] --- 0 -- 00	Main- Oscillation Standby Control Main-/Subregulator Control
0004D0 _H to 00063C _H	Reserved				

(Continued)

MB91460S Series

Address	Register				Block
	+ 0	+ 1	+ 2	+ 3	
000640 _H	ASR0 [R/W] 00000000 00000000		ACR0 [R/W] 1111**00 00100000*4		External Bus
000644 _H	ASR1 [R/W] XXXXXXXX XXXXXXXX		ACR1 [R/W] XXXXXXXX XXXXXXXX		
000648 _H	ASR2 [R/W] XXXXXXXX XXXXXXXX		ACR2 [R/W] XXXXXXXX XXXXXXXX		
00064C _H	ASR3 [R/W] XXXXXXXX XXXXXXXX		ACR3 [R/W] XXXXXXXX XXXXXXXX		
000650 _H	ASR4 [R/W] XXXXXXXX XXXXXXXX		ACR4 [R/W] XXXXXXXX XXXXXXXX		
000654 _H	ASR5 [R/W] XXXXXXXX XXXXXXXX		ACR5 [R/W] XXXXXXXX XXXXXXXX		
000658 _H	ASR6 [R/W] XXXXXXXX XXXXXXXX		ACR6 [R/W] XXXXXXXX XXXXXXXX		
00065C _H	ASR7 [R/W] XXXXXXXX XXXXXXXX		ACR7 [R/W] XXXXXXXX XXXXXXXX		
000660 _H	AWR0 [R/W] 01001111 11111011		AWR1 [R/W] XXXXXXXX XXXXXXXX		
000664 _H	AWR2 [R/W] XXXXXXXX XXXXXXXX		AWR3 [R/W] XXXXXXXX XXXXXXXX		
000668 _H	AWR4 [R/W] XXXXXXXX XXXXXXXX		AWR5 [R/W] XXXXXXXX XXXXXXXX		
00066C _H	AWR6 [R/W] XXXXXXXX XXXXXXXX		AWR7 [R/W] XXXXXXXX XXXXXXXX		
000670 _H	MCRA [R/W] XXXXXXXX	MCRB [R/W] XXXXXXXX	Reserved		
000674 _H	Reserved				
000678 _H	IORW0 [R/W] XXXXXXXX	IORW1 [R/W] XXXXXXXX	IORW2 [R/W] XXXXXXXX	Reserved	
00067C _H	Reserved				
000680 _H	CSER [R/W] 00000001	CHER [R/W] 11111111	Reserved	TCR [R/W] 0000**** *5	
000684 _H	RCRH [R/W] 00XXXXXX	RCRL [R/W] XXXX0XXX	Reserved		
000688 _H to 0007F8 _H	Reserved				
0007FC _H	Reserved	MODR [W] XXXXXXXX	Reserved		Mode Register

(Continued)

MB91460S Series

Address	Register				Block
	+ 0	+ 1	+ 2	+ 3	
000800 _H to 000CFC _H	Reserved				
000D00 _H	PDRD00 [R] XXXXXXXX	PDRD01 [R] XXXXXXXX	Reserved		R-bus Port Data Direct Read Register
000D04 _H	Reserved	PDRD05 [R] XXXXXXXX	PDRD06 [R] XXXXXXXX	PDRD07 [R] XXXXXXXX	
000D08 _H	PDRD08 [R] X - - X - - XX	PDRD09 [R] - - - - XXXX	PDRD10 [R] - - - - X - XX	Reserved	
000D0C _H	Reserved		PDRD14 [R] XXXXXXXX	PDRD15 [R] - - - - XXXX	
000D10 _H	PDRD16 [R] XXXXXXXX	PDRD17 [R] XXXXXXXX	PDRD18 [R] - XXX - XXX	PDRD19 [R] - XXX - XXX	
000D14 _H	PDRD20 [R] - XXX - XXX	Reserved	PDRD22 [R] XXXX - X - X	PDRD23 [R] -X - XXXXX	
000D18 _H	PDRD24 [R] XXXXXXXX	Reserved	Reserved		
000D1C _H	PDRD28 [R] XXXXXXXX	PDRD29 [R] XXXXXXXX	Reserved		
000D20 _H to 000D3C _H	Reserved				
000D40 _H	DDR00 [R/W] 00000000	DDR01 [R/W] 00000000	Reserved		R-bus Port Direction Register
000D44 _H	Reserved	DDR05 [R/W] 00000000	DDR06 [R/W] 00000000	DDR07 [R/W] 00000000	
000D48 _H	DDR08 [R/W] 0 - - 0 - - 00	DDR09 [R/W] - - - - 0000	DDR10 [R/W] - - - - 0 - 00	Reserved	
000D4C _H	Reserved	Reserved	DDR14 [R/W] 00000000	DDR15 [R/W] - - - - 0000	
000D50 _H	DDR16 [R/W] 00000000	DDR17 [R/W] 00000000	DDR18 [R/W] - 000 - 000	DDR19 [R/W] - 000 - 000	
000D54 _H	DDR20 [R/W] - 000 - 000	Reserved	DDR22 [R/W] 0000 - 0 - 0	DDR23 [R/W] - 0 - 00000	
000D58 _H	DDR24 [R/W] 00000000	Reserved	Reserved	Reserved	
000D5C _H	DDR28 [R/W] 00000000	DDR29 [R/W] 00000000	Reserved		
000D60 _H to 000D7C _H	Reserved				

(Continued)

MB91460S Series

Address	Register				Block
	+ 0	+ 1	+ 2	+ 3	
000D80 _H	PFR00 [R/W] 00000000	PFR01 [R/W] 00000000	Reserved		R-bus Port Function Register
000D84 _H	Reserved	PFR05 [R/W] 00000000	PFR06 [R/W] 00000000	PFR07 [R/W] 00000000	
000D88 _H	PFR08 [R/W] 0 - - 0 - - 00	PFR09 [R/W] - - - - 0000	PFR10 [R/W] - - - - 0 - 00	Reserved	
000D8C _H	Reserved		PFR14 [R/W] 00000000	PFR15 [R/W] - - - - 0000	
000D90 _H	PFR16 [R/W] 00000000	PFR17 [R/W] 00000000	PFR18 [R/W] - 000 - 000	PFR19 [R/W] - 000 - 000	
000D94 _H	PFR20 [R/W] - 000 - 000	Reserved	PFR22 [R/W] 0000 - 0 - 0	PFR23 [R/W] - 0 - 00000	
000D98 _H	PFR24 [R/W] 00000000	Reserved			
000D9C _H	PFR28 [R/W] 00000000	PFR29 [R/W] 00000000	Reserved		
000DA0 _H to 000DBC _H	Reserved				
000DC0 _H	EPFR00 [R/W] - - - - - - - -	EPFR01 [R/W] - - - - - - - -	Reserved		R-bus Extra Port Function Register
000DC4 _H	Reserved	EPFR05 [R/W] - - - - - - - -	EPFR06 [R/W] - - - - - - - -	EPFR07 [R/W] - - - - - - - -	
000DC8 _H	EPFR08 [R/W] - - - - - - - -	EPFR09 [R/W] - - - - - - - -	EPFR10 [R/W] - - - - - - 0	Reserved	
000DCC _H	Reserved		EPFR14 [R/W] 00000000	EPFR15 [R/W] - - - - 0000	
000DD0 _H	EPFR16 [R/W] 0000 - - - -	EPFR17 [R/W] - 000 - 000	EPFR18 [R/W] - 000 - 000	EPFR19 [R/W] - 0 - - - 0 - -	
000DD4 _H	EPFR20 [R/W] - 000 - 000	Reserved	EPFR22 [R/W] - - - - - - - -	EPFR23 [R/W] - - - - - - - -	
000DD8 _H	EPFR24 [R/W] - - - - - - - -	Reserved			
000DDC _H	EPFR28 [R/W] - 000 - 000	EPFR29 [R/W] - - - - - - - -	Reserved		
000DE0 _H to 000DFC _H	Reserved				

(Continued)

MB91460S Series

Address	Register				Block
	+ 0	+ 1	+ 2	+ 3	
000E00H	PODR00 [R/W] 00000000	PODR01 [R/W] 00000000	Reserved		R-bus Port Output Drive Select Register
000E04H	Reserved	PODR05 [R/W] 00000000	PODR06 [R/W] 00000000	PODR07 [R/W] 00000000	
000E08H	PODR08 [R/W] 0 - - 0 - - 00	PODR09 [R/W] - - - - 0000	PODR10 [R/W] - - - - 0 - 00	Reserved	
000E0CH	Reserved		PODR14 [R/W] 00000000	PODR15 [R/W] - - - - 0000	
000E10H	PODR16 [R/W] 00000000	PODR17 [R/W] 0000 - - - -	PODR18 [R/W] - 000 - 000	PODR19 [R/W] - 000 - 000	
000E14H	PODR20 [R/W] - 000 - 000	Reserved	PODR22 [R/W] 0000 - 0 - 0	PODR23 [R/W] - 0 - 00000	
000E18H	PODR24 [R/W] 00000000	Reserved			
000E1CH	PODR28 [R/W] 00000000	PODR29 [R/W] 00000000	Reserved		
000E20H to 000E3CH	Reserved				
000E40H	PILR00 [R/W] 00000000	PILR01 [R/W] 00000000	Reserved		R-bus Port Input Level Select Register
000E44H	Reserved	PILR05 [R/W] 00000000	PILR06 [R/W] 00000000	PILR07 [R/W] 00000000	
000E48H	PILR08 [R/W] 0 - - 0 - - 00	PILR09 [R/W] - - - - 0000	PILR10 [R/W] - - - - 0 - 00	Reserved	
000E4CH	Reserved		PILR14 [R/W] 00000000	PILR15 [R/W] - - - - 0000	
000E50H	PILR16 [R/W] 00000000	PILR17 [R/W] 0000 - - - -	PILR18 [R/W] - 000 - 000	PILR19 [R/W] - 000 - 000	
000E54H	PILR20 [R/W] - 000 - 000	Reserved	PILR22 [R/W] 0000 - 0 - 0	PILR23 [R/W] - 0 - 00000	
000E58H	PILR24 [R/W] 00000000	Reserved			
000E5CH	PILR28 [R/W] 00000000	PILR29 [R/W] 00000000	Reserved		
000E60H to 000E7CH	Reserved				

(Continued)

MB91460S Series

Address	Register				Block
	+ 0	+ 1	+ 2	+ 3	
000E80 _H	EPILR00 [R/W] 00000000	EPILR01 [R/W] 00000000	Reserved		R-bus Extra Port Input Level Select Register
000E84 _H	Reserved	EPILR05 [R/W] 00000000	EPILR06 [R/W] 00000000	EPILR07 [R/W] 00000000	
000E88 _H	EPILR08 [R/W] 0 - - 0 - - 00	EPILR09 [R/W] - - - - 0000	EPILR10 [R/W] - - - - 0 - 00	Reserved	
000E8C _H	Reserved		EPILR14 [R/W] 00000000	EPILR15 [R/W] - - - - 0000	
000E90 _H	EPILR16 [R/W] 00000000	EPILR17 [R/W] 0000 - - - -	EPILR18 [R/W] - 000 - 000	EPILR19 [R/W] - 000 - 000	
000E94 _H	EPILR20 [R/W] - 000 - 000	Reserved	EPILR22 [R/W] 0000 - 0 - 0	EPILR23 [R/W] - 0 - 00000	
000E98 _H	EPILR24 [R/W] 00000000	Reserved			
000E9C _H	EPILR28 [R/W] 00000000	EPILR29 [R/W] 00000000	Reserved		
000EA0 _H to 000EBC _H	Reserved				
000EC0 _H	PPER00 [R/W] 00000000	PPER01 [R/W] 00000000	Reserved		R-bus Port Pull-Up/Down Enable Register
000EC4 _H	Reserved	PPER05 [R/W] 00000000	PPER06 [R/W] 00000000	PPER07 [R/W] 00000000	
000EC8 _H	PPER08 [R/W] 0 - - 0 - - 00	PPER09 [R/W] - - - - 0000	PPER10 [R/W] - - - - 0 - 00	Reserved	
000ECC _H	Reserved		PPER14 [R/W] 00000000	PPER15 [R/W] - - - - 0000	
000ED0 _H	PPER16 [R/W] 00000000	PPER17 [R/W] 0000 - - - -	PPER18 [R/W] - 000 - 000	PPER19 [R/W] - 000 - 000	
000ED4 _H	PPER20 [R/W] - 000 - 000	Reserved	PPER22 [R/W] 0000 - 0 - 0	PPER23 [R/W] - 0 - 00000	
000ED8 _H	PPER24 [R/W] 00000000	Reserved			
000EDC _H	PPER28 [R/W] 00000000	PPER29 [R/W] 00000000	Reserved		
000EE0 _H to 000EFC _H	Reserved				

(Continued)

MB91460S Series

Address	Register				Block
	+ 0	+ 1	+ 2	+ 3	
000F00 _H	PPCR00 [R/W] 11111111	PPCR01 [R/W] 11111111	Reserved		R-bus Port Pull-Up/Down Control Register
000F04 _H	Reserved	PPCR05 [R/W] 11111111	PPCR06 [R/W] 11111111	PPCR07 [R/W] 11111111	
000F08 _H	PPCR08 [R/W] 1 - - 1 - - 11	PPCR09 [R/W] - - - - 1111	PPCR10 [R/W] - - - - 1 - 11	Reserved	
000F0C _H	Reserved		PPCR14 [R/W] 11111111	PPCR15 [R/W] - - - - 1111	
000F10 _H	PPCR16 [R/W] 11111111	PPCR17 [R/W] 11111111	PPCR18 [R/W] - 111 - 111	PPCR19 [R/W] - 111 - 111	
000F14 _H	PPCR20 [R/W] - 111 - 111	Reserved	PPCR22 [R/W] 1111 - 1 - 1	PPCR23 [R/W] - 1 - 11111	
000F18 _H	PPCR24 [R/W] 11111111	Reserved			
000F1C _H	PPCR28 [R/W] 11111111	PPCR29 [R/W] 11111111	Reserved		
000F20 _H to 000F3C _H	Reserved				
001000 _H	DMASA0 [R/W] XXXXXXXX XXXXXXXX XXXXXXXX XXXXXXXX				DMAC
001004 _H	DMADA0 [R/W] XXXXXXXX XXXXXXXX XXXXXXXX XXXXXXXX				
001008 _H	DMASA1 [R/W] XXXXXXXX XXXXXXXX XXXXXXXX XXXXXXXX				
00100C _H	DMADA1 [R/W] XXXXXXXX XXXXXXXX XXXXXXXX XXXXXXXX				
001010 _H	DMASA2 [R/W] XXXXXXXX XXXXXXXX XXXXXXXX XXXXXXXX				
001014 _H	DMADA2 [R/W] XXXXXXXX XXXXXXXX XXXXXXXX XXXXXXXX				
001018 _H	DMASA3 [R/W] XXXXXXXX XXXXXXXX XXXXXXXX XXXXXXXX				
00101C _H	DMADA3 [R/W] XXXXXXXX XXXXXXXX XXXXXXXX XXXXXXXX				
001020 _H	DMASA4 [R/W] XXXXXXXX XXXXXXXX XXXXXXXX XXXXXXXX				
001024 _H	DMADA4 [R/W] XXXXXXXX XXXXXXXX XXXXXXXX XXXXXXXX				

(Continued)

MB91460S Series

Address	Register				Block
	+ 0	+ 1	+ 2	+ 3	
001028 _H to 001FFC _H	Reserved				
002000 _H to 006FFC _H	MB91F467SA Flash-cache size is 8 Kbytes : 004000 _H to 005FFC _H				Flash-cache / I-RAM area
007000 _H	FMCS [R/W] 01101000	FMCR [R] --- 00000	FCHCR [R/W] ----- 00 10000011		Flash Memory/ Flash-cache/ I-RAM Control Register
007004 _H	FMWT [R/W] 11111111 11111111		FMWT2 [R] - 001 ----	FMPS [R/W] ----- 000	
007008 _H	FMAC [R] 00000000 00000000 00000000 00000000				
00700C _H	FCHA0 [R/W] ----- --- 00000 00000000 00000000				
007010 _H	FCHA1 [R/W] ----- --- 00000 00000000 00000000				Flash-cache Non- cacheable area setting Register
007014 _H to 0071FC _H	Reserved				
007200 _H	RHCTRL[R/W] 00 -- 0000 ----- 0000 - 000 -----				Automotive Remote Handler Control
007204 _H	Reserved				
007208 _H	CHCTRL0[R/W] ---- 0 --- 000 --- 00 00000000 -- 00 -- 000				APIX [®] Control/Status
00720C _H	CHSTAT0[R] 00000000 ----- 00000000 00000000				
007210 _H	CHWDG0[R/W] 00 -- 0000 00000000 xxxxxxxx xxxxxxxx				
007214 _H	CHCTRL1[R/W] ---- 0 --- 000 --- 00 00000000 -- 00 -- 000				
007218 _H	CHSTAT1[R] 00000000 ----- 00000000 00000000				
00721C _H	CHWDG1[R/W] 00 -- 0000 00000000 xxxxxxxx xxxxxxxx				

(Continued)

MB91460S Series

Address	Register				Block
	+ 0	+ 1	+ 2	+ 3	
007220 _H	TBCTRL00[R/W] --- 00000 0000 - 000		TBCTRL01[R/W] --- 00000 0000 - 000		Automotive Remote Handler Transaction Buffer Control
007224 _H	TBCTRL02[R/W] --- 00000 0000 - 000		TBCTRL03[R/W] --- 00000 0000 - 000		
007228 _H	TBCTRL04[R/W] --- 00000 0000 - 000		TBCTRL05[R/W] --- 00000 0000 - 000		
00722C _H	TBCTRL06[R/W] --- 00000 0000 - 000		TBCTRL07[R/W] --- 00000 0000 - 000		
007230 _H	TBCTRL08[R/W] --- 00000 0000 - 000		TBCTRL09[R/W] --- 00000 0000 - 000		
007234 _H	TBCTRL10[R/W] --- 00000 0000 - 000		TBCTRL11[R/W] --- 00000 0000 - 000		
007238 _H	TBCTRL12[R/W] --- 00000 0000 - 000		TBCTRL13[R/W] --- 00000 0000 - 000		
00723C _H	TBCTRL14[R/W] --- 00000 0000 - 000		TBCTRL15[R/W] --- 00000 0000 - 000		
007240 _H	TBIRQ[R] 00000000 00000000		Reserved		Automotive Remote Handler Interrupt
007244 _H to 00724C _H	Reserved				
007250 _H	TFCRTL00[R/W] 00 - 00000	TFIDX00[R/W] 00000000	TFCRTL01[R/W] 00 - 00000	TFIDX01[R/W] 00000000	Transaction Frame
007254 _H	TFCRTL02[R/W] 00 - 00000	TFIDX02[R/W] 00000000	TFCRTL03[R/W] 00 - 00000	TFIDX03[R/W] 00000000	
007258 _H	TFCRTL04[R/W] 00 - 00000	TFIDX04[R/W] 00000000	TFCRTL05[R/W] 00 - 00000	TFIDX05[R/W] 00000000	
00725C _H	TFCRTL06[R/W] 00 - 00000	TFIDX06[R/W] 00000000	TFCRTL07[R/W] 00 - 00000	TFIDX07[R/W] 00000000	
007260 _H	TFCRTL08[R/W] 00 - 00000	TFIDX08[R/W] 00000000	TFCRTL09[R/W] 00 - 00000	TFIDX09[R/W] 00000000	
007264 _H	TFCRTL10[R/W] 00 - 00000	TFIDX10[R/W] 00000000	TFCRTL11[R/W] 00 - 00000	TFIDX11[R/W] 00000000	
007268 _H	TFCRTL12[R/W] 00 - 00000	TFIDX12[R/W] 00000000	TFCRTL13[R/W] 00 - 00000	TFIDX13[R/W] 00000000	
00726C _H	TFCRTL14[R/W] 00 - 00000	TFIDX14[R/W] 00000000	TFCRTL15[R/W] 00 - 00000	TFIDX15[R/W] 00000000	
007270 _H	TFADDR00[R/W] ----- 0000 00000000 00000000				
007274 _H	TFADDR01[R/W] ----- 0000 00000000 00000000				

(Continued)

MB91460S Series

Address	Register				Block
	+ 0	+ 1	+ 2	+ 3	
007278 _H	TFADDR02[R/W] ----- 0000 00000000 00000000				
00727C _H	TFADDR03[R/W] ----- 0000 00000000 00000000				
007280 _H	TFADDR04[R/W] ----- 0000 00000000 00000000				
007284 _H	TFADDR05[R/W] ----- 0000 00000000 00000000				
007288 _H	TFADDR06[R/W] ----- 0000 00000000 00000000				
00728C _H	TFADDR07[R/W] ----- 0000 00000000 00000000				
007290 _H	TFADDR08[R/W] ----- 0000 00000000 00000000				
007294 _H	TFADDR09[R/W] ----- 0000 00000000 00000000				
007298 _H	TFADDR10[R/W] ----- 0000 00000000 00000000				
00729C _H	TFADDR11[R/W] ----- 0000 00000000 00000000				
0072A0 _H	TFADDR12[R/W] ----- 0000 00000000 00000000				
0072A4 _H	TFADDR13[R/W] ----- 0000 00000000 00000000				
0072A8 _H	TFADDR14[R/W] ----- 0000 00000000 00000000				
0072AC _H	TFADDR15[R/W] ----- 0000 00000000 00000000				
0072B0 _H	TFDATA00[R/W] 00000000 00000000 00000000 00000000				
0072B4 _H	TFDATA01[R/W] 00000000 00000000 00000000 00000000				
0072B8 _H	TFDATA02[R/W] 00000000 00000000 00000000 00000000				
0072BC _H	TFDATA03[R/W] 00000000 00000000 00000000 00000000				
0072C0 _H	TFDATA04[R/W] 00000000 00000000 00000000 00000000				
0072C4 _H	TFDATA05[R/W] 00000000 00000000 00000000 00000000				
0072C8 _H	TFDATA06[R/W] 00000000 00000000 00000000 00000000				

(Continued)

MB91460S Series

Address	Register				Block	
	+ 0	+ 1	+ 2	+ 3		
0072CC _H	TFDATA07[R/W] 00000000 00000000 00000000 00000000					
0072D0 _H	TFDATA08[R/W] 00000000 00000000 00000000 00000000					
0072D4 _H	TFDATA09[R/W] 00000000 00000000 00000000 00000000					
0072D8 _H	TFDATA10[R/W] 00000000 00000000 00000000 00000000					
0072DC _H	TFDATA11[R/W] 00000000 00000000 00000000 00000000					
0072E0 _H	TFDATA12[R/W] 00000000 00000000 00000000 00000000					
0072E4 _H	TFDATA13[R/W] 00000000 00000000 00000000 00000000					
0072E8 _H	TFDATA14[R/W] 00000000 00000000 00000000 00000000					
0072EC _H	TFDATA15[R/W] 00000000 00000000 00000000 00000000					
0072F0 _H	EVCTRL[R/W] ----- 0 0 - 000000 00000000 00000000					Automotive Remote Handler Eventcontrol
0072F4 _H	Reserved					
0072F8 _H	EVBUF0[R/W] ----- 0 00000000 -----					Automotive Remote Handler Eventqueue
0072FC _H	EVBUF1[R/W] 00000000 00000000 00000000 00000000					
007300 _H	APCFG00[R/W] 00000000 00110000 00000000 10010000					APIX® Configuration
007304 _H	APCFG01[R/W] 11110000 10000000 00000000 01001000					
007308 _H	APCFG02[R/W] 00000010 00000010 01000000 -----					
00730C _H	APCFG03[R/W] 00100110 10100000 10011010 00 --- 000					
007310 _H	APCFG10[R/W] 00000000 00110000 00000000 10010000					
007314 _H	APCFG11[R/W] 11110000 00000000 00000000 01001000					
007318 _H	APCFG12[R/W] 00000010 00000010 01000000 -----					
00731C _H	APCFG13[R/W] 00100110 10100100 10011010 00 --- 000					

(Continued)

MB91460S Series

Address	Register				Block
	+ 0	+ 1	+ 2	+ 3	
00C040 _H	IF2CREQ0 [R/W] 00000000 00000001		IF2CMSK0 [R/W] 00000000 00000000		CAN 0 IF 2 Register
00C044 _H	IF2MSK20 [R/W] 11111111 11111111		IF2MSK10 [R/W] 11111111 11111111		
00C048 _H	IF2ARB20 [R/W] 00000000 00000000		IF2ARB10 [R/W] 00000000 00000000		
00C04C _H	IF2MCTR0 [R/W] 00000000 00000000		Reserved		
00C050 _H	IF2DTA10 [R/W] 00000000 00000000		IF2DTA20 [R/W] 00000000 00000000		
00C054 _H	IF2DTB10 [R/W] 00000000 00000000		IF2DTB20 [R/W] 00000000 00000000		
00C058 _H , 00C05C _H	Reserved				
00C060 _H	IF2DTA20 [R/W] 00000000 00000000		IF2DTA10 [R/W] 00000000 00000000		
00C064 _H	IF2DTB20 [R/W] 00000000 00000000		IF2DTB10 [R/W] 00000000 00000000		
00C068 _H to 00C07C _H	Reserved				
00C080 _H	TREQR20 [R] 00000000 00000000		TREQR10 [R] 00000000 00000000		CAN 0 Status Flags
00C084 _H to 00C08C _H	Reserved				
00C090 _H	NEWDT20 [R] 00000000 00000000		NEWDT10 [R] 00000000 00000000		
00C094 _H to 00C09C _H	Reserved				
00C0A0 _H	INTPND20 [R] 00000000 00000000		INTPND10 [R] 00000000 00000000		
00C0A4 _H to 00C0AC _H	Reserved				
00C0B0 _H	MSGVAL20 [R] 00000000 00000000		MSGVAL10 [R] 00000000 00000000		
00C0B4 _H to 00C0FC _H	Reserved				

(Continued)

MB91460S Series

Address	Register				Block
	+ 0	+ 1	+ 2	+ 3	
00C100H	CTRLR1 [R/W] 00000000 00000001		STATR1 [R/W] 00000000 00000000		CAN 1 Control Register
00C104H	ERRCNT1 [R] 00000000 00000000		BTR1 [R/W] 00100011 00000001		
00C108H	INTR1 [R] 00000000 00000000		TESTR1 [R/W] 00000000 X0000000		
00C10CH	BRPE1 [R/W] 00000000 00000000		Reserved		
00C110H	IF1CREQ1 [R/W] 00000000 00000001		IF1CMSK1 [R/W] 00000000 00000000		CAN 1 IF 1 Register
00C114H	IF1MSK21 [R/W] 11111111 11111111		IF1MSK11 [R/W] 11111111 11111111		
00C118H	IF1ARB21 [R/W] 00000000 00000000		IF1ARB11 [R/W] 00000000 00000000		
00C11CH	IF1MCTR1 [R/W] 00000000 00000000		Reserved		
00C120H	IF1DTA11 [R/W] 00000000 00000000		IF1DTA21 [R/W] 00000000 00000000		
00C124H	IF1DTB11 [R/W] 00000000 00000000		IF1DTB21 [R/W] 00000000 00000000		
00C128H, 00C12CH	Reserved				CAN 1 IF 1 Register
00C130H	IF1DTA21 [R/W] 00000000 00000000		IF1DTA11 [R/W] 00000000 00000000		
00C134H	IF1DTB21 [R/W] 00000000 00000000		IF1DTB11 [R/W] 00000000 00000000		
00C138H, 00C13CH	Reserved				

(Continued)

MB91460S Series

Address	Register				Block
	+ 0	+ 1	+ 2	+ 3	
00C140 _H	IF2CREQ1 [R/W] 00000000 00000001		IF2CMSK1 [R/W] 00000000 00000000		CAN 1 IF 2 Register
00C144 _H	IF2MSK21 [R/W] 11111111 11111111		IF2MSK11 [R/W] 11111111 11111111		
00C148 _H	IF2ARB21 [R/W] 00000000 00000000		IF2ARB11 [R/W] 00000000 00000000		
00C14C _H	IF2MCTR1 [R/W] 00000000 00000000		Reserved		
00C150 _H	IF2DTA11 [R/W] 00000000 00000000		IF2DTA21 [R/W] 00000000 00000000		
00C154 _H	IF2DTB11 [R/W] 00000000 00000000		IF2DTB21 [R/W] 00000000 00000000		
00C158 _H , 00C15C _H	Reserved				
00C160 _H	IF2DTA21 [R/W] 00000000 00000000		IF2DTA11 [R/W] 00000000 00000000		
00C164 _H	IF2DTB21 [R/W] 00000000 00000000		IF2DTB11 [R/W] 00000000 00000000		
00C168 _H to 00C17C _H	Reserved				
00C180 _H	TREQR21 [R] 00000000 00000000		TREQR11 [R] 00000000 00000000		CAN 1 Status Flags
00C184 _H to 00C18C _H	Reserved				
00C190 _H	NEWDT21 [R] 00000000 00000000		NEWDT11 [R] 00000000 00000000		
00C194 _H to 00C19C _H	Reserved				
00C1A0 _H	INTPND21 [R] 00000000 00000000		INTPND11 [R] 00000000 00000000		CAN 1 Status Flags
00C1A4 _H to 00C1AC _H	Reserved				
00C1B0 _H	MSGVAL21 [R] 00000000 00000000		MSGVAL11 [R] 00000000 00000000		
00C1B4 _H to 00C1FC _H	Reserved				

(Continued)

MB91460S Series

Address	Register				Block
	+ 0	+ 1	+ 2	+ 3	
00C200H to 00EFFCH	Reserved				
00F00H	BCTRL [R/W] ----- 11111100 00000000				EDSU / MPU
00F04H	BSTAT [R/W] ----- 000 00000000 10 -- 0000				
00F08H	BIAC [R] ----- 00000000 00000000				
00F0CH	BOAC [R] ----- 00000000 00000000				
00F10H	BIRQ [R/W] ----- 00000000 00000000				
00F14H to 00F1CH	Reserved				
00F20H	BCR0 [R/W] ----- 00000000 00000000 00000000				
00F24H	BCR1 [R/W] ----- 00000000 00000000 00000000				
00F28H	BCR2 [R/W] ----- 00000000 00000000 00000000				
00F2CH	BCR3 [R/W] ----- 00000000 00000000 00000000				
00F30H to 00F7CH	Reserved				
00F80H	BAD0 [R/W] XXXXXXXX XXXXXXXX XXXXXXXX XXXXXXXX				EDSU / MPU
00F84H	BAD1 [R/W] XXXXXXXX XXXXXXXX XXXXXXXX XXXXXXXX				
00F88H	BAD2 [R/W] XXXXXXXX XXXXXXXX XXXXXXXX XXXXXXXX				
00F8CH	BAD3 [R/W] XXXXXXXX XXXXXXXX XXXXXXXX XXXXXXXX				
00F90H	BAD4 [R/W] XXXXXXXX XXXXXXXX XXXXXXXX XXXXXXXX				
00F94H	BAD5 [R/W] XXXXXXXX XXXXXXXX XXXXXXXX XXXXXXXX				
00F98H	BAD6 [R/W] XXXXXXXX XXXXXXXX XXXXXXXX XXXXXXXX				

(Continued)

MB91460S Series

(Continued)

Address	Register				Block
	+ 0	+ 1	+ 2	+ 3	
00F09C _H	BAD7 [R/W] XXXXXXXX XXXXXXXX XXXXXXXX XXXXXXXX				EDSU / MPU
00F0A0 _H	BAD8 [R/W] XXXXXXXX XXXXXXXX XXXXXXXX XXXXXXXX				
00F0A4 _H	BAD9 [R/W] XXXXXXXX XXXXXXXX XXXXXXXX XXXXXXXX				
00F0A8 _H	BAD10 [R/W] XXXXXXXX XXXXXXXX XXXXXXXX XXXXXXXX				
00F0AC _H	BAD11 [R/W] XXXXXXXX XXXXXXXX XXXXXXXX XXXXXXXX				
00F0B0 _H	BAD12 [R/W] XXXXXXXX XXXXXXXX XXXXXXXX XXXXXXXX				
00F0B4 _H	BAD13 [R/W] XXXXXXXX XXXXXXXX XXXXXXXX XXXXXXXX				
00F0B8 _H	BAD14 [R/W] XXXXXXXX XXXXXXXX XXXXXXXX XXXXXXXX				
00F0BC _H	BAD15 [R/W] XXXXXXXX XXXXXXXX XXXXXXXX XXXXXXXX				
00F0C0 _H to 01FFFC _H	Reserved				
020000 _H to 02FFFC _H	MB91F467SA D-RAM size is 32 Kbytes : 028000 _H to 02FFFC _H (data access is 0 wait cycles)				D-RAM area
030000 _H to 037FFC _H	MB91F467SA ID-RAM size is 32 Kbytes : 030000 _H to 037FFC _H (instruction access is 0 wait cycles, data access is 1 wait cycle)				ID-RAM area
038000 _H to 03FFFC _H	Reserved				

*1 : Use a read access (byte or halfword) to this address to synchronize the CPU operation (e.g. the interrupt acceptance of the CPU) to a preceding write access to the resources on R-bus (e.g. to an interrupt flag) on following address (0x0000-0x01FF, 0x0280-0x037F, 0x0400-0x063F and 0x0C00-0x0FFF).

*2 : Use a read access (byte or halfword) to this address to synchronize the CPU operation (e.g. the interrupt acceptance of the CPU) to a preceding write access to the CANS on D-bus (e.g. to an interrupt flag) on following address (0x0000-0xFFFF).

*3 : depends on the number of available CAN channels

*4 : ACR0 [11 : 10] depends on Mode vector fetch information on bus width

*5 : TCR [3 : 0] INIT value = 0000, keeps value after RST

*6 : Datecode of APIX[®] controller version

2. Flash memory and external bus area

32bit write mode	dat[31:0]				dat[31:0]				Block
16bit write mode	dat[31:16]		dat[15:0]		dat[31:16]		dat[15:0]		
Address	Register								
	+ 0	+ 1	+ 2	+ 3	+ 4	+ 5	+ 6	+ 7	
040000H to 05FFF8H	SA8 (64kB)				SA9 (64kB)				ROMS0
060000H to 07FFF8H	SA10 (64kB)				SA11 (64kB)				ROMS1
080000H to 09FFF8H	SA12 (64kB)				SA13 (64kB)				ROMS2
0A0000H to 0BFFF8H	SA14 (64kB)				SA15 (64kB)				ROMS3
0C0000H to 0DFFF8H	SA16 (64kB)				SA17 (64kB)				ROMS4
0E0000H to 0FFFF0H	SA18 (64kB)				SA19 (64kB)				ROMS5
0FFFF8H	FMV [R] 06 00 00 00H				FRV [R] 00 00 BF F8H				
100000H to 11FFF8H	SA20 (64kB)				SA21 (64kB)				ROMS6
120000H to 13FFF8H	SA22 (64kB)				SA23 (64kB)				
140000H to 143FF8H	SA0 (8kB)				SA1 (8kB)				ROMS7
144000H to 17FF8H	SA2 (8kB)				SA3 (8kB)				
148000H to 14BFF8H	SA4 (8kB)				SA5 (8kB)				
14C000H to 14FFF8H	SA6 (8kB)				SA7 (8kB)				
150000H to 17FFF8H	Reserved								

(Continued)

MB91460S Series

(Continued)

32bit write mode	dat[31:0]				dat[31:0]				Block
	16bit write mode		dat[15:0]		dat[31:16]		dat[15:0]		
Address	Register								Block
	+ 0	+ 1	+ 2	+ 3	+ 4	+ 5	+ 6	+ 7	
180000H to 1BFFF8H	External Bus Area								ROMS8
1C0000H to 1FFFF8H									ROMS9
200000H to 27FFF8H									ROMS10
280000H to 2FFFF8H									ROMS11
300000H to 37FFF8H									ROMS12
380000H to 3FFFF8H									ROMS13
400000H to 47FFF8H									ROMS14
480000H to 4FFFF8H									ROMS15

Note: Write operations to address 0FFFF8H and 0FFFFCH are not possible. When reading these addresses, the values shown above will be read.

■ INTERRUPT VECTOR TABLE

Interrupt	Interrupt number		Interrupt level ¹		Interrupt vector ²		DMA	
	Decimal	Hexadecimal	Setting Register	Register address	Offset	Default Vector address	RN ⁵	Stop ⁶
Reset	0	00	—	—	3FC _H	000FFFFC _H	—	—
Mode vector	1	01	—	—	3F8 _H	000FFFF8 _H	—	—
System reserved	2	02	—	—	3F4 _H	000FFFF4 _H	—	—
System reserved	3	03	—	—	3F0 _H	000FFFF0 _H	—	—
System reserved	4	04	—	—	3EC _H	000FFFE _C	—	—
CPU supervisor mode (INT #5 instruction) ^{*7}	5	05	—	—	3E8 _H	000FFFE8 _H	—	—
Memory Protection exception ^{*7}	6	06	—	—	3E4 _H	000FFFE4 _H	—	—
System reserved	7	07	—	—	3E0 _H	000FFFE0 _H	—	—
System reserved	8	08	—	—	3DC _H	000FFFD _C	—	—
System reserved	9	09	—	—	3D8 _H	000FFFD8 _H	—	—
System reserved	10	0A	—	—	3D4 _H	000FFFD4 _H	—	—
System reserved	11	0B	—	—	3D0 _H	000FFFD0 _H	—	—
System reserved	12	0C	—	—	3CC _H	000FFFC _C	—	—
System reserved	13	0D	—	—	3C8 _H	000FFFC8 _H	—	—
Undefined instruction exception	14	0E	—	—	3C4 _H	000FFFC4 _H	—	—
NMI request	15	0F	F _H fixed		3C0 _H	000FFFC0 _H	—	—
External Interrupt 0	16	10	ICR00	440 _H	3BC _H	000FFFB _C	0, 16	—
External Interrupt 1	17	11			3B8 _H	000FFFB8 _H	1, 17	—
External Interrupt 2	18	12	ICR01	441 _H	3B4 _H	000FFFB4 _H	2, 18	—
External Interrupt 3	19	13			3B0 _H	000FFFB0 _H	3, 19	—
External Interrupt 4	20	14	ICR02	442 _H	3AC _H	000FFFA _C	20	—
External Interrupt 5	21	15			3A8 _H	000FFFA8 _H	21	—
External Interrupt 6	22	16	ICR03	443 _H	3A4 _H	000FFFA4 _H	22	—
External Interrupt 7	23	17			3A0 _H	000FFFA0 _H	23	—
External Interrupt 8	24	18	ICR04	444 _H	39C _H	000FFF9 _C	—	—
External Interrupt 9	25	19			398 _H	000FFF98 _H	—	—
External Interrupt 10	26	1A	ICR05	445 _H	394 _H	000FFF94 _H	—	—
External Interrupt 11	27	1B			390 _H	000FFF90 _H	—	—
External Interrupt 12	28	1C	ICR06	446 _H	38C _H	000FFF8 _C	—	—
External Interrupt 13	29	1D			388 _H	000FFF88 _H	—	—

(Continued)

MB91460S Series

Interrupt	Interrupt number		Interrupt level ¹		Interrupt vector ²		DMA	
	Decimal	Hexadecimal	Setting Register	Register address	Offset	Default Vector address	RN ⁵	Stop ⁶
External Interrupt 14	30	1E	ICR07	447 _H	384 _H	000FFF84 _H	—	—
External Interrupt 15	31	1F			380 _H	000FFF80 _H	—	—
Reload Timer 0	32	20	ICR08	448 _H	37C _H	000FFF7C _H	4, 32	—
Reload Timer 1	33	21			378 _H	000FFF78 _H	5, 33	—
Reload Timer 2	34	22	ICR09	449 _H	374 _H	000FFF74 _H	34	—
Reload Timer 3	35	23			370 _H	000FFF70 _H	35	—
Reload Timer 4	36	24	ICR10	44A _H	36C _H	000FFF6C _H	36	—
Reload Timer 5	37	25			368 _H	000FFF68 _H	37	—
Reload Timer 6	38	26	ICR11	44B _H	364 _H	000FFF64 _H	38	—
Reload Timer 7	39	27			360 _H	000FFF60 _H	39	—
Free Run Timer 0	40	28	ICR12	44C _H	35C _H	000FFF5C _H	40	—
Free Run Timer 1	41	29			358 _H	000FFF58 _H	41	—
Free Run Timer 2	42	2A	ICR13	44D _H	354 _H	000FFF54 _H	42	—
Free Run Timer 3	43	2B			350 _H	000FFF50 _H	43	—
Free Run Timer 4	44	2C	ICR14	44E _H	34C _H	000FFF4C _H	44	—
Free Run Timer 5	45	2D			348 _H	000FFF48 _H	45	—
Free Run Timer 6	46	2E	ICR15	44F _H	344 _H	000FFF44 _H	46	—
Free Run Timer 7	47	2F			340 _H	000FFF40 _H	47	—
CAN 0	48	30	ICR16	450 _H	33C _H	000FFF3C _H	—	—
CAN 1	49	31			338 _H	000FFF38 _H	—	—
System reserved	50	32	ICR17	451 _H	334 _H	000FFF34 _H	—	—
System reserved	51	33			330 _H	000FFF30 _H	—	—
System reserved	52	34	ICR18	452 _H	32C _H	000FFF2C _H	—	—
System reserved	53	35			328 _H	000FFF28 _H	—	—
System reserved	54	36	ICR19	453 _H	324 _H	000FFF24 _H	6, 48	—
System reserved	55	37			320 _H	000FFF20 _H	7, 49	—
System reserved	56	38	ICR20	454 _H	31C _H	000FFF1C _H	8, 50	—
System reserved	57	39			318 _H	000FFF18 _H	9, 51	—
LIN-USART 2 RX	58	3A	ICR21	455 _H	314 _H	000FFF14 _H	52	—
LIN-USART 2 TX	59	3B			310 _H	000FFF10 _H	53	—
LIN-USART 3 RX	60	3C	ICR22	456 _H	30C _H	000FFF0C _H	54	—
LIN-USART 3 TX	61	3D			308 _H	000FFF08 _H	55	—

(Continued)

MB91460S Series

Interrupt	Interrupt number		Interrupt level ¹		Interrupt vector ²		DMA	
	Decimal	Hexadecimal	Setting Register	Register address	Offset	Default Vector address	RN ⁵	Stop ⁶
System reserved	62	3E	ICR23 ^{*3}	457 _H	304 _H	000FFF04 _H	—	—
Delayed Interrupt	63	3F			300 _H	000FFF00 _H	—	—
System reserved ^{*4}	64	40	(ICR24)	(458 _H)	2FC _H	000FFEFC _H	—	—
System reserved ^{*4}	65	41			2F8 _H	000FFEFC _H	—	—
LIN-USART (FIFO) 4 RX	66	42	ICR25	459 _H	2F4 _H	000FFEFC _H	10, 56	10, 56
LIN-USART (FIFO) 4 TX	67	43			2F0 _H	000FFEFC _H	11, 57	—
LIN-USART (FIFO) 5 RX	68	44	ICR26	45A _H	2EC _H	000FFEEC _H	12, 58	12, 58
LIN-USART (FIFO) 5 TX	69	45			2E8 _H	000FFEE8 _H	13, 59	—
LIN-USART (FIFO) 6 RX	70	46	ICR27	45B _H	2E4 _H	000FFEE4 _H	60	60
LIN-USART (FIFO) 6 TX	71	47			2E0 _H	000FFEE0 _H	61	—
LIN-USART (FIFO) 7 RX	72	48	ICR28	45C _H	2DC _H	000FFEDC _H	62	62
LIN-USART (FIFO) 7 TX	73	49			2D8 _H	000FFED8 _H	63	—
I ² C 0 / I ² C 2	74	4A	ICR29	45D _H	2D4 _H	000FFED4 _H	28, 30	28, 30
I ² C 1	75	4B			2D0 _H	000FFED0 _H	29	29
APIX [®] Event/ Eventlevel/ Eventbufferoverflow/ Fatal Error/ Watchdog	76	4C	ICR30	45E _H	2CC _H	000FFEC _H	—	—
System reserved	77	4D			2C8 _H	000FFEC8 _H	65	—
System reserved	78	4E	ICR31	45F _H	2C4 _H	000FFEC4 _H	66	—
System reserved	79	4F			2C0 _H	000FFEC0 _H	67	—
APIX [®] Transaction Buffer	80	50	ICR32	460 _H	2BC _H	000FFEB _H	160-175	160-175
System reserved	81	51			2B8 _H	000FFEB8 _H	69	—
System reserved	82	52	ICR33	461 _H	2B4 _H	000FFEB4 _H	70	—
System reserved	83	53			2B0 _H	000FFEB0 _H	71	—
System reserved	84	54	ICR34	462 _H	2AC _H	000FFEA _H	72	—
System reserved	85	55			2A8 _H	000FFEA8 _H	73	—
System reserved	86	56	ICR35	463 _H	2A4 _H	000FFEA4 _H	74	—
System reserved	87	57			2A0 _H	000FFEA0 _H	75	—
System reserved	88	58	ICR36	464 _H	29C _H	000FFE9 _H	76	—
System reserved	89	59			298 _H	000FFE98 _H	77	—
System reserved	90	5A	ICR37	465 _H	294 _H	000FFE94 _H	78	—
System reserved	91	5B			290 _H	000FFE90 _H	79	—

(Continued)

MB91460S Series

Interrupt	Interrupt number		Interrupt level ¹		Interrupt vector ²		DMA	
	Decimal	Hexadecimal	Setting Register	Register address	Offset	Default Vector address	RN ⁵	Stop ⁶
Input Capture 0	92	5C	ICR38	466 _H	28 _{C_H}	000FFE8 _{C_H}	80	—
Input Capture 1	93	5D			288 _H	000FFE88 _H	81	—
Input Capture 2	94	5E	ICR39	467 _H	284 _H	000FFE84 _H	82	—
Input Capture 3	95	5F			280 _H	000FFE80 _H	83	—
Input Capture 4	96	60	ICR40	468 _H	27 _{C_H}	000FFE7 _{C_H}	84	—
Input Capture 5	97	61			278 _H	000FFE78 _H	85	—
Input Capture 6	98	62	ICR41	469 _H	274 _H	000FFE74 _H	86	—
Input Capture 7	99	63			270 _H	000FFE70 _H	87	—
Output Compare 0	100	64	ICR42	46A _H	26 _{C_H}	000FFE6 _{C_H}	88	—
Output Compare 1	101	65			268 _H	000FFE68 _H	89	—
Output Compare 2	102	66	ICR43	46B _H	264 _H	000FFE64 _H	90	—
Output Compare 3	103	67			260 _H	000FFE60 _H	91	—
System reserved	104	68	ICR44	46C _H	25 _{C_H}	000FFE5 _{C_H}	92	—
System reserved	105	69			258 _H	000FFE58 _H	93	—
System reserved	106	6A	ICR45	46D _H	254 _H	000FFE54 _H	94	—
System reserved	107	6B			250 _H	000FFE50 _H	95	—
Sound Generator	108	6C	ICR46	46E _H	24 _{C_H}	000FFE4 _{C_H}	—	—
Phase Frequency Modulator	109	6D			248 _H	000FFE48 _H	—	—
System reserved	110	6E	ICR47 ^{*3}	46F _H	244 _H	000FFE44 _H	—	—
System reserved	111	6F			240 _H	000FFE40 _H	—	—
PPG0	112	70	ICR48	470 _H	23 _{C_H}	000FFE3 _{C_H}	15, 96	—
PPG1	113	71			238 _H	000FFE38 _H	97	—
PPG2	114	72	ICR49	471 _H	234 _H	000FFE34 _H	98	—
PPG3	115	73			230 _H	000FFE30 _H	99	—
PPG4	116	74	ICR50	472 _H	22 _{C_H}	000FFE2 _{C_H}	100	—
PPG5	117	75			228 _H	000FFE28 _H	101	—
PPG6	118	76	ICR51	473 _H	224 _H	000FFE24 _H	102	—
PPG7	119	77			220 _H	000FFE20 _H	103	—
PPG8	120	78	ICR52	474 _H	21 _{C_H}	000FFE1 _{C_H}	104	—
PPG9	121	79			218 _H	000FFE18 _H	105	—
PPG10	122	7A	ICR53	475 _H	214 _H	000FFE14 _H	106	—
PPG11	123	7B			210 _H	000FFE10 _H	107	—

(Continued)

(Continued)

Interrupt	Interrupt number		Interrupt level ^{*1}		Interrupt vector ^{*2}		DMA	
	Decimal	Hexadecimal	Setting Register	Register address	Offset	Default Vector address	RN ^{*5}	Stop ^{*6}
PPG12	124	7C	ICR54	476 _H	20C _H	000FFE0C _H	108	—
PPG13	125	7D			208 _H	000FFE08 _H	109	—
PPG14	126	7E	ICR55	477 _H	204 _H	000FFE04 _H	110	—
PPG15	127	7F			200 _H	000FFE00 _H	111	—
Up/Down Counter 0	128	80	ICR56	478 _H	1FC _H	000FFDFC _H	—	—
Up/Down Counter 1	129	81			1F8 _H	000FFDF8 _H	—	—
Up/Down Counter 2	130	82	ICR57	479 _H	1F4 _H	000FFDF4 _H	—	—
Up/Down Counter 3	131	83			1F0 _H	000FFDF0 _H	—	—
Real Time Clock	132	84	ICR58	47A _H	1EC _H	000FFDEC _H	—	—
Calibration Unit	133	85			1E8 _H	000FFDE8 _H	—	—
A/D Converter 0	134	86	ICR59	47B _H	1E4 _H	000FFDE4 _H	14, 112	—
System reserved	135	87			1E0 _H	000FFDE0 _H	—	—
Alarm Comparator 0	136	88	ICR60	47C _H	1DC _H	000FFDDC _H	—	—
System reserved	137	89			1D8 _H	000FFDD8 _H	—	—
Low Voltage Detection	138	8A	ICR61	47D _H	1D4 _H	000FFDD4 _H	—	—
SMC Comparator 0 to 5	139	8B			1D0 _H	000FFDD0 _H	—	—
Timebase Overflow	140	8C	ICR62	47E _H	1CC _H	000FFDCC _H	—	—
PLL Clock Gear	141	8D			1C8 _H	000FFDC8 _H	—	—
DMA Controller	142	8E	ICR63	47F _H	1C4 _H	000FFDC4 _H	—	—
Main/Sub OSC stability wait	143	8F			1C0 _H	000FFDC0 _H	—	—
Security vector	144	90	—	—	1BC _H	000FFDBC _H	—	—
Used by the INT instruction.	145 to 255	91 to FF	—	—	1B8 _H to 000 _H	000FFDB8 _H to 000FFC00 _H	—	—

*1 : The ICRs are located in the interrupt controller and set the interrupt level for each interrupt request. An ICR is provided for each interrupt request.

*2 : The vector address for each EIT (exception, interrupt or trap) is calculated by adding the listed offset to the table base register value (TBR) . The TBR specifies the top of the EIT vector table. The addresses listed in the table are for the default TBR value (000FFC00_H) . The TBR is initialized to this value by a reset. The TBR is set to 000FFC00_H after the internal boot ROM is executed.

*3 : ICR23 and ICR47 can be exchanged by setting the REALOS compatibility bit (addr 0C03_H : IOS[0])

*4 : Used by REALOS

*5 :DMA RN is the resource number used for DMA operation. No number means that this resource interrupt cannot be used to trigger a DMA transfer.

*6 :DMA Stop shows the DMA Transfer Stop Request feature.

*7 :Memory Protection Unit (MPU) support

MB91460S Series

■ RECOMMENDED SETTINGS

1. PLL and Clockgear settings

Please note that for MB91F467SA the core base clock frequencies are valid in the 1.8V operation mode of the Main regulator and Flash.

Recommended PLL divider and clockgear settings

PLL Input (CLK) [MHz]	Frequency Parameter		Clockgear Parameter		PLL Output (X) [MHz]	Core Base Clock [MHz]	Remarks
	DIVM	DIVN	DIVG	MULG			
4	2	25	16	24	200	100	
4	2	24	16	24	192	96	
4	2	23	16	24	184	92	
4	2	22	16	24	176	88	
4	2	21	16	20	168	84	
4	2	20	16	20	160	80	
4	2	19	16	20	152	76	
4	2	18	16	20	144	72	
4	2	17	16	16	136	68	
4	2	16	16	16	128	64	
4	2	15	16	16	120	60	
4	2	14	16	16	112	56	
4	2	13	16	12	104	52	
4	2	12	16	12	96	48	
4	2	11	16	12	88	44	
4	4	10	16	24	160	40	
4	4	9	16	24	144	36	
4	4	8	16	24	128	32	
4	4	7	16	24	112	28	
4	6	6	16	24	144	24	
4	8	5	16	28	160	20	
4	10	4	16	32	160	16	
4	12	3	16	32	144	12	

2. Clock Modulator settings

The clock modulator is currently being evaluated and should not be used for other purpose than testing.

The following table shows all possible settings for the Clock Modulator in a base clock frequency range from 32MHz up to 88MHz.

The Flash access time settings need to be adjusted according to Fmax while the PLL and clockgear settings should be set according to base clock frequency.

Clock Modulator settings, frequency range and supported supply voltage

Modulation Degree (k)	Random No (N)	CMPR [hex]	Baseclk [MHz]	Fmin [MHz]	Fmax [MHz]	Remarks
1	3	026F	88	79.5	98.5	
1	3	026F	84	76.1	93.8	
1	3	026F	80	72.6	89.1	
1	5	02AE	80	68.7	95.8	
2	3	046E	80	68.7	95.8	
1	3	026F	76	69.1	84.5	
1	5	02AE	76	65.3	90.8	
1	7	02ED	76	62	98.1	
2	3	046E	76	65.3	90.8	
3	3	066D	76	62	98.1	
1	3	026F	72	65.5	79.9	
1	5	02AE	72	62	85.8	
1	7	02ED	72	58.8	92.7	
2	3	046E	72	62	85.8	
3	3	066D	72	58.8	92.7	
1	3	026F	68	62	75.3	
1	5	02AE	68	58.7	80.9	
1	7	02ED	68	55.7	87.3	
1	9	032C	68	53	95	
2	3	046E	68	58.7	80.9	
2	5	04AC	68	53	95	
3	3	066D	68	55.7	87.3	
4	3	086C	68	53	95	
1	3	026F	64	58.5	70.7	
1	5	02AE	64	55.3	75.9	
1	7	02ED	64	52.5	82	
1	9	032C	64	49.9	89.1	
1	11	036B	64	47.6	97.6	
2	3	046E	64	55.3	75.9	

(Continued)

MB91460S Series

Modulation Degree (k)	Random No (N)	CMPR [hex]	Baseclk [MHz]	Fmin [MHz]	Fmax [MHz]	Remarks
2	5	04AC	64	49.9	89.1	
3	3	066D	64	52.5	82	
4	3	086C	64	49.9	89.1	
5	3	0A6B	64	47.6	97.6	
1	3	026F	60	54.9	66.1	
1	5	02AE	60	51.9	71	
1	7	02ED	60	49.3	76.7	
1	9	032C	60	46.9	83.3	
1	11	036B	60	44.7	91.3	
2	3	046E	60	51.9	71	
2	5	04AC	60	46.9	83.3	
3	3	066D	60	49.3	76.7	
4	3	086C	60	46.9	83.3	
5	3	0A6B	60	44.7	91.3	
1	3	026F	56	51.4	61.6	
1	5	02AE	56	48.6	66.1	
1	7	02ED	56	46.1	71.4	
1	9	032C	56	43.8	77.6	
1	11	036B	56	41.8	84.9	
1	13	03AA	56	39.9	93.8	
2	3	046E	56	48.6	66.1	
2	5	04AC	56	43.8	77.6	
2	7	04EA	56	39.9	93.8	
3	3	066D	56	46.1	71.4	
3	5	06AA	56	39.9	93.8	
4	3	086C	56	43.8	77.6	
5	3	0A6B	56	41.8	84.9	
6	3	0C6A	56	39.9	93.8	
1	3	026F	52	47.8	57	
1	5	02AE	52	45.2	61.2	
1	7	02ED	52	42.9	66.1	
1	9	032C	52	40.8	71.8	
1	11	036B	52	38.8	78.6	
1	13	03AA	52	37.1	86.8	
1	15	03E9	52	35.5	96.9	

(Continued)

MB91460S Series

Modulation Degree (k)	Random No (N)	CMPR [hex]	Baseclk [MHz]	Fmin [MHz]	Fmax [MHz]	Remarks
2	3	046E	52	45.2	61.2	
2	5	04AC	52	40.8	71.8	
2	7	04EA	52	37.1	86.8	
3	3	066D	52	42.9	66.1	
3	5	06AA	52	37.1	86.8	
4	3	086C	52	40.8	71.8	
5	3	0A6B	52	38.8	78.6	
6	3	0C6A	52	37.1	86.8	
7	3	0E69	52	35.5	96.9	
1	3	026F	48	44.2	52.5	
1	5	02AE	48	41.8	56.4	
1	7	02ED	48	39.6	60.9	
1	9	032C	48	37.7	66.1	
1	11	036B	48	35.9	72.3	
1	13	03AA	48	34.3	79.9	
1	15	03E9	48	32.8	89.1	
2	3	046E	48	41.8	56.4	
2	5	04AC	48	37.7	66.1	
2	7	04EA	48	34.3	79.9	
3	3	066D	48	39.6	60.9	
3	5	06AA	48	34.3	79.9	
4	3	086C	48	37.7	66.1	
5	3	0A6B	48	35.9	72.3	
6	3	0C6A	48	34.3	79.9	
7	3	0E69	48	32.8	89.1	
1	3	026F	44	40.6	48.1	
1	5	02AE	44	38.4	51.6	
1	7	02ED	44	36.4	55.7	
1	9	032C	44	34.6	60.4	
1	11	036B	44	33	66.1	
1	13	03AA	44	31.5	73	
1	15	03E9	44	30.1	81.4	
2	3	046E	44	38.4	51.6	
2	5	04AC	44	34.6	60.4	
2	7	04EA	44	31.5	73	

(Continued)

MB91460S Series

Modulation Degree (k)	Random No (N)	CMPR [hex]	Baseclk [MHz]	Fmin [MHz]	Fmax [MHz]	Remarks
2	9	0528	44	28.9	92.1	
3	3	066D	44	36.4	55.7	
3	5	06AA	44	31.5	73	
4	3	086C	44	34.6	60.4	
4	5	08A8	44	28.9	92.1	
5	3	0A6B	44	33	66.1	
6	3	0C6A	44	31.5	73	
7	3	0E69	44	30.1	81.4	
8	3	1068	44	28.9	92.1	
1	3	026F	40	37	43.6	
1	5	02AE	40	34.9	46.8	
1	7	02ED	40	33.1	50.5	
1	9	032C	40	31.5	54.8	
1	11	036B	40	30	59.9	
1	13	03AA	40	28.7	66.1	
1	15	03E9	40	27.4	73.7	
2	3	046E	40	34.9	46.8	
2	5	04AC	40	31.5	54.8	
2	7	04EA	40	28.7	66.1	
2	9	0528	40	26.3	83.3	
3	3	066D	40	33.1	50.5	
3	5	06AA	40	28.7	66.1	
3	7	06E7	40	25.3	95.8	
4	3	086C	40	31.5	54.8	
4	5	08A8	40	26.3	83.3	
5	3	0A6B	40	30	59.9	
6	3	0C6A	40	28.7	66.1	
7	3	0E69	40	27.4	73.7	
8	3	1068	40	26.3	83.3	
9	3	1267	40	25.3	95.8	
1	3	026F	36	33.3	39.2	
1	5	02AE	36	31.5	42	
1	7	02ED	36	29.9	45.3	
1	9	032C	36	28.4	49.2	
1	11	036B	36	27.1	53.8	

(Continued)

MB91460S Series

Modulation Degree (k)	Random No (N)	CMPR [hex]	Baseclk [MHz]	Fmin [MHz]	Fmax [MHz]	Remarks
1	13	03AA	36	25.8	59.3	
1	15	03E9	36	24.7	66.1	
2	3	046E	36	31.5	42	
2	5	04AC	36	28.4	49.2	
2	7	04EA	36	25.8	59.3	
2	9	0528	36	23.7	74.7	
3	3	066D	36	29.9	45.3	
3	5	06AA	36	25.8	59.3	
3	7	06E7	36	22.8	85.8	
4	3	086C	36	28.4	49.2	
4	5	08A8	36	23.7	74.7	
5	3	0A6B	36	27.1	53.8	
6	3	0C6A	36	25.8	59.3	
7	3	0E69	36	24.7	66.1	
8	3	1068	36	23.7	74.7	
9	3	1267	36	22.8	85.8	
1	3	026F	32	29.7	34.7	
1	5	02AE	32	28	37.3	
1	7	02ED	32	26.6	40.2	
1	9	032C	32	25.3	43.6	
1	11	036B	32	24.1	47.7	
1	13	03AA	32	23	52.5	
1	15	03E9	32	22	58.6	
2	3	046E	32	28	37.3	
2	5	04AC	32	25.3	43.6	
2	7	04EA	32	23	52.5	
2	9	0528	32	21.1	66.1	
2	11	0566	32	19.5	89.1	
3	3	066D	32	26.6	40.2	
3	5	06AA	32	23	52.5	
3	7	06E7	32	20.3	75.9	
4	3	086C	32	25.3	43.6	
4	5	08A8	32	21.1	66.1	
5	3	0A6B	32	24.1	47.7	
5	5	0AA6	32	19.5	89.1	

(Continued)

MB91460S Series

(Continued)

Modulation Degree (k)	Random No (N)	CMPR [hex]	Baseclk [MHz]	Fmin [MHz]	Fmax [MHz]	Remarks
6	3	0C6A	32	23	52.5	
7	3	0E69	32	22	58.6	
8	3	1068	32	21.1	66.1	
9	3	1267	32	20.3	75.9	
10	3	1466	32	19.5	89.1	

■ ELECTRICAL CHARACTERISTICS

1. Absolute maximum ratings

Parameter	Symbol	Rating		Unit	Remarks
		Min	Max		
Power supply slew rate	—	—	50	V/ms	
Power supply voltage 1*1	V _{DD5R}	- 0.3	+ 6.0	V	
Power supply voltage 2*1	V _{DD5}	- 0.3	+ 6.0	V	
Power supply voltage 3*1	V _{DD35}	- 0.3	+ 6.0	V	
Power supply voltage 4*1,7	V _{DDA}			V	
Relationship of the supply voltages	AV _{CC5}	V _{DD5} -0.3	V _{DD5} +0.3	V	At least one pin of the Ports 28 to 29 (ANn) is used as digital input or output
		V _{SS5} -0.3	V _{DD5} +0.3	V	All pins of the Ports 28 to 29 (ANn) follow the condition of V _{IA}
Analog power supply voltage*1	AV _{CC5}	- 0.3	+ 6.0	V	*2
Analog reference power supply voltage*1	AVRH5	- 0.3	+ 6.0	V	*2
Input voltage 1*1	V _{I1}	V _{SS5} - 0.3	V _{DD5} + 0.3	V	
Input voltage 2*1	V _{I2}	V _{SS5} - 0.3	V _{DD35} + 0.3	V	External bus
Analog pin input voltage*1	V _{IA}	AV _{SS} - 0.3	AV _{CC5} + 0.3	V	
Output voltage 1*1	V _{O1}	V _{SS5} - 0.3	V _{DD5} + 0.3	V	
Output voltage 2*1	V _{O2}	V _{SS5} - 0.3	V _{DD35} + 0.3	V	External bus
Maximum clamp current	I _{CLAMP}	- 4.0	+ 4.0	mA	*3
Total maximum clamp current	$\Sigma I_{CLAMP} $	—	20	mA	*3
“L” level maximum output current*4	I _{OL}	—	10	mA	
“L” level average output current*5	I _{OLAV}	—	8	mA	
“L” level total maximum output current	ΣI_{OL}	—	100	mA	
“L” level total average output current*6	ΣI_{OLAV}	—	50	mA	
“H” level maximum output current*4	I _{OH}	—	-10	mA	
“H” level average output current*5	I _{OHAV}	—	- 4	mA	
“H” level total maximum output current	ΣI_{OH}	—	- 100	mA	
“H” level total average output current*6	ΣI_{OHAV}	—	- 25	mA	

(Continued)

MB91460S Series

(Continued)

Parameter	Symbol	Rating		Unit	Remarks
		Min	Max		
Power consumption	P_D	—	1000	mW	
Operating temperature	T_A	- 40	+ 105	°C	
Storage temperature	T_{stg}	- 55	+ 150	°C	

*1 : The parameter is based on $V_{SS5} = AV_{SS5} = 0.0$ V.

*2 : AV_{CC5} and AV_{RH5} must not exceed $V_{DD5} + 0.3$ V.

*3 : •Use within recommended operating conditions.

•Use with DC voltage (current).

•+B signals are input signals that exceed the V_{DD5} voltage. +B signals should always be applied by connecting a limiting resistor between the +B signal and the microcontroller.

•The value of the limiting resistor should be set so that the current input to the microcontroller pin does not exceed the rated value at any time, either instantaneously or for an extended period, when the +B signal is input.

•Note that when the microcontroller drive current is low, such as in the low power consumption modes, the +B input potential can increase the potential at the power supply pin via a protective diode, possibly affecting other devices.

•Note that if the +B signal is input when the microcontroller is off (not fixed at 0 V), power is supplied through the +B input pin; therefore, the microcontroller may partially operate.

•Note that if the +B signal is input at power-on, since the power is supplied through the pin, the power-on reset may not function in the power supply voltage.

•Do not leave +B input pins open.

•Example of recommended circuit :

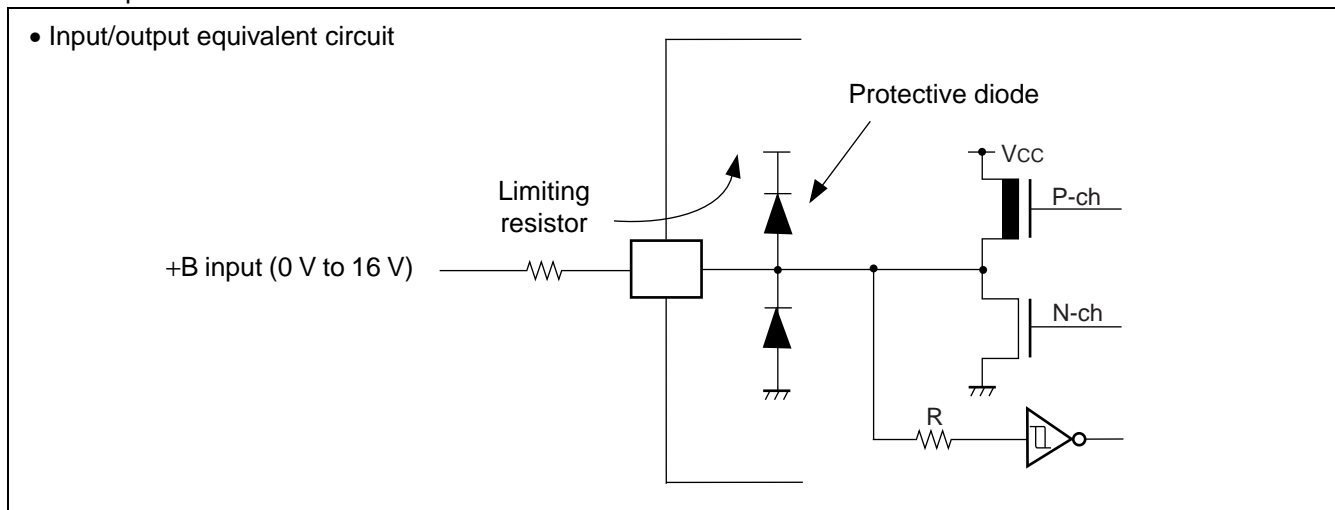

*4 : Maximum output current is defined as the value of the peak current flowing through any one of the corresponding pins.

*5 : Average output current is defined as the value of the average current flowing through any one of the corresponding pins for a 100 ms period.

*6 : Total average output current is defined as the value of the average current flowing through all of the corresponding pins for a 100 ms period.

WARNING: Semiconductor devices can be permanently damaged by application of stress (voltage, current, temperature, etc.) in excess of absolute maximum ratings. Do not exceed these ratings.

2. Recommended operating conditions

(V_{ss5} = AV_{ss5} = 0.0 V)

Parameter	Symbol	Value			Unit	Remarks
		Min	Typ	Max		
Power supply voltage	V _{DD5}	3.0	—	5.5	V	
	V _{DD5R}	3.0	—	5.5	V	Internal regulator
	V _{DD35}	3.0	—	5.5	V	External bus
	V _{DDA}	1.7	—	1.9	V	APIX®
	V _{PPA}	—	—	50	mV	V _{DDA} , V _{SSA} peak-peak supply noise
	AV _{CC5}	3.0	—	5.5	V	A/D converter
Smoothing capacitor	C _s	—	4.7	—	μF	Use a X7R ceramic capacitor or a capacitor that has similar frequency characteristics. Use a capacitor with a capacitance greater than C _s as the smoothing capacitor on the supply pin.
Power supply slew rate	—	—	—	50	V/ms	
Operating temperature	T _A	- 40	—	+ 105	°C	
Main Oscillation stabilization time		10	—	—	ms	
Lock-up time PLL (4 MHz ->16 ...100MHz)		—	—	0.6	ms	
ESD Protection (Human body model)	V _{surge}	2	—	—	kV	R _{discharge} = 1.5kΩ C _{discharge} = 100pF
RC Oscillator	f _{RC100kHz}	50	100	200	kHz	V _{DDCORE} ≥ 1.65V
	f _{RC2MHz}	1	2	4	MHz	

WARNING: The recommended operating conditions are required in order to ensure the normal operation of the semiconductor device. All of the device's electrical characteristics are warranted when the device is operated within these ranges.

Always use semiconductor devices within their recommended operating condition ranges.

Operation outside these ranges may adversely affect reliability and could result in device failure.

No warranty is made with respect to uses, operating conditions, or combinations not represented on the data sheet. Users considering application outside the listed conditions are advised to contact their representatives beforehand.

MB91460S Series

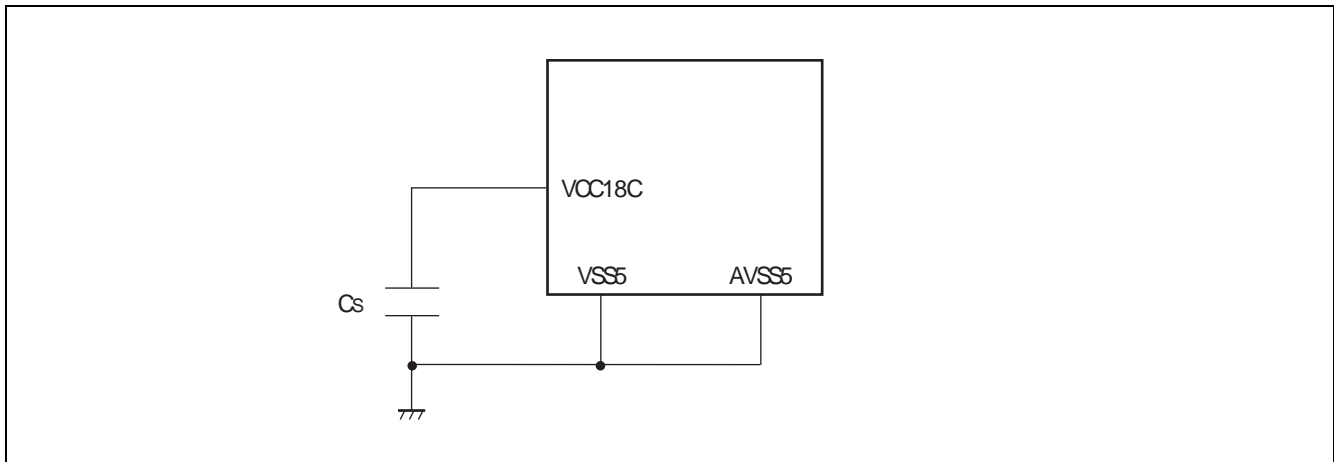

3. DC characteristics

Note: In the following tables, “V_{DD}” means V_{DD35} for pins of ext. bus or V_{DD5} for other pins.

(V_{DD5} = AV_{CC5} = 3.0 V to 5.5 V, V_{SS5} = AV_{SS5} = 0 V, T_A = -40 °C to +105 °C)

Parameter	Symbol	Pin name	Condition	Value			Unit	Remarks
				Min	Typ	Max		
Input “H” voltage	V _{IH}	—	Port inputs if CMOS Hysteresis 0.8/0.2 input is selected	0.8 × V _{DD}	—	V _{DD} + 0.3	V	CMOS hysteresis input
		—	Port inputs if CMOS Hysteresis 0.7/0.3 input is selected	0.7 × V _{DD}	—	V _{DD} + 0.3	V	4.5 V ≤ V _{DD} ≤ 5.5 V
				0.74 × V _{DD}	—	V _{DD} + 0.3	V	3 V ≤ V _{DD} < 4.5 V
		—	AUTOMOTIVE Hysteresis input is selected	0.8 × V _{DD}	—	V _{DD} + 0.3	V	
	—	Port inputs if TTL input is selected	2.0	—	V _{DD} + 0.3	V		
	V _{IHR}	INITX	—	0.8 × V _{DD}	—	V _{DD} + 0.3	V	INITX input pin (CMOS Hysteresis)
	V _{IHM}	MD2 to MD0	—	V _{DD} - 0.3	—	V _{DD} + 0.3	V	MDx input pins
	V _{IHX0S}	X0, X0A	—	2.5	—	V _{DD} + 0.3	V	External clock in “Oscillation mode”
V _{IHX0F}	X0	—	0.8 × V _{DD}	—	V _{DD} + 0.3	V	External clock in “Fast Clock Input mode”	
Input “L” voltage	V _{IL}	—	Port inputs if CMOS Hysteresis 0.8/0.2 input is selected	V _{SS5} - 0.3	—	0.2 × V _{DD}	V	
		—	Port inputs if CMOS Hysteresis 0.7/0.3 input is selected	V _{SS5} - 0.3	—	0.3 × V _{DD}	V	
				—	Port inputs if AUTOMOTIVE Hysteresis input is selected	V _{SS5} - 0.3	—	0.5 × V _{DD}
		V _{SS5} - 0.3	—			0.46 × V _{DD}	V	3 V ≤ V _{DD} < 4.5 V
	—	Port inputs if TTL input is selected	V _{SS5} - 0.3	—	0.8	V		
	V _{ILR}	INITX	—	V _{SS5} - 0.3	—	0.2 × V _{DD}	V	INITX input pin (CMOS Hysteresis)
	V _{ILM}	MD2 to MD0	—	V _{SS5} - 0.3	—	V _{SS5} + 0.3	V	MDx input pins
	V _{ILXDS}	X0, X0A	—	V _{SS5} - 0.3	—	0.5	V	External clock in “Oscillation mode”

(Continued)

MB91460S Series

($V_{DD5} = AV_{CC5} = 3.0\text{ V to }5.5\text{ V}$, $V_{SS5} = AV_{SS5} = 0\text{ V}$, $T_A = -40\text{ }^\circ\text{C to }+105\text{ }^\circ\text{C}$)

Parameter	Symbol	Pin name	Condition	Value			Unit	Remarks
				Min	Typ	Max		
Input "L" voltage	V_{ILXDF}	X0	—	$V_{SS5} - 0.3$	—	$0.2 \times V_{DD}$	V	External clock in "Fast Clock Input mode"
Output "H" voltage	V_{OH2}	Normal outputs	$4.5\text{V} \leq V_{DD} \leq 5.5\text{V}$, $I_{OH} = -2\text{mA}$	$V_{DD} - 0.5$	—	—	V	Driving strength set to 2 mA
			$3.0\text{V} \leq V_{DD} < 4.5\text{V}$, $I_{OH} = -1.6\text{mA}$					
	V_{OH5}	Normal outputs	$4.5\text{V} \leq V_{DD} \leq 5.5\text{V}$, $I_{OH} = -5\text{mA}$	$V_{DD} - 0.5$	—	—	V	Driving strength set to 5 mA
			$3.0\text{V} \leq V_{DD} < 4.5\text{V}$, $I_{OH} = -3\text{mA}$					
	V_{OH3}	I ² C outputs	$3.0\text{V} \leq V_{DD} \leq 5.5\text{V}$, $I_{OH} = -3\text{mA}$	$V_{DD} - 0.5$	—	—	V	
	V_{OH30}	High current outputs	$4.5\text{V} \leq V_{DD} \leq 5.5\text{V}$, $T_A = -40\text{ }^\circ\text{C}$, $I_{OH} = -40\text{mA}$	$V_{DD} - 0.5$	—	—	V	Driving strength set to 30mA
			$4.5\text{V} \leq V_{DD} \leq 5.5\text{V}$, $I_{OH} = -30\text{mA}$					
			$3.0\text{V} \leq V_{DD} < 4.5\text{V}$, $I_{OH} = -20\text{mA}$					
Output "L" voltage	V_{OL2}	Normal outputs	$4.5\text{V} \leq V_{DD} \leq 5.5\text{V}$, $I_{OL} = +2\text{mA}$	—	—	0.4	V	Driving strength set to 2 mA
			$3.0\text{V} \leq V_{DD} < 4.5\text{V}$, $I_{OL} = +1.6\text{mA}$					
	V_{OL5}	Normal outputs	$4.5\text{V} \leq V_{DD} \leq 5.5\text{V}$, $I_{OL} = +5\text{mA}$	—	—	0.4	V	Driving strength set to 5 mA
			$3.0\text{V} \leq V_{DD} < 4.5\text{V}$, $I_{OL} = +3\text{mA}$					
	V_{OL3}	I ² C outputs	$3.0\text{V} \leq V_{DD} \leq 5.5\text{V}$, $I_{OL} = +3\text{mA}$	—	—	0.4	V	
	V_{OL30}	High current outputs	$4.5\text{V} \leq V_{DD} \leq 5.5\text{V}$, $T_A = -40\text{ }^\circ\text{C}$, $I_{OL} = +40\text{mA}$	—	—	0.5	V	Driving strength set to 30mA
			$4.5\text{V} \leq V_{DD} \leq 5.5\text{V}$, $I_{OL} = +30\text{mA}$					
			$3.0\text{V} \leq V_{DD} < 4.5\text{V}$, $I_{OL} = +20\text{mA}$					

(Continued)

MB91460S Series

($V_{DD5} = AV_{CC5} = 3.0\text{ V to }5.5\text{ V}$, $V_{SS5} = AV_{SS5} = 0\text{ V}$, $T_A = -40\text{ }^\circ\text{C to }+105\text{ }^\circ\text{C}$)

Parameter	Symbol	Pin name	Condition	Value			Unit	Remarks
				Min	Typ	Max		
Input leakage current	I_{IL}	Pnn_m*1	$3.0\text{V} \leq V_{DD} \leq 5.5\text{V}$ $V_{SS5} < V_I < V_{DD}$ $T_A = 25\text{ }^\circ\text{C}$	-1	—	+1	μA	
			$3.0\text{V} \leq V_{DD} \leq 5.5\text{V}$ $V_{SS5} < V_I < V_{DD}$ $T_A = 105\text{ }^\circ\text{C}$	-3	—	+3		
Analog input leakage current	I_{AIN}	ADIN	$3.0\text{V} \leq V_{DD} \leq 5.5\text{V}$ $AV_{SS5} \leq V_I \leq AV_{CC5}$ $T_A = 25\text{ }^\circ\text{C}$	-1	—	+1	μA	
			$3.0\text{V} \leq V_{DD} \leq 5.5\text{V}$ $AV_{SS5} \leq V_I \leq AV_{CC5}$ $T_A = 105\text{ }^\circ\text{C}$	-3	—	+3		
Sum input leakage	ΣI_L	Pnn_m ALARM	$V_{DD5} \geq V_{IN} \geq V_{SS5}$ $AV_{CC5}, AV_{RH5} \geq V_{IN} \geq AV_{SS5}$ $\Sigma (1 \text{ to } n) [\max(I_{L-Hi} , I_{L-Li})]$ (n = number of IO = 133 GPIO + 1 ALARM)	—	13	130	μA	
Pull-up resistance	R_{UP}	Pnn_m*1, INITX	$3.0\text{V} \leq V_{DD} \leq 3.6\text{V}$	40	100	160	$\text{k}\Omega$	
			$4.5\text{V} \leq V_{DD} \leq 5.5\text{V}$	25	50	100		
Pull-down resistance	R_{DOWN}	Pnn_m*1	$3.0\text{V} \leq V_{DD} \leq 3.6\text{V}$	40	100	160	$\text{k}\Omega$	
			$4.5\text{V} \leq V_{DD} \leq 5.5\text{V}$	25	50	100		
APIX® terminal resistance	R_{TERM}	SDINM SDINP SD-OUTM SD-OUT-MP	—	35	—	65	Ω	

(Continued)

MB91460S Series

(Continued)

($V_{DD5} = AV_{CC5} = 3.0 \text{ V to } 5.5 \text{ V}$, $V_{SS5} = AV_{SS5} = 0 \text{ V}$, $T_A = -40 \text{ }^\circ\text{C to } +105 \text{ }^\circ\text{C}$)

Parameter	Symbol	Pin name	Condition	Value			Unit	Remarks
				Min	Typ	Max		
Power supply current	I _{CC}	V _{DD5R}	—	—	125	155	mA	(Conditions at MB91F467SA) CLKB: 100 MHz CLKP: 50 MHz CLKT: 50 MHz CLKCAN: 40 MHz Code fetch from Flash
		V _{DDA}	—	—	12	60		APIX®
	I _{CCH}	V _{DD5R}	T _A = +25 °C	—	30	150	μA	At stop mode *2
			T _A = +105 °C	—	400	2000	μA	
			T _A = +25 °C	—	100	500	μA	RTC : 4 MHz mode *2
			T _A = +105 °C	—	500	2400	μA	
			T _A = +25 °C	—	50	250	μA	RTC : 100 kHz mode *2
			T _A = +105 °C	—	450	2200	μA	
	V _{DDA}	—	—	10	50	μA	APIX® power-down	
	I _{LVE}	V _{DD5}	—	—	70	150	μA	External low voltage detection
	I _{LVI}	V _{DD5R}	—	—	50	100	μA	Internal low voltage detection
	I _{OSC}	V _{DD5}	—	—	250	500	μA	Main clock (4 MHz)
			—	—	20	40	μA	Sub clock (32 kHz)
Input capacitance	C _{IN}	All except V _{DD5} , V _{DD5R} , V _{SS5} , AV _{CC5} , AV _{SS} , V _{DDA} , V _{SSA} ,	f = 1 MHz	—	5	15	pF	

*1 Pnn_m includes all pins unless the pins, which include analog inputs.

*2 Main regulator OFF, sub regulator set to 1.2V, Low voltage detection disabled.

4. A/D converter characteristics

($V_{DD5} = AV_{CC5} = 3.0\text{ V to }5.5\text{ V}$, $V_{SS5} = AV_{SS5} = 0\text{ V}$, $T_A = -40\text{ }^\circ\text{C to }+105\text{ }^\circ\text{C}$)

Parameter	Symbol	Pin name	Value			Unit	Remarks
			Min	Typ	Max		
Resolution	—	—	—	—	10	bit	
Total error	—	—	-3	—	+3	LSB	
Nonlinearity error	—	—	-2.5	—	+2.5	LSB	
Differential nonlinearity error	—	—	-1.9	—	+1.9	LSB	
Zero reading voltage	V_{OT}	ANn	AVRL-1.5 LSB	AVRL + 0.5 LSB	AVRL + 2.5 LSB	V	
Full scale reading voltage	V_{FST}	ANn	AVRH-3.5 LSB	AVRH-1.5 LSB	AVRH + 0.5 LSB	V	
Compare time	T_{comp}	—	1.0	—	16,500	μs	$4.5\text{ V} \leq AV_{CC5} \leq 5.5\text{ V}$
			2.0	—	—	μs	$3.0\text{ V} \leq AV_{CC5} < 4.5\text{ V}$
Sampling time	T_{samp}	—	0.4	—	—	μs	$4.5\text{ V} \leq AV_{CC5} \leq 5.5\text{ V}$, $R_{EXT} < 2\text{ k}\Omega$
			1.0	—	—	μs	$3.0\text{ V} \leq AV_{CC5} < 4.5\text{ V}$, $R_{EXT} < 1\text{ k}\Omega$
Conversion time	T_{conv}	—	1.4	—	—	μs	$4.5\text{ V} \leq AV_{CC5} \leq 5.5\text{ V}$
			3.0	—	—	μs	$3.0\text{ V} \leq AV_{CC5} < 4.5\text{ V}$
Input capacitance	C_{IN}	ANn	—	—	11	pF	
Input resistance	R_{IN}	ANn	—	—	2.6	k Ω	$4.5\text{ V} \leq AV_{CC5} \leq 5.5\text{ V}$
			—	—	12.1	k Ω	$3.0\text{ V} \leq AV_{CC5} < 4.5\text{ V}$
Analog input leakage current	I_{AIN}	ANn	-1	—	+1	μA	$T_A = +25\text{ }^\circ\text{C}$
			-3	—	+3	μA	$T_A = +105\text{ }^\circ\text{C}$
Analog input voltage range	V_{AIN}	ANn	AVRL	—	AVRH	V	
Offset between input channels	—	ANn	—	—	4	LSB	

(Continued)

Note : The accuracy gets worse as $AVRH - AVRL$ becomes smaller

MB91460S Series

(Continued)

Parameter	Symbol	Pin name	Value			Unit	Remarks
			Min	Typ	Max		
Reference voltage range	AVRH	AVRH5	$0.75 \times AV_{CC5}$	—	AV_{CC5}	V	
	AVRL	AVSS5	AV_{SS5}	—	$AV_{CC5} \times 0.25$	V	
Power supply current per ADC macro *3	I _A	AVCC5	—	2.5	5	mA	A/D Converter active
	I _{AH}	AVCC5	—	—	5	μA	A/D Converter not operated *1
Reference voltage current per ADC macro *3	I _R	AVRH5	—	0.7	1	mA	A/D Converter active
	I _{RH}	AVRH5	—	—	5	μA	A/D Converter not operated *2

*1 : Supply current at AVCC5, if A/D converter and ALARM comparator are not operating, (V_{DD5} = AVCC5 = AVRH = 5.0 V)

*2 : Input current at AVRH5, if A/D converter is not operating, (V_{DD5} = AVCC5 = AVRH = 5.0 V)

*3 : The current consumption per ADC macro is given here. On devices having more than one A/D converter, the current values have to be multiplied by the number of macros.

Sampling Time Calculation

$$T_{\text{samp}} = (2.6 \text{ k}\Omega + R_{\text{EXT}}) \times 11 \text{ pF} \times 7; \text{ for } 4.5 \text{ V} \leq AV_{CC5} \leq 5.5 \text{ V}$$

$$T_{\text{samp}} = (12.1 \text{ k}\Omega + R_{\text{EXT}}) \times 11 \text{ pF} \times 7; \text{ for } 3.0 \text{ V} \leq AV_{CC5} < 4.5 \text{ V}$$

Conversion Time Calculation

$$T_{\text{conv}} = T_{\text{samp}} + T_{\text{comp}}$$

Definition of A/D converter terms

- Resolution
Analog variation that is recognizable by the A/D converter.
- Nonlinearity error
Deviation between actual conversion characteristics and a straight line connecting the zero transition point (00 0000 0000_B ↔ 00 0000 0001_B) and the full scale transition point (11 1111 1110_B ↔ 11 1111 1111_B).
- Differential nonlinearity error
Deviation of the input voltage from the ideal value that is required to change the output code by 1 LSB.
- Total error
This error indicates the difference between actual and theoretical values, including the zero transition error, full scale transition error, and nonlinearity error.

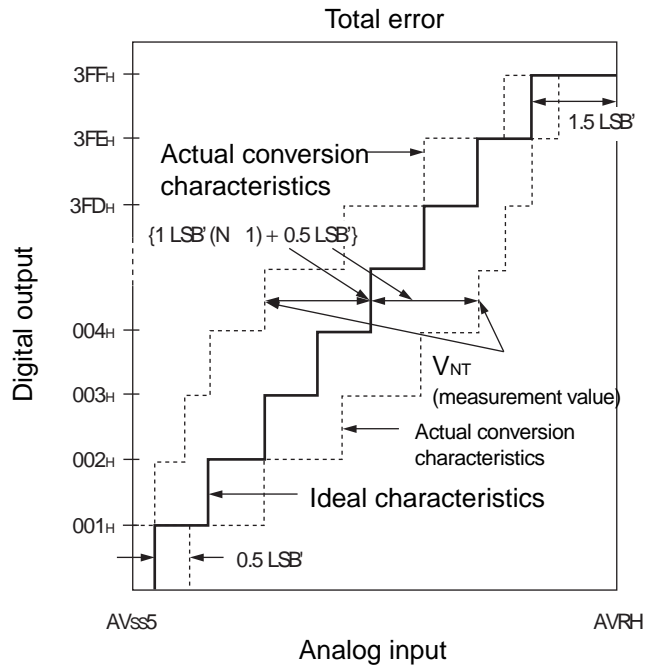

$$1\text{LSB}' (\text{ideal value}) = \frac{\text{AVRH} - \text{AV}_{\text{ss5}}}{1024} \text{ [V]}$$

$$\text{Total error of digital output } N = \frac{V_{\text{NT}} - \{1\text{LSB}' \times (N - 1) + 0.5\text{LSB}'\}}{1\text{LSB}'}$$

N : A/D converter digital output value

V_{OT'} (ideal value) = AV_{ss5} + 0.5LSB' [V]

V_{FST'} (ideal value) = AV_{RH} - 1.5LSB' [V]

V_{NT} : Voltage at which the digital output changes from (N + 1)_H to N_H

(Continued)

(Continued)

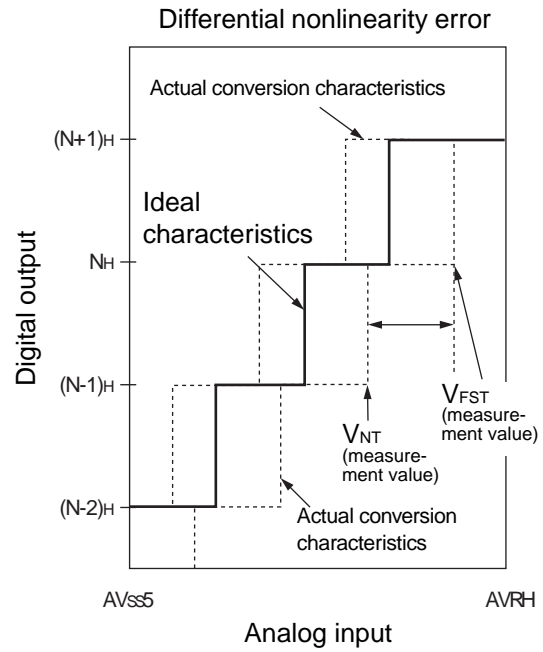
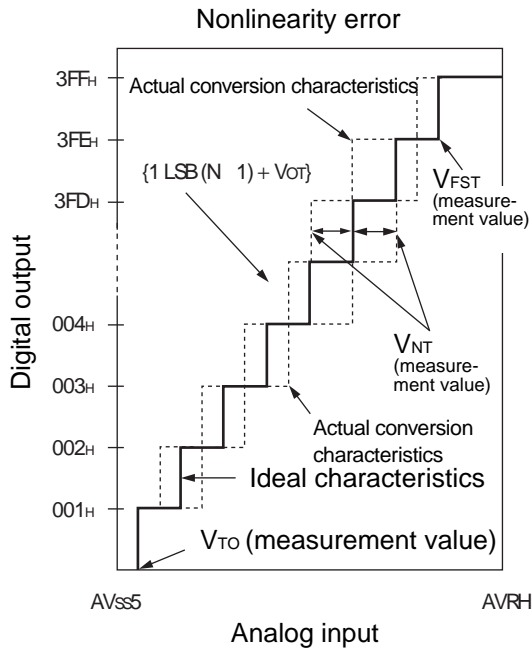

$$\text{Nonlinearity error of digital output } N = \frac{V_{NT} - \{1\text{LSB} \times (N - 1) + V_{OT}\}}{1\text{LSB}} \text{ [LSB]}$$

$$\text{Differential nonlinearity error of digital output } N = \frac{V_{(N+1)T} - V_{NT}}{1\text{LSB}} - 1 \text{ [LSB]}$$

$$1\text{LSB} = \frac{V_{FST} - V_{OT}}{1022} \text{ [V]}$$

N : A/D converter digital output value

V_{OT} : Voltage at which the digital output changes from 000_H to 001_H.

V_{FST} : Voltage at which the digital output changes from 3FE_H to 3FF_H.

5. Alarm comparator characteristics

Parameter	Symbol	Pin name	Value			Unit	Remarks
			Min	Typ	Max		
Power supply current	I _{A5ALMF}	AV _{CC5}	—	25	40	μA	Alarm comparator enabled in fast mode (one channel)
	I _{A5ALMS}		—	7	10	μA	Alarm comparator enabled in fast mode (one channel)
	I _{A5ALMH}		—	—	5	μA	Alarm comparator disabled
ALARM pin input current	I _{ALIN}	ALARM	-1	—	+1	μA	T _A = +25 °C
			-3	—	+3		T _A = +105 °C
ALARM pin input voltage range	V _{ALIN}		0	—	AV _{CC5}	V	
Alarm upper limit voltage	V _{IAH}		AV _{CC5} × 0.78 - 3%	AV _{CC5} × 0.78	AV _{CC5} × 0.78 + 3%	V	
Alarm lower limit voltage	V _{IAL}		AV _{CC5} × 0.36 - 5%	AV _{CC5} × 0.36	AV _{CC5} × 0.36 + 5%	V	
Alarm hysteresis voltage	V _{IAHYS}		50	—	250	mV	
Alarm input resistance	R _{IN}		5	—	—	MΩ	
Comparison time	t _{COMP} F		—	0.1	0.2	μs	ACSR.MD=1
	t _{COMP} S		—	1	2	μs	ACSR.MD=0

MB91460S Series

6. FLASH memory program/erase characteristics

6.1. MB91F467SA

($T_A = 25^\circ\text{C}$, $V_{CC} = 5.0\text{V}$)

Parameter	Value			Unit	Remarks
	Min	Typ	Max		
Sector erase time	-	0.5	2.0	s	Erase programming time not included
Chip erase time	-	n*0.5	n*2.0	s	n is the number of Flash sector of the device
Word (16-bit width) programming time	-	6	100	μs	System overhead time not included
Programme/Erase cycle	10 000			cycle	
Flash data retention time	20			year	*1

*1: This value was converted from the results of evaluating the reliability of the technology (using Arrhenius equation to convert high temperature measurements into normalized value at 85°C)

7. AC characteristics

7.1. Clock timing

($V_{DD5} = 3.0\text{ V to } 5.5\text{ V}$, $V_{SS5} = AV_{SS5} = 0\text{ V}$, $T_A = -40\text{ }^\circ\text{C to } +105\text{ }^\circ\text{C}$)

Parameter	Symbol	Pin name	Value			Unit	Condition
			Min	Typ	Max		
Clock frequency	f_c	X0 X1	3.5	4	16	MHz	Opposite phase external supply or crystal
		X0A X1A	32	32.768	100	kHz	

- Clock timing condition

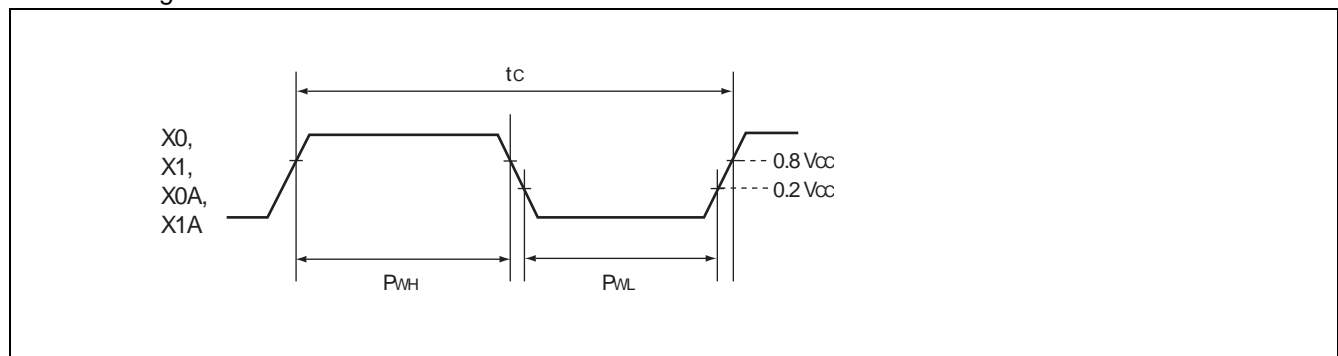

MB91460S Series

7.2. Reset input ratings

($V_{DD5} = 3.0\text{ V to }5.5\text{ V}$, $V_{SS5} = AV_{SS5} = 0\text{ V}$, $T_A = -40\text{ }^{\circ}\text{C to }+105\text{ }^{\circ}\text{C}$)

Parameter	Symbol	Pin name	Condition	Value		Unit
				Min	Max	
INITX input time (at power-on)	t_{INTL}	INITX	—	8	—	ms
INITX input time (other than the above)				20	—	μs

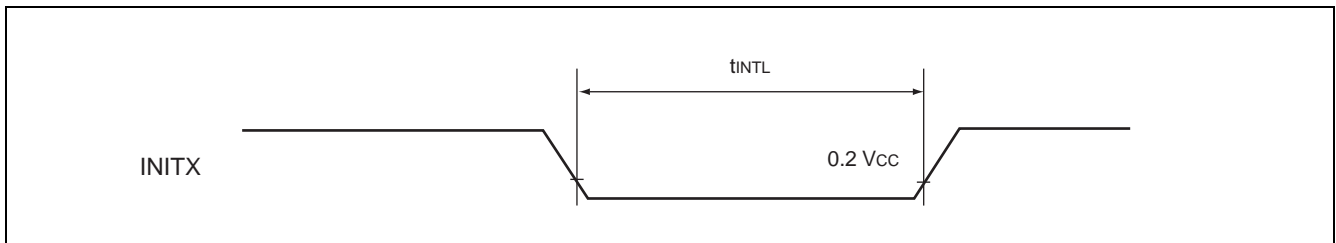

7.3. LIN-USART Timings at V_{DD5} = 3.0 to 5.5 V

- Conditions during AC measurements
- All AC tests were measured under the following conditions:
 - - I_{Odrive} = 5 mA
 - - V_{DD5} = 3.0 V to 5.5 V, I_{load} = 3 mA
 - - V_{SS5} = 0 V
 - - T_a = -40 °C to +105 °C
 - - C_i = 50 pF (load capacity value of pins when testing)
 - - VOL = 0.2 x V_{DD5},
 - - VOH = 0.8 x V_{DD5}
 - - EPILR = 0, PILR = 1 (Automotive Level = worst case)

(V_{DD5} = 3.0 V to 5.5 V, V_{SS5} = AV_{SS5} = 0 V, T_A = -40 °C to +105 °C)

Parameter	Symbol	Pin name	Condition	V _{DD5} = 3.0 V to 4.5 V		V _{DD5} = 4.5 V to 5.5 V		Unit
				Min	Max	Min	Max	
Serial clock cycle time	t _{SCYCI}	SCKn	Internal clock operation (master mode)	4 t _{CLKP}	—	4 t _{CLKP}	—	ns
SCK ↓ → SOT delay time	t _{SLOVI}	SCKn SOTn		- 30	30	- 20	20	ns
SOT → SCK ↓ delay time	t _{OVSHI}	SCKn SOTn		m × t _{CLKP} - 30*	—	m × t _{CLKP} - 20*	—	ns
Valid SIN → SCK ↑ setup time	t _{IVSHI}	SCKn SINn		t _{CLKP} + 55	—	t _{CLKP} + 45	—	ns
SCK ↑ → valid SIN hold time	t _{SHIXI}	SCKn SINn		0	—	0	—	ns
Serial clock "H" pulse width	t _{SHSLE}	SCKn	External clock operation (slave mode)	t _{CLKP} + 10	—	t _{CLKP} + 10	—	ns
Serial clock "L" pulse width	t _{LSHE}	SCKn		t _{CLKP} + 10	—	t _{CLKP} + 10	—	ns
SCK ↓ → SOT delay time	t _{SLOVE}	SCKn SOTn		—	2 t _{CLKP} + 55	—	2 t _{CLKP} + 45	ns
Valid SIN → SCK ↑ setup time	t _{IVSHE}	SCKn SINn		10	—	10	—	ns
SCK ↑ → valid SIN hold time	t _{SHIXE}	SCKn SINn		t _{CLKP} + 10	—	t _{CLKP} + 10	—	ns
SCK rising time	t _{FE}	SCKn		—	20	—	20	ns
SCK falling time	t _{RE}	SCKn		—	20	—	20	ns

- * : Parameter m depends on t_{SCYCI} and can be calculated as :
- if t_{SCYCI} = 2*k*t_{CLKP}, then m = k, where k is an integer > 2
 - if t_{SCYCI} = (2*k + 1)*t_{CLKP}, then m = k + 1, where k is an integer > 1

Notes : • The above values are AC characteristics for CLK synchronous mode.
 • t_{CLKP} is the cycle time of the peripheral clock.

MB91460S Series

- Internal clock mode (master mode)

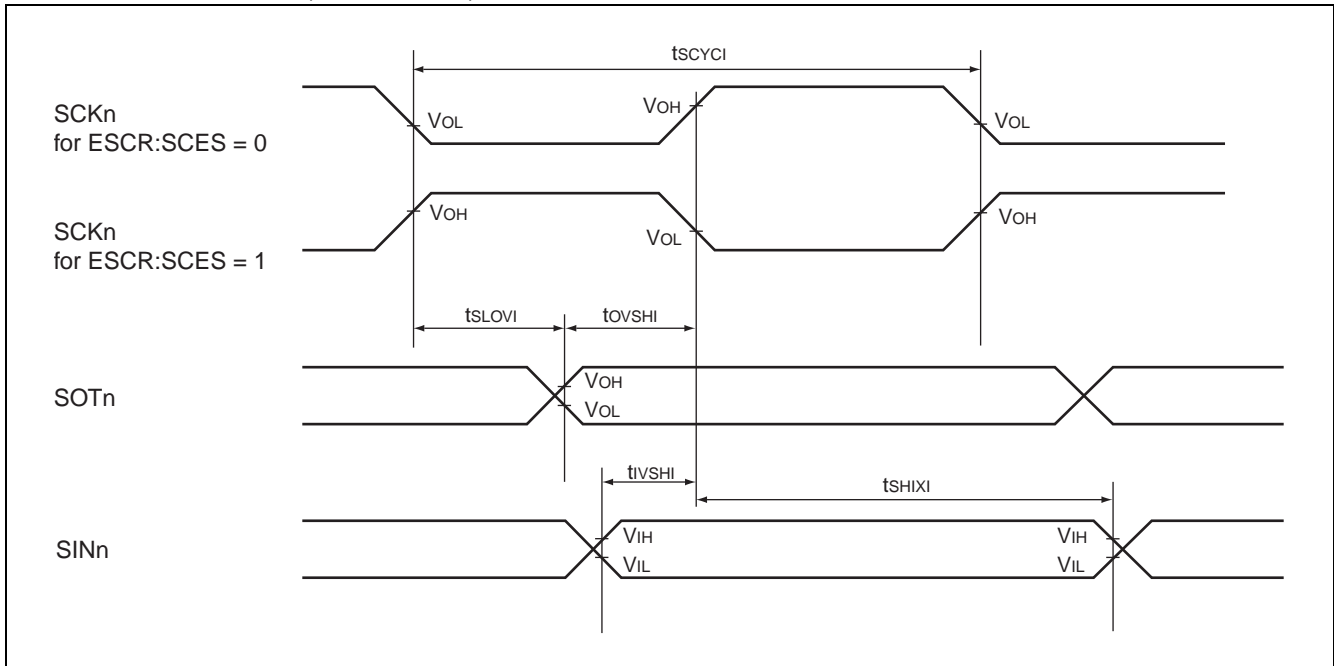

- External clock mode (slave mode)

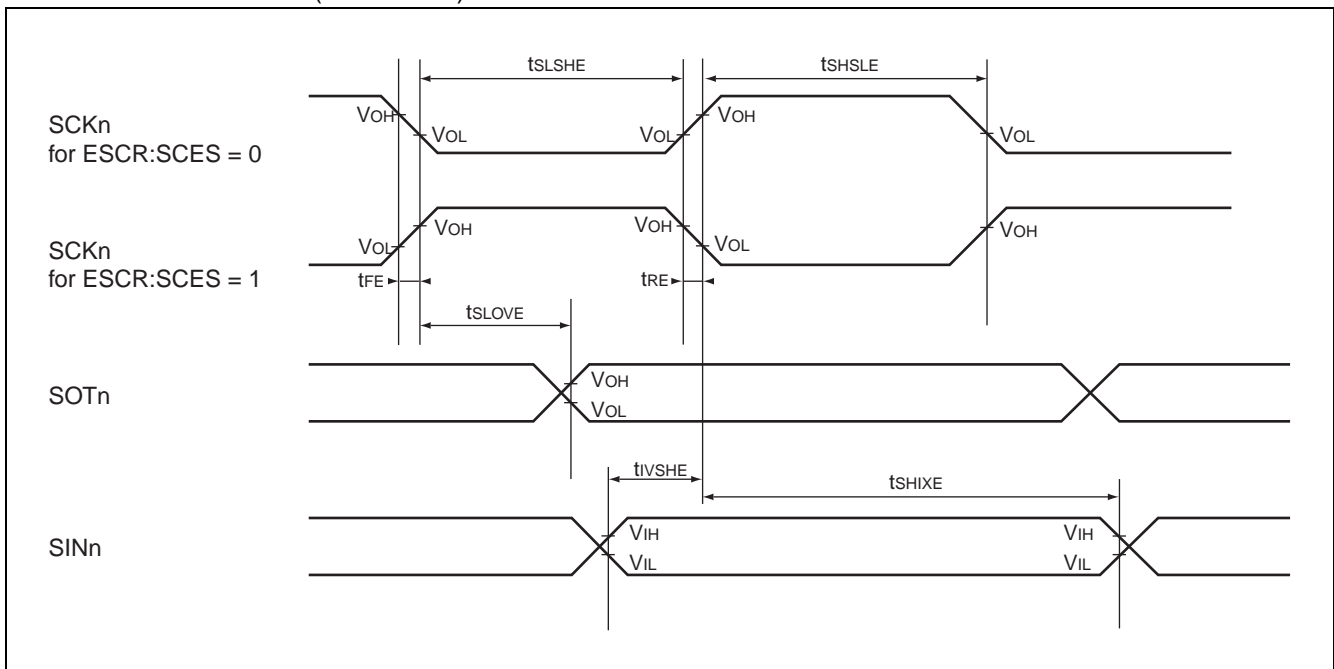

7.4. I²C AC Timings at V_{DD5} = 3.0 to 5.5 V

- Conditions during AC measurements

All AC tests were measured under the following conditions:

- I_{Odrive} = 3 mA
- V_{DD5} = 3.0 V to 5.5 V, I_{load} = 3 mA
- V_{SS5} = 0 V
- T_A = -40 °C to +105 °C
- C_i = 50 pF
- VOL = 0.3 × V_{DD5},
VOH = 0.7 × V_{DD5}
- EPILR = 0, PILR = 0 (CMOS Hysteresis 0.3 × V_{DD5}/0.7 × V_{DD5})

Fast mode:

(V_{DD5} = 3.5 V to 5.5 V, V_{SS5} = AV_{SS5} = 0 V, T_A = -40 °C to +105 °C)

Parameter	Symbol	Pin name	Value		Unit	Remark
			Min	Max		
SCL clock frequency	f _{SCL}	SCLn	0	400	kHz	
Hold time (repeated) START condition. After this period, the first clock pulse is generated	t _{HD,STA}	SCLn, SDAn	0.6	—	μs	
LOW period of the SCL clock	t _{LOW}	SCLn	1.3	—	μs	
HIGH period of the SCL clock	t _{HIGH}	SCLn	0.6	—	μs	
Setup time for a repeated START condition	t _{SU,STA}	SCLn, SDAn	0.6	—	μs	
Data hold time for I ² C-bus devices	t _{HD,DAT}	SCLn, SDAn	0	0.9	μs	
Data setup time	t _{SU,DAT}	SCLn, SDAn	100	—	ns	
Rise time of both SDA and SCL signals	t _r	SCLn, SDAn	20 + 0.1Cb	300	ns	
Fall time of both SDA and SCL signals	t _f	SCLn, SDAn	20 + 0.1Cb	300	ns	
Setup time for STOP condition	t _{SU,STO}	SCLn, SDAn	0.6	—	μs	
Bus free time between a STOP and START condition	t _{BUF}	SCLn, SDAn	1.3	—	μs	
Capacitive load for each bus line	C _b	SCLn, SDAn	—	400	pF	
Pulse width of spike suppressed by input filter	t _{SP}	SCLn, SDAn	0	(1..1.5) × t _{CLKP}	ns	*1

*1 The noise filter will suppress single spikes with a pulse width of 0ns and between (1 to 1.5) cycles of peripheral clock, depending on the phase relationship between I²C signals (SDA, SCL) and peripheral clock.

Note: t_{CLKP} is the cycle time of the peripheral clock.

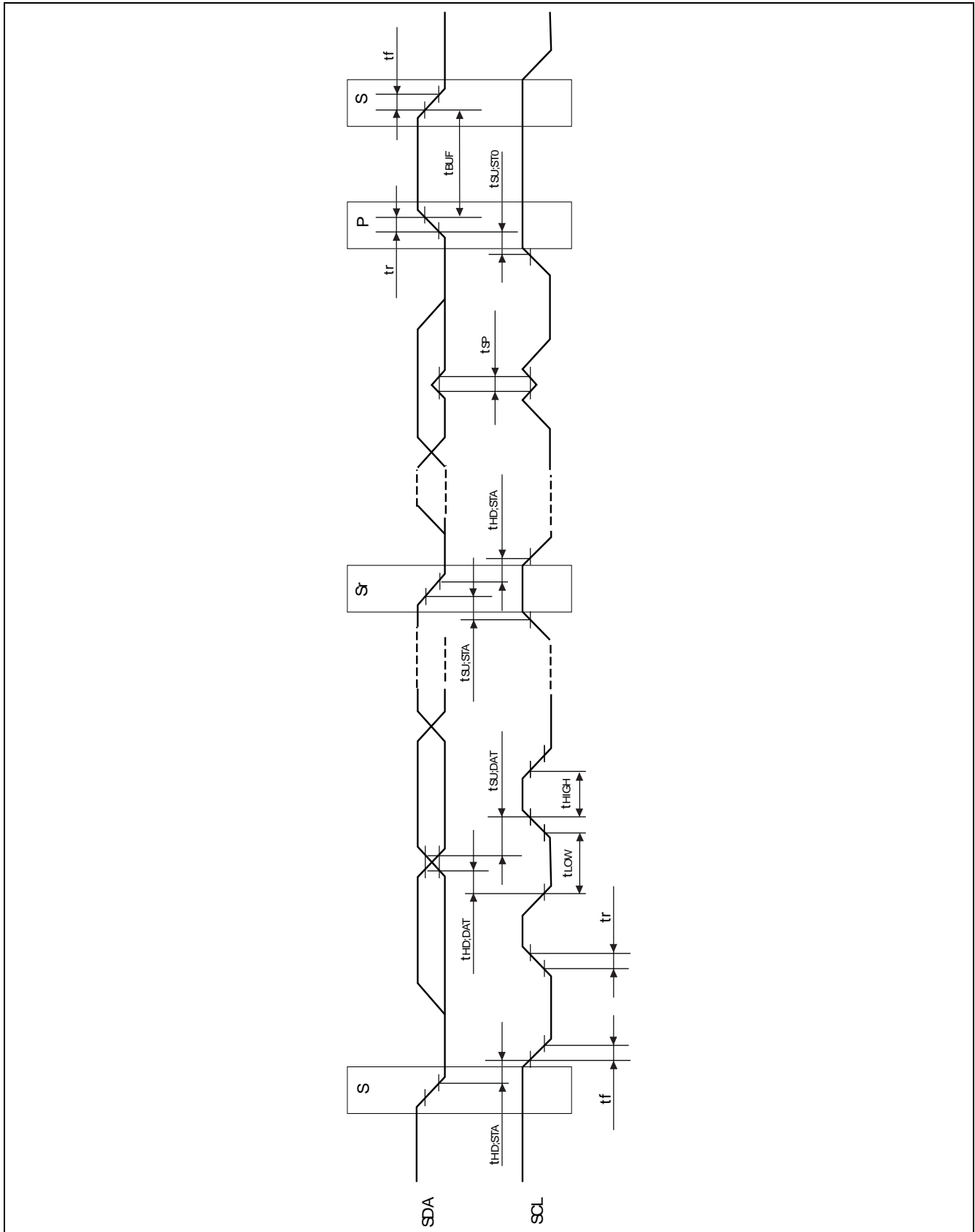

7.5. Free-run timer clock

($V_{DD5} = 3.0\text{ V to } 5.5\text{ V}$, $V_{SS5} = AV_{SS5} = 0\text{ V}$, $T_A = -40\text{ }^\circ\text{C to } +105\text{ }^\circ\text{C}$)

Parameter	Symbol	Pin name	Condition	Value		Unit
				Min	Max	
Input pulse width	t_{TIWH} t_{TIWL}	CKn	—	$4t_{CLKP}$	—	ns

Note : t_{CLKP} is the cycle time of the peripheral clock.

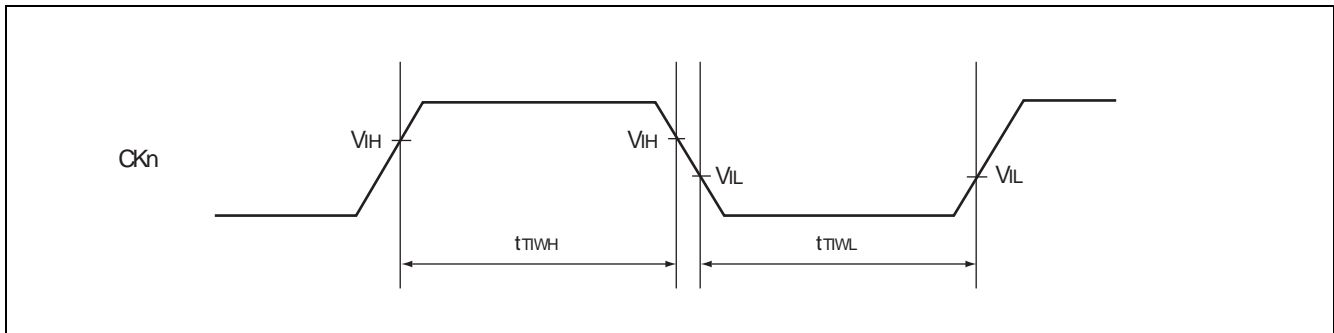

7.6. Trigger input timing

($V_{DD5} = 3.0\text{ V to } 5.5\text{ V}$, $V_{SS5} = AV_{SS5} = 0\text{ V}$, $T_A = -40\text{ }^\circ\text{C to } +105\text{ }^\circ\text{C}$)

Parameter	Symbol	Pin name	Condition	Value		Unit
				Min	Max	
Input capture input trigger	t_{INP}	ICUn	—	$5t_{CLKP}$	—	ns
A/D converter trigger	t_{ATGX}	ATGX	—	$5t_{CLKP}$	—	ns

Note : t_{CLKP} is the cycle time of the peripheral clock.

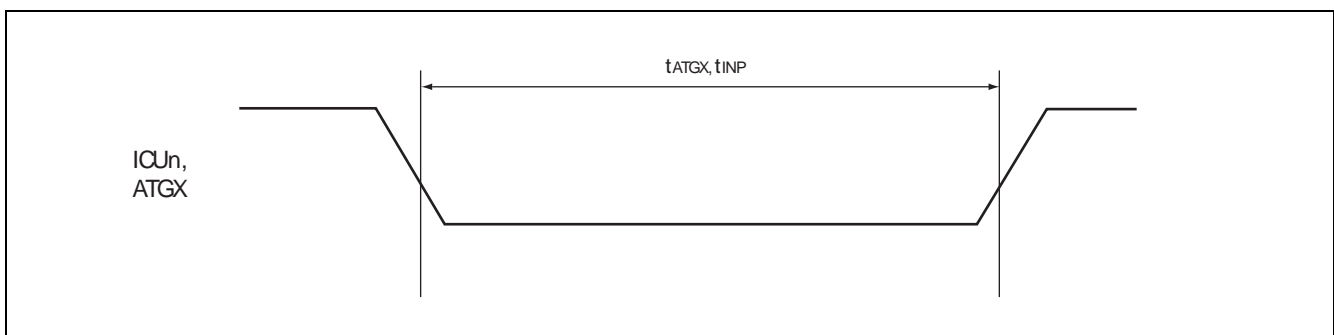

MB91460S Series

7.7. External Bus AC Timings at $V_{DD35} = 4.5$ to 5.5 V

- Conditions during AC measurements
All AC tests were measured under the following conditions:
 - $I_{Odrive} = 5$ mA
 - $V_{DD35} = 4.5$ V to 5.5 V, $I_{load} = 5$ mA
 - $V_{SS5} = 0$ V
 - $T_a = -40$ °C to $+105$ °C
 - $C_i = 50$ pF
 - $V_{OL} = 0.2 \times V_{DD35}$,
 $V_{OH} = 0.8 \times V_{DD35}$
 - EPILR = 0, PILR = 1 (Automotive Level = worst case)

7.7.1. Basic Timing

($V_{DD35} = 4.5$ V to 5.5 V, $V_{SS5} = AV_{SS5} = 0$ V, $T_a = -40$ °C to $+105$ °C)

Parameter	Symbol	Pin name	Value		Unit
			Min	Max	
SYSCLK	t_{CLCH}	SYSCLK	$1/2 \times t_{CLKT} - 1$	$1/2 \times t_{CLKT} + 1$	ns
	t_{CHCL}		$1/2 \times t_{CLKT} - 1$	$1/2 \times t_{CLKT} + 1$	ns
SYSCLK ↓ to CSXn delay time	t_{CLCSL}	SYSCLK CSXn	—	5	ns
	t_{CLCSH}		—	5	ns
SYSCLK ↑ to CSXn delay time (Addr → CS delay)	t_{CHCSL}		3	7	ns
SYSCLK ↓ to ASX delay time	t_{CLASL}	SYSCLK ASX	—	5	ns
	t_{CLASH}		—	5	ns
SYSCLK ↓ to Address valid delay time	t_{CLAV}	SYSCLK A23 to A0	—	7	ns

Note : t_{CLKT} is the cycle time of the external bus clock.

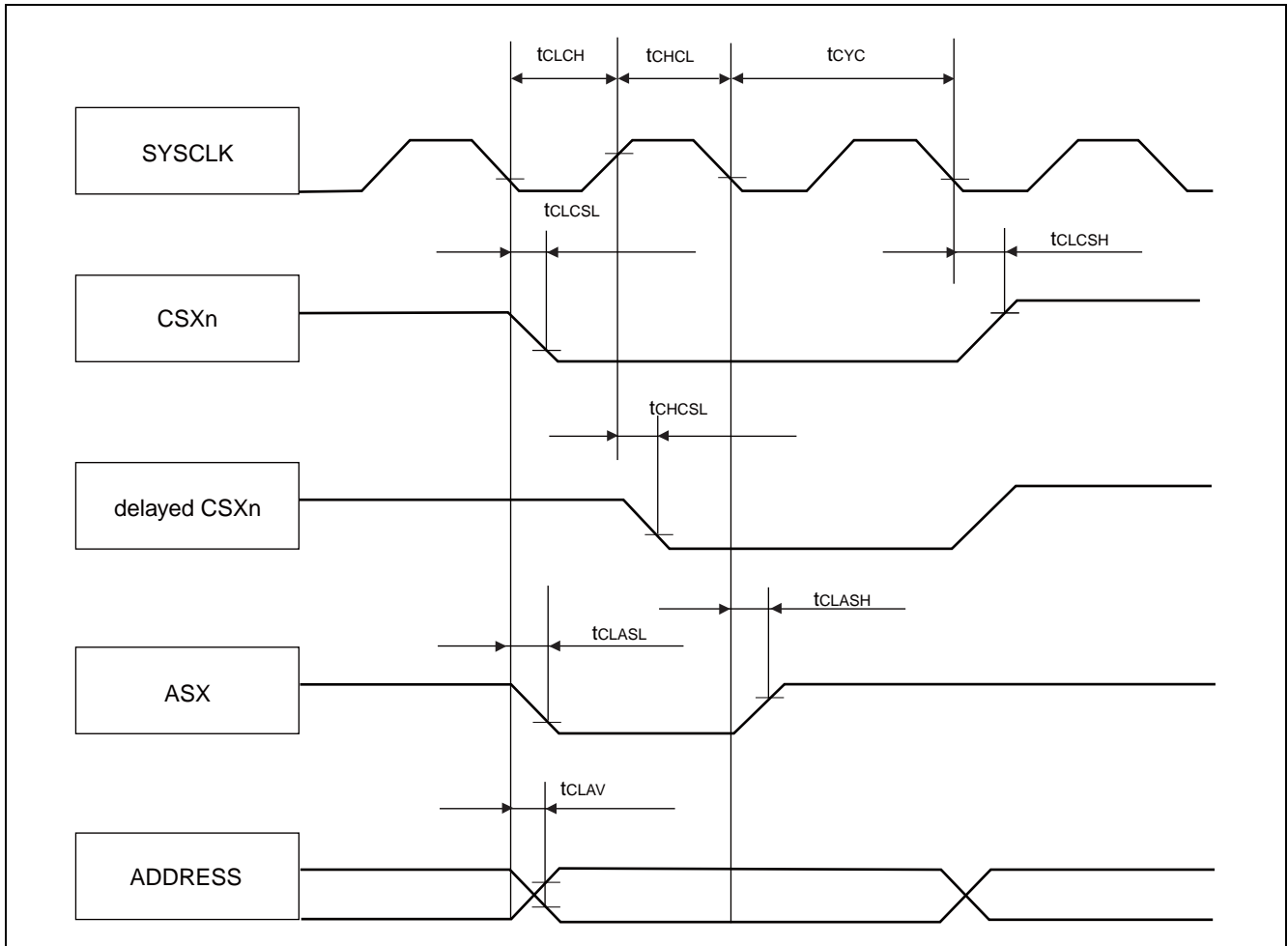

MB91460S Series

7.7.2. Synchronous/Asynchronous read access

($V_{DD35} = 4.5\text{ V to }5.5\text{ V}$, $V_{SS5} = AV_{SS5} = 0\text{ V}$, $T_A = -40\text{ }^{\circ}\text{C to }+105\text{ }^{\circ}\text{C}$)

Parameter	Symbol	Pin name	Value		Unit
			Min	Max	
SYSCLK \uparrow to RDX delay time	TCHRL	SYSCLK RDX	2	5	ns
	TCHRH		2	5	ns
Data valid to RDX \uparrow setup time	TDSRH	RDX D31 to D16	12	—	ns
RDX \uparrow to Data valid hold time	TRHDX	RDX D31 to D16	0	—	ns
SYSCLK \downarrow to WRXn (as byte enable) delay time	TCLWRL	SYSCLK WRXn	—	5	ns
	TCLWRH		2	—	ns
SYSCLK \downarrow to CSXn delay time	TCLCSL	SYSCLK CSXn	—	5	ns
	TCLCSH		—	5	ns

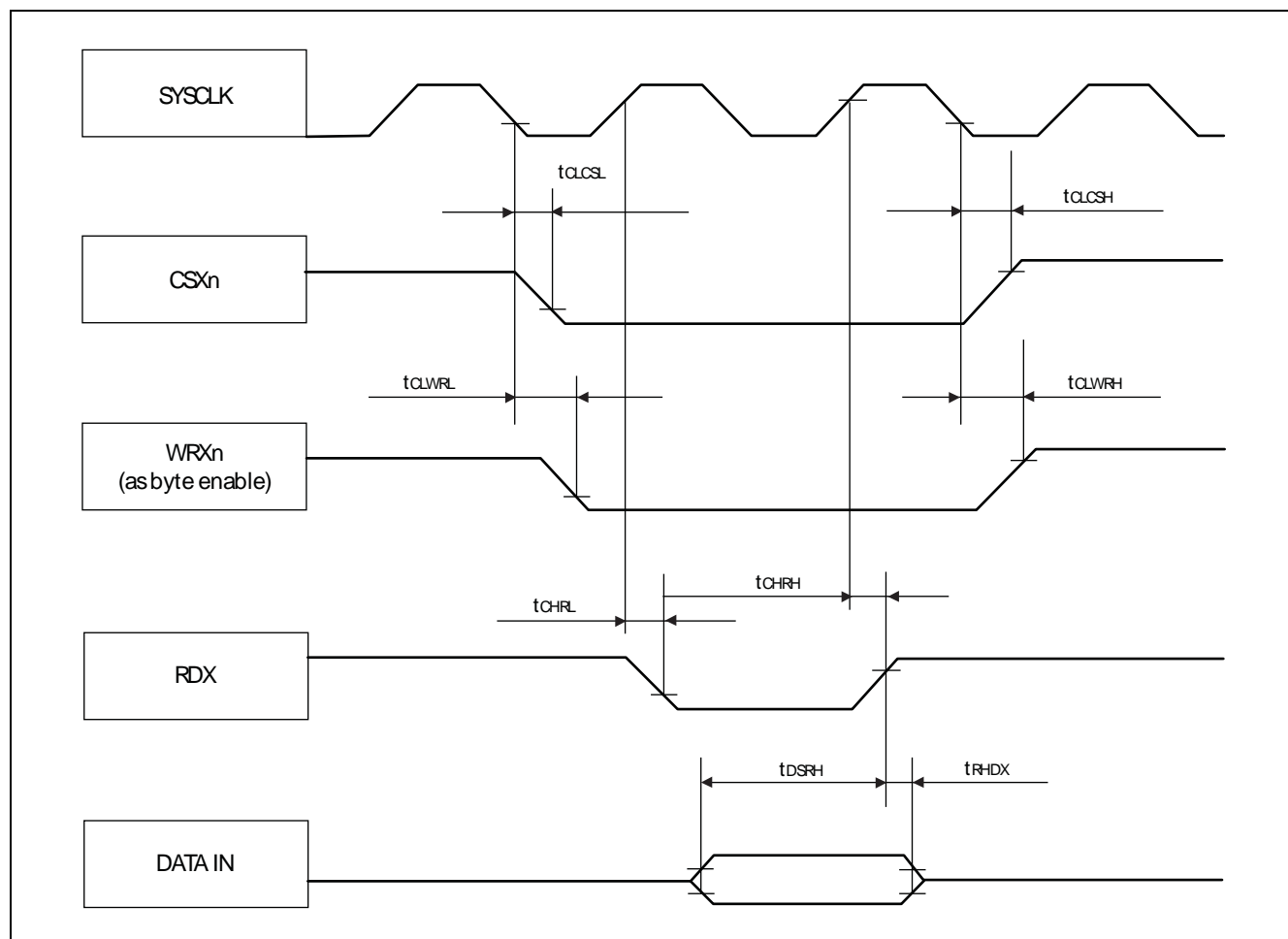

7.7.3. Synchronous write access - byte control type

($V_{DD35} = 4.5\text{ V to }5.5\text{ V}$, $V_{SS5} = AV_{SS5} = 0\text{ V}$, $T_A = -40\text{ }^\circ\text{C to }+105\text{ }^\circ\text{C}$)

Parameter	Symbol	Pin name	Value		Unit
			Min	Max	
SYSCLK ↓ to WEX delay time	TCLWL	SYSCLK WEX	—	5	ns
	TCLWH		2	—	ns
Data valid to WEX ↓ setup time	TDSWL	WEX D31 to D16	-1	—	ns
WEX ↑ to Data valid hold time	TWHDH	WEX D31 to D16	$t_{CLKT} - 1$	—	ns
SYSCLK ↓ to WRXn (as byte enable) delay time	TCLWRL	SYSCLK WRXn	—	5	ns
	TCLWRH		2	—	ns
SYSCLK ↓ to CSXn delay time	TCLCSL	SYSCLK CSXn	—	5	ns
	TCLCSH		—	5	ns

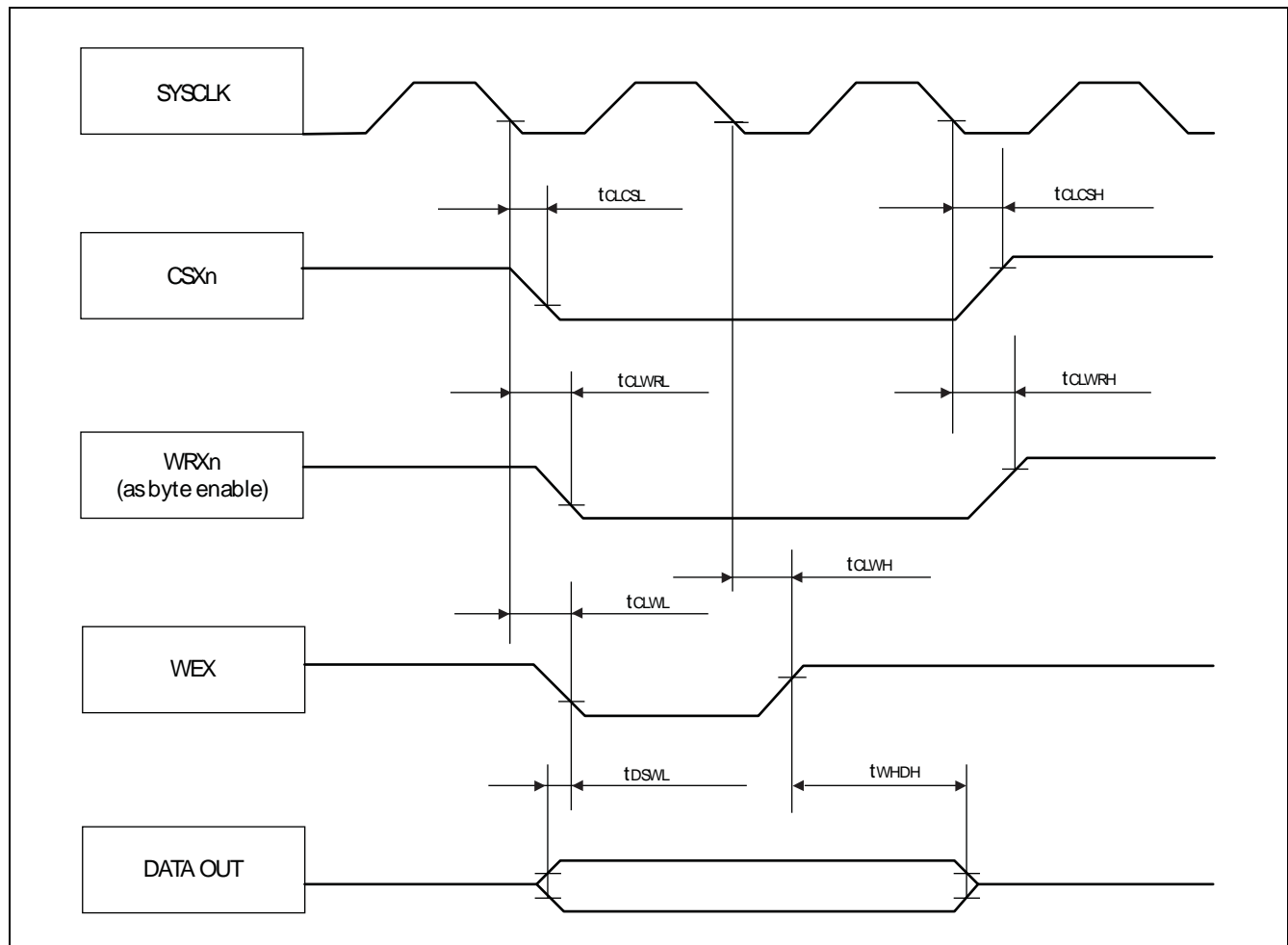

MB91460S Series

7.7.4. Synchronous write access - no byte control type

($V_{DD35} = 4.5\text{ V to }5.5\text{ V}$, $V_{SS5} = AV_{SS5} = 0\text{ V}$, $T_A = -40\text{ }^{\circ}\text{C to }+105\text{ }^{\circ}\text{C}$)

Parameter	Symbol	Pin name	Value		Unit
			Min	Max	
SYSCLK \downarrow to WRXn delay time	TCLWRL	SYSCLK WRXn	—	5	ns
	TCLWRH		2	—	ns
Data valid to WRXn \downarrow setup time	TDSWRL	WRXn D31 to D16	-1	—	ns
WRXn \uparrow to Data valid hold time	TWRHDH	WRXn D31 to D16	$t_{CLKT} - 1$	—	ns
SYSCLK \downarrow to CSXn delay time	TCLCSL	SYSCLK CSXn	—	5	ns
	TCLCSH		—	5	ns

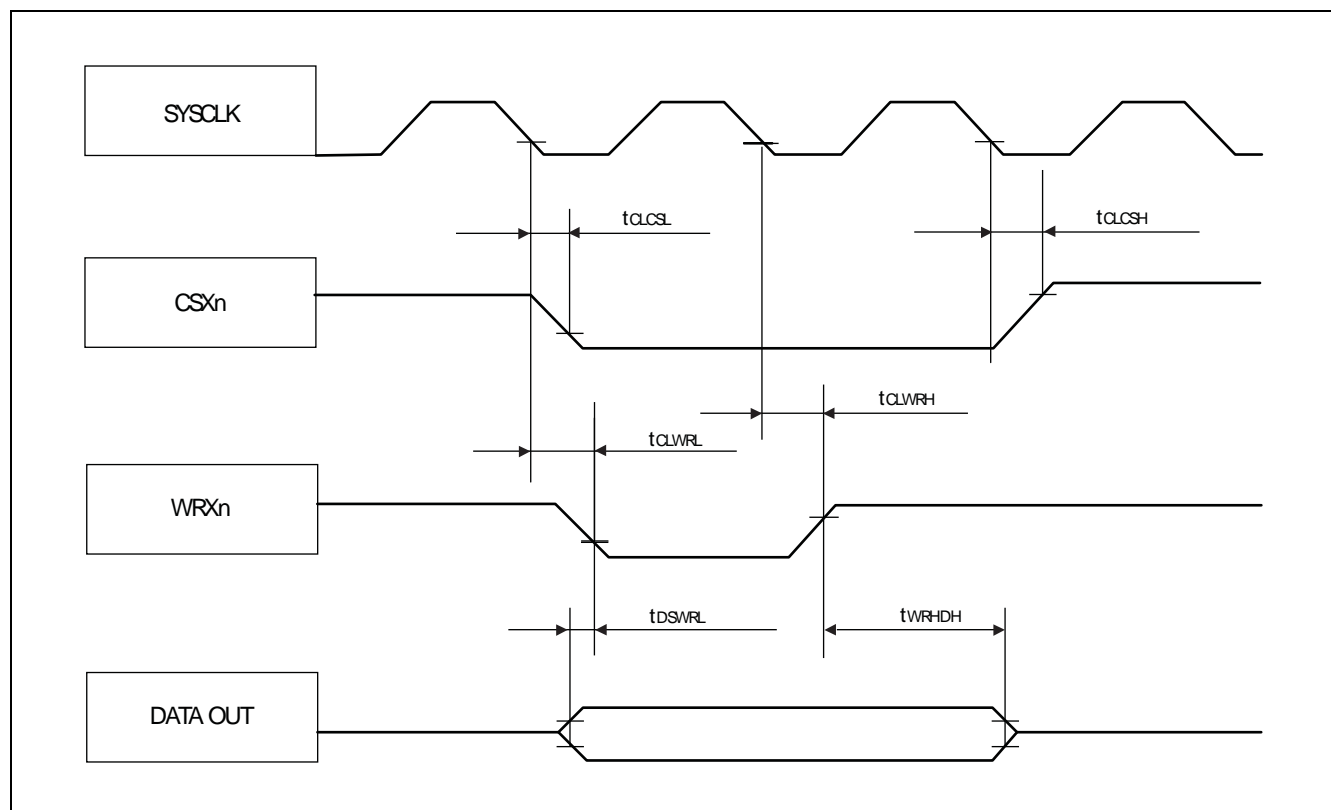

MB91460S Series

7.7.6. Asynchronous write access - no byte control type

($V_{DD35} = 4.5\text{ V to }5.5\text{ V}$, $V_{SS5} = AV_{SS5} = 0\text{ V}$, $T_A = -40\text{ }^\circ\text{C to }+105\text{ }^\circ\text{C}$)

Parameter	Symbol	Pin name	Value		Unit
			Min	Max	
WRXn ↓ to WRXn ↑ pulse width	TWRLWRH	WRXn	$t_{CLKT} - 1$	—	ns
Data valid to WRXn ↓ setup time	TDSWRL	WRXn D31 to D16	$1/2 \times t_{CLKT} - 1$	—	ns
WRXn ↑ to Data valid hold time	TWRHDH	WRXn D31 to D16	$1/2 \times t_{CLKT} - 1$	—	ns
WRXn to CSXn delay time	TCLWRL	WRXn CSXn	—	$1/2 \times t_{CLKT} + 1$	ns
	TWRHCH	WRXn CSXn	$1/2 \times t_{CLKT} - 1$	—	ns

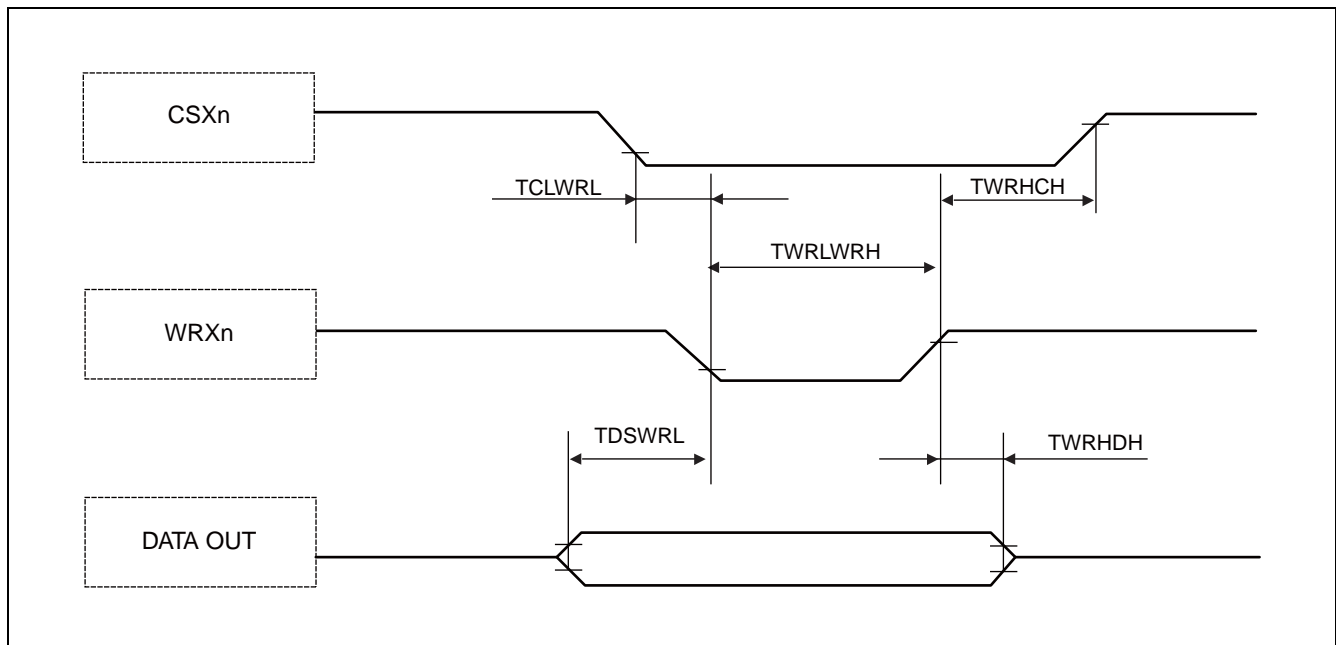

7.7.7. RDY waitcycle insertion

($V_{DD35} = 4.5 \text{ V to } 5.5 \text{ V}$, $V_{SS5} = AV_{SS5} = 0 \text{ V}$, $T_A = -40 \text{ }^\circ\text{C to } +105 \text{ }^\circ\text{C}$)

Parameter	Symbol	Pin name	Value		Unit
			Min	Max	
RDY setup time	TRDYS	SYSCLK RDY	8	—	ns
RDY hold time	TRDYH	SYSCLK RDY	0	—	ns

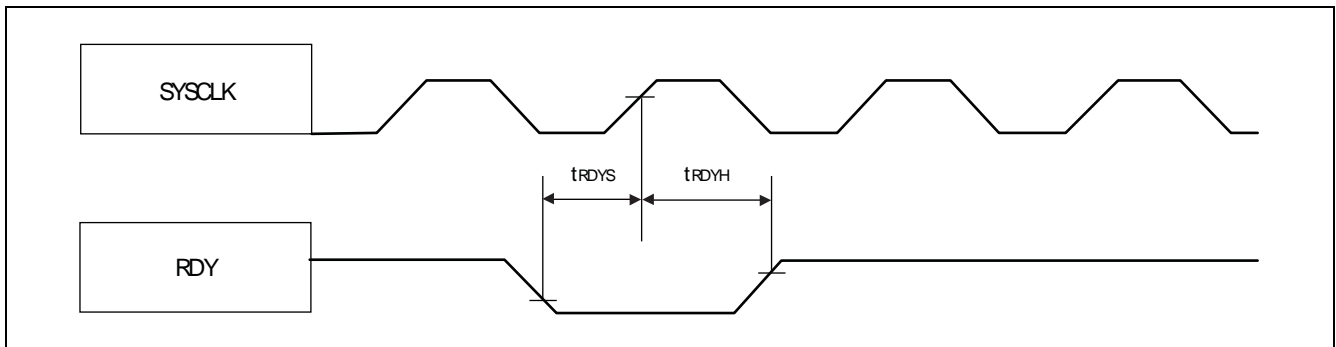

MB91460S Series

7.8. External Bus AC Timings at $V_{DD35} = 3.0$ to 4.5 V

- Conditions during AC measurements
- All AC tests were measured under the following conditions:
- $I_{Odrive} = 5$ mA
 - $V_{DD35} = 3.0$ V to 4.5 V, $I_{load} = 3$ mA
 - $V_{SS5} = 0$ V
 - $T_a = -40$ °C to $+105$ °C
 - $C_i = 50$ pF
 - $V_{OL} = 0.2 \times V_{DD35}$,
 $V_{OH} = 0.8 \times V_{DD35}$
 - $EPILR = 0$, $PILR = 1$ (Automotive Level = worst case)

7.8.1. Basic Timing

($V_{DD35} = 3.0$ V to 4.5 V, $V_{SS5} = AV_{SS5} = 0$ V, $T_a = -40$ °C to $+105$ °C)

Parameter	Symbol	Pin name	Value		Unit
			Min	Max	
SYSCLK	TCLCH	SYSCLK	$1/2 \times t_{CLKT}$	$1/2 \times t_{CLKT} + 2$	ns
	TCHCL		$1/2 \times t_{CLKT} - 2$	$1/2 \times t_{CLKT}$	ns
SYSCLK ↓ to CSXn delay time	TCLCSL	SYSCLK CSXn	—	11	ns
	TCLCSH		—	7	ns
SYSCLK ↑ to CSXn delay time (Addr → CS delay)	TCHCSL		2	6	ns
SYSCLK ↓ to ASX delay time	TCLASL	SYSCLK ASX	—	6	ns
	TCLASH		—	7	ns
SYSCLK ↓ to Address valid delay time	TCLAV	SYSCLK A23 to A0	—	13	ns

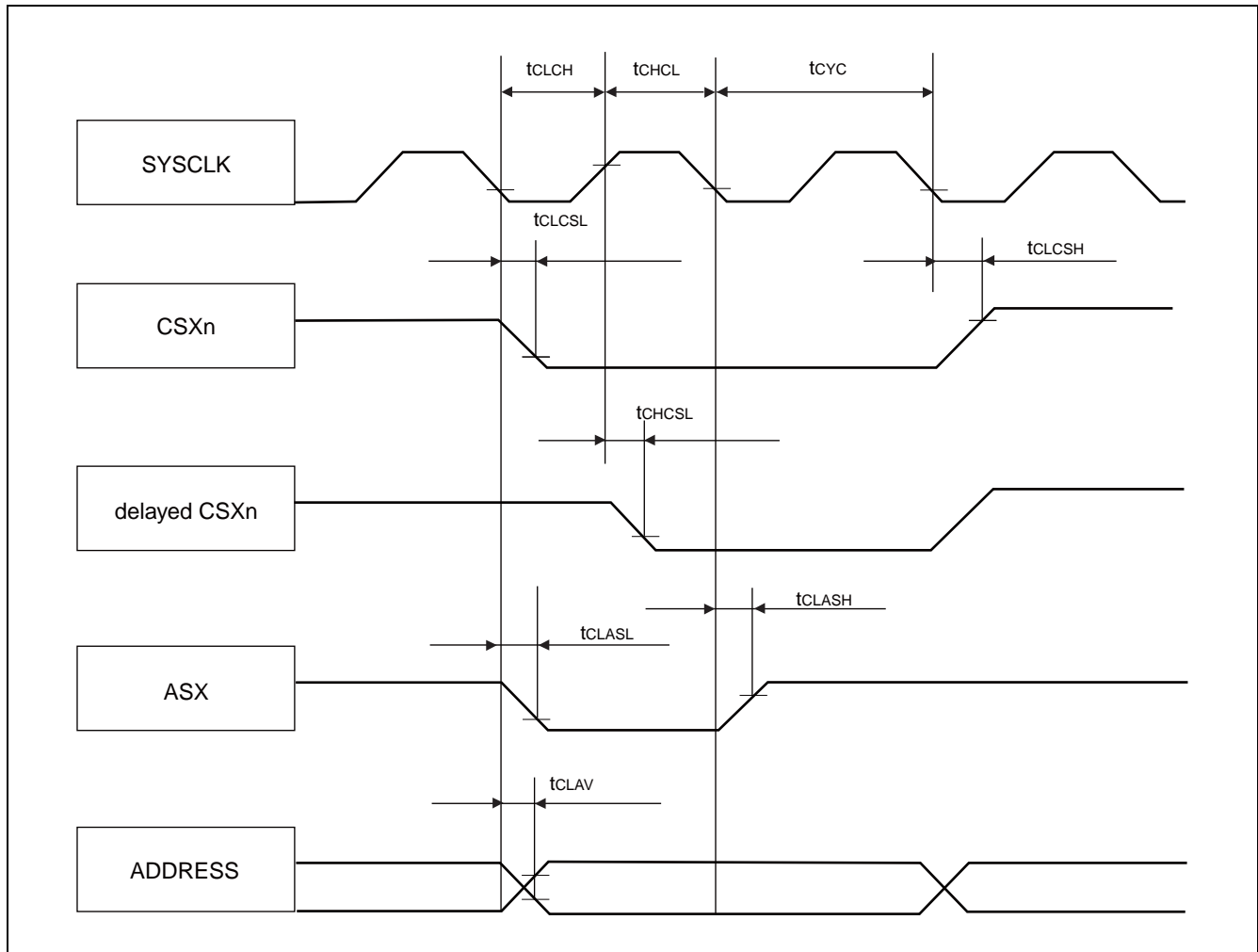

MB91460S Series

7.8.2. Synchronous/Asynchronous read access

($V_{DD35} = 3.0\text{ V to }4.5\text{ V}$, $V_{SS5} = AV_{SS5} = 0\text{ V}$, $T_A = -40\text{ }^{\circ}\text{C to }+105\text{ }^{\circ}\text{C}$)

Parameter	Symbol	Pin name	Value		Unit
			Min	Max	
SYSCLK \uparrow to RDX delay time	TCHRL	SYSCLK	1	4	ns
	TCHRH	RDX	2	6	ns
Data valid to RDX \uparrow setup time	TDSRH	RDX D31 to D16	16	—	ns
RDX \uparrow to Data valid hold time	TRHDX	RDX D31 to D16	0	—	ns
SYSCLK \downarrow to WRXn (as byte enable) delay time	TCLWRL	SYSCLK	—	6	ns
	TCLWRH	WRXn	3	—	ns
SYSCLK \downarrow to CSXn delay time	TCLCSL	SYSCLK	—	11	ns
	TCLCSH	CSXn	—	7	ns

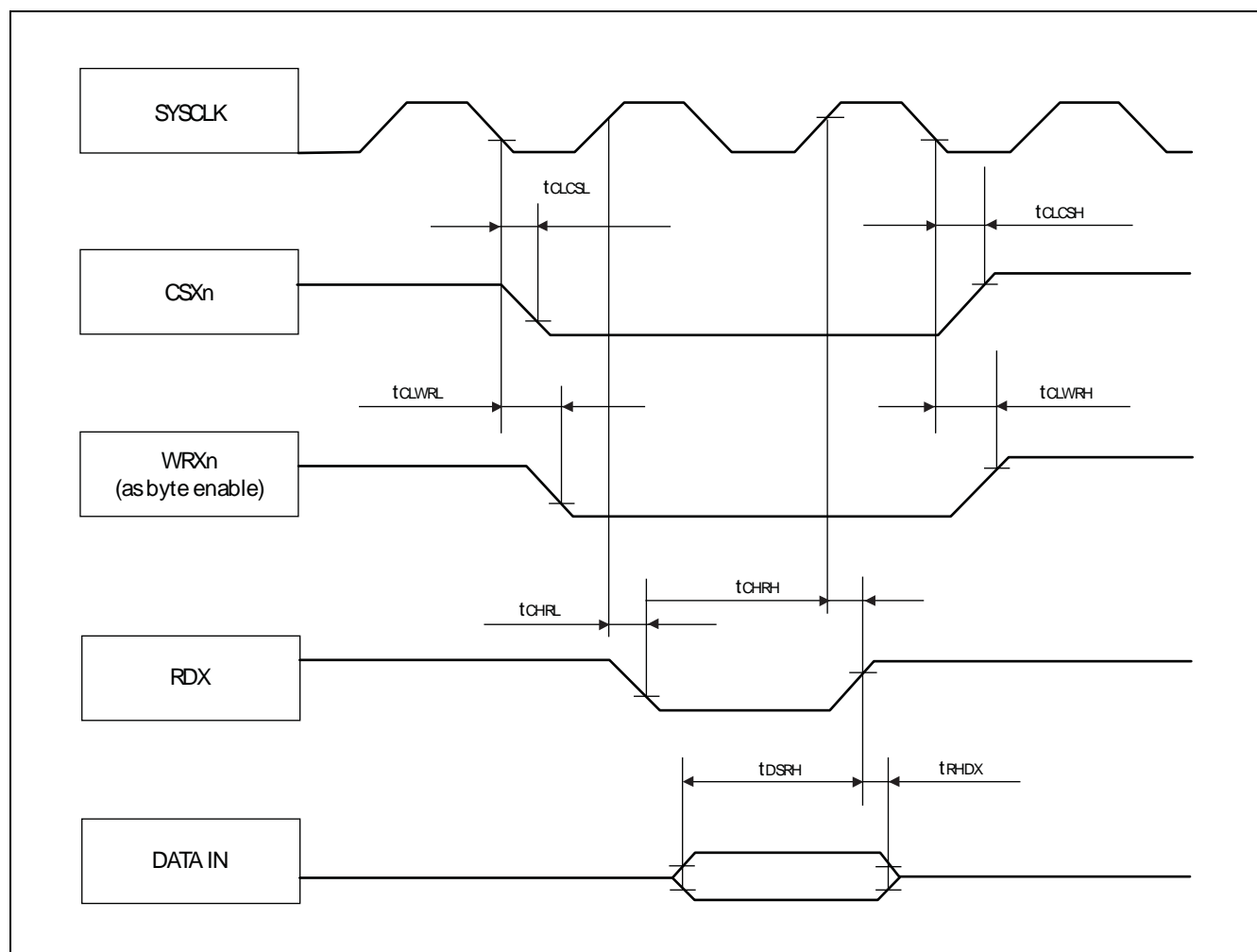

7.8.3. Synchronous write access - byte control type

($V_{DD35} = 3.0\text{ V to }4.5\text{ V}$, $V_{SS5} = AV_{SS5} = 0\text{ V}$, $T_A = -40\text{ }^{\circ}\text{C to }+105\text{ }^{\circ}\text{C}$)

Parameter	Symbol	Pin name	Value		Unit
			Min	Max	
SYSCLK \downarrow to WEX delay time	TCLWL	SYSCLK	—	6	ns
	TCLWH	WEX	3	—	ns
Data valid to WEX \downarrow setup time	TDSWL	WEX D31 to D16	-7	—	ns
WEX \uparrow to Data valid hold time	TWHDH	WEX D31 to D16	$t_{CLKT} - 3$	—	ns
SYSCLK \downarrow to WRXn (as byte enable) delay time	TCLWRL	SYSCLK	—	6	ns
	TCLWRH	WRXn	3	—	ns
SYSCLK \downarrow to CSXn delay time	TCLCSL	SYSCLK	—	11	ns
	TCLCSH	CSXn	—	7	ns

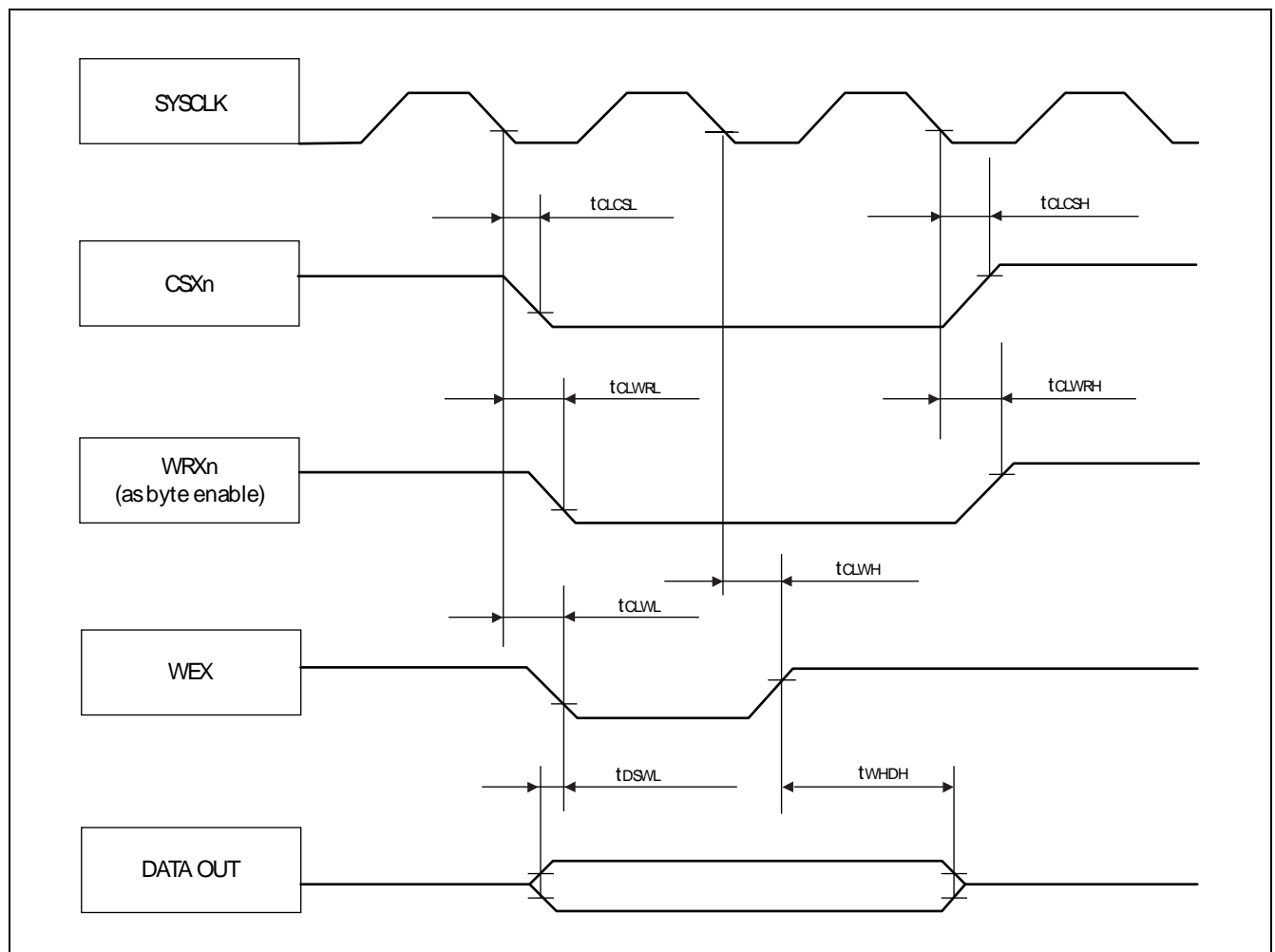

MB91460S Series

7.8.4. Synchronous write access - no byte control type

($V_{DD35} = 3.0\text{ V to }4.5\text{ V}$, $V_{SS5} = AV_{SS5} = 0\text{ V}$, $T_A = -40\text{ }^\circ\text{C to }+105\text{ }^\circ\text{C}$)

Parameter	Symbol	Pin name	Value		Unit
			Min	Max	
SYSCLK \downarrow to WRXn delay time	TCLWRL	SYSCLK WRXn	—	6	ns
	TCLWRH		3	—	ns
Data valid to WRXn \downarrow setup time	TDSWRL	WRXn D31 to D16	-7	—	ns
WRXn \uparrow to Data valid hold time	TWRHDH	WRXn D31 to D16	$t_{CLKT} - 3$	—	ns
SYSCLK \downarrow to CSXn delay time	TCLCSL	SYSCLK CSXn	—	11	ns
	TCLCSH		—	7	ns

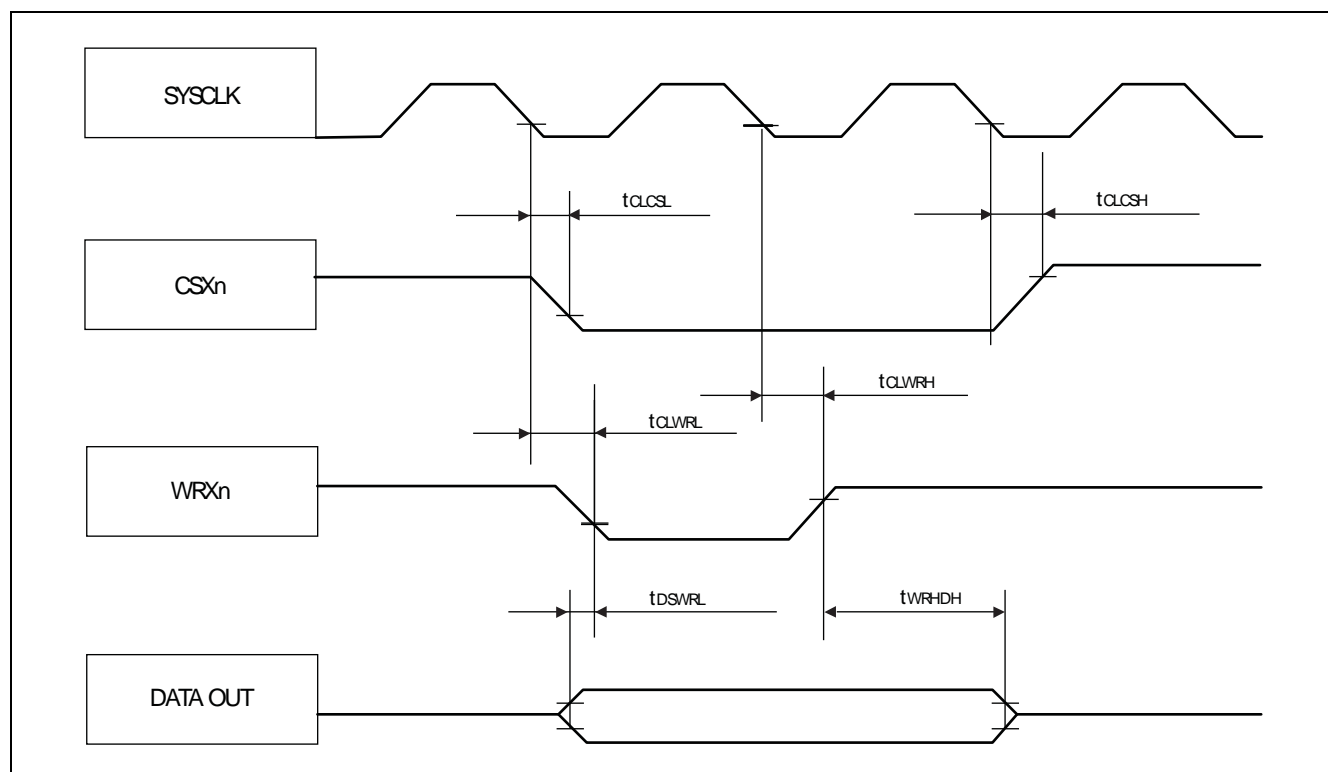

7.8.5. Asynchronous write access - byte control type

($V_{DD35} = 3.0\text{ V to }4.5\text{ V}$, $V_{SS5} = AV_{SS5} = 0\text{ V}$, $T_A = -40\text{ }^\circ\text{C to }+105\text{ }^\circ\text{C}$)

Parameter	Symbol	Pin name	Value		Unit
			Min	Max	
WEX ↓ to WEX ↑ pulse width	TWLWH	WEX	t_{CLKT}	—	ns
Data valid to WEX ↓ setup time	TDSWL	WEX D31 to D16	$1/2 \times t_{CLKT} - 7$	—	ns
WEX ↑ to Data valid hold time	TWHDH	WEX D31 to D16	$1/2 \times t_{CLKT} - 3$	—	ns
WEX to WRXn delay time	TWRLWL	WEX WRXn	—	$1/2 \times t_{CLKT} + 1$	ns
	TWHWRH	WRXn	$1/2 \times t_{CLKT} - 1$	—	ns
WEX to CSXn delay time	TCLWL	WEX CSXn	—	$1/2 \times t_{CLKT} - 1$	ns
	TWHCH	CSXn	$1/2 \times t_{CLKT} - 1$	—	ns

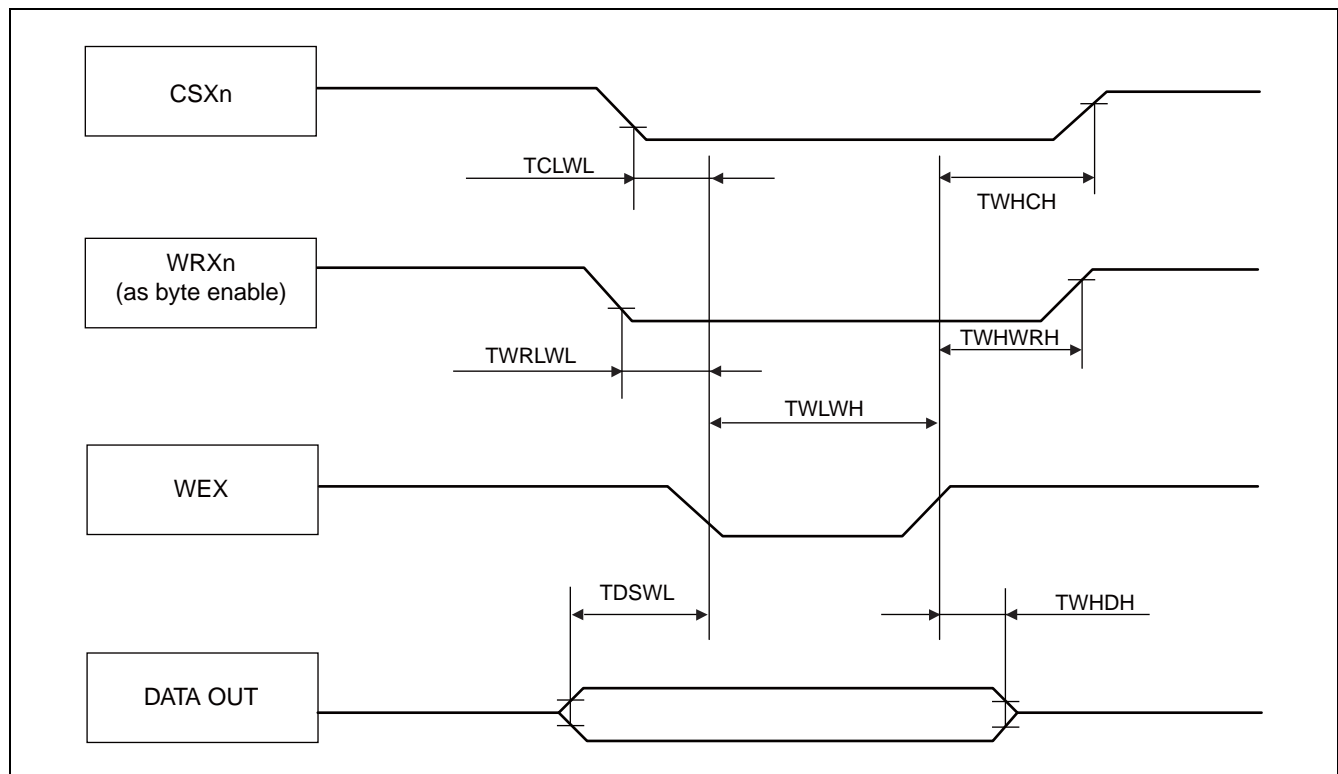

MB91460S Series

7.8.6. Asynchronous write access - no byte control type

($V_{DD35} = 3.0\text{ V to }4.5\text{ V}$, $V_{SS5} = AV_{SS5} = 0\text{ V}$, $T_A = -40\text{ }^{\circ}\text{C to }+105\text{ }^{\circ}\text{C}$)

Parameter	Symbol	Pin name	Value		Unit
			Min	Max	
WRXn ↓ to WRXn ↑ pulse width	TWRLWRH	WRXn	t_{CLKT}	—	ns
Data valid to WRXn ↓ setup time	TDSWRL	WRXn D31 to D16	$1/2 \times t_{CLKT} - 7$	—	ns
WRXn ↑ to Data valid hold time	TWRHDH	WRXn D31 to D16	$1/2 \times t_{CLKT} - 3$	—	ns
WRXn to CSXn delay time	TCLWRL	WRXn	—	$1/2 \times t_{CLKT} + 1$	ns
	TWRHCH	CSXn	$1/2 \times t_{CLKT} - 1$	—	ns

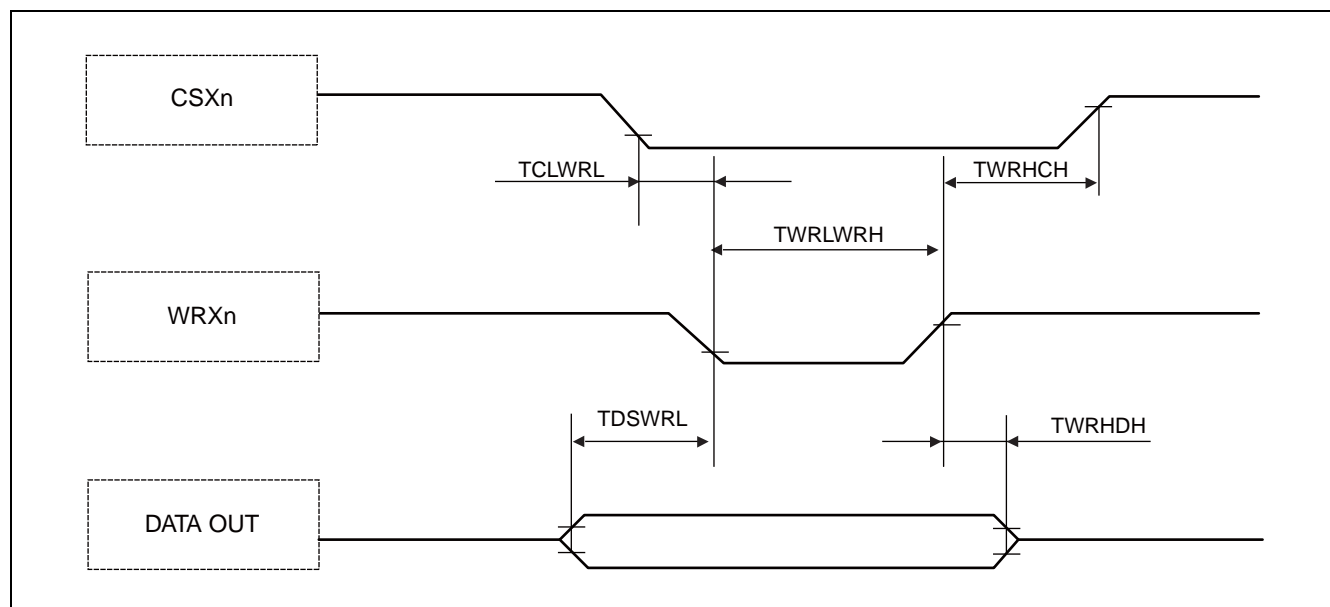

7.8.7. RDY waitcycle insertion

($V_{DD35} = 3.0\text{ V to }4.5\text{ V}$, $V_{SS5} = AV_{SS5} = 0\text{ V}$, $T_A = -40\text{ }^{\circ}\text{C to }+105\text{ }^{\circ}\text{C}$)

Parameter	Symbol	Pin name	Value		Unit
			Min	Max	
RDY setup time	TRDYS	SYSCLK RDY	12	—	ns
RDY hold time	TRDYH	SYSCLK RDY	0	—	ns

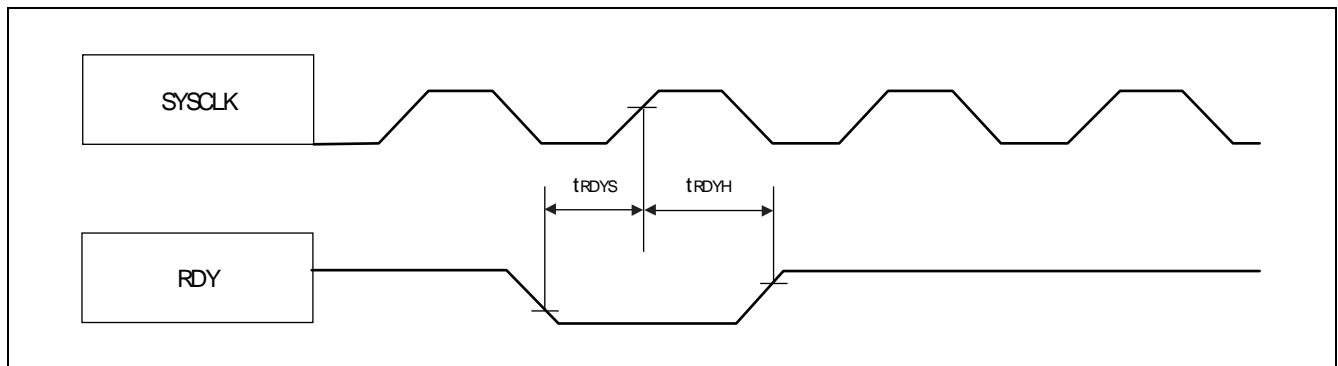

MB91460S Series

■ ORDERING INFORMATION

Part number	Package	Remarks
MB91F467SAPMC-GSE2	176-pin plastic LQFP (FPT-176P-M07)	Lead-free package

PACKAGE DIMENSION

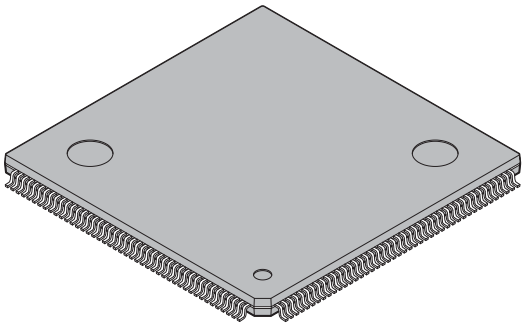
<p>176-pin plastic LQFP</p>  <p>(FPT-176P-M07)</p>	Lead pitch	0.50 mm
	Package width × package length	24.0 × 24.0 mm
	Lead shape	Gullwing
	Sealing method	Plastic mold
	Mounting height	1.70 mm MAX
	Code (Reference)	P-LQFP-0176-2424-0.50

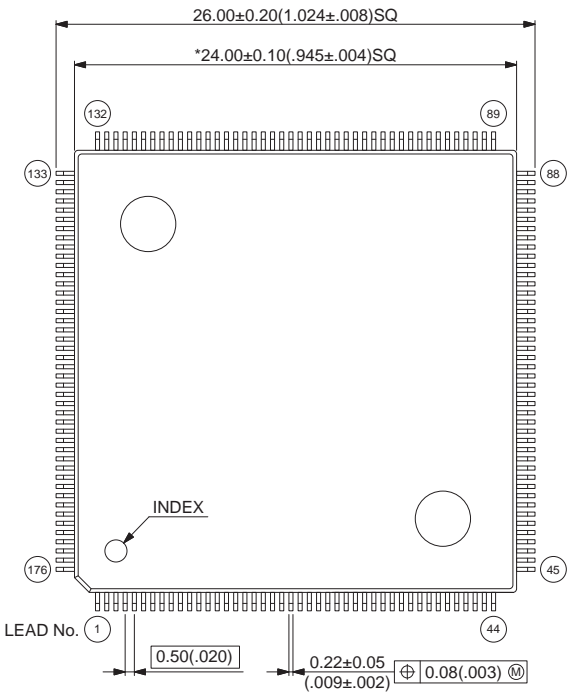
<p>176-pin plastic LQFP (FPT-176P-M07)</p>  <p>©2004-2008 FUJITSU MICROELECTRONICS LIMITED F176013S-c-1-2</p>	<p>Note 1) * : Values do not include resin protrusion. Resin protrusion is +0.25(.010)Max(each side).</p> <p>Note 2) Pins width and pins thickness include plating thickness</p> <p>Note 3) Pins width do not include tie bar cutting remainder.</p> <p>Dimensions in mm (inches). Note: The values in parentheses are reference values.</p>
---	--

Please check the latest package dimension at the following URL.
<http://edevice.fujitsu.com/package/en-search/>

MB91460S Series

Version	Date	Remark
0.10	2007-10-04	Initial draft
0.11	2007-10-10	corrected pindescription
0.12	2007-10-10	added scope
0.13	2007-11-07	updated pinning and featurelist
0.14	2007-11-19	updated the IO-map, Interrupt table and Flash access
0.15	2007-11-26	added APIX® register description, changed scope
0.16	2007-12-04	added trademark information, changed scope
0.17	2008-01-20	updated APIX® register description
0.18	2008-02-12	updated product lineup
0.19	2008-04-10	updated APIX® register description
0.20	2008-04-11	updated APIX® register description, Interruptvectortable
0.21	2008-07-31	added APIX® overview and DMA trigger settings
0.22	2008-08-01	updated APIX® PHY configuration
0.23	2008-08-27	updated APIX® controller description
0.24	2008-09-03	updated electrical characteristics and APIX® controller description
0.25	2009-02-02	updated APIX® RH description, operating conditions and AC characteristics, added clockmodulator limitation
0.26	2009-02-04	updated APIX® RH description and operating conditions
0.27	2009-02-10	added trademark information
0.28	2009-03-03	updated product lineup and electrical characteristics
0.29	2009-03-10	updated ADC electrical characteristics
0.30	2009-05-08	corrected default values for PFR00 to PFR10 and level for AC specification
1.00	2009-06-02	corrected AC specification
1.01	2009-06-05	updated DC characteristics
1.02	2009-06-17	updated ordering information

■ MAIN CHANGES IN THIS EDITION

Page	Section	Change Results
—	—	Preliminary Data Sheet → Data Sheet

The vertical lines marked in the left side of the page show the changes.

MB91460S Series

FUJITSU MICROELECTRONICS LIMITED

Shinjuku Dai-Ichi Seimei Bldg., 7-1, Nishishinjuku 2-chome,
Shinjuku-ku, Tokyo 163-0722, Japan
Tel: +81-3-5322-3329
<http://jp.fujitsu.com/fml/en/>

For further information please contact:

North and South America

FUJITSU MICROELECTRONICS AMERICA, INC.
1250 E. Arques Avenue, M/S 333
Sunnyvale, CA 94085-5401, U.S.A.
Tel: +1-408-737-5600 Fax: +1-408-737-5999
<http://www.fma.fujitsu.com/>

Asia Pacific

FUJITSU MICROELECTRONICS ASIA PTE. LTD.
151 Lorong Chuan,
#05-08 New Tech Park 556741 Singapore
Tel : +65-6281-0770 Fax : +65-6281-0220
<http://www.fmal.fujitsu.com/>

Europe

FUJITSU MICROELECTRONICS EUROPE GmbH
Pittlerstrasse 47, 63225 Langen, Germany
Tel: +49-6103-690-0 Fax: +49-6103-690-122
<http://emea.fujitsu.com/microelectronics/>

FUJITSU MICROELECTRONICS SHANGHAI CO., LTD.

Rm. 3102, Bund Center, No.222 Yan An Road (E),
Shanghai 200002, China
Tel : +86-21-6146-3688 Fax : +86-21-6335-1605
<http://cn.fujitsu.com/fmc/>

Korea

FUJITSU MICROELECTRONICS KOREA LTD.
206 Kosmo Tower Building, 1002 Daechi-Dong,
Gangnam-Gu, Seoul 135-280, Republic of Korea
Tel: +82-2-3484-7100 Fax: +82-2-3484-7111
<http://kr.fujitsu.com/fmk/>

FUJITSU MICROELECTRONICS PACIFIC ASIA LTD.

10/F., World Commerce Centre, 11 Canton Road,
Tsimshatsui, Kowloon, Hong Kong
Tel : +852-2377-0226 Fax : +852-2376-3269
<http://cn.fujitsu.com/fmc/en/>

Specifications are subject to change without notice. For further information please contact each office.

All Rights Reserved.

The contents of this document are subject to change without notice.

Customers are advised to consult with sales representatives before ordering.

The information, such as descriptions of function and application circuit examples, in this document are presented solely for the purpose of reference to show examples of operations and uses of FUJITSU MICROELECTRONICS device; FUJITSU MICROELECTRONICS does not warrant proper operation of the device with respect to use based on such information. When you develop equipment incorporating the device based on such information, you must assume any responsibility arising out of such use of the information.

FUJITSU MICROELECTRONICS assumes no liability for any damages whatsoever arising out of the use of the information.

Any information in this document, including descriptions of function and schematic diagrams, shall not be construed as license of the use or exercise of any intellectual property right, such as patent right or copyright, or any other right of FUJITSU MICROELECTRONICS or any third party or does FUJITSU MICROELECTRONICS warrant non-infringement of any third-party's intellectual property right or other right by using such information. FUJITSU MICROELECTRONICS assumes no liability for any infringement of the intellectual property rights or other rights of third parties which would result from the use of information contained herein.

The products described in this document are designed, developed and manufactured as contemplated for general use, including without limitation, ordinary industrial use, general office use, personal use, and household use, but are not designed, developed and manufactured as contemplated (1) for use accompanying fatal risks or dangers that, unless extremely high safety is secured, could have a serious effect to the public, and could lead directly to death, personal injury, severe physical damage or other loss (i.e., nuclear reaction control in nuclear facility, aircraft flight control, air traffic control, mass transport control, medical life support system, missile launch control in weapon system), or (2) for use requiring extremely high reliability (i.e., submersible repeater and artificial satellite).

Please note that FUJITSU MICROELECTRONICS will not be liable against you and/or any third party for any claims or damages arising in connection with above-mentioned uses of the products.

Any semiconductor devices have an inherent chance of failure. You must protect against injury, damage or loss from such failures by incorporating safety design measures into your facility and equipment such as redundancy, fire protection, and prevention of over-current levels and other abnormal operating conditions.

Exportation/release of any products described in this document may require necessary procedures in accordance with the regulations of the Foreign Exchange and Foreign Trade Control Law of Japan and/or US export control laws.

The company names and brand names herein are the trademarks or registered trademarks of their respective owners.