

PGA400-Q1 Pressure-Sensor Signal Conditioner

1 Features

- Analog Features
 - Analog Front-End for Resistive Bridge Sensors
 - Self-Oscillating Demodulator for Capacitive Sensors
 - On-Chip Temperature Sensor
 - Programmable Gain
 - 16-Bit, 1-MHz Sigma-Delta Analog-to-Digital Converter for Signal Channel
 - 10-Bit Sigma-Delta Analog-to-Digital Converter for Temperature Channel
 - Two 12-Bit Digital-to-Analog Outputs
- Digital Features
 - Microcontroller Core
 - 10-MHz 8051 WARP Core
 - 2 Clocks Per Instruction Cycle
 - On-Chip Oscillator
 - Memory
 - 8KB of OTP Memory
 - 89 Bytes of EEPROM
 - 256 Bytes Data SRAM
- Peripheral Features
 - Serial Peripheral Interface (SPI)
 - Inter-Integrated Circuit (I²C)
 - One-Wire Interface (OWI)
 - Two Input Capture Ports
 - Two Output Compare Ports
 - Software Watchdog Timer
 - Oscillator Watchdog
 - Power Management Control
 - Analog Low-Voltage Detect
- General Features
 - AEC-Q100 Qualified With the Following Results:
 - Device Temperature Grade 1: –40°C to +125°C Ambient Operating Temperature
 - Device HBM ESD Classification Level 2
 - Device HBM ESD Classification Level C3B
 - Power Supply: 4.5-V to 5.5-V Operational, –5.5-V to 16-V Absolute Maximum

2 Applications

- Pressure Sensor-Signal Conditioning
- Level Sensor-Signal Conditioning
- Humidity Sensor-Signal Conditioning

3 Description

The PGA400-Q1 device is an interface device for piezoresistive, strain gauge, and capacitive-sense elements. The device incorporates the analog front end (AFE) that directly connects to the sense element and has voltage regulators and an oscillator. The device also includes a sigma-delta analog-to-digital converter (ADC), 8051 WARP core microprocessor, and OTP memory. Sensor compensation algorithms can be implemented in software. The PGA400-Q1 device also includes two digital-to-analog converter (DAC) outputs.

Table 1. Device Information⁽¹⁾

PART NUMBER	PACKAGE	BODY SIZE (NOM)
PGA400QRHHRQ1	VQFN (36)	6.00 mm x 6.00 mm
PGA400QYZRQ1	WCSP (36)	3.65 mm x 3.65 mm

(1) For all available packages, see the orderable addendum at the end of the data sheet.

Figure 1. Simplified Schematic

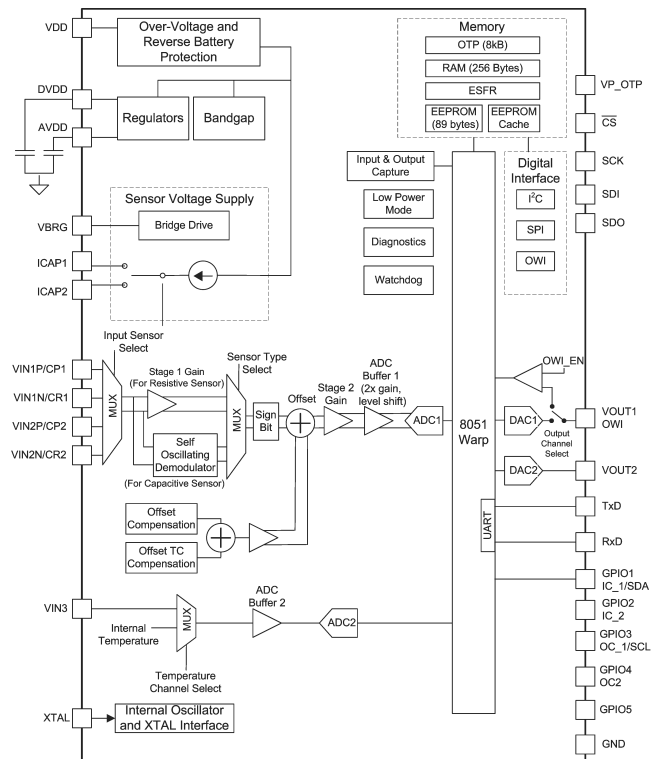

Table of Contents

1 Features	1	6.20 Input Capture and Output Compare Port Characteristics	12
2 Applications	1	6.21 Diagnostic Characteristics	13
3 Description	1	6.22 SPI Timing Requirements	13
4 Revision History	2	6.23 I ² C Interface Timing Requirements	14
5 Pin Configuration and Functions	3	6.24 Typical Characteristics	15
6 Specifications	6	7 Detailed Description	19
6.1 Absolute Maximum Ratings	6	7.1 Functional Block Diagram	19
6.2 ESD Ratings	6	7.2 Feature Description	19
6.3 Recommended Operating Conditions	6	7.3 Programming and Memory	50
6.4 Thermal Information	7	7.4 General Purpose Input Output (GPIO) Pins	57
6.5 Overvoltage Protection Characteristics	7	7.5 8051W UART	58
6.6 Regulator Characteristics	7	7.6 DAC Output	58
6.7 Internal Oscillator and External Crystal Interface Characteristics	7	7.7 Input Capture and Output Compare	58
6.8 Sensor Supply Characteristics	8	7.8 Diagnostics	59
6.9 Temperature Sensor Characteristics	8	7.9 Low-Power Mode	63
6.10 Stage 1 Gain Characteristics of the Analog Front End for Resistive Bridge Sensors	9	7.10 Register Maps	63
6.11 Stage 2 Gain Characteristics	9	8 Application and Implementation	109
6.12 Offset and Offset TC Compensation Characteristics	10	8.1 Typical Application	109
6.13 ADC Characteristics	10	9 Device and Documentation Support	110
6.14 OWI Characteristics	11	9.1 Documentation Support	110
6.15 SPI Characteristics	11	9.2 Receiving Notification of Documentation Updates	110
6.16 I ² C Interface Characteristics	11	9.3 Community Resources	110
6.17 Non-Volatile Memory Characteristics	11	9.4 Trademarks	110
6.18 GPIO Characteristics	12	9.5 Electrostatic Discharge Caution	110
6.19 DAC1 and DAC2 Output Characteristics	12	9.6 Glossary	110
		10 Mechanical, Packaging, and Orderable Information	110

4 Revision History

Changes from Original (March 2012) to Revision A	Page
• Added <i>Pin Configuration and Functions</i> section, <i>ESD Ratings</i> table, <i>Feature Description</i> section, <i>Application and Implementation</i> section, <i>Device and Documentation Support</i> section, and <i>Mechanical, Packaging, and Orderable Information</i> section	1
• Added RHH package	1
• Added <i>Typical Characteristics</i> section	15
• Added information for RHH package to <i>Detailed Description</i> section	19
• Added <i>Register Maps</i> section	63

5 Pin Configuration and Functions

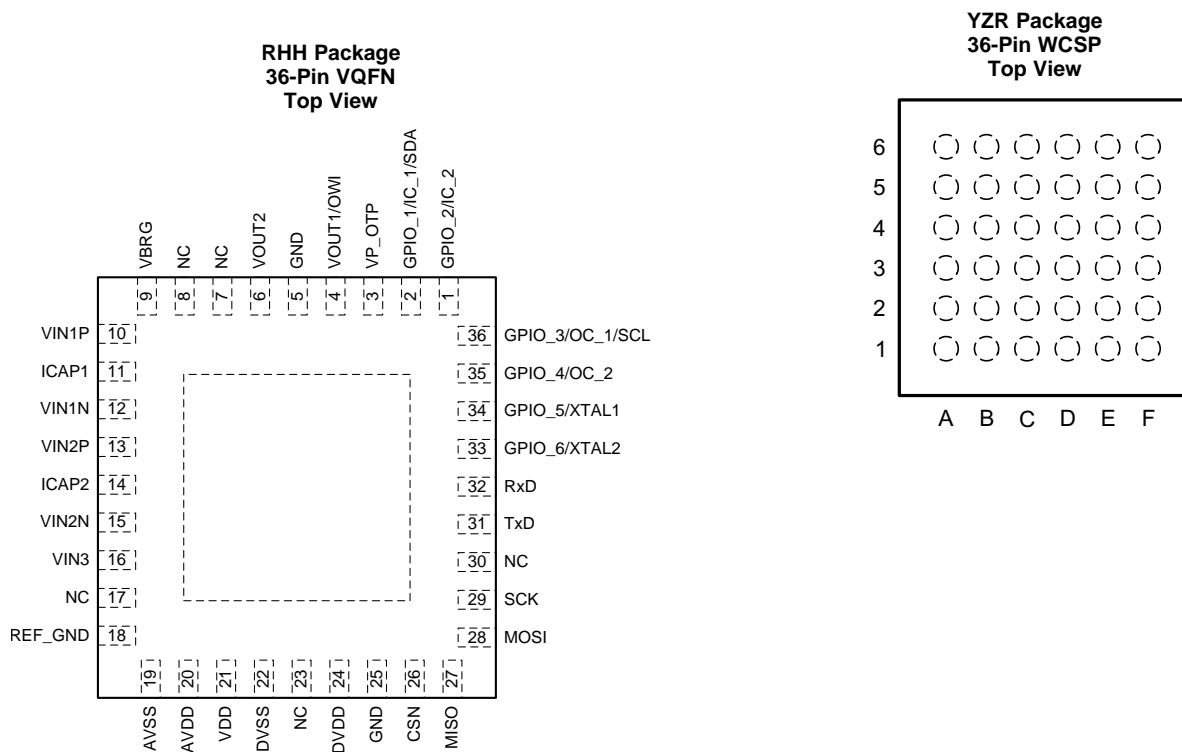

Pin Functions - RHH Package

NO.	PIN		TYPE	DESCRIPTION
		NAME		
1	GPIO_2/IC_2	I/O	General purpose IO 2 / input capture port 2	
2	GPIO_1/IC_1/SDA	I/O	General purpose IO 1 / input capture port 1 / I ² C data	
3	VP_OTP	PWR	OTP programming voltage	
4	VOUT1/OWI	I/O	DAC1 output / OWI	
5	GND	PWR	Ground	
6	VOUT2	O	DAC2 output	
7	NC	NC	No connect ⁽¹⁾	
8	NC	NC	No connect ⁽¹⁾	
9	VBRG	PWR	Resistive bridge supply voltage	
10	VIN1P/CP1	I	Resistive sensor 1 positive input / capacitive sensor 1 positive input	
11	ICAP1	PWR	Capacitive sensor drive current 1	
12	VIN1N/CR1	I	Resistive sensor 1 negative input / capacitive sensor 1 reference input	
13	VIN2P/CP2	I	Resistive sensor 2 positive input / capacitive sensor 2 positive input	
14	ICAP2	PWR	Capacitive sensor drive current 2	
15	VIN2N/CR2	I	Resistive sensor 2 negative input / capacitive sensor 2 reference input	
16	VIN3	I	External temp sensor input	
17	NC	NC	No connect ⁽¹⁾	
18	REF_GND	PWR	Quiet ground reference	
19	AVSS	PWR	Analog ground	
20	AVDD	PWR	Linear regulator output for internal analog circuit supply	
21	VDD	PWR	Input power supply	
22	DVSS	PWR	Digital ground	

(1) Recommended to be connected to GND.

Pin Functions - RHH Package (continued)

PIN		TYPE	DESCRIPTION
NO.	NAME		
23	NC	NC	No connect ⁽¹⁾
24	DVDD	PWR	Linear regulator output for Internal digital circuit supply
25	GND	PWR	Ground
26	CSN	I	SPI chip select
27	MISO	O	SPI slave data out
28	MOSI	I	SPI slave data in
29	SCK	I	SPI clock
30	NC	NC	No connect ⁽¹⁾
31	TxD	O	8051 UART Tx (port 3_1)
32	RxD	I	8051 UART Rx (port 3_0)
33	XTAL	I/O	External crystal2
34	GPIO_5	I/O	General purpose IO 5
35	GPIO_4/OC_2	I/O	General purpose IO 4 / output capture port 2
36	GPIO_3/OC_1/SCL	I/O	General purpose IO 3 / output capture port 1 / I ² C clock

Pin Functions - YZR Package

PIN		TYPE	DESCRIPTION
NO.	NAME		
A1	VIN1P / CP1	I/O	Resistive sensor 1 positive input / capacitive sensor 1 positive input
A2	ICAP1	I/O	Capacitive sensor drive current 1
A3	VIN1N / CR1	PWR	Resistive sensor 1 negative input / capacitive sensor 1 reference input
A4	VIN2P / CP2	I/O	Resistive sensor 2 positive input / capacitive sensor 2 positive input
A5	ICAP2	PWR	Capacitive sensor drive current 2
A6	VIN2N / CR2	O	Resistive sensor 2 negative input / capacitive sensor 2 reference input
B1	VBRG	NC	Resistive bridge supply voltage
B2	GND	NC	Ground
B3	GND	PWR	Ground
B4	VIN3	I	External temperature sensor input
B5	GND	PWR	Ground
B6	GND	I	Ground
C1	VOUT2	I	DAC2 output
C2	GPIO_1 / IC_1 / SDA	PWR	General purpose IO 1 / input capture port 1 / I ² C data
C3	GND	I	Ground
C4	GND	I	Ground
C5	GND	NC	Ground
C6	AVDD	PWR	Linear regulator output for internal analog circuit supply
D1	VOUT1 / OWI	PWR	DAC1 output / one-wire interface
D2	GPIO_2 / IC_2	PWR	General purpose IO 2 / input capture port 2
D3	GPIO_4 / OC_2	PWR	General purpose IO 4 / output compare port 2
D4	RXD	PWR	8051 UART Rx (Port 3_0)
D5	GND	NC	Ground
D6	VDD	PWR	Input power supply
E1	VP_OTP	PWR	One-time programmable memory programming voltage
E2	XTAL	I	External crystal input
E3	GPIO_3 / OC_1 / SCL	O	General purpose IO 3 / output compare port 1 / I ² C clock
E4	TXD	I	8051 UART Tx (Port 3_1)

Pin Functions - YZR Package (continued)

PIN		TYPE	DESCRIPTION
NO.	NAME		
E5	GND	I	Ground
E6	GND	NC	Ground
F1	GPIO_5	O	General purpose IO 5
F2	SCK	I	Serial peripheral interface clock
F3	SDI	I/O	Serial peripheral interface slave data in
F4	SDO	I/O	Serial peripheral interface slave data out
F5	$\overline{\text{CS}}$	I/O	Serial peripheral interface chip select
F6	DVDD	I/O	Linear regulator output for internal digital circuit supply

6 Specifications

6.1 Absolute Maximum Ratings

over operating free-air temperature range (unless otherwise noted)⁽¹⁾

		MIN	MAX	UNIT
V _{DD}	Power supply voltage, continuous	-5.5	16	V
	Voltage at VP_OTP	-0.3	8	V
	Voltage at sensor input and drive pins	-0.3	3.6	V
	Voltage at any IO pin except at VOUT1/OWI	-0.3	V _{DD} + 0.3	V
	Voltage at VOUT1/OWI pin	-0.3	7.5	V
	Supply current	I _{DD} , short on VOUT1 or VOUT2		mA
	Output current	VOUT1, VOUT2		mA
T _{Jmax}	Maximum junction temperature		150	°C
T _{lead}	Lead temperature (soldering, 10 s)		260	°C
T _{stg}	Storage temperature	-40	150	°C

(1) Stresses beyond those listed under *Absolute Maximum Ratings* may cause permanent damage to the device. These are stress ratings only and functional operation of the device at these or any other conditions beyond those indicated under *Recommended Operating Conditions* are not implied. Exposure to absolute-maximum-rated conditions for extended periods may affect device reliability.

6.2 ESD Ratings

		VALUE	UNIT
V _(ESD)	Electrostatic discharge	Human body model (HBM), per AEC Q100-002 ⁽¹⁾	±2000
		Charged device model (CDM), per AEC Q100-011	±500

(1) AEC Q100-002 indicates HBM stressing is done in accordance with the ANSI/ESDA/JEDEC JS-001 specification.

6.3 Recommended Operating Conditions

over operating free-air temperature range (unless otherwise noted)

		MIN	NOM	MAX	UNIT
V _{DD}	Power supply voltage	4.5	5	5.5	V
I _{DD}	Power supply current	Normal mode ⁽¹⁾		13.6	mA
		Low-power mode ⁽²⁾		9.5	
VP_OTP	OTP programming voltage	7	7.4	7.8	V
I _{VP_OTP}	OTP programming current	During OTP programming		3	mA
t _{prog_OTP}	OTP programming timing per byte	120			µs
T _A	Operating ambient temperature	-40		125	°C
	Programming temperature	OTP or EEPROM		140	°C
	Start-up time ⁽³⁾	V _{DD} ramp rate 1 V/µs		250	µs

(1) V_{DD} = 5 V, no load on VBRG, no load on DAC1 and DAC2.

(2) V_{DD} = 5.5 V, no load on VBRG, no load on DAC1 and DAC2, AFE turned OFF.

(3) Start-up time is measured from when voltage supply is applied to when the MCU starts operating.

6.4 Thermal Information

THERMAL METRIC ⁽¹⁾		PGA400-Q1		UNIT
		RHH (VQFN)	YZR (WCSP)	
		36 PINS	36 PINS	
R _{θJA}	Junction-to-ambient thermal resistance	30.6	53	°C/W
R _{θJC(top)}	Junction-to-case (top) thermal resistance	16.4	0.3	°C/W
R _{θJB}	Junction-to-board thermal resistance	5.4	2.5	°C/W
ψ _{JT}	Junction-to-top characterization parameter	0.2	1.4	°C/W
ψ _{JB}	Junction-to-board characterization parameter	5.4	2.2	°C/W
R _{θJC(bot)}	Junction-to-case (bottom) thermal resistance	0.7	—	°C/W

(1) For more information about traditional and new thermal metrics, see the *Semiconductor and IC Package Thermal Metrics* application report, [SPRA953](#).

6.5 Overvoltage Protection Characteristics

PARAMETER	TEST CONDITIONS	MIN	TYP	MAX	UNIT
OV	Overvoltage protection threshold	5.5	6.1	7	V
OV _{hyst}	Overvoltage protection hysteresis		410		mV

6.6 Regulator Characteristics

over operating free-air temperature range (unless otherwise noted)

PARAMETER	TEST CONDITIONS	MIN	TYP	MAX	UNIT
V _{AVDD}	AVDD voltage		3.3		V
I _{AVDD}	AVDD current			5	mA
V _{DVDD}	DVDD voltage	No EEPROM programming, capacitance = 100 nF		3.3	V
		EEPROM programming, capacitance = 100 nF		3.6	V

6.7 Internal Oscillator and External Crystal Interface Characteristics

over operating free-air temperature range (unless otherwise noted)

PARAMETER	TEST CONDITIONS	MIN	TYP	MAX	UNIT
INTERNAL OSCILLATOR					
Internal oscillator frequency	T _A = 25°C	38.4	40	41.6	MHz
Internal oscillator frequency	Across operating temperature	36.3		43.7	MHz
EXTERNAL 40-MHZ CRYSTAL⁽¹⁾					
Low-level input voltage on XTAL		-0.3	0.1 × V _{DD}		V
High-level input voltage on XTAL		0.7 × V _{DD}	V _{DD} + 0.3		V

(1) Clock source change occurs 50 ms after the XTAL_EN has been toggled.

6.8 Sensor Supply Characteristics

over operating free-air temperature range (unless otherwise noted)

PARAMETER		TEST CONDITIONS	MIN	TYP	MAX	UNIT
VBRG SUPPLY FOR RESISTIVE BRIDGE SENSORS						
V _{BRG}	Supply voltage	0.44 kΩ ≤ R _{BRG} ≤ 20 kΩ	3.2	3.33	3.4	V
R _{BRG}	Resistive bridge resistance		0.44		20	kΩ
C _{BRG}	Capacitive load	R _{BRG} = 20 kΩ			500	pF
	Line regulation	V _{DD} = 4.5 V, 5.5 V, R _{BRG} = 0.44 kΩ	−40		40	mV
	Load regulation	V _{DD} = 5 V, 10 μA ≤ I _{LOAD} ≤ 10 mA	−40		40	mV
ICAPx SUPPLY FOR CAPACITIVE SENSORS						
ICAP_A	Supply current amplitude on ICAP, T _A = 25°C	CI[2:0] = 000, ICAP_V = 100 mV	−5.3		−4.3	μA
		CI[2:0] = 001, ICAP_V = 100 mV	−8		−6.6	
		CI[2:0] = 010, ICAP_V = 100 mV	−10.8		−8.8	
		CI[2:0] = 011, ICAP_V = 100 mV	−13.5		−11.1	
		CI[2:0] = 100, ICAP_V = 100 mV	−16.2		−13.3	
		CI[2:0] = 101, ICAP_V = 100 mV	−18.9		−15.5	
		CI[2:0] = 110, ICAP_V = 100 mV	−21.6		−17.8	
		CI[2:0] = 111, ICAP_V = 100 mV	−24.4		−20.1	
		CI[2:0] = 000, ICAP_V = 3.2 V	4.5		5.6	
		CI[2:0] = 001, ICAP_V = 3.2 V	6.9		8.5	
		CI[2:0] = 010, ICAP_V = 3.2 V	9.2		11.3	
		CI[2:0] = 011, ICAP_V = 3.2 V	11.5		14.1	
		CI[2:0] = 100, ICAP_V = 3.2 V	13.6		16.7	
		CI[2:0] = 101, ICAP_V = 3.2 V	15.8		19.2	
		CI[2:0] = 110, ICAP_V = 3.2 V	18.1		22.1	
		CI[2:0] = 111, ICAP_V = 3.2 V	20.4		24.8	
	Variation over temperature		−5%		5%	
CPx_V, CRx_V	Capacitive sensor drive; voltage at CPx and CRx pins	CV[1:0] = 00	70	90	110	mV
		CV[1:0] = 01	255	300	345	
		CV[1:0] = 10	425	500	575	
		CV[1:0] = 11	595	700	805	
SELF OSCILLATING CURRENT MODE DEMODULATOR FOR CAPACITIVE SENSORS						
R _F / R _{REF}	Gain in transimpedance amplifier	CR[1:0] = 00, R _{REF} = 78 kΩ	−1.07	−1.01	−0.94	V/V
		CR[1:0] = 01, R _{REF} = 78 kΩ	−2.13	−1.97	−1.82	
		CR[1:0] = 10, R _{REF} = 78 kΩ	−4.24	−3.93	−3.63	
		CR[1:0] = 11, R _{REF} = 78 kΩ	−8.45	−7.85	−7.26	
C _f	Feedback capacitor in transimpedance amplifier		14	16	18	pF

6.9 Temperature Sensor Characteristics

over operating free-air temperature range (unless otherwise noted)

PARAMETER	TEST CONDITIONS	MIN	TYP	MAX	UNIT
Temperature range		−40		150	°C
Temperature ADC resolution			10		bits
Temperature ADC update rate			8		ms
Gain ⁽¹⁾		2.7	2.8	2.9	LSB/°C
Offset ⁽¹⁾		−105		−66	LSB
Total error ⁽²⁾		−4		4	°C

(1) The temperature ADC value is given by the equation: ADC Code = Gain × Temperature (in °C) + Offset.

(2) ±4°C possible only if customer uses the temperature ADC values stored in EEPROM before the parts ship from TI.

6.10 Stage 1 Gain Characteristics of the Analog Front End for Resistive Bridge Sensors

over operating free-air temperature range (unless otherwise noted)

PARAMETER	TEST CONDITIONS	MIN	TYP	MAX	UNIT
Gain steps	Sx_G1[2:0] = 000		3		V/V
	Sx_G1[2:0] = 001		4.4		
	Sx_G1[2:0] = 010		6.8		
	Sx_G1[2:0] = 011		10.2		
	Sx_G1[2:0] = 100		14.6		
	Sx_G1[2:0] = 101		25.5		
	Sx_G1[2:0] = 110		34		
	Sx_G1[2:0] = 111		51		
Bandwidth	-3 dB, Gain = 111		7		KHz

6.11 Stage 2 Gain Characteristics

over operating free-air temperature range (unless otherwise noted)

PARAMETER	TEST CONDITIONS	MIN	TYP	MAX	UNIT
Gain steps	Sx_G2[4:0] = 00000	0.97	1.01	1.05	V/V
	Sx_G2[4:0] = 00001	1.06	1.11	1.16	
	Sx_G2[4:0] = 00010	1.18	1.23	1.28	
	Sx_G2[4:0] = 00011	1.31	1.37	1.42	
	Sx_G2[4:0] = 00100	1.45	1.52	1.58	
	Sx_G2[4:0] = 00101	1.61	1.68	1.76	
	Sx_G2[4:0] = 00110	1.79	1.87	1.94	
	Sx_G2[4:0] = 00111	1.98	2.07	2.16	
	Sx_G2[4:0] = 01000	2.2	2.29	2.39	
	Sx_G2[4:0] = 01001	2.44	2.55	2.65	
	Sx_G2[4:0] = 01010	2.71	2.83	2.94	
	Sx_G2[4:0] = 01011	3	3.13	3.26	
	Sx_G2[4:0] = 01100	3.34	3.48	3.62	
	Sx_G2[4:0] = 01101	3.74	3.9	4.06	
	Sx_G2[4:0] = 01110	4.12	4.3	4.48	
	Sx_G2[4:0] = 01111	4.61	4.81	5.01	
	Sx_G2[4:0] = 10000	5.09	5.31	5.54	
	Sx_G2[4:0] = 10001	5.67	5.92	6.16	
	Sx_G2[4:0] = 10010	6.26	6.52	6.79	
	Sx_G2[4:0] = 10011	6.93	7.23	7.53	
	Sx_G2[4:0] = 10100	7.7	8.04	8.37	
	Sx_G2[4:0] = 10101	8.57	8.95	9.32	
	Sx_G2[4:0] = 10110	9.54	9.96	10.37	
	Sx_G2[4:0] = 10111	10.62	11.06	11.51	
	Sx_G2[4:0] = 11000	11.76	12.27	12.79	
	Sx_G2[4:0] = 11001	13.02	13.58	14.15	
	Sx_G2[4:0] = 11010	14.48	15.1	15.72	
	Sx_G2[4:0] = 11011	16.03	16.71	17.4	
	Sx_G2[4:0] = 11100	17.72	18.53	19.34	
	Sx_G2[4:0] = 11101	19.61	20.49	21.37	
	Sx_G2[4:0] = 11110	21.72	22.7	23.68	
	Sx_G2[4:0] = 11111	23.85	25.06	26.28	
Bandwidth	-3 dB, Gain Setting = 11111	120			kHz

6.12 Offset and Offset TC Compensation Characteristics

over operating free-air temperature range (unless otherwise noted)

PARAMETER	TEST CONDITIONS	MIN	TYP	MAX	UNIT
Offset compensation low	Offset setting = 0x000, Stage 1 gain setting = 0b000	-385	-324	-279	mV
Offset compensation high	Offset setting = 0x3FF, Stage 1 gain setting = 0b000	279	324	385	mV
Offset compensation resolution	Stage 1 gain setting = 0b000	0.59		0.72	mV/step
Offset TC compensation low	Offset TC setting = 0x00, Stage 1 gain value = 0b000		-371		$\mu\text{V}/^\circ\text{C}$
Offset TC compensation high	Offset TC setting = 0x3F, Stage 1 gain value = 0b000		361		$\mu\text{V}/^\circ\text{C}$
Offset TC compensation resolution	Stage 1 gain value = 0b000		11.6		$\mu\text{V}/^\circ\text{C}/\text{step}$
Reference temperature			22		$^\circ\text{C}$

6.13 ADC Characteristics

over operating free-air temperature range (unless otherwise noted)

PARAMETER	TEST CONDITIONS	MIN	TYP	MAX	UNIT
ADC BUFFER FOR 16-BIT AD CONVERTER 1					
Gain		1.9	2	2.1	V/V
DC level shift	ADC_BUF bit = 1	-1.74	-1.65	-1.55	V
DC offset		-15		15	mV
ADC BUFFER FOR 10-BIT AD CONVERTER 2					
VIN3 input voltage range		0.425		1.7	V
Gain		1.09	1.15	1.21	V/V
DC offset		-15		15	mV
VIN3 VOLTAGE VERSUS ADC CODE					
Gain ⁽¹⁾		740	760	780	LSB/V
Offset ⁽¹⁾		-850	-820	-790	LSB
Gain temperature coefficient	T _A = 25 $^\circ\text{C}$		0.02		LSB/V/ $^\circ\text{C}$
Offset temperature coefficient	T _A = 25 $^\circ\text{C}$		-0.02		LSB/ $^\circ\text{C}$
Integral nonlinearity		-1		1	LSB

(1) ADC Code = Gain × VIN3 + Offset.

6.14 OWI Characteristics

over operating free-air temperature range (unless otherwise noted)

PARAMETER		TEST CONDITIONS	MIN	TYP	MAX	UNIT
Communication baud rate			2400		115000	bits per second
OWI_EN	OWI enable		6.5		7	V
OWI_EN _{hys}	OWI enable hysteresis			50		mV
Internal pullup				10		kΩ
Activation signal pulse low time			12			ms
Activation signal pulse high time			12			ms
OWI_VIH	OWI transceiver Rx threshold		$0.7 \times V_{DD}$		$V_{DD} + 0.3$	V
OWI_VIL	OWI transceiver Rx threshold		-0.3		$0.3 \times V_{DD}$	V
OWI_VOH	OWI transceiver Tx threshold	$V_{DD} = 5\text{ V}$	4			
OWI_VOL	OWI transceiver Tx threshold	$V_{DD} = 5\text{ V}$			0.8	V

6.15 SPI Characteristics

over operating free-air temperature range (unless otherwise noted)

PARAMETER		TEST CONDITIONS	MIN	TYP	MAX	UNIT
f_{SCK}	SPI frequency				4	MHz
V_{IH}	High-level input voltage		$0.7 \times V_{DD}$		$V_{DD} + 0.3$	V
V_{IL}	Low-level input voltage		-0.3		$0.3 \times V_{DD}$	V
V_{OH}	High-level output voltage		4			V
V_{OL}	Low-level output voltage				0.8	V
$C_{L(SDO)}$	Capacitive load for data output (SDO)			10		pF

6.16 I²C Interface Characteristics

over operating free-air temperature range (unless otherwise noted)

PARAMETER		TEST CONDITIONS	MIN	TYP	MAX	UNIT
V_{IH}	High-level input voltage		$0.7 \times V_{DD}$		$V_{DD} + 0.3$	V
V_{IL}	Low-level input voltage		-0.3		$0.3 \times V_{DD}$	V
V_{OH}	High-level output voltage		4			V
V_{OL}	Low-level output voltage				0.8	V
f_{SCL}	SCL clock frequency				400	kHz

6.17 Non-Volatile Memory Characteristics

over operating free-air temperature range (unless otherwise noted)

PARAMETER		TEST CONDITIONS	MIN	TYP	MAX	UNIT
OTP				8		KB
OTP number of erase/write cycles		Erase using UV light			10	cycles
EEPROM		Programmable using SPI or OWI		89		bytes
		Number of bytes writeable by 8051		16		bytes
EEPROM erase/write cycles					1000	cycles

6.18 GPIO Characteristics

over operating free-air temperature range (unless otherwise noted)

PARAMETER		TEST CONDITIONS	MIN	TYP	MAX	UNIT
V _{IH}	High-level input voltage	R _{LOAD} ≥ 10 kΩ to V _{DD} or to 0 V	0.7 × V _{DD}		V _{DD} + 0.3	V
V _{IL}	Low-level input voltage	R _{LOAD} ≥ 10 kΩ to V _{DD} or to 0 V	−0.3		0.3 × V _{DD}	V
V _{OH}	High-level output voltage	I _{OH} = 1 mA	4			V
V _{OL}	Low-level output voltage	I _{OL} = −1 mA			0.8	V
I _{OH}	High-level output current	V _{OH} = 4.5 V			1	mA
I _{OL}	Low-level output current	V _{OL} = 0.5 V			1	mA
R _{PU}	Pullup resistance			160		kΩ

6.19 DAC1 and DAC2 Output Characteristics

over operating free-air temperature range (unless otherwise noted)

PARAMETER		TEST CONDITIONS	MIN	TYP	MAX	UNIT
Settling time		DAC Code 000h to FFFh step. Output is 90% of full scale. R _{LOAD} = 5 kΩ, C _{LOAD} = 500 pF			7	μs
Zero scale error		DAC code = 000h, I _{DAC} = 1.5 mA			46	mV
Full scale voltage		Output when DAC code is FFFh, I _{DAC} = −1.5 mA	4.85		4.95	V
Output current amplitude		DAC code = 0FFFh, DAC code = 0000h			1.5	mA
Short circuit source current		V _{DD} = 5 V, DAC code = 000h	−34		−10	mA
Short circuit sink current		V _{DD} = 5 V, DAC code = FFFh	10		34	mA
INL (best-fit line)			−3.5		3.5	LSB

6.20 Input Capture and Output Compare Port Characteristics

over operating free-air temperature range (unless otherwise noted)

PARAMETER		TEST CONDITIONS	MIN	TYP	MAX	UNIT
INPUT CAPTURE PORTS						
V _{IH}	High-level input voltage	R _{LOAD} ≥ 10 kΩ to V _{DD} or to 0 V	0.7 × V _{DD}		V _{DD} + 0.3	V
V _{IL}	Low-level input voltage	R _{LOAD} ≥ 10 kΩ to V _{DD} or to 0 V	−0.3		0.3 × V _{DD}	V
Input capture timer clock frequency		10_20_MHZ bit = 1		10		MHz
		10_20_MHZ bit = 0		20		
Input capture timer bits				16		bits
OUTPUT COMPARE PORTS						
V _{OH}	High-level output voltage	I _{OH} = 1 mA	V _{DD} − 1			V
V _{OL}	Low-level output voltage	I _{OL} = −1 mA			0.8	V
Output compare timer frequency		10_20_MHZ bit = 1		10		MHz
		10_20_MHZ bit = 0		20		
Output compare timer bits				16		bits
I _{OH}	High-level output current				1	mA
I _{OL}	Low-level output current				1	mA

6.21 Diagnostic Characteristics

over operating free-air temperature range (unless otherwise noted)

PARAMETER		TEST CONDITIONS	MIN	TYP	MAX	UNIT
	8051 software watchdog			500		ms
	Main clock normal operation range		35	40	45	MHz
VBRG_OV	Sensor supply overvoltage threshold		3.55	3.65	3.75	V
VBRG_UV	Sensor supply undervoltage threshold		2.9	3	3.11	V
Sensor _{OV}	Output overvoltage threshold for gain stage 1 and 2		2.4	2.5	2.6	V
Sensor _{UV}	Output undervoltage threshold for gain stage 1 and 2		0.7	.85	1	V
f _{capHigh}	Capacitive sensor interface clock high frequency fault threshold		1.5		2.5	MHz
f _{capLow}	Capacitive sensor interface clock low frequency fault threshold		30		50	kHz
	EEPROM CHG PUMP overvoltage threshold			14.65		V
	EEPROM CHG PUMP undervoltage threshold			11.45		V
	DAC loop back voltage gain		0.537	0.545	0.557	V/V
	Open wire leakage current 1	Open V _{DD} with pullup on VOUT1			2	μA
	Open wire leakage current 2	Open GND with pulldown on VOUT1			20	μA

6.22 SPI Timing Requirements

over operating free-air temperature range (unless otherwise noted)

		MIN	NOM	MAX	UNIT
t _{CSSCK}	\overline{CS} low to first SCK rising edge	25			ns
t _{SCKCS}	Last SCK rising edge to \overline{CS} rising edge	125			ns
t _{CSD}	\overline{CS} disable time	500			ns
t _{DS}	SDI setup time	25			ns
t _{DH}	SDI hold time	25			ns
t _{SDIS}	SDI fall/rise time			7	ns
t _{SCKR}	SCK rise time			7	ns
t _{SCKF}	SCK fall time			7	ns
t _{SCKH}	SCK high time	125			ns
t _{SCKL}	SCK low time	125			ns
t _{SDOE}	SDO enable time	15			ns
t _{ACCS}	SCK rising edge to SDO data valid	15			ns
t _{SDOD}	SDO disable time			15	ns
t _{SDOS}	SDO rise/fall time	3		11	ns

6.23 I²C Interface Timing Requirements

		MIN	NOM	MAX	UNIT
t_{STASU}	START condition setup time	500			ns
t_{STAHD}	START condition hold time	500			ns
t_{LOW}	SCL low time	1.25			μ s
t_{HIGH}	SCL high time	1.25			μ s
t_{RISE}	SCL and SDA rise time			7	ns
t_{FALL}	SCL and SDA fall time			7	ns
t_{DATSU}	Data setup time	500			ns
t_{DATHD}	Data hold time	500			ns
t_{STOSU}	STOP condition setup time	500			ns

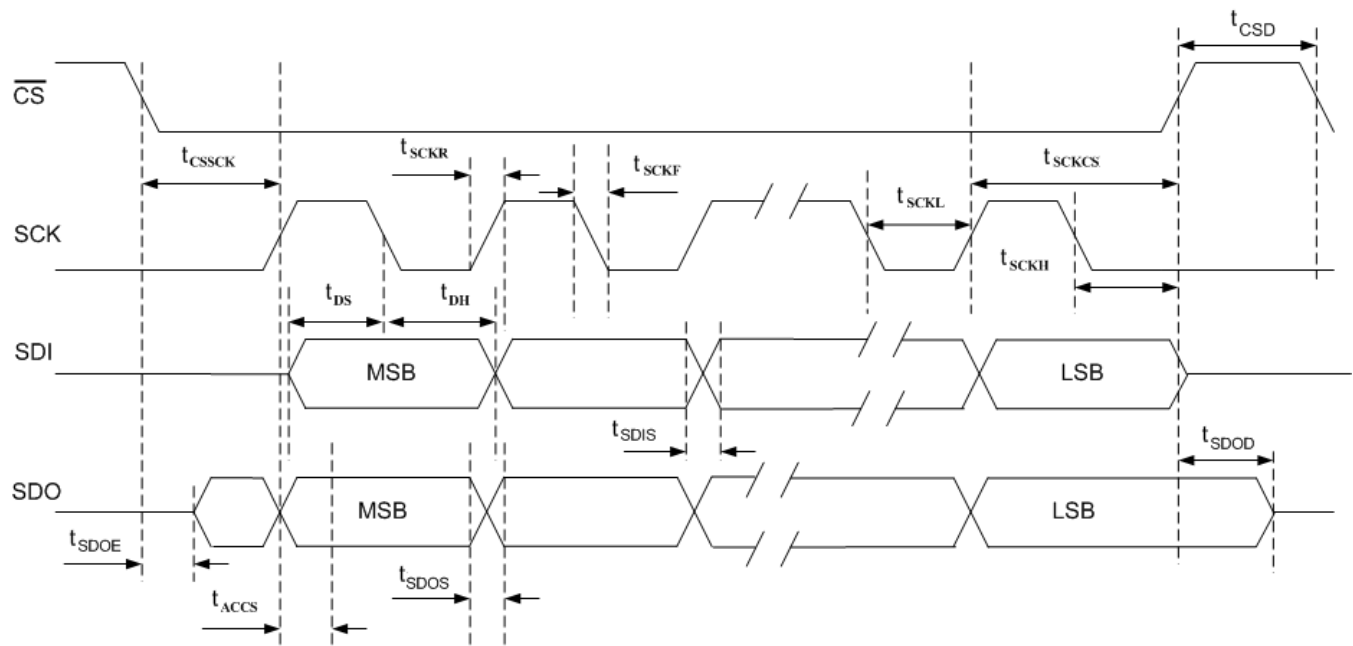

Figure 2. SPI Timing

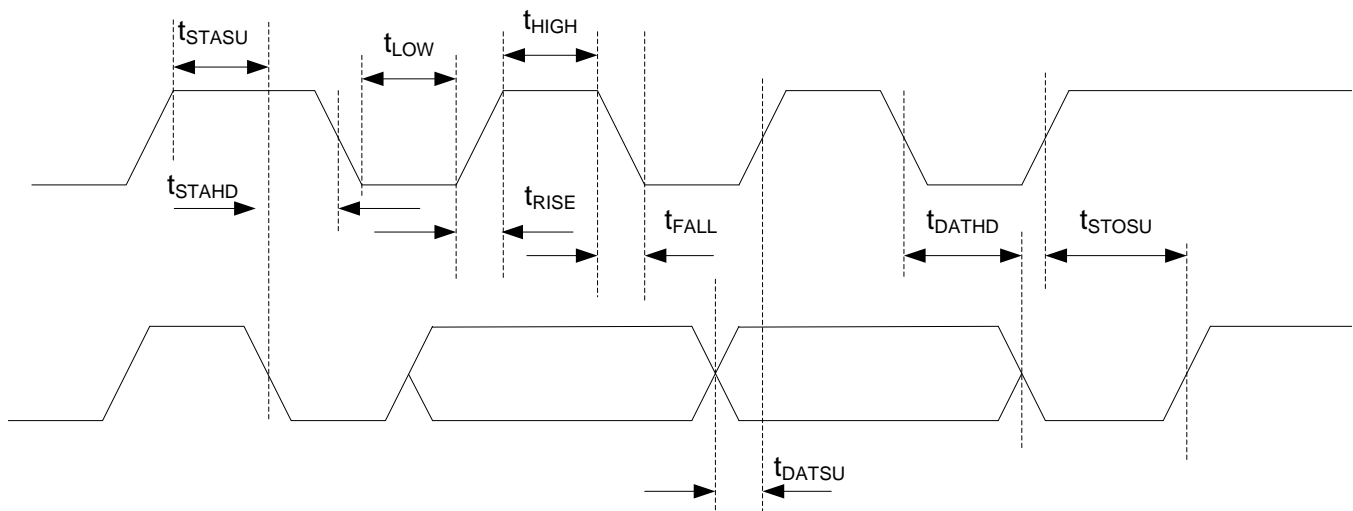
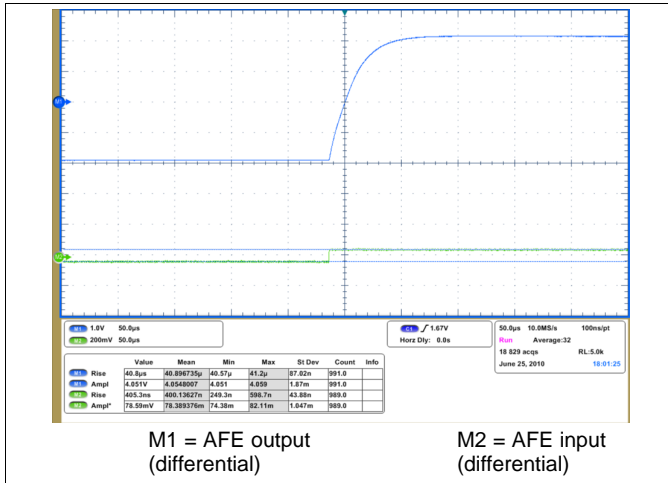

Figure 3. I²C Timing

6.24 Typical Characteristics



M1 = AFE output (differential)
M2 = AFE input (differential)

Figure 4. Typical Step Response Time

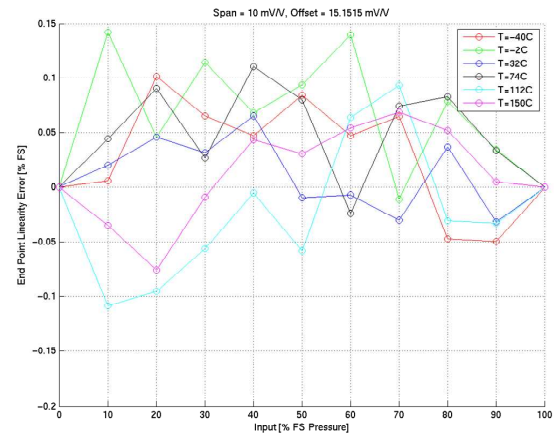

Figure 5. Typical %NL Temperature Drift Characteristics

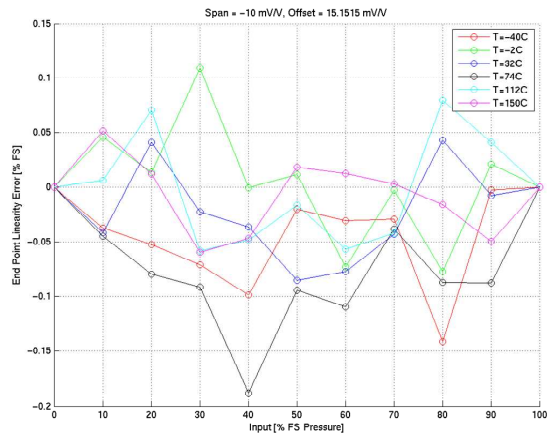

Figure 6. Typical %NL Temperature Drift Characteristics

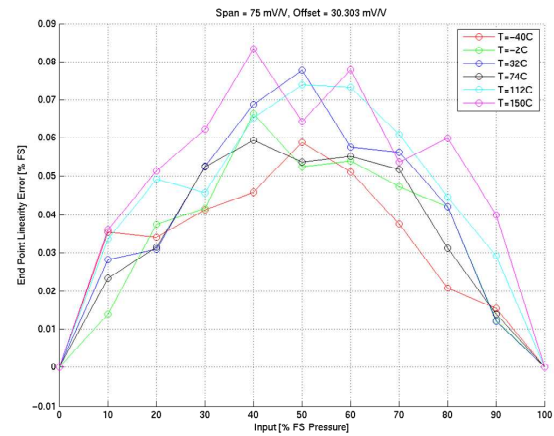

Figure 7. Typical %NL Temperature Drift Characteristics

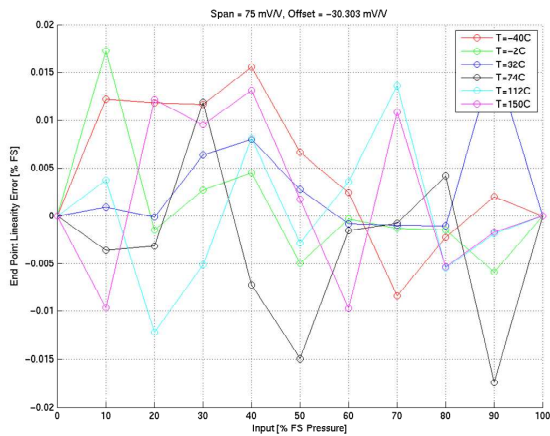

Figure 8. Typical %NL Temperature Drift Characteristics

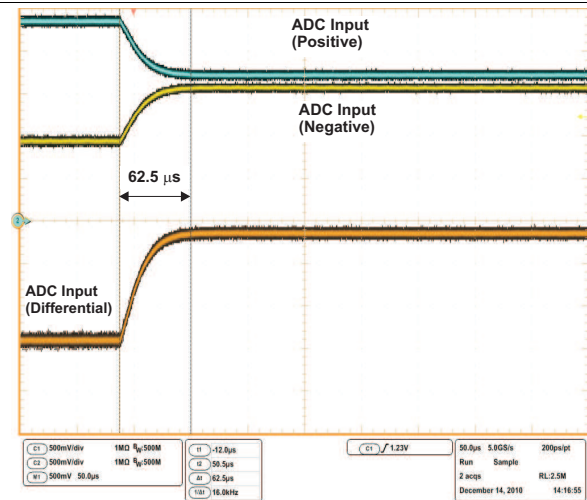

Figure 9. Typical Step Response Time of Capacitive AFE

Typical Characteristics (continued)

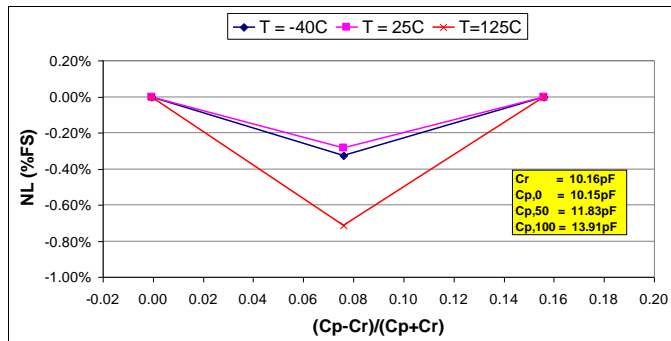

Figure 10. Linearity (%FS)

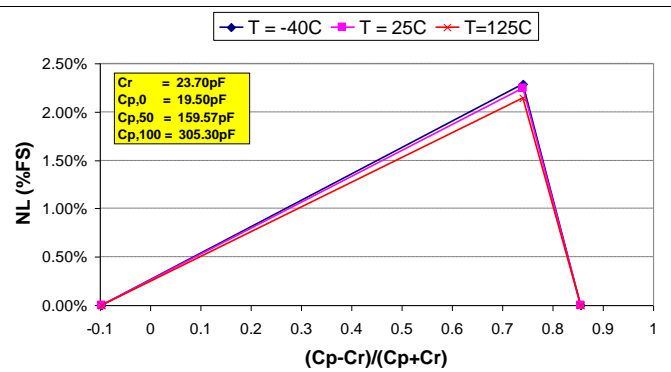

Figure 11. Linearity (%FS)

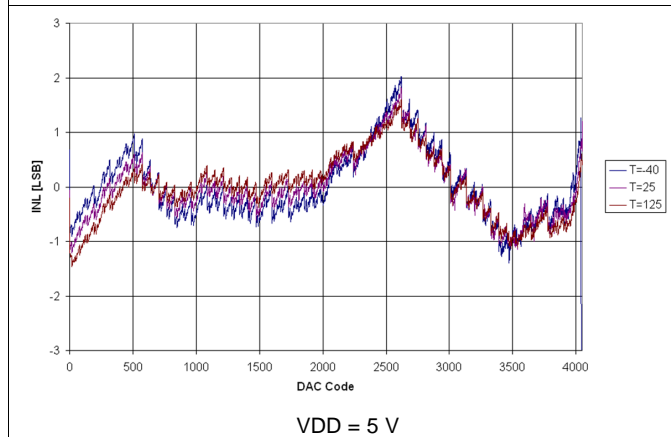

Figure 12. DAC1, INL vs DAC Code

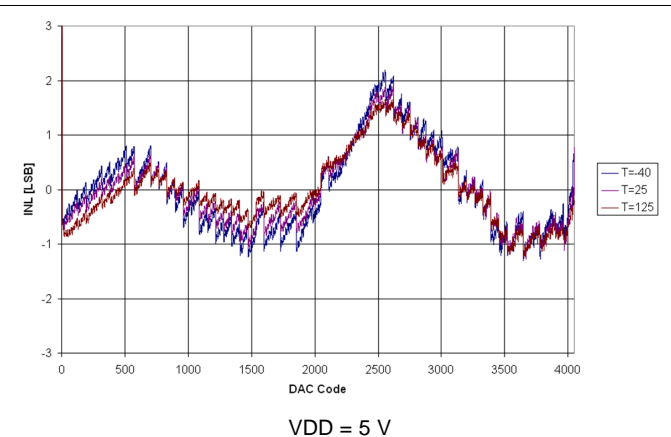

Figure 13. DAC2, INL vs DAC Code

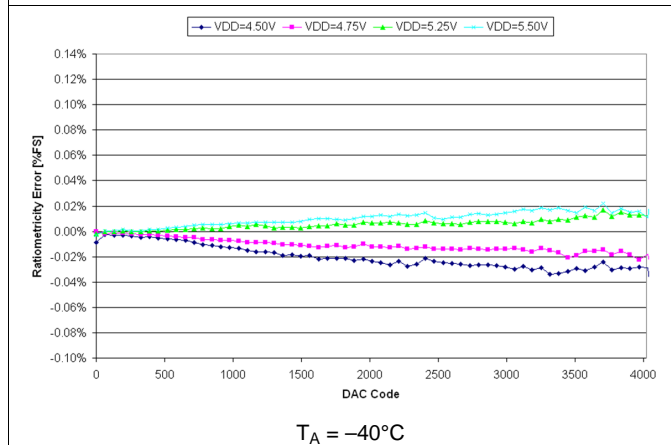

Figure 14. DAC1, Ratiometricity vs DAC Code

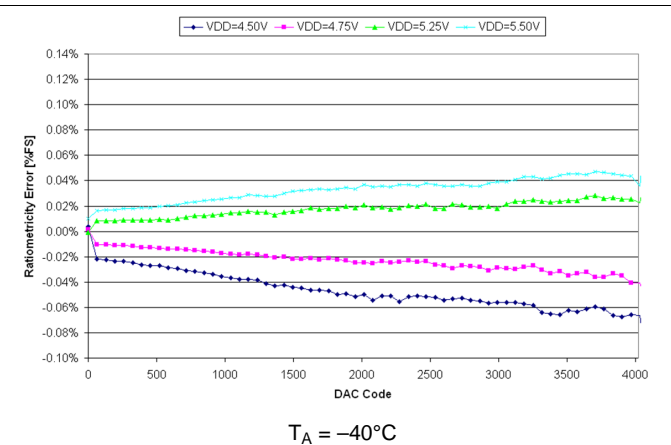

Figure 15. DAC2, Ratiometricity vs DAC Code

Typical Characteristics (continued)

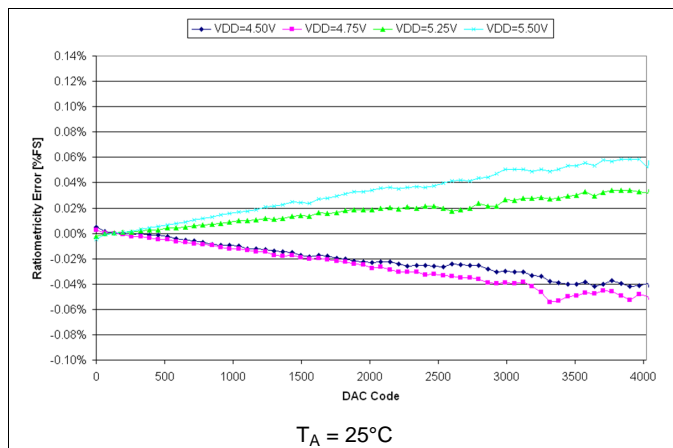

Figure 16. DAC1, Ratiometricity vs DAC Code

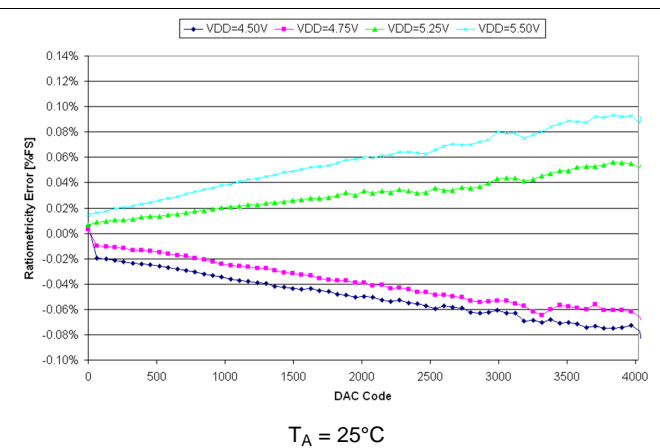

Figure 17. DAC2, Ratiometricity vs DAC Code

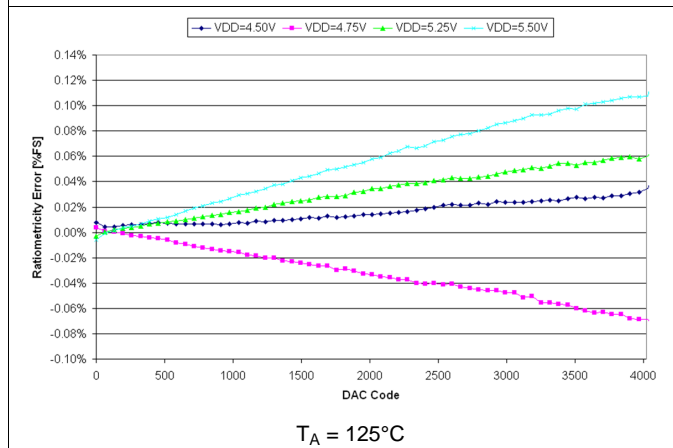

Figure 18. DAC1, Ratiometricity vs DAC Code

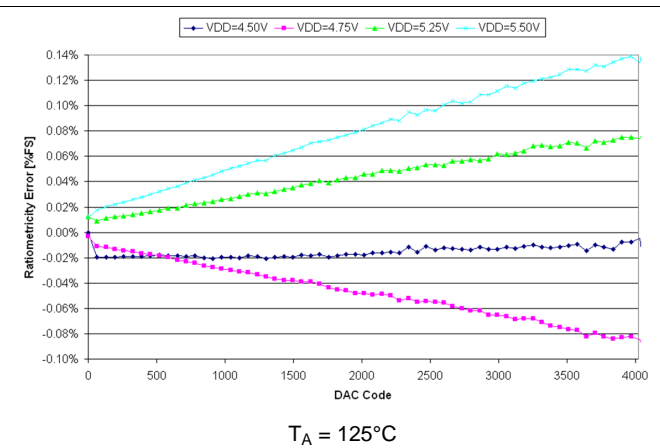

Figure 19. DAC2, Ratiometricity vs DAC Code

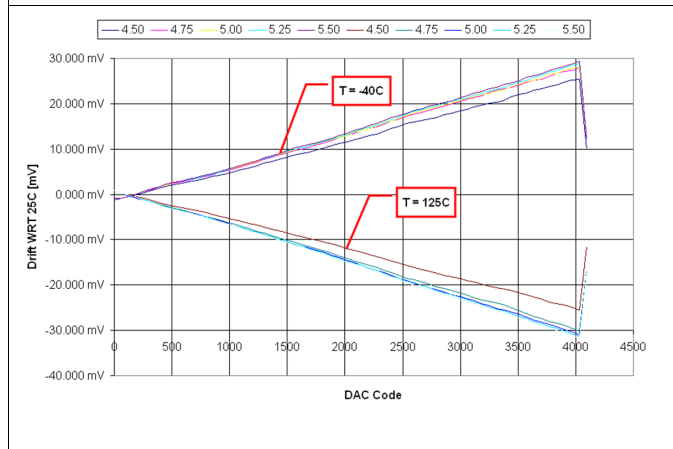

Figure 20. DAC1 Temperature Drift (mV)

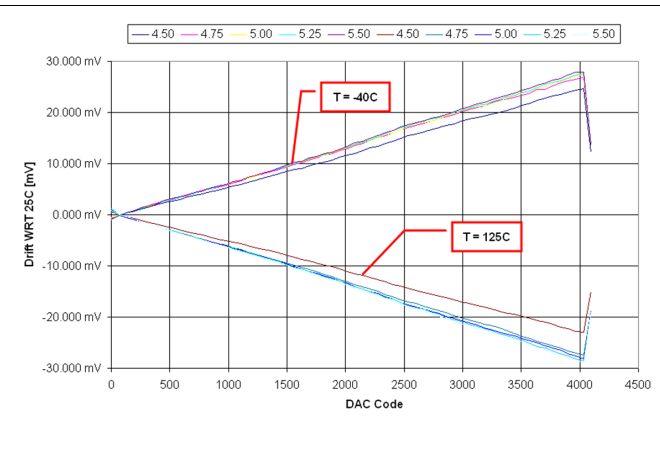
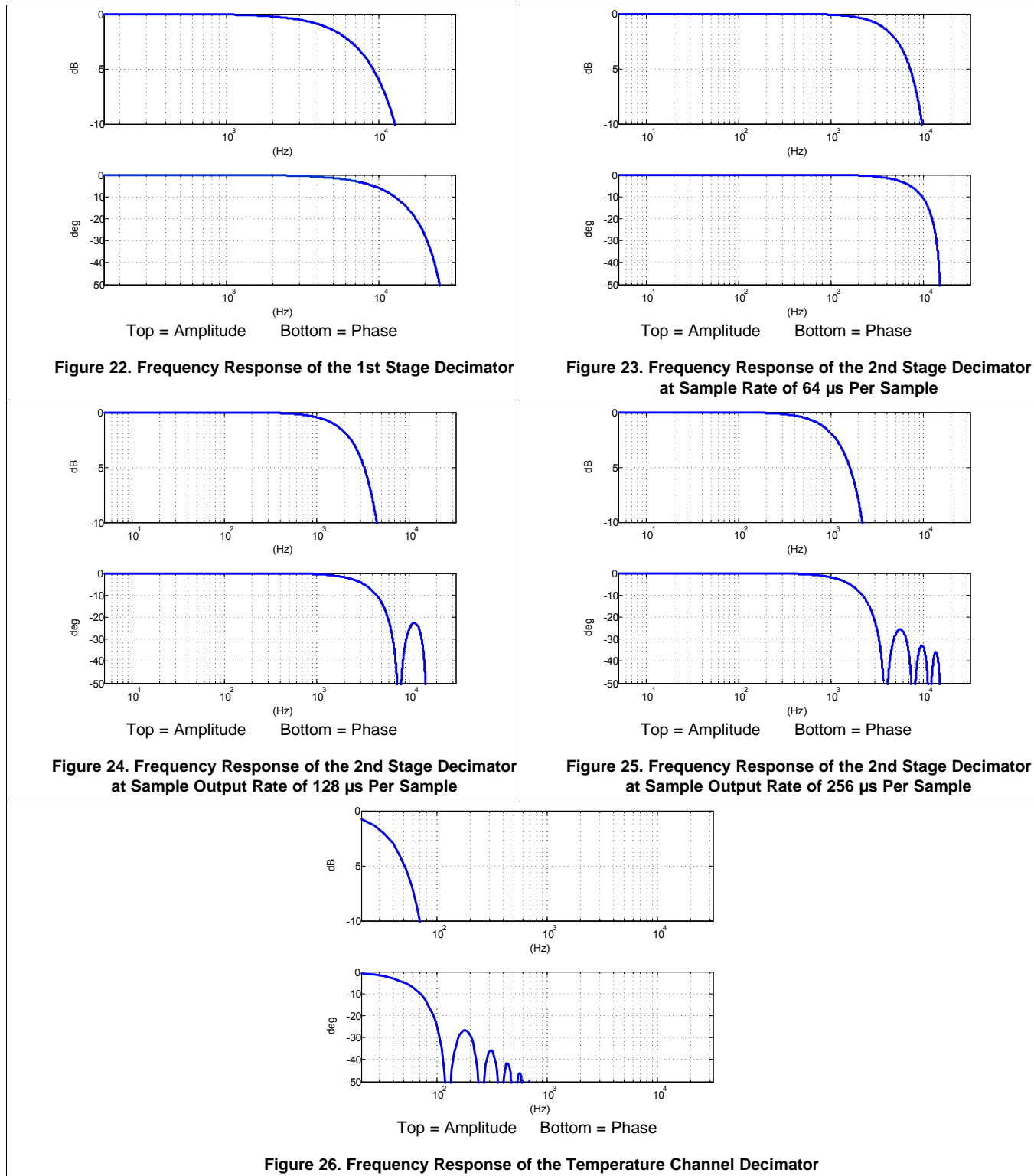

Figure 21. DAC2 Temperature Drift (mV)

Typical Characteristics (continued)



7 Detailed Description

7.1 Functional Block Diagram

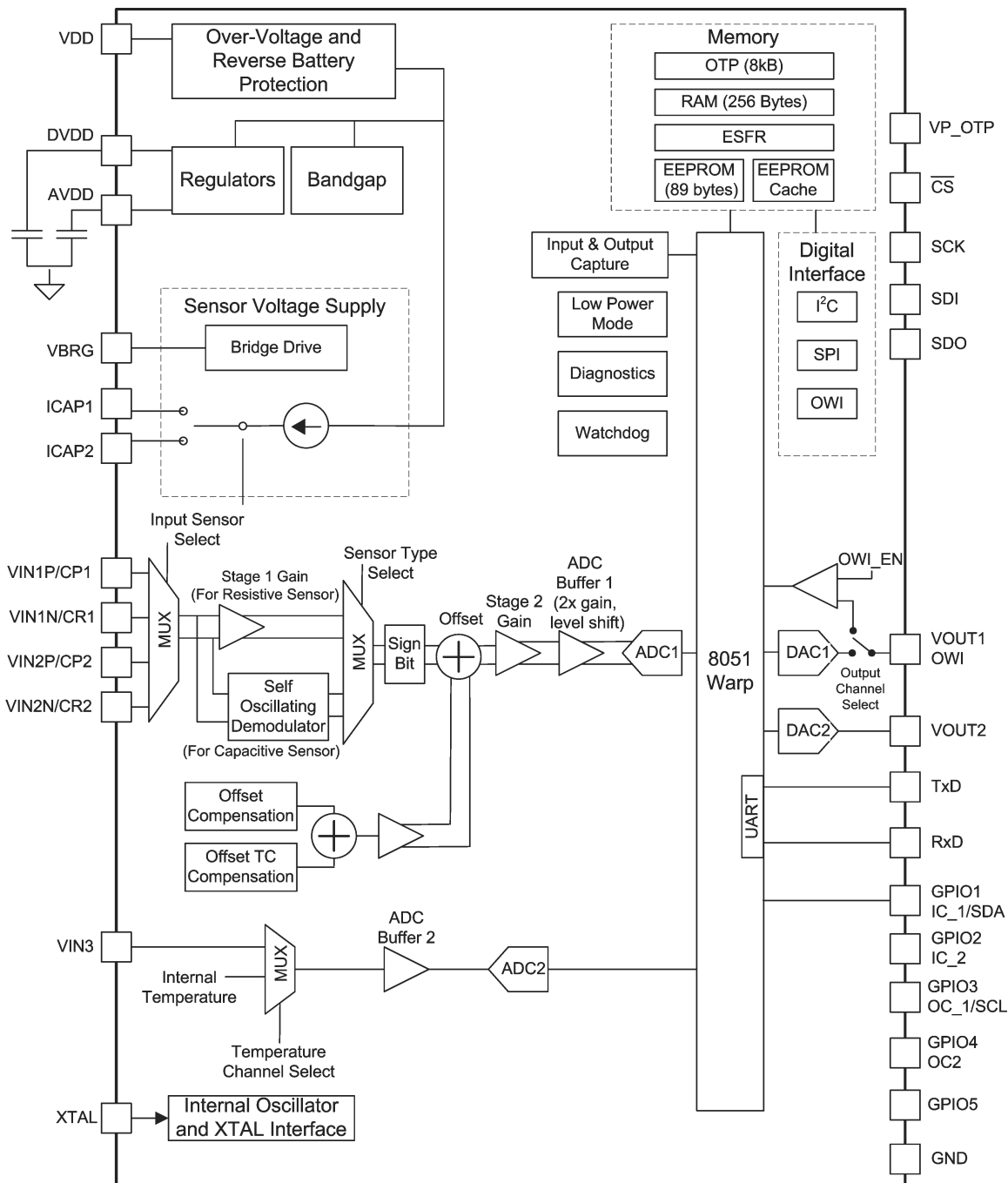

7.2 Feature Description

7.2.1 Overvoltage and Reverse Voltage Protection Block

The PGA400-Q1 device includes an Overvoltage and Reverse Voltage Protection block. This block protects the device from overvoltage and reverse-battery conditions on the external power supply. In this block, a control circuit monitors the input supply line for reverse-battery, and overvoltage fault conditions protect the device if these voltage conditions occur on the external power supply.

Feature Description (continued)

7.2.2 Linear Regulators and Bandgap + Current Blocks

The PGA400-Q1 device has two precision, low-drift bandgap supply-voltage references for other blocks of the device. One bandgap provides the reference voltage for the internal linear regulators that supply the AVDD and DVDD regulators. The other bandgap reference provides the voltage reference for the all the other internal circuitry, including sensor-supply regulators, sensor offset compensation, and others.

The PGA400-Q1 device has two main linear regulators: the AVDD regulator and DVDD regulator. The AVDD regulator provides the 3.3-V voltage source for internal analog circuitry while the DVDD regulator provides the 3.3-V regulated voltage for the digital circuitry. The user must connect 100-nF bypass capacitors on both the AVDD and DVDD pins of the device.

Figure 27 shows the power-on reset (POR) sequence for the AVDD and DVDD regulators with respect to the voltage applied to the V_{DD} pin.

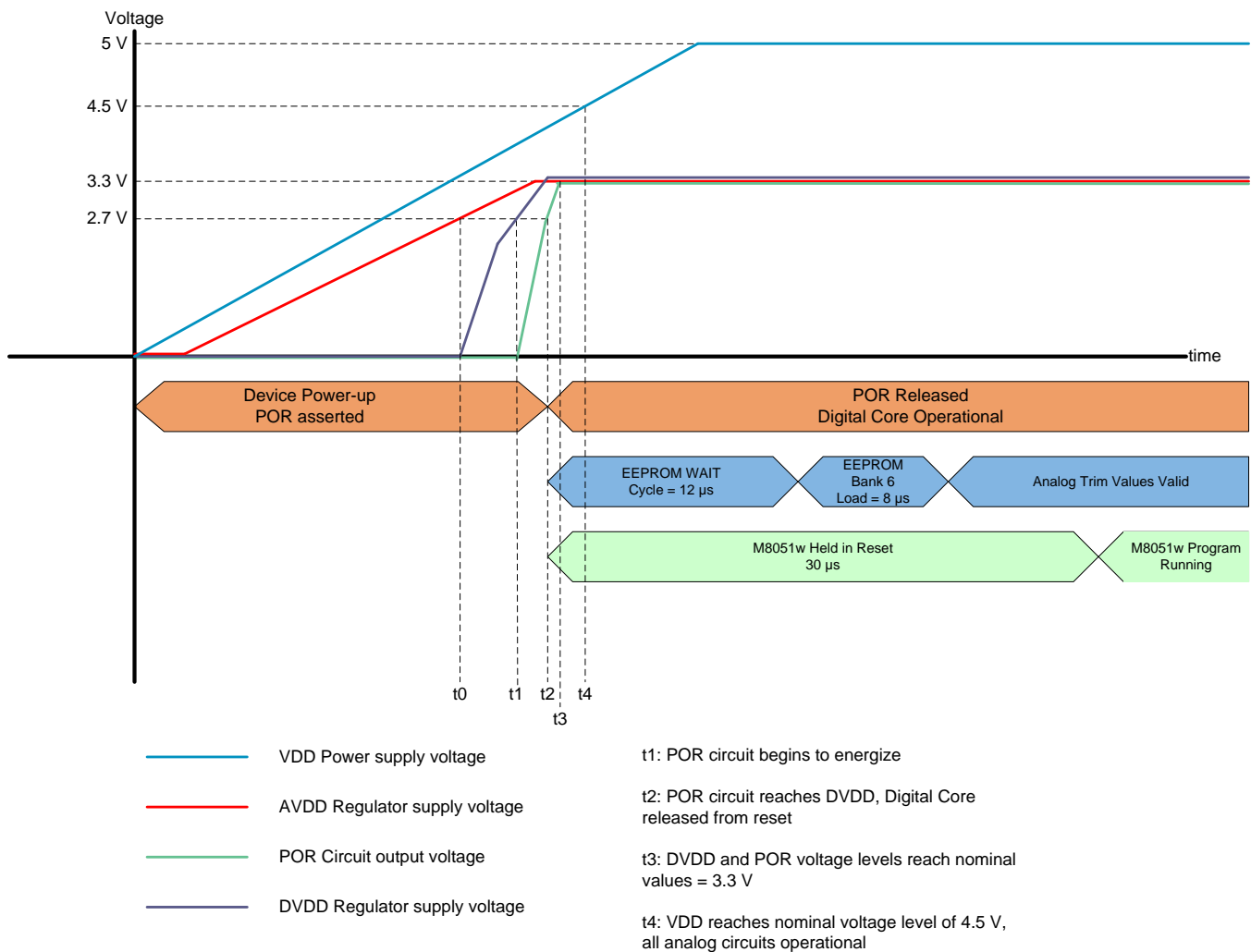

Figure 27. POR Sequence Diagram

Feature Description (continued)

7.2.3 Internal OSC/XTAL I/F Block

The device has an internal, 40-MHz oscillator, which provides the internal clocks required by default. The device can also be configured to use an external 40-MHz crystal as a time base through the XTAL_EN bit in the Sensor Control Register (SENCTRL). When the XTAL_EN bit is set high, the internal 40-MHz oscillator is disabled and control of the main system clock is driven by the external clock source connected to the XTAL pin.

NOTE

Do not use the XTAL pin as an output for sourcing a clock signal to other devices.

7.2.4 Sensor Voltage Supply Block

The Sensor Voltage Supply block of the PGA400-Q1 device supplies both the VBRG output for resistive bridge sensors and the ICAP supply for capacitive sensors.

7.2.4.1 VBRG Supply for Resistive Bridge Sensors

The sensor supply in PGA400-Q1 is simply a linear voltage regulator. The essential schematic is shown in Figure 28. The external supply voltage applied to the VDD pin first passes through the Overvoltage & Reverse Supply protection circuit (OVISP) to produce the internal protected VDD supply (VDD_INT). This voltage is then regulated down to 3.3 V to produce the sensor supply voltage on the VBRG pin. The reference used by the regulator is the precise internal temperature independent band-gap reference. The regulated output is referred to the reference ground (REF_GND), which is common to the band-gap and ADC reference generator circuits.

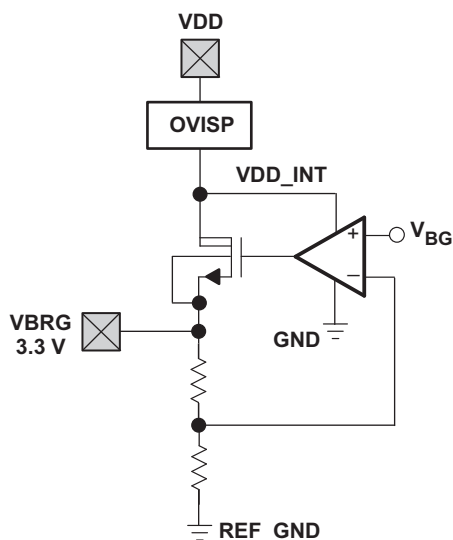
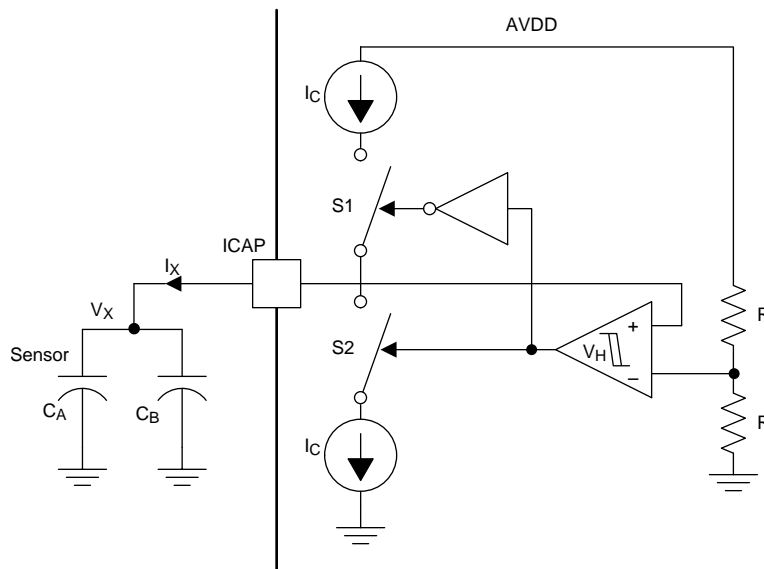

Figure 28. VBRG Supply

7.2.4.2 ICAP Supply for Capacitive Sensors

Figure 29 shows a functional schematic of the capacitive-sensor drive circuit. The common node of the sensor capacitors is tied to the ICAP pin. At this point, the current and voltage are referred to as I_x and V_x respectively. To understand the operation of the drive circuit as a standalone circuit, deal with the other sensor pins as if they were tied to ground because the sensor-signal measurement circuit regulates the voltage at these nodes. This circuit is essentially a relaxation oscillator where the capacitance of the sensor, the charging current (I_C), and the comparator hysteresis (V_H) determine the frequency of oscillation.

Feature Description (continued)

Figure 29. Capacitive Sensor Drive Circuit

To illustrate the circuit operation, the sensor voltage V_X is initially set to 0 V. In this state, the positive terminal of the hysteretic comparator is lower than the negative reference terminal, producing a logical zero at the output. This results with switch S2 open and switch S1 closed, allowing the upper current source to charge the sensor capacitance. Figure 30 shows the resulting waveform. Use Equation 1 to calculate the linear ramp-up slope of the voltage, V_X :

$$\frac{dV_X}{dt} = \frac{I_C}{C_A + C_B} \quad (1)$$

After V_X is charged up to the high threshold of the comparator, the circuit inverts the states of switches S1 and S2. By closing S2 and opening S1 the lower current source begins to discharge the sensor capacitances, making V_X ramp down with an equal but opposite rate as before. When V_X reaches the low threshold of the comparator, the circuit again inverts the states of the switches and returns to the positive charging state. This process of charging and discharging repeats with a period characterized as shown in Equation 2.

$$T = \frac{2 \cdot V_H}{I_C} \cdot (C_A + C_B) \quad (2)$$

Both the comparator hysteresis voltage V_H and capacitor charging current I_C are configurable to allow control of the oscillation period for a particular sensor. Bits CV[1..0] in the Capacitive Sensor Settings Register (CAPSEN) can be used to set V_H . V_H can be set between 100 mV and 700 mV with four possible steps. Bits CI[2..0] in the Capacitive Sensor Settings Register (CAPSEN) can be used to set I_C , with possible values between 5 μ A and 22 μ A with eight possible steps.

NOTE

For capacitive sensors, one common set of configurations registers are implemented. If different settings are needed for the two capacitive sensors, then the software must dynamically update the register values.

Feature Description (continued)

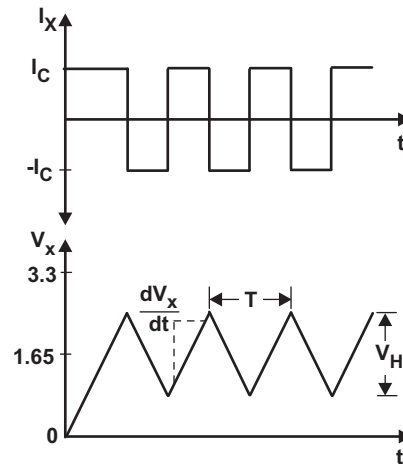

Figure 30. Capacitive Sensor Drive Waveforms

7.2.5 Internal Temperature Block and External Temperature Sensing

The device has the ability to perform temperature compensation via an internal or external temperature sensor. The user can select the source of the sensor with the TEMP_SEN bit in the Sensor Control Register (SENCTRL). When the TEMP_SEN bit is set to 0 the internal temperature sensor is used, and when the TEMP_SEN bit is set to 1 the external temperature sensor is used.

7.2.5.1 Internal Temperature Sensor

The device contains an internal temperature sensor which is converted by an ADC and made available to the 8051 microprocessor so that appropriate temperature compensation algorithms can be implemented in software. The nominal relationship between the device temperature and the ADC Code is shown in [Equation 3](#).

$$\text{ADC Code} = 2.8 \times \text{TEMP} - 80, \text{TEMP is temperature in } ^\circ\text{C}. \quad (3)$$

7.2.5.2 External Temperature Sensor

The device accepts a temperature from an external temperature sensor via the VIN3 pin. The input temperature needs to be in the form of a voltage.

NOTE

The Offset TC block has been configured to operate with the internal temperature sensor transfer function. If an external temperature sensor is used and the user needs to use Offset TC compensation, then the temperature-to-voltage transfer function of the external temperature sensor has to match the transfer function of the internal temperature sensor.

7.2.6 Using the Analog Front End

The PGA400 can be used to interface with Resistive Bridge Sensors as well as Capacitive Sensors. To enable multiple sensors of either type a series of muxes are used. These muxes are controlled by the Sensor Control Register (SENCTRL) and Capacitive Sensor Setting Register (CAPSEN).

The SEN_TYP bit of the Capacitive Sensor Settings Register (CAPSEN) configures the device to be used with either resistive or capacitive sensor types. When this bit is set to 0, the device is configured for capacitive sensors and when the bit is set to 1 the device is configured for resistive bridge sensors. When either front-end is selected, the other option is disabled and placed in a low quiescent current state.

Feature Description (continued)

The Analog Front End (AFE) can also be configured to measure two sensors sequentially. This is controlled via the SEN_CHNL bit in the Sensor Control Register (SENCTRL). When this bit is set to 0, the analog MUX at the input of the AFE is switched to pass the signals present at VIN1P and VIN1N pins. For capacitive sensors, the capacitive sensor drive current is also applied to the ICAP1 pin. When this bit is set to 1, the VIN2P, VIN2N and ICAP2 pins become active. The SEN_CHNL bit also controls which External Special Function Registers (ESFRs) are applied to the Stage 1 Gain, Stage 2 Gain, Offset, Offset TC and the Sign bits.

In addition the sensor supply regulator can be independently enabled or disabled via the VBRG_EN bit in the Sensor Control Register (SENCTRL). This allows the VBRG 3.3 V output to be used with external temperature sensors while the AFE is configured in capacitive sensor mode.

7.2.7 Stage 1 Gain Block

When the device is configured to interface with resistive sensors, the first gain block that the signal passes through in the AFE is the Stage 1 Gain block. This gain block is designed with precision, low drift, low flicker noise amplifiers.

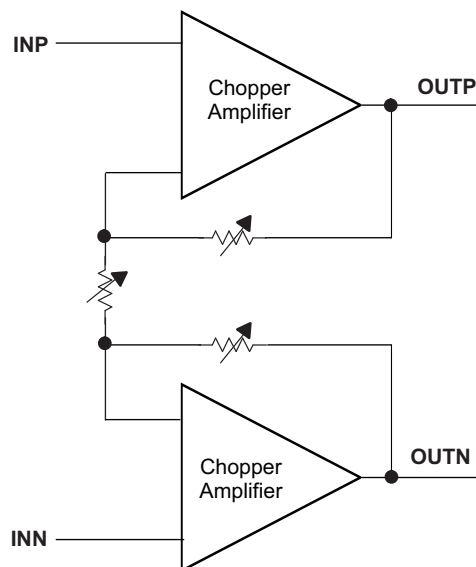

Figure 31. Stage 1 Gain Schematic

The gain of this stage is adjustable to accommodate sensors with a wide-range of signal spans and can be set from 3V/V to 51V/V in 8 possible steps. The Stage 1 Gain has two independent registers, Sensor 1 Gain Register (SEN1GAIN) and Sensor 2 Gain Register (SEN2GAIN), so that two different resistive sensors can be connected with different gain settings. For Stage 1 Gain settings use either the S1_G1 bits or the S2_G2 bits in the registers mentioned above. The gain setting that is used depends on the SEN_CHNL bit in Sensor Control Register (SENCTRL).

[Table 2](#) outlines the ranges of resistive bridge sensor characteristics that are compatible.

Table 2. Target Resistive Bridge Sensors

PARAMETER	CONDITION	MIN	TYP	MAX	UNIT
Resistive bridge resistance	$-40^{\circ}\text{C} \leq T_A \leq 150^{\circ}\text{C}$	2		20	k Ω
Resistive bridge resistance TC		-350		4800	PPM/ $^{\circ}\text{C}$
Resistive bridge offset (compensated in analog front end)	$T_A = 25^{\circ}\text{C}$	-33		33	mV/V
Resistive bridge offset TC (compensated in analog front end)		-40		40	$\mu\text{V}/\text{V}/^{\circ}\text{C}$
Resistive bridge span	$T_A = 25^{\circ}\text{C}$	1.4		75	mV/V

7.2.8 Self Oscillating Demodulator Block

Figure 32 shows an essential schematic of the capacitive sensor signal measurement circuit. The Sensor Voltage Supply block is depicted only as a functional block called Sensor Drive that provides the sensor drive current via the ICAPx pin and the clock signals S₁ and S₂ that are used by the synchronous demodulator in the measurement circuit. As with the ICAP supply circuitry the demodulator block circuitry toggles between two states during normal operation. In one state the S₁ switches are closed while the S₂ switches are open and in the other state the S₁ switches are open while the S₂ switches are closed.

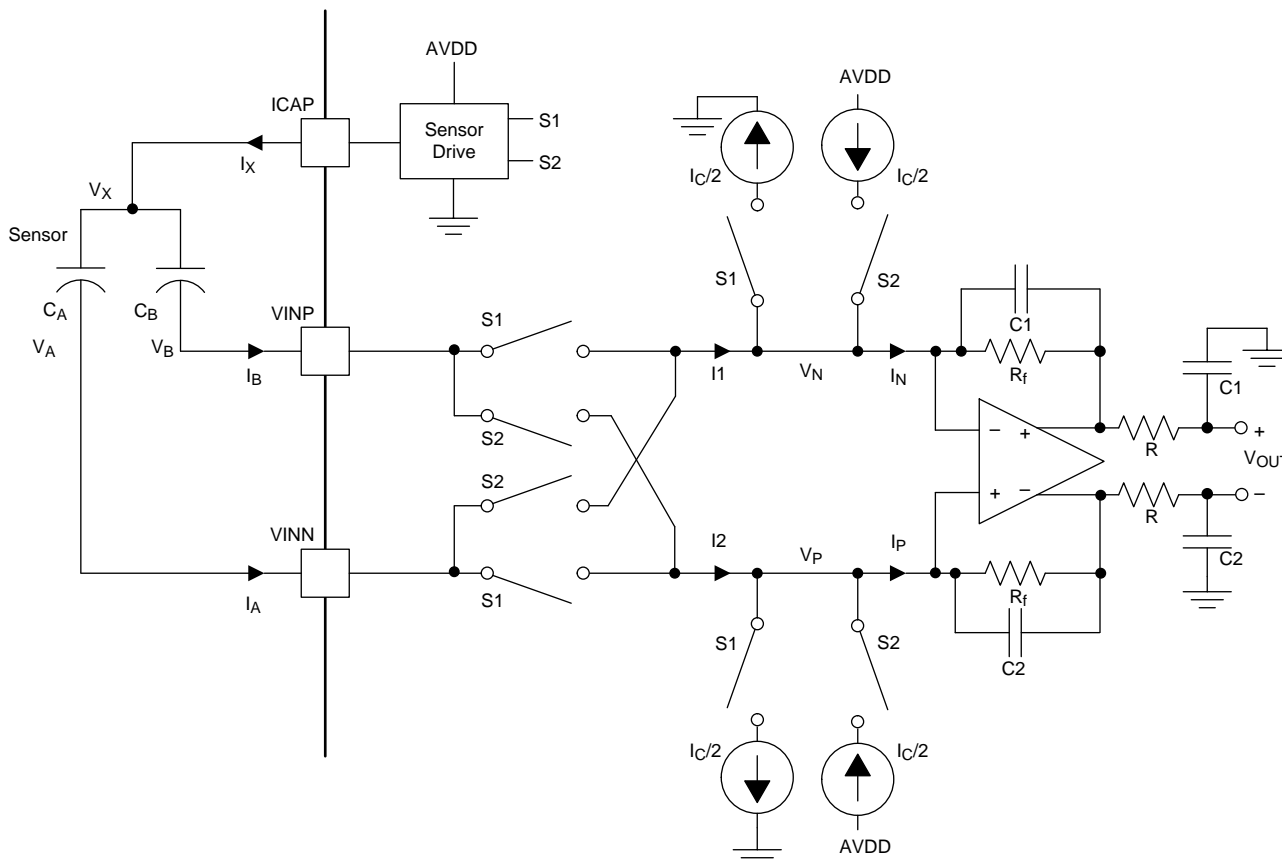

Figure 32. Capacitive Sensor Signal Measurement Circuit

To illustrate the operation of the circuit, assume that it has been given sufficient time to settle and is now operating in its normal steady-state mode of operation. During the positive charging phase, I_x is positive and the S₁ switches are closed. In this state, the amplifier seeks to regulate its input terminals to the same potential, creating a virtual ground at the VINP and VINN pins. This allows Equation 4 to be expressed for I_x as:

$$I_x = (C_A + C_B) \cdot \frac{dV_x}{dt} \tag{4}$$

In a similar manner, Equation 5 describes the currents through C_A and C_B and the difference between these currents.

$$I_A = C_A \cdot \frac{dV_x}{dt} \tag{5}$$

$$I_B = C_B \cdot \frac{dV_x}{dt} \tag{6}$$

$$\Delta I = (I_A - I_B) = (C_A - C_B) \cdot \frac{dV_x}{dt} = I_x \cdot \left(\frac{C_A - C_B}{C_A + C_B} \right) \tag{7}$$

The drive current is split between the capacitors in proportion to their relative difference. Measuring ΔI provides a means to infer the value of the difference in capacitance ($C_A - C_B$) or the value of one of the capacitors if the other is known. Also, driving the sensor with a current source and measuring the resulting difference in current has the benefit of being fully differential and thus less susceptible to common-mode disturbances and non-idealities. Note that the expressions for I_A and I_B may be rewritten in terms of common-mode and differential-mode components in [Equation 8](#) and [Equation 9](#).

$$I_A = \frac{I_X}{2} + \frac{\Delta I}{2} \quad (8)$$

$$I_B = \frac{I_X}{2} - \frac{\Delta I}{2} \quad (9)$$

The capacitive sensor signal measurement circuit extracts and amplifies ΔI . [Figure 33](#) illustrates the current waveforms at different points in the circuit of [Figure 32](#). The currents into and out of the sensor are shown on axis (a). Initially, the circuit is in the discharge phase where I_X is negative and S_2 switches are closed. After some time, the state switches to the charge phase where the S_1 switches are closed. This process of changing the state of the circuit continues periodically with a frequency set by the sensor drive circuit.

During each half cycle the I_X current is split into the individual capacitor currents I_A and I_B . As shown in [Figure 33\(b\)](#), while the S_1 switches are closed $I_2 = I_A$ and $I_1 = I_B$, but when the S_2 switches are closed the currents are inverted such that $I_2 = I_B$ and $I_1 = I_A$. Because the sign of I_X is also changing, the difference between I_2 and I_1 remains constant and equal to ΔI (ignoring the glitches that occur at phase transitions).

While the S_1 switches are closed, half the sensor drive current ($I_C/2$) is subtracted from I_2 and I_1 and while the S_2 switches are closed, half the sensor drive current is added to them. This removes the cycle-to-cycle offset in [Figure 33\(b\)](#), delivering the DC currents I_P and I_N to the trans-impedance amplifier, as shown in [Figure 33\(c\)](#) where $I_P - I_N = \Delta I$. For low frequency signals, the output voltage of the amplifier is shown in [Equation 10](#).

$$V_{out} = R_f \cdot \Delta I = R_f \cdot I_C \cdot \left(\frac{C_A - C_B}{C_A + C_B} \right) \quad (10)$$

For a given sensor, the drive current I_C should be adjusted to keep $V_{OUT} < 1.65$ V over the expected operating conditions of the sensor to avoid saturating the ADC input.

NOTE

for some types of wide span sensors, it may be necessary to reduce the gain set by the value of R_f in the transimpedance amplifier. The drive current I_C and feedback resistance R_f can be adjusted via Capacitive Sensor Settings Register (CAPSEN).

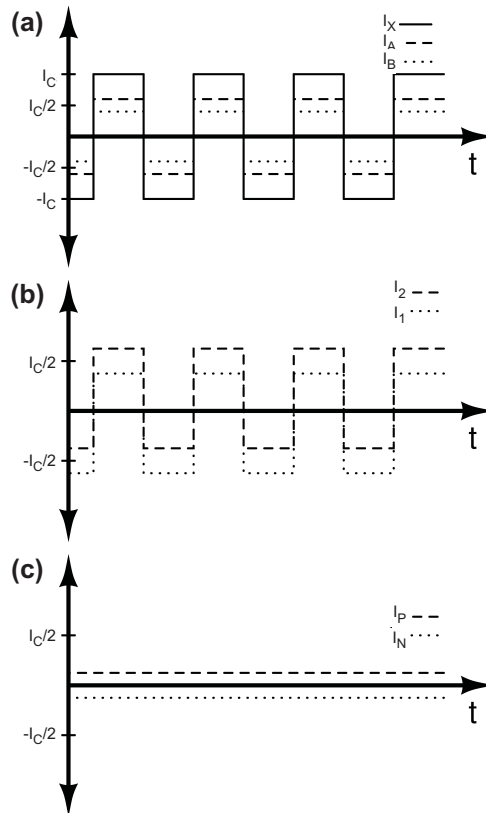

Figure 33. Current Waveforms in the Sensor Signal Measurement Circuit

This process of changing the state of the circuit continues periodically with a frequency set by the sensor drive circuit described in Equation 11.

$$f = \frac{I_C}{2 \cdot V_H \cdot (C_A + C_B)} \quad (11)$$

Because the operational amplifier must settle at each switching cycle, there is an upper bound imposed on the sensor drive frequency. Using a minimum half-cycle time of seven times the operational amplifier settling time and a minimum operational amplifier GBW of 7 MHz, shows the following upper bound on the switching frequency:

$$f_{MAX} \leq 800 \text{ kHz}$$

In reality, there are glitches and residual up-converted noise in the I_P and I_N signals. For this reason, the trans-impedance amplifier has a low-pass characteristic, with one pole set by the feedback elements R_f and C_f , and a second pole at the output set by R and the same capacitance C_f . For most sensor types, R is equal to R_f . In this case, the frequency dependent trans-impedance may be expressed as shown in Equation 12.

$$Z(s) = \frac{R_f}{(1 + s \cdot R_f \cdot C_f)^2} \Omega \quad (12)$$

Where with nominal values of $R_f = 625 \text{ k}\Omega$ and $C_f = 16 \text{ pF}$, the corner frequency of the filter is 15.9 kHz. If the minimum permissible ripple suppression is chosen to be 40 dB at the switching frequency, and the corner frequency is rounded up to 20 kHz, illustrates the lower bound on the switching frequency:

$$f_{min} \geq 200 \text{ kHz}$$

For a given sensor, the drive circuit comparator hysteresis value V_H and the drive current I_C should be chosen so that the switching frequency remains within the range of 200 to 800 kHz as the sensor capacitance varies within its expected range.

Table 3 outlines the ranges of compatible capacitive bridge sensor characteristics.

Table 3. Target Capacitive Sensors

PARAMETER	TEST CONDITIONS	MIN	MAX	UNIT
Capacitive sensor initial capacitance (C _p + C _r)		10	310	pF
Capacitive sensor offset (compensated in analog front end)	(C _{p,0} – C _{r,0})/(C _{p,0} + C _{r,0})	–0.16	0.16	
Capacitive sensor span	(C _{p,100} – C _{r,100})/(C _{p,100} + C _{r,100})	0.04	1.00	
Capacitive sensor offset TC			0.8	%C _{v,0} / °C

7.2.8.1 Configuring the Capacitive Sensor Interface for a Particular Sensor

A general procedure for choosing what values to use for the capacitive sensor drive current (I_C), drive voltage comparator hysteresis (V_H) and trans-impedance (R_f) is the following:

- Find the values of I_C that maintain V_{OUT} below 1.65 V for the maximum sensor span plus offset
- Using the largest allowed value for I_C and the minimum and maximum total sensor capacitance (C_A+C_B), find a value for V_H that maintains the switching frequency within the range of 200 kHz to 800 kHz
- If the frequency constraints cannot be met, reduce the value of I_C and iterate to find an optimal solution

This procedure can be applied to configure the capacitive sensor interface with total capacitances ranging from 10 pF to 300 pF and span plus offset ratios (C_A – C_B) / (C_A + C_B) up to 0.36.

The Stage 1 gain has two independent registers for the two sensors that can be potentially connected. The Stage 1 gain setting used depends on the SEN_CHNL bit in the Sensor Control Register.

7.2.9 Sign Bit Block

The device has a sign bit block that is used for span sign compensation. This block is used to change the polarity of the first stage output, and it is implemented through the use of four switches. The switches are set through the use of the S1_INV bit for sensor 1 and the S2_INV bit for sensor 2 in the Sensor Control Register (SENCTRL). There are two independent sign bit settings to accommodate configuring the polarity for two independent sensors. The sensor sign bit used is based on the SEN_CHNL bit in the Sensor Control Register.

7.2.10 Offset and Offset TC Compensation Blocks

The offset compensation circuit can be configured to null out the sensor offset and first order offset temperature coefficient. The offset compensation block is located between the Sign Bit block and the Stage 2 Gain block as shown in the [Figure 1](#).

The offset compensation, V_{COMP}, is a value that is subtracted from the output of the sign bit block. This offset provides a means to null the sensor offset prior to Stage 2 Gain. The offset compensation circuit block provides ten bits of zero-order compensation and six bits of first-order TC compensation.

A more detailed block diagram of the offset compensation subsystem is shown in [Figure 34](#). As shown V_{comp} is derived from two references, V_{BG} and V_{PTAT}. Where V_{BG} is a precise temperature independent band-gap reference voltage, and V_{PTAT} is a proportional-to-absolute-temperature voltage. In PGA400-Q1, the gains in the offset compensation circuitry (A, B, C) have been designed assuming the following characteristics about the reference signals:

$$V_{BG} = 1.23 \text{ V} \quad (13)$$

$$V_{PTAT}(T) = k_{PTAT} \times (T + 273) + \xi_{PTAT} \quad (14)$$

where

$$k_{PTAT} = 3.7 \text{ mV/}^\circ\text{C} \text{ and } \xi_{PTAT} = -47 \text{ mV} \quad (15)$$

NOTE

If an external temperature sensor is used, the signal applied to the VIN3 pin must have the same temperature dependency as the above mentioned V_{PTAT} signal or else the offset TC compensation does not work as intended.

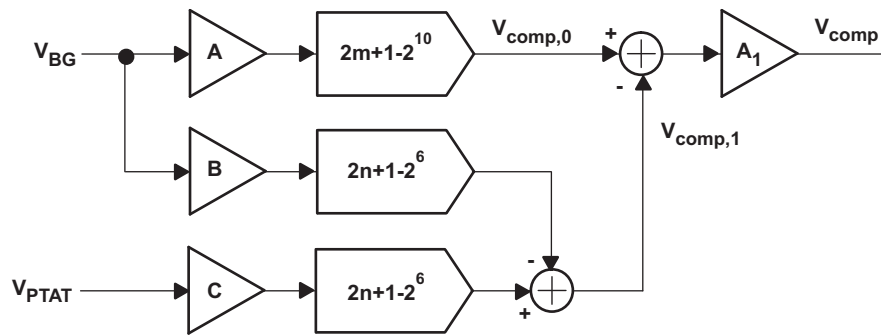

Figure 34. Block Diagram of Offset Compensation Circuit

The zero-order portion of V_{COMP} is produced by scaling V_{BG} by the gain A to generate the reference for a 10-bit DAC. The DAC scales this reference by $2m + 1 - 2^{10}$, where m is decimal equivalent of the DAC's digital input and ranges from 0 to 1023. The zero-order portion of the compensation voltage is expressed as a function of m as shown in Equation 16.

$$V_{COMP,0}(m) = V_{BG} \times A \times (2 \times m + 1 - 2^{10}) \text{ V} \quad (16)$$

The first order portion of V_{COMP} is constructed from the difference between scaled versions of V_{PTAT} and V_{BG} . The reason for this is that the temperature compensation signal should pivot about a particular reference temperature, which ideally would be the same temperature at which the zero-order portion of the sensor offset is calibrated out. Because V_{PTAT} pivots about 0 K, a temperature independent offset must be introduced to shift the pivot temperature up to a practical value like 22°C. The first-order portion of the compensation voltage is expressed in Equation 17.

$$V_{COMP,1}(n, T) = (C \times [k_{PTAT} \times (T + 273) + \xi_{PTAT}] - B \times V_{BG}) \times (2 \times n + 1 - 2^6) \text{ V} \quad (17)$$

Where the reference temperature about which this function pivots may be expressed in terms of the other variables as shown in Equation 18.

$$T_R = \frac{1}{k_{PTAT}} \cdot \left(\frac{V_{BG} \cdot B}{C} - \xi_{PTAT} \right) - 273^\circ\text{C} \quad (18)$$

The gains B and C are set to produce a reference temperature of approximately 22°C.

When Equation 17 and Equation 18 are combined and consolidate the values of the constants, the final output voltage of the offset compensation circuit is expressed as a function of m, n, T, and A_1 in the following way:

$$V_{COMP}(m, n, T, A_1) = A_1 \cdot \frac{1277}{3} \cdot [250 \cdot (2 \cdot m + 1 - 2^{10}) + 4.921 \cdot (T - 22)g(2 \cdot n + 1 - 2^6)] \text{ nV} \quad (19)$$

For resistive sensors, the gain used for the offset compensation calculation is always the same as the first stage gain in the AFE and is controlled by the same registers. For capacitive sensors, A_1 is an independent variable that may be set to meet a specific sensor or noise requirements.

NOTE

The above voltage V_{COMP} is subtracted (differentially) from the output of the first stage.

The Offset and Offset TC has two independent registers, Sensor 1 Offset Register (SEN1OFF1 and SEN1OFF2) and Sensor 2 Offset Register (SEN2OFF1 and SEN2OFF2), to accommodate for two independent sensors that can be potentially connected. The sensor offset value used is based on the SEN_CHNL bit in the Sensor Control Register (SENCTRL).

7.2.11 Stage 2 Gain Block

The Stage 2 Gain block is constructed with a low flicker noise, low offset amplifier. Both resistive bridge sensors and capacitive sensors share this gain stage. The gain setting for this stage ranges from 1 V/V to 25 V/V in 32 possible steps.

The Stage 2 Gain block has two independent registers, Sensor 1 Gain Register (SEN1GAIN) and Sensor 2 Gain Register (SEN2GAIN). This accommodates two different sensors that can be connected with different gain settings. The Stage 2 gain is determined by the SEN_CHNL bit in Sensor Control Register.

7.2.12 ADC Buffer Blocks

The device has two buffer blocks, one for the pressure signal path and one for the temperature signal path.

7.2.12.1 Analog to Digital Converter Buffer 1

The ADC Buffer 1 is a differential amplifier with 2X gain that is used to condition the pressure signal before reaching the Analog to Digital Converter (ADC).

In addition to gain this block can be configured to provide a level shift using the ADC_BUF bit in Sensor Control Register (SENCTRL). When this bit is set to 0, no offset is introduced to the signal, and the output of the ADC buffer is simply two times the output of Gain Stage 2. When this bit is set to 1, a -1.65 V offset is introduced such that the output of the ADC buffer is equal to two times the output of Gain Stage 2 minus 1.65 V. The Level Shift feature of the ADC Buffer shifts the output of the Stage 2 Gain so that the full dynamic range of the sigma-delta modulator can be used.

7.2.12.2 Analog to Digital Converter Buffer 2

The ADC Buffer 2 is a unity gain differential amplifier. This buffer block conditions the temperature signal before reaching the ADC.

7.2.13 Sigma Delta Modulator Blocks

There are two independent Sigma Delta Modulator ADCs, one for the pressure signal and another for the temperature signal.

7.2.13.1 Sigma Delta Modulator for AD Converter 1

The Sigma Delta Modulator 1 block is a 1-bit 1MHz sigma-delta modulator for the pressure sensor signal. To further condition the signal this stage is followed by two stages of digital decimation filters.

7.2.13.2 Sigma Delta Modulator for AD Converter 2

The Sigma Delta Modulator 2 block is a 1-bit 128-kHz sigma-delta modulator for the temperature signal. The input signal to the sigma-delta modulator can come from either the internal or external temperature. The output of this ADC is followed by a single decimation filter.

7.2.14 Decimation Filter Blocks

The device contains three Signal Decimation Filters. Two back to back decimation filters for the pressure sensor signal path and one decimation filter for the temperature path.

7.2.14.1 ADC1 Decimation Filter Blocks

The sensor signal path contains two decimation filters in series with each other. The first decimation filter has a fixed decimation ratio and a second decimation filter that has a variable decimation ratio.

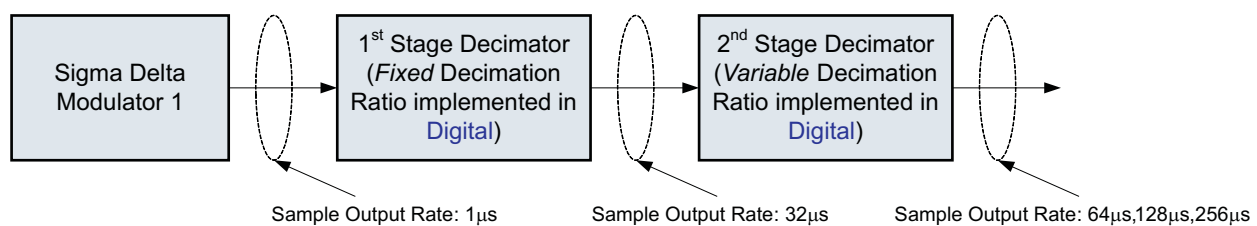

Figure 35. Decimation Filter Architecture for the Signal Channel

The first Stage Decimator Filter has a fixed decimation ratio of 32. Based on the 1-MHz sampling frequency of the sigma-delta modulator, the output rate of the 1st stage decimator is fixed at 32 µs per sample.

The second Stage Decimator has a variable decimation ratio. This filter further decimates the output of the first stage decimator. The decimation ratios of the second stage can be configured for a decimation ratio of 2, 4, or 8 using the OSR[1..0] bits in the Decimator and Low Power Control Register (DECCTRL).

The output of the second decimation filter in the sensors signal path is a 16-bit **signed** value. Some example second stage decimation output codes for given differential voltages at the input of the sigma delta modulator are shown in [Table 4](#):

Table 4. Input Voltage to Output Counts for the Signal Channel ADC

SIGMA DELTA MODULATOR DIFFERENTIAL INPUT VOLTAGE	NOISE-FREE OUTPUT
-3.3 V	-32768
-1.65 V	-16384
0	0
1.65 V	16383
3.3 V	32767

7.2.14.2 Decimation Filters for AD Converter 2

The temperature path contains one fixed ratio decimation filter block after the sigma delta modulator. The filter is 10-bit with fixed decimation ratio of 1024. Based on the 128-kHz sampling frequency, the output rate of the fixed ratio decimation filter is fixed at 8 ms per sample.

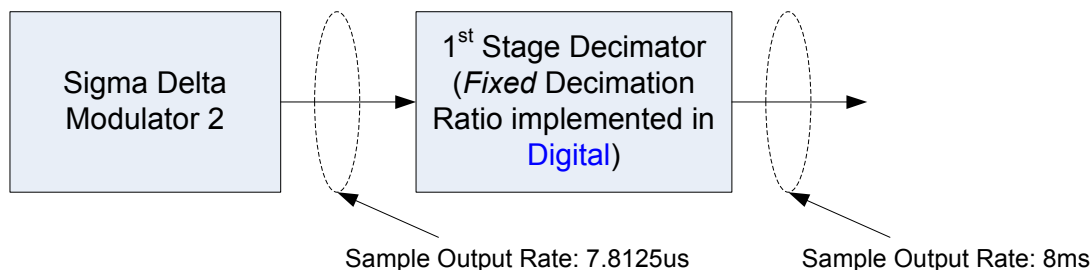

Figure 36. Decimation Filters for the Temperature Channel

The output of the temperature channel decimation filter is a 10-bit **signed** value. The equation to calculate the relationship between the input voltage at VIN3 and the output of the decimator block is shown below.

$$\text{ADC Code} = 760 \times \text{VIN3} - 820, \text{ VIN3 is voltage at the input of the buffer in volts.} \tag{20}$$

[Table 5](#) summarizes the relationship between the internal temperature sensor and the decimator output.

Table 5. Input Voltage to Output Counts for the Temperature Channel ADC

INTERNAL TEMPERATURE	NOISE-FREE OUTPUT OF TEMPERATURE CHANNEL DECIMATOR
-40°C	-196
-20°C	-140
0°C	-83
20°C	-27
40°C	28
150°C	338

7.2.14.3 Accessing the ADC Values for the 8051

the ADC Decimator Output Register (ADCMSB and ADCLSB) makes available the output of all three decimators that are available to the microprocessor.

The microprocessor specifies which decimator is loaded by writing a "1" to the appropriate bit in the Load ADC Decimator Shadow Register (LD_DEC).

If more than 1 bit in the LD_DEC register is set to 1 simultaneously, then only one decimator output is loaded into ADCMSB and ADCLSB register. The priority used to determine which decimator output gets loaded is as follows:

- Decimator 1 Output
- Decimator 2 Output
- Temperature Decimator

7.2.15 8051 Warp Microprocessor Block

The 8051 WARP microprocessor is an exceptionally high-performance version of this popular 8-bit microcontroller, requiring only 2 clocks per machine cycle rather than the 12 clocks per cycle of the industry standard device while it maintains functional compatibility with the standard device.

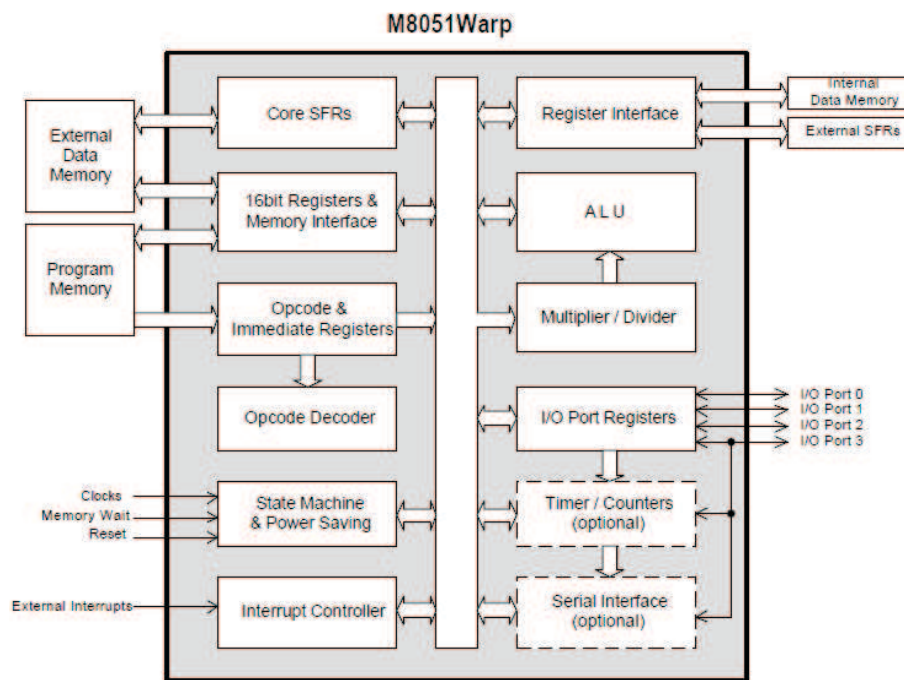

Figure 37. 8051w Core Includes Two 16-Bit Timers and Serial Interface

7.2.16 Digital Interface

The digital interfaces are used to access (read as well as write) the internal memory spaces described in [Programming and Memory](#). Each interface uses different pins for communication. The device has three separate modes of communication:

1. OWI
2. SPI
3. I²C

Each communication mode has its own protocol of communication, but all three access the same memory elements within the device. For all three communication modes the PGA400-Q1 device operates as a slave device.

Figure 38 shows the interface between the 8051W, the Memory block and the Digital Interface. In the PGA400-Q1, only the Digital Interface OR the 8051W can access the internal memory spaces. It is not possible for both 8051W and the Digital Interface to access the memory spaces simultaneously. Therefore there is an access selection bit called IF_SEL in the Micro/Interface Control Register (MICRO_IF_SEL_T) that allows either the 8051W microprocessor or the digital interfaces to have access to the OTP, EEPROM, ESFR and RAM memory spaces.

Figure 38 also shows that a special memory space called the Test Registers are only accessible only via the Digital interface. Since the Micro/Interface Control Register is in the Test Register memory block which is only accessible via the digital interface, only the digital interfaces can change the memory access selection.

To select the specific digital interface that is used for communication the DI_CTRL[1:0] bits in the Digital Interface Control Register (DI_CTRL) need to be set. If DI_CTRL is configured for I2C, then GPIO1 and GPIO3 automatically configures for I²C operation.

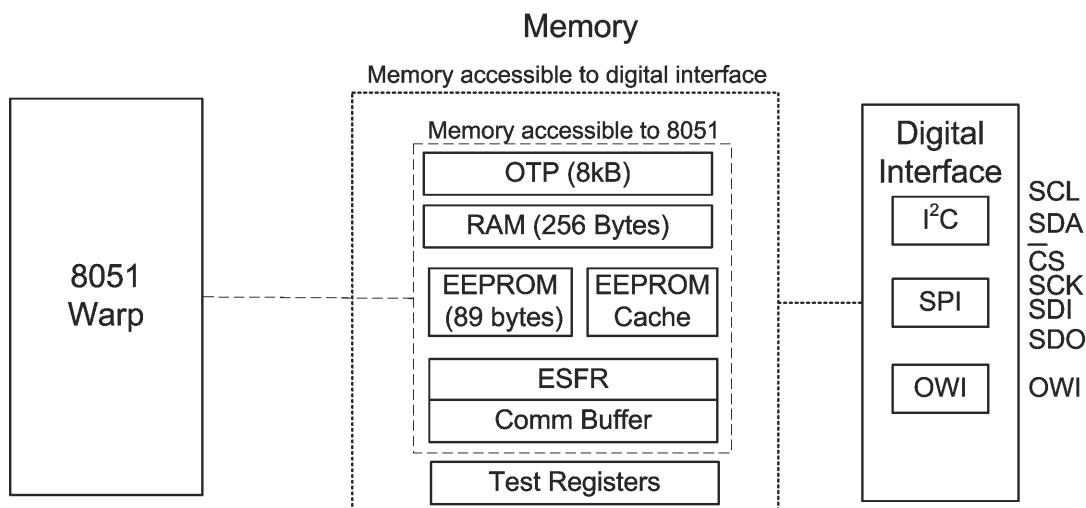

Figure 38. Digital Interface

NOTE

If Digital Interface is used to access the internal memory, the 8051W must enter reset state (to prevent the 8051W from accessing the memory). The 8051W operates in reset state using the "MICRO_RESET" bit in the Micro/Interface Control Register (MICRO_IF_SEL_T).

NOTE

The internal memory space internal is accessible via the Digital Interface without the need for the user to implement any communication software in the 8051W. The user must implement communication software, in the form of an interrupt service routine, only if the user wishes to communicate with the PGA400-Q1 while 8051W is not in reset state. This interrupt service routine is used in conjunction with a communication buffer interface, that is available in both the ESFR and Test Memory address spaces.

NOTE

While the 8051W is not in a reset state, it transfers data to the internal memory space using the Digital Interface. This transfer is accomplished using the communication buffer that exists between the Test Register memory space and the ESFR memory space (shown as COMM BUFFER in Figure 38).

7.2.17 One-Wire Interface (OWI)

The device includes an OWI digital communication interface. The main function of the OWI is to enable writes to and reads from all addresses available for OWI access. These include access to most Test Register and ESRF memory locations.

7.2.17.1 Overview of OWI

The OWI digital communication is a master-slave communication link in which the PGA400-Q1 operates as a slave device only. The master device controls when data transmission begins and ends. The slave device does not transmit data back to the master until it is commanded to do so by the master. A logic 1 (high) value on the one wire interface is defined as a *recessive* value, while a logic 0 (low) value on the one-wire interface is defined as a *dominant* value.

The VOUT1/OWI pin acts as both an analog DAC output and the interface communication pin, so that when the device is embedded inside of a system module only three pins are needed (VOUT1/OWI pin, VDD and GND). The 8051 microprocessor has the ability to control the activation and deactivation of the OWI based upon the signal driven into the VOUT1/OWI pin.

During normal operation the DAC is the last stage of the sensor signal path, and drives data out on the VOUT1/OWI pin in the form of an analog signal. To change to OWI communication mode this pin must be driven with an appropriate activation signal described in [Activating and Deactivating the OWI](#).

7.2.17.1.1 OWI Protocol

7.2.17.1.1.1 Standard Field Structure

Data is transmitted on the one-wire interface in byte sized packets. The first two bits of the OWI field will be a start bit (dominant) followed by a hold bit (recessive). The next 8 bits of the field are data bits to be processed by the OWI control logic. The final bit in the OWI field is the stop bit (recessive). The combined byte of information, and the start and stop bits make up an OWI field. A group of fields make up a transmission frame. A transmission frame is composed of the fields necessary to complete one transmission operation on the one-wire interface. The standard field structure for a one-wire field illustrated below:

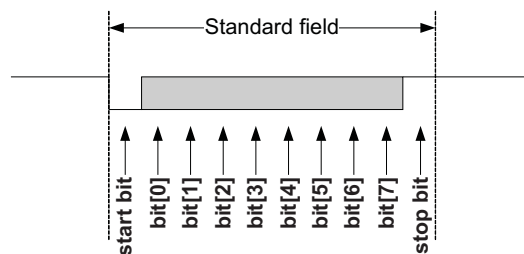

Figure 39. Standard One-Wire Field

7.2.17.1.1.2 Frame Structure

A complete one-wire data transmission operation is done in a frame with the structure given below:

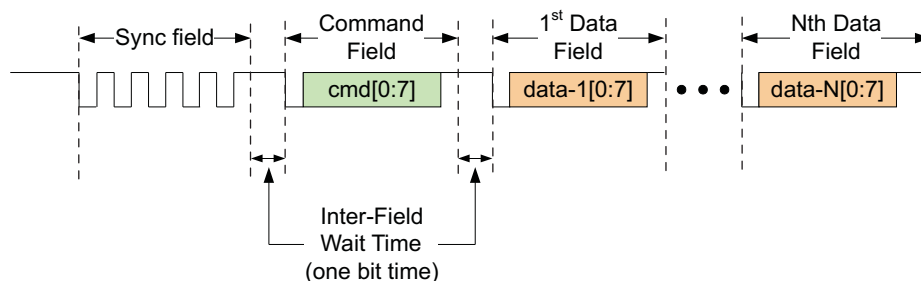

Figure 40. The One-Wire Transmission Frame

Each transmission frame must have a Synchronization field and command field followed by zero to a maximum of 8 data fields. The sync field and command fields are always transmitted by the master device. The data field(s) may be transmitted either by the master or the slave depending on the command given in the command field. It is the command field which determines direction of travel of the data fields (master-to-slave or slave-to-master). The number of data fields transmitted is also determined by the command in the command field. The inter-field wait time is optional and may be necessary for the slave or the master to process data that has been received. In most cases the terminating stop bit should provide enough processing time for either the master or the slave and the inter field wait time can be set to 0. One case where a longer Inter-field wait time may be desired is when data must change direction after the command field is sent and the slave must transmit data back to the master. Time must be allowed for the master and slave signal drivers to change direction.

If the one wire interface remains idle in either the recessive or dominant state, for more than 15 ms, then the slave communication will reset and expect to receive a sync field as the next data transmission from the master.

7.2.17.1.1.3 Sync Field

The Sync field is the first field in every frame that is transmitted by the master. The Sync field is used by the slave device to compute the bit width transmitted by the master. This bit width will be used to accurately receive all subsequent fields transmitted by the master. The bit width is defined as the number of internal oscillator clock periods that make up an entire bit of data transmitted by the master. This bit width is measured by counting the number of slave oscillator clocks in the entire length of the sync field data, and then dividing by 8. The format of the Sync field is shown below:

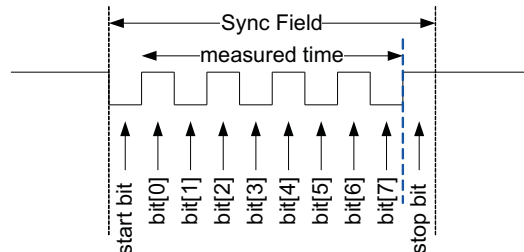

Figure 41. The OWI Sync Field

NOTE

Consecutive SYNC field bits are measured and compared to determine if a valid SYNC field is being transmitted to the PGA400 is valid. If the difference in bit widths of any two consecutive SYNC field bits is greater than +/- 25%, then PGA400 will ignore the rest of the OWI frame; i.e., the PGA400 will not respond to the OWI message.

7.2.17.1.1.4 Command Field

The command field is the second field in every frame sent by the master. The command field contains instructions about what to do with and where to send the data that is transmitted to the slave. The command field can also instruct the slave to send data back to the master during a Read operation. The number of data fields to be transmitted is also determined by the command in the command field. Depending on the type of command, additional command instructions can be sent in the subsequent data fields. The format of the command field is shown below:

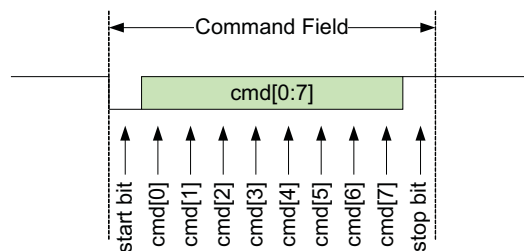

Figure 42. The One-Wire Command Field

7.2.17.1.1.5 Data Field(s)

After the Master has transmitted the command field in the transmission frame, Zero or more Data Fields are transmitted to the slave (Write operation) or to the master (Read operation). The Data fields can be raw EEPROM data or address locations in which to store data. The format of the data is determined by the command in the command field. The typical format of a data field is shown below:

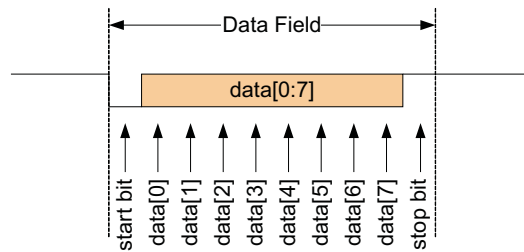

Figure 43. The One-Wire Data Field

7.2.17.1.2 OWI Operations

7.2.17.1.2.1 Write Operation

The write operation on the one-wire interface is fairly straightforward. The command field specifies the write operation, where the subsequent data bytes are to be stored in the slave, and how many data fields are going to be sent. Additional command instructions can be sent in the first few data fields if necessary. The write operation is illustrated in Figure 44.

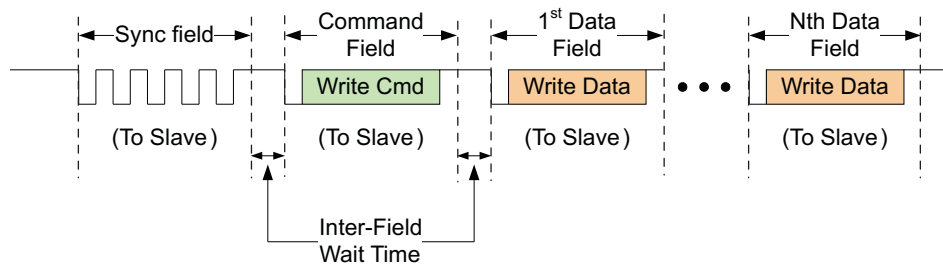

Figure 44. Write Operation

7.2.17.1.2.2 Read Operation

The read operation requires two consecutive transmission frames to move data from the slave to the master. The first frame is the Read Initialization Frame. It tells the slave to retrieve data from a particular location within the slave device and prepare to send it over the OWI. The data location may be specified in the command field or may require additional data fields for complete data location specification. The data will not be sent until the master commands it to be sent in the subsequent frame called the Read Response Frame. During the read response frame the data direction changes from master → slave to slave → master right after the read response command field is sent. Enough time exist between the command field and data field in order to allow the signal drivers time to change direction. This wait time is 20us and the timer for this wait time is located on the slave device. After this wait time is complete the slave will transmit the requested data. The master device is expected to have switched its signal drivers and is ready to receive data. The Read frames are shown in Figure 45.

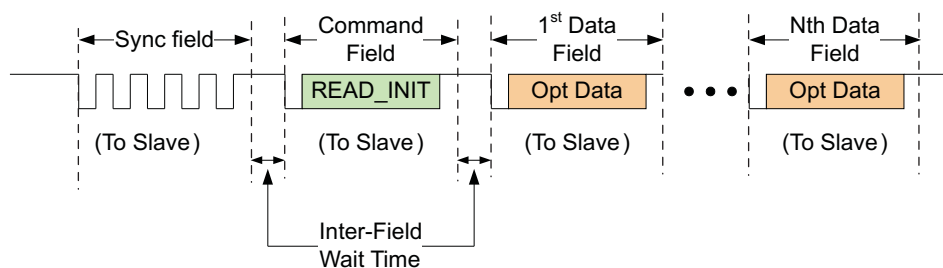

Figure 45. Read Initialization Frame

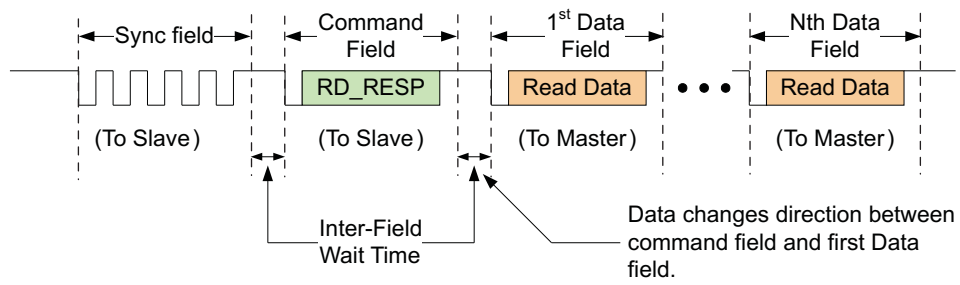

Figure 46. Read Response Frame

7.2.17.1.3 OWI Commands

The main function of the OWI will be to write to and read from all addresses available for OWI access. These include access to most Test Register and ESFR memory locations on the PGA400-Q1 device. In addition the OWI will have access to the EEPROM cache to enable customer specific EEPROM programming. As such, most OWI commands will be composed of a write or read command in the OWI command field followed by an address in the 1st data field, and possibly data to written in the second data field. Two special commands discussed below may be supported for this release of the PGA400-Q1. The P2,P1,P0 bits in the command field determine the memory page that is being accessed by the OWI.

The memory page decode is as follows:

Table 6. OWI Memory Page Decode

P2	P1	P0	Memory Page
0	0	0	Test Control Registers
0	0	1	Internal RAM
0	1	0	ESFR Registers
0	1	1	Program Memory (Hi address)
1	0	0	Program Memory (Lo Address)
1	0	1	EEPROM cache

Note that for OWI to have access to memories other than Test register space, the IF_SEL in Micro/Interface Control Test register has to be set to '1'.

7.2.17.1.3.1 OWI Write Command

Field Location	Description	Bit 7	Bit 6	Bit 5	Bit 4	Bit 3	Bit 2	Bit 1	Bit 0
Command Field	Basic Write Command	0	P2	P1	P0	0	0	0	1
Data Field 1	Destination Address	A7	A6	A5	A4	A3	A2	A1	A0
Data Field 2	Data byte to be written	D7	D6	D5	D4	D3	D2	D1	D0

7.2.17.1.3.2 OWI Read Initialization Command

Field Location	Description	Bit 7	Bit 6	Bit 5	Bit 4	Bit 3	Bit 2	Bit 1	Bit 0
Command Field	Read Init Command	0	P2	P1	P0	0	0	1	0
Data Field 1	Fetch Address	A7	A6	A5	A4	A3	A2	A1	A0

7.2.17.1.3.3 OWI Read Response Command

Field Location	Description	Bit 7	Bit 6	Bit 5	Bit 4	Bit 3	Bit 2	Bit 1	Bit 0
Command Field	Read Response Command	0	1	1	1	0	0	1	1
Data Field 1	Data Retrived (OWI drives data out)	D7	D6	D5	D4	D3	D2	D1	D0

PGA400-Q1

SLDS186A – MARCH 2012 – REVISED JULY 2016

www.ti.com
7.2.17.1.3.4 OWI Burst Write Command (EEPROM Cache Access)

Field Location	Description	Bit 7	Bit 6	Bit 5	Bit 4	Bit 3	Bit 2	Bit 1	Bit 0
Command Field	EE_CACHE Write Command Cache Bytes (0–7)	1	1	1	0	0	0	0	1
Data Field 1	1st Data Byte to be written	D7	D6	D5	D4	D3	D2	D1	D0
Data Field 2	2nd Data Byte to be written	D7	D6	D5	D4	D3	D2	D1	D0
Data Field 3	3rd Data Byte to be written	D7	D6	D5	D4	D3	D2	D1	D0
Data Field 4	4th Data Byte to be written	D7	D6	D5	D4	D3	D2	D1	D0
Data Field 5	5th Data Byte to be written	D7	D6	D5	D4	D3	D2	D1	D0
Data Field 6	6th Data Byte to be written	D7	D6	D5	D4	D3	D2	D1	D0
Data Field 7	7th Data Byte to be written	D7	D6	D5	D4	D3	D2	D1	D0
Data Field 8	8th Data Byte to be written	D7	D6	D5	D4	D3	D2	D1	D0

Field Location	Description	Bit 7	Bit 6	Bit 5	Bit 4	Bit 3	Bit 2	Bit 1	Bit 0
Command Field	EE_CACHE Write Command Cache bytes (8–15)	1	1	1	0	0	0	1	0
Data Field 1	1st Data Byte to be written	D7	D6	D5	D4	D3	D2	D1	D0
Data Field 2	2nd Data Byte to be written	D7	D6	D5	D4	D3	D2	D1	D0
Data Field 3	3rd Data Byte to be written	D7	D6	D5	D4	D3	D2	D1	D0
Data Field 4	4th Data Byte to be written	D7	D6	D5	D4	D3	D2	D1	D0
Data Field 5	5th Data Byte to be written	D7	D6	D5	D4	D3	D2	D1	D0
Data Field 6	6th Data Byte to be written	D7	D6	D5	D4	D3	D2	D1	D0
Data Field 7	7th Data Byte to be written	D7	D6	D5	D4	D3	D2	D1	D0
Data Field 8	8th Data Byte to be written	D7	D6	D5	D4	D3	D2	D1	D0

7.2.17.1.3.5 OWI Burst Read Command (EEPROM Cache Access)

Field Location	Description	Bit 7	Bit 6	Bit 5	Bit 4	Bit 3	Bit 2	Bit 1	Bit 0
Command Field	Burst read Response (8-bytes)	1	1	1	0	0	0	0	0
Data Field 1	1st Data Byte Retrieved EE Cache Byte 0	D7	D6	D5	D4	D3	D2	D1	D0
Data Field 2	2nd Data Byte Retrieved EE Cache Byte 1	D7	D6	D5	D4	D3	D2	D1	D0
Data Field 3	3rd Data Byte Retrieved EE Cache Byte 2	D7	D6	D5	D4	D3	D2	D1	D0
Data Field 4	4th Data Byte Retrieved EE Cache Byte 3	D7	D6	D5	D4	D3	D2	D1	D0
Data Field 5	5th Data Byte Retrieved EE Cache Byte 4	D7	D6	D5	D4	D3	D2	D1	D0
Data Field 6	6th Data Byte Retrieved EE Cache Byte 5	D7	D6	D5	D4	D3	D2	D1	D0
Data Field 7	7th Data Byte Retrieved EE Cache Byte 6	D7	D6	D5	D4	D3	D2	D1	D0
Data Field 8	8th Data Byte Retrieved EE Cache Byte 7	D7	D6	D5	D4	D3	D2	D1	D0

Field Location	Description	Bit 7	Bit 6	Bit 5	Bit 4	Bit 3	Bit 2	Bit 1	Bit 0
Command Field	Burst read Response (8-bytes)	1	1	1	0	0	0	1	1
Data Field 1	1st Data Byte Retrieved EE Cache Byte 8	D7	D6	D5	D4	D3	D2	D1	D0
Data Field 2	2nd Data Byte Retrieved EE Cache Byte 9	D7	D6	D5	D4	D3	D2	D1	D0
Data Field 3	3rd Data Byte Retrieved EE Cache Byte 10	D7	D6	D5	D4	D3	D2	D1	D0
Data Field 4	4th Data Byte Retrieved EE Cache Byte 11	D7	D6	D5	D4	D3	D2	D1	D0
Data Field 5	5th Data Byte Retrieved EE Cache Byte 12	D7	D6	D5	D4	D3	D2	D1	D0
Data Field 6	6th Data Byte Retrieved EE Cache Byte 13	D7	D6	D5	D4	D3	D2	D1	D0
Data Field 7	7th Data Byte Retrieved EE Cache Byte 14	D7	D6	D5	D4	D3	D2	D1	D0
Data Field 8	8th Data Byte Retrieved EE Cache Byte 15	D7	D6	D5	D4	D3	D2	D1	D0

7.2.17.1.4 OWI Communication Error Status

detects errors in OWI communication. OWI_ERR_1 and OWI_ERR_2 Test registers contain OWI communication error bits. The communication errors detected include

The PGA400-Q1 detects and report errors in OWI communication. The [OWI Error Status 1 \(OWI_ERR_1\)](#) and [OWI Error Status 2 \(OWI_ERR_2\)](#) contain the error bits. The communication errors reported with the registers include:

- Out of range communication baud rate
- Invalid SYNC field
- Invalid STOP bits in command and data
- Invalid OWI command

7.2.17.2 Activating and Deactivating the OWI

7.2.17.2.1 Activating OWI Communication

If the device is operating in the normal operation where the DAC is active and I2C or SPI communication modes are not enabled the following activation signal can be driven into the VOUT1/OWI pin to place it into OWI communication mode. The process begins with driving the OWI_EN voltage on the VOUT1/OWI pin. As soon as the DAC voltage exceeds 5.4 volts the DAC is switched off by a comparator. Once the pin voltage reaches the OWI_EN voltage threshold a deglitch timer begins. Once the pin voltage has been asserted for a time greater than the deglitch time the OWI Activation Comparator transmits a logic 1 value to the OWI Controller.

In order to describe the OWI activation signal, Figure 48 will be used as a reference.

This deglitch time is set by the OWI_DEGLITCH_SEL bit in the Digital Interface Control Register (DI_CTRL), and has the following properties:

- OWI_DEGLITCH_SEL = 0 → OWI Activation deglitch time = 1 ms
- OWI_DEGLITCH_SEL = 1 → OWI Activation deglitch time = 10 ms
- The default value for OWI_DEGLITCH_SEL bit is 0, which corresponds to deglitch time of 1 ms.

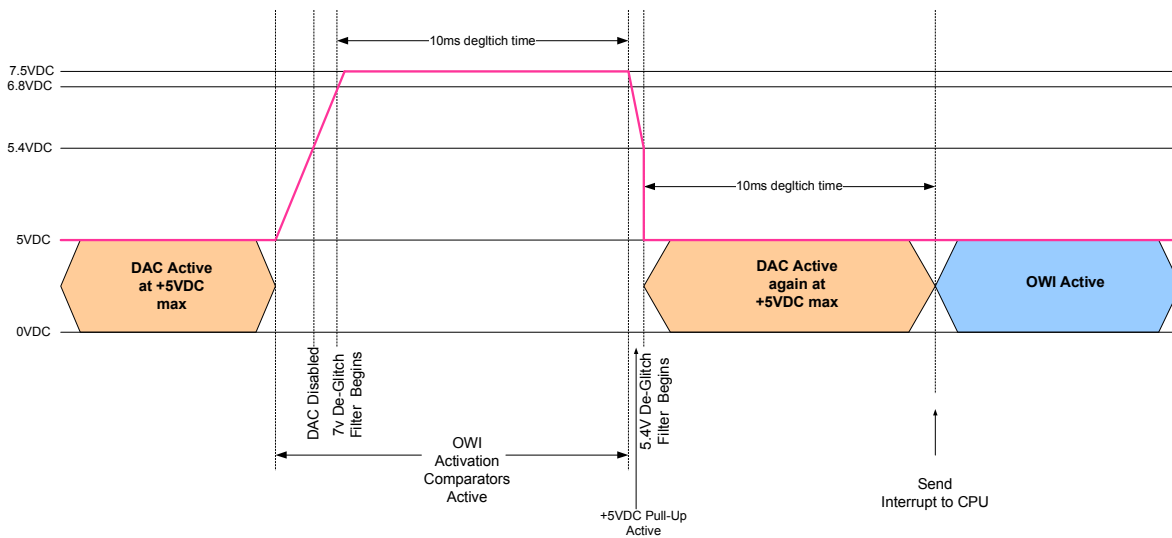

Figure 47. OWI Activation Using Overvoltage Drive, Deglitch is Assumed to be 10 ms

When the high voltage has been maintained for the proper deglitch time, the pin must then be driven back to the standard 5V IO voltage for an additional deglitch time set by the same bit as before. During this second deglitch time the DAC becomes active again only until the the second deglitch time has passed. Once this second deglitch period is over the OWI controller generates an OWI activation interrupt that is sent to the 8051. This user interrupt service routine switches the VOUT1/OWI pin's mode by writing to the appropriate registers. The OWI transceiver is switched to the VOUT1/OWI pin and the DAC is placed back into the OFF state. The capability to drive the appropriate OWI_EN voltage must be provided in the test environment.

The XCVR switch, controlled by an ESFR register, changes the output drive from the unidirectional DAC analog signal to the bi-directional OWI digital signal interface. Once this switch is selecting the OWI transceiver, OWI data can be transmitted and received through the VOUT1/OWI pin. The OWI transceiver is responsible for translating voltage levels to appropriate logic levels so that the OWI controller may process the OWI data. The OWI_REQ deglitch filter ensures that no invalid activation signals are transmitted from the analog OWI Activation Comparator to the 8051 interrupt input. Both the DAC switch ESFR and the XCVR switch ESFR must be set via the OWI interrupt service routine. It is recommended to set the DAC switch to the OFF position before setting the XCVR switch to the OWI mode.

If the device is already in SPI communication mode or I²C communication mode, enabling OWI communication changing the DAC enable bit and the OWI transceiver enable bit in the Digital Interface Control Register (DI_CTRL) is the only requirement. The register bits can be set manually in the following order.

1. The register bits DI_CTRL[1:0] in the Digital Interface Control Register (DI_CTRL) need to be set to 0b10.

This activates the OWI controller and deactivates the DAC via the DAC switch.

- The OWI_XCR_EN bit in the Digital Interface Control Register (DI_CTRL) must be set to 1. This turns on the OWI transceiver and switches the VOUT1/OWI pin to the OWI transceiver.

NOTE

Note that DI_CTRL[1:0] and OWI_XCR_EN bits can be written simultaneously (in 1 write command). However, because the state of the VOUT1/OWI is unknown during the transition from VOUT1 to OWI, it is recommended that the master wait at least 15 ms before transmitting the OWI command.

Figure 48 shows a functional equivalent circuit for the structure of the OWI and DAC circuitry.

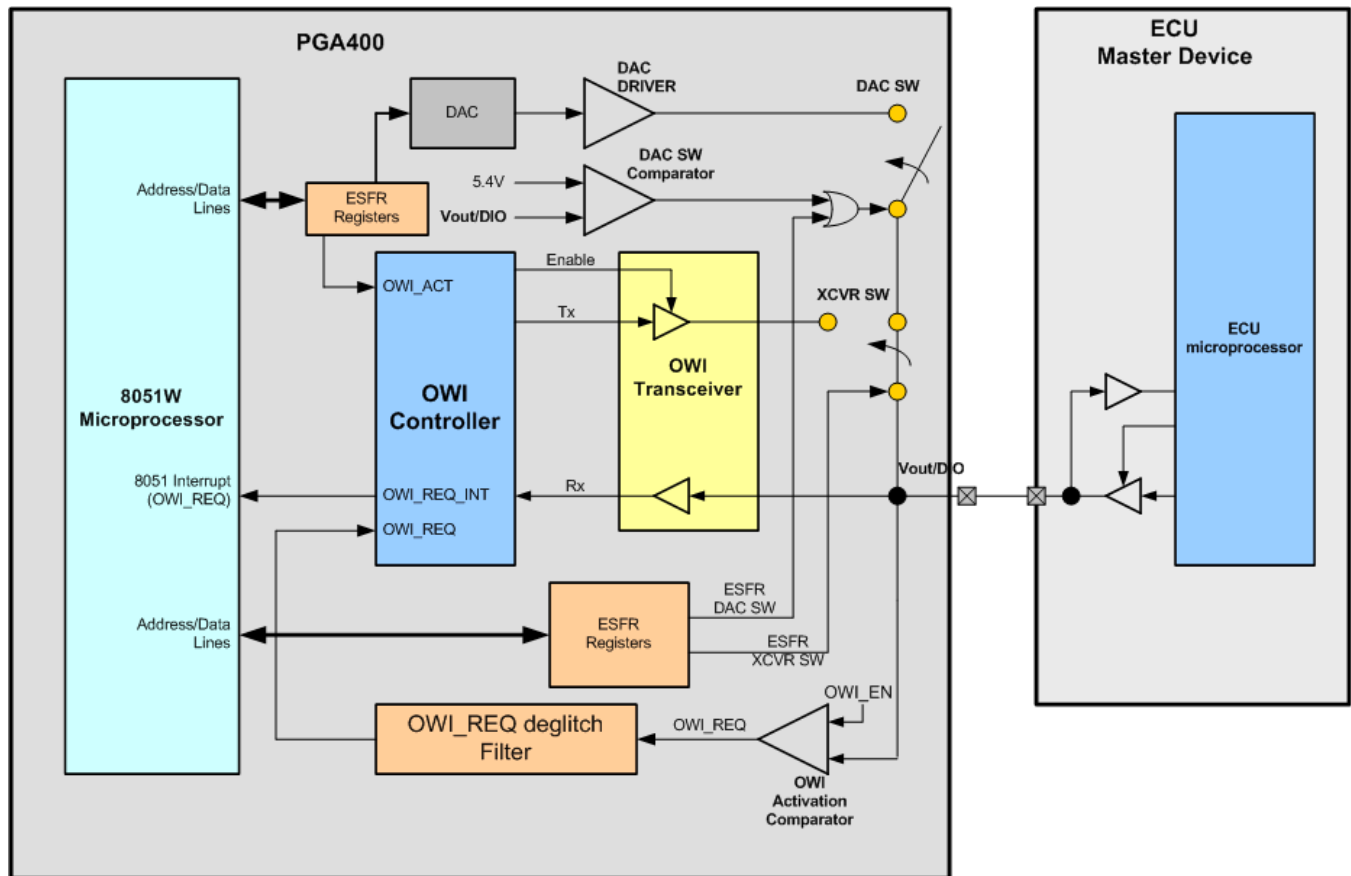

Figure 48. OWI System Components

7.2.17.2.2 Deactivating OWI Communication

In order to deactivate the OWI communication the following two steps must be performed in any order.

- The OWI_XCR_EN bit in the Digital Interface Control Register (DI_CTRL) must be set to 0. This turns off the OWI transceiver and switch the VOUT1/OWI pin to the DAC driver.
- The register bits DI_CTRL[1:0] in the Digital Interface Control Register (DI_CTRL) must be a value other than 0b10. This selects a different Digital Interface (either I²C or SPI) and it also switches on the DAC driver.

7.2.18 SPI

The device includes a SPI digital communication interface. The main function of the SPI is to enable writes to and reads from all addresses available for SPI access.

7.2.18.1 Overview of SPI

SPI is a synchronous, serial, master-slave, communication standard that requires the following four pins:

- SDI: SPI slave in master out, serial input pin
- SDO: SPI slave out master in, serial output pin (tri-state output)
- SCK: SPI clock which controls the communication
- $\overline{\text{CS}}$: chip select (active low)

SPI communicates in a master/slave style where only one device, the master, can initiate data transmissions. The PGA400-Q1 always acts as the slave in SPI communication, where whatever external device that is communicating to it becomes the master mode. Both devices begin data transmission with the most significant bit (MSB) first.

Because multiple slave devices can exist on one bus, the master node is able to notify the specific slave node that it is ready to begin communicating with by driving the $\overline{\text{CS}}$ pin to a low logic level. In the absence of active transmission, the master SPI device places the device in reset by driving the $\overline{\text{CS}}$ pin to a high logic level. During a reset state the SDO pin operates in tri-state mode. For the SPI to have access to memory locations other than test register space, the IF_SEL bit in the Micro/Interface Control Test register (MICRO_IF_SEL_T) has to be set to 1.

7.2.18.2 SPI Interface Protocol

7.2.18.2.1 SPI Master to PGA400 Commands

The Serial Peripheral Interface (SPI) is a 24-bit protocol with a 3-bit memory access control word, a read-write bit, an 8-bit address and an 8-bit data word. The command codes are described in [Table 7](#).

Table 7. SPI Command Codes

Bit	Function	Description
23:21	Memory access control	
	TEST = 3'b000	Access to Test Registers
	IRAM = 3'b001	Access to Internal RAM
	ESFR = 3'b010	Access to ESFR
	OTP_ADDRHI = 3'b011	Determines the 5 MSBs of the OTP address
	OTP = 3'b100	The SPI will read from or write to the OTP location specified by the OTP address. The OTP address is specified by the address in the OTP_ADDRHI location and the address in this transfer
	EECACHE = 3'b101	Access to the EEPROM cache. The specific EEPROM Bank has to be selected via "EEPROM Access Control" TEST registers
20:13	Data Address	
12	Write if 1, Read if 0	
11:4	Data	
3:0	Don't Care	

7.2.18.2.2 PGA400-Q1 to SPI Master Response

For SPI transfers to all the memories, the read data is available on the next SPI transfer as shown in [Figure 49](#). That is, when reading from a memory location, the user has to send a subsequent transfer to get the data back.

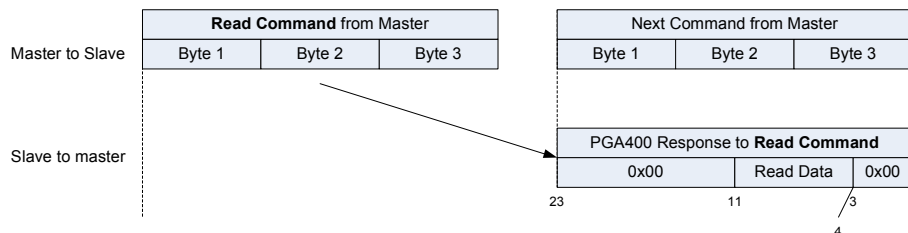

Figure 49. Response to SPI Read Commands is Available When the Next Command is Sent

The SPI response is described in Table 8. Note that only 1 byte of data can be read with one SPI read command.

Table 8. SPI Response

Bit	Function
23:12	Zeros
11:4	Read Data
3:0	Zeros

7.2.18.2.3 SPI Command Examples

Table 9 lists a few examples of SPI Transfers.

Table 9. SPI Transfers Examples

Command	Master to Slave Data on SPI MOSI
Read Test register 0x04 (Comm Buffer)	000 0000 0100 0 XXXX XXXX 0000
Write 0x80 to ESFR 0xB9 (DAC1 LSB)	010 1011 1001 1 1000 0000 0000
Write 0x34 to IRAM 0x7F	001 0111 1111 1 0011 0100 0000
Read from EEPROM Bank 4, Byte 2	Write to Test Register 0x00D to select Bank4. 000 0000 1011 1 0000 0100 0000 Then send the following command to read data: 101 0100 0010 0 XXXX XXXX 0000
Write 0xD9 to OTP 0x1765	Select High Address of OTP: 011 XXXX XXXX 1 0001 0111 0000 Select Low Address and Send Data: 100 0110 0101 1 1101 1001 0000

7.2.18.3 Clocking Details

SPI input data (input to MOSI pin) must be valid on the rising edge of the SCK clock. SPI output data (output from MISO pin) changes on the rising edge of the SCK clock.

The SPI timing diagram is shown in Figure 2.

7.2.19 I²C Interface

The device includes an I²C digital communication interface. The main function of the I²C is to enable writes to, and reads from, all addresses available for I²C access.

7.2.19.1 Overview of I²C Interface

I²C is a synchronous serial communication standard that requires the following two pins for communication:

- GPIO_1/IC_1/SDA: I²C Serial Data Line (SDA)
- GPIO_3/OC_1/SCL: I²C Serial Clock Line (SCL)

I²C communicates in a master/slave style communication bus where one device, the master, can initiate data transmission. The device always acts as the slave device in I²C communication, where the external device that is communicating to it acts as the master node. The master device is responsible for initiating communication over the SDA line and supplying the clock signal on the SCL line. When the I²C SDA line is pulled low it is considered a logical zero, and when the I²C SDA line is floating high it is considered a logical one. For the I²C interface to have access to memory locations other than test register space, the IF_SEL bit in the Micro/Interface Control Test register (MICRO_IF_SEL_T) has to be set to logic one.

7.2.19.2 I²C Interface Protocol

The basic Protocol of the I²C frame for a Write operation is shown in [Figure 50](#):

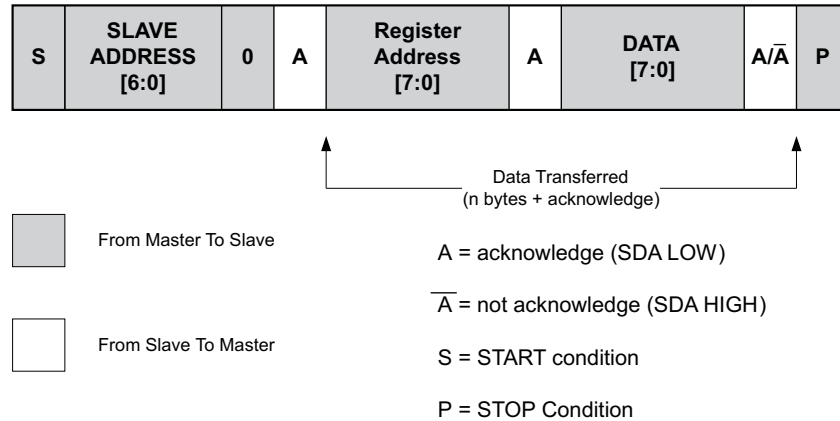

Figure 50. I²C Write Operation: A Master-Transmitter Addressing a PGA400-Q1 Slave With a 7-Bit Slave Address

The diagram represents the data fed into or out from the I²C SDA port.

The basic data transfer is to send 2 bytes of data to the specified Slave Address. The first datafield is the register address and the second datafield is the data sent or received.

The I²C Slave Address is used to determine which memory page is being referenced. [Table 10](#) shows the mapping of the slave address to the memory page.

Table 10. Slave Addresses

Slave Address	PGA400-Q1 Memory Page
0100000	Test Registers
0100001	Internal RAM
0100010	ESFRs
0100011	Program Memory (OTP) HI Address
0100100	Program Memory (OTP) LO Address
0100101	EEPROM cache
0100110	Reserved

The basic PGA400-Q1 I2C Protocol for a read operation is shown in [Figure 51](#).

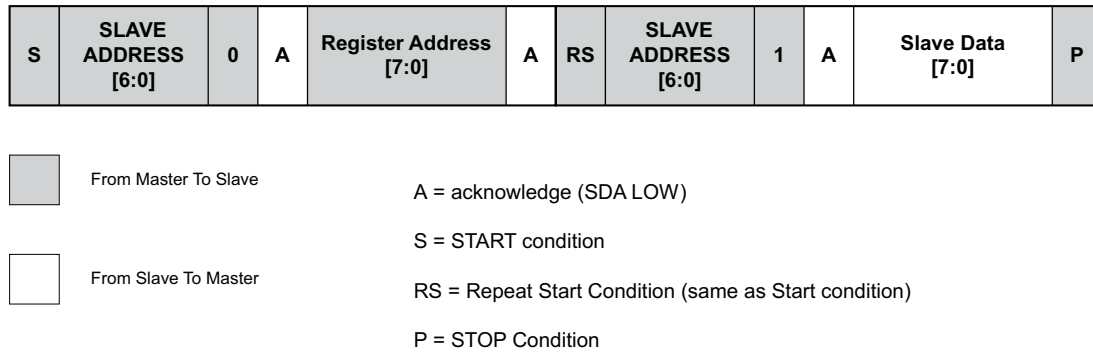

Figure 51. I2C Read Operation: A Master-Transmitter Addressing a PGA400-Q1 Slave With a 7-Bit Slave Address

For the initial Slave Address, the memory page bits are ignored. The R/W bit is set to 0.

The Register Address specifies the 8-bit address of the requested data.

The Repeat Start Condition replaces the write data from the above write operation description. This informs the PGA400-Q1 devices that Read operation will take place instead of a write operation.

The second Slave Address contains the memory page from which the data will be retrieved. The R/W bit is set to 1.

Slave data is transmitted after the acknowledge is received by the master.

To terminate the Read operation, the master forces a Stop Condition instead of allowing the PGA400-Q1 to send an acknowledge signal.

Table 11 lists a few examples of I2C Transfers.

Table 11. I2C Transfers Examples

Command	Master to Slave Data on I2C SDA
Read Test register 0x04 (Comm Buffer)	Slave Address: 0100000 Register Address: 00000100
Write 0x80 to ESFR 0xB9 (DAC1 LSB)	Slave Address: 0100010 Register Address 10111001 Data: 10000000
Write 0x34 to IRAM 0x7F	Slave Address: 0100001 Register Address 01111111 Data: 00110100
Read from EEPROM Bank 4, Byte 2	Write to Test Register 0x00D to select Bank4. Slave Address: 0100000 Register Address 00001011 Data: 00000100 Then send the following command to read data: Slave Address: 0100101 Register Address 00000010 Data: XXXX XXXX
Write 0xD9 to OTP 0x1765	Select High Address of OTP: Slave Address: 0100011 Register Address XXXXXXXX Data: 00010111 Select Low Address and Send Data: Slave Address: 0100100 Register Address 01100101 Data: 10111001

7.2.19.3 Activating the I²C Interface

To activate I²C communication the following steps must be made in order:

1. Place the 8051W into a reset state by setting the MICRO_RESET bit in the Micro/Interface Control Register (MICRO_IF_SEL_T) to logic high
2. Give control of the memory to digital interface by setting the IF_SEL bit in the Micro/Interface Control Register (MICRO_IF_SEL_T) to logic high
3. Set the DI_CTRL bits in the Digital Interface Control Register (DI_CTRL) to 0b01 for I²C interface

7.2.19.4 Clocking Details of I²C Interface

The device samples the data on the SDA line when the rising edge of the SCL line is high, and is changed when the SCL line is low. The only exceptions to this indication a start, stop or repeated start condition as shown in [Figure 52](#)

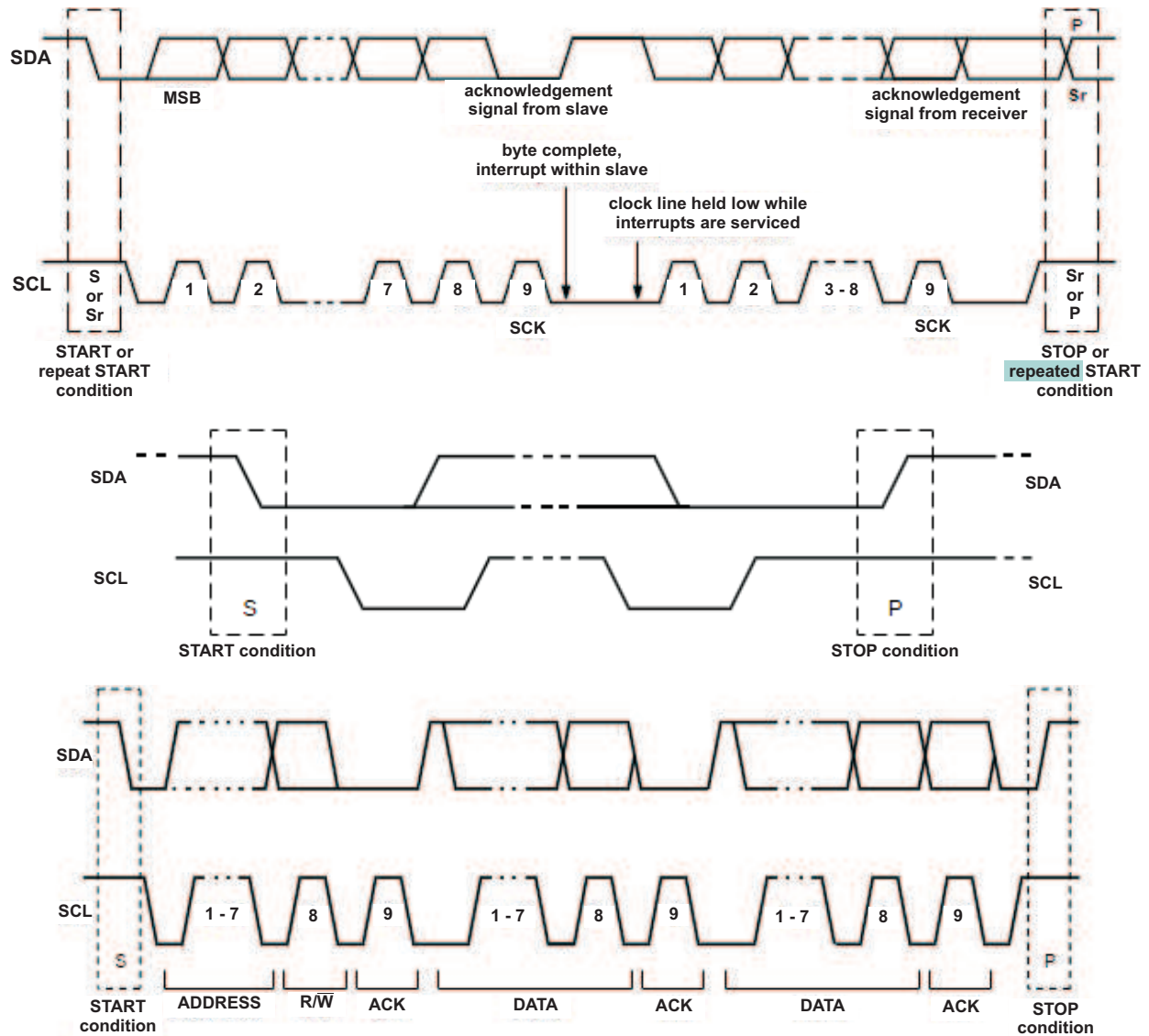

Figure 52. I²C Clocking Details

7.3 Programming and Memory

7.3.1 OTP Memory

The OTP Memory space is 8KB and is located at memory pages 3 and 4. This memory space contains program instructions for the 8051W microprocessor.

NOTE

To program the OTP memory an external VP_OTP voltage needs to be applied to the VP_OTP pin. For more information about the voltage applied on the VP_OTP pin during OTP memory programming please refer to the [Recommended Operating Conditions](#) section in this document.

7.3.2 EEPROM Memory

Figure 53 shows the EEPROM bank structure. EEPROM cells within a bank are activated only when reading from or writing to their specific EEPROM bank. Therefore the contents of each EEPROM must be transferred to the EEPROM cache before reads and writes can occur to that bank. There are a total of six banks of EEPROM, and they are located at memory page 5.

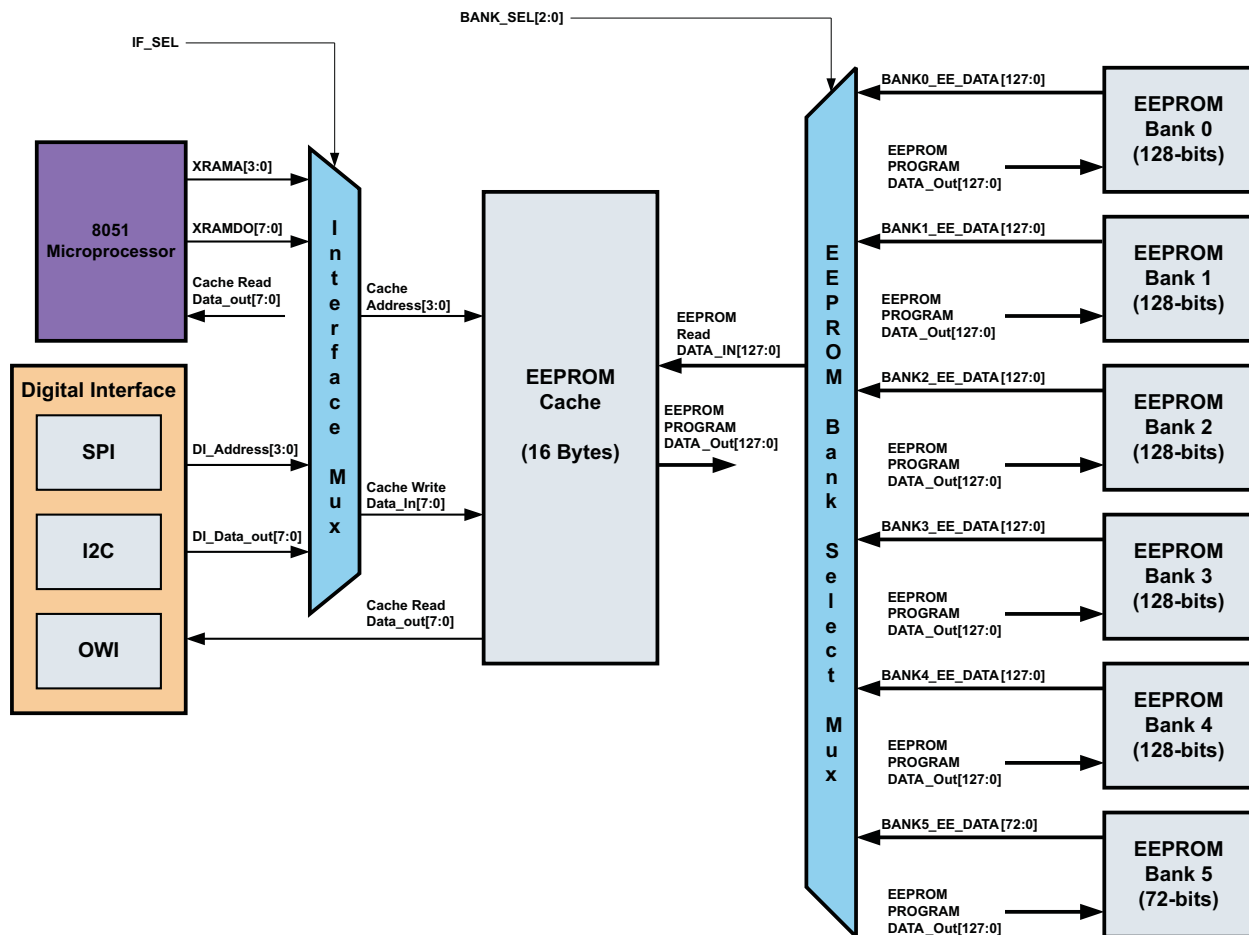

Figure 53. Structure of EEPROM Interface

Programming and Memory (continued)

7.3.2.1 EEPROM Memory Organization

7.3.2.1.1 EEPROM Cache

The EEPROM cache serves as temporary storage of data being transferred to/from a selected EEPROM bank. Data transferred to the EEPROM cache from either a digital interface or from the M8051 is byte addressable and one byte at a time can be written or read to/from the EEPROM cache, the exception being a special OWI burst write/read access in which 8 bytes of data can be written/read at a time. Selection of the EEPROM cache interface is determined by the IF_SEL bit in the EEPROM Access Control register.

Data transferred to the cache from an EEPROM bank is loaded 128-bits at a time during the EEPROM cache load cycle. EEPROM Bank selection is determined by the value placed in the BANK_SEL bits in the EEPROM Access Control Register.

When programming an EEPROM bank, the EEPROM cache holds the programming data for the amount of time necessary to complete the EEPROM programming process.

7.3.2.1.2 Bank 0

Bank 0 is used for storage of customer data and is the only bank which can be programmed by both the M8051 and the Digital Interface. 16 bytes of EEPROM data are provided in bank 0. No CRC validation against a pre-stored CRC value occurs when Bank 0 is programmed, and thus, there are no dedicated EEPROM Cells used for CRC storage.

Due to limited number of erase/write cycles, the user has to keep track of the number of writes to the EEPROM Bank 0 in the field. This number has to be stored in EEPROM Bank 0 because only EEPROM Bank 0 can be updated in the field.

7.3.2.1.3 Banks 1-4

Banks 1–4 are used for storage of customer data. Each bank 1 through 4 provides 128-bits of data storage for a total of 512 bits (64 bytes) of storage data. Only a digital interface can program these EEPROM banks. Each time one of these banks is programmed a CRC is calculated based upon the data held in the EEPROM cache during program. This calculated CRC value is stored internally and validated after bank programming is complete. A separate CRC value is stored internally in the PGA400-Q1 device for each bank 1 through 4 upon completion of a bank program.

7.3.2.1.4 Bank 5

Bank 5 is provided to the customer for calibration value storage, but it is not specifically required to use this EEPROM bank for this purpose. 64-bits (8 bytes) of data storage are provided for calibration data or for general data storage. Only the first 9 bytes of the EEPROM cache are used to program Bank 5. When programming Bank 5 it is required to place the cumulative CRC value for banks 1–5 in the EEPROM cache Address 0x558. This CRC value is calculated over all data in banks 1 through 4 and the first 64-bits of data in bank 5. Once programming of Bank 5 is complete, this CRC value is validated.

Programming and Memory (continued)

7.3.2.1.5 EEPROM Control and Status Registers (ESFR and Test)

Two versions of EEPROM Control Registers are available in the PGA400-Q1 device. One is used by the 8051W, the other is used by the digital interface.

See [ESFR](#) and [Test Registers](#) for a description of these registers.

7.3.2.1.5.1 Digital Interface EEPROM Control Register

For the digital interface, the EEPROM Access Control Register is used to initiate EEPROM programming, force an EEPROM cache reload and select the current EEPROM bank to access. These functions are available using test register address 0x00D:

7.3.2.1.5.2 8051W EEPROM Program Register (Used with Bank 0 only)

The 8051W can only program Bank 0, and its control of the EEPROM programming process is limited to simply initiating the program process. The programming process is initiated by writing to ESFR address 0x2E2, (8051W ESFR address 0xE2). This bit is only active if the M8051 is selecting Bank 0 at the time that this bit is set to 1.

7.3.2.1.5.3 Microprocessor Reset/Interface Control Register

The Interface control register is used to select between M8051 control of the EEPROM cache or digital interface control of the EEPROM cache.

7.3.2.1.5.4 EEPROM Status Register

Status bits for EEPROM Access and programming are stored in both the test register address space and the ESFR address space. The M8051 cannot access the test register address space and a digital interface can only access the ESFR address space when the IF_SEL signal = 1, thus, the EEPROM status register contents is available in both address spaces.

7.3.2.1.6 Accessing data from EEPROM Banks

All data read from EEPROM Banks 0 through 5 must go through the EEPROM cache. Loading data from an EEPROM bank to the EEPROM cache is done by selecting the EEPROM bank whose data needs to be read. It will take 8 μ s for the data transfer to complete. Upon power-up, the PGA400-Q1 device will initially load the Bank 0 contents into the EEPROM cache. Once EEPROM Bank data is in the cache, it is byte addressable via the digital interface or via the M8051 and can be read one byte at a time. A special burst read mode is available for the OWI digital interface.

Programming and Memory (continued)

7.3.2.1.6.1 EEPROM Cache Load Process

EEPROM Bank Select with a Digital Interface

When the digital interface is accessing the EEPROM cache (i.e. IF_SEL = 1), EEPROM Bank selection is performed by setting the bank select bits in the EEPROM control register, in the test register address space. The initial bank select values are “EEPROM Bank Select” = ‘000’. Writing a new value to these 3 bits causes the EEPROM load process to begin.

EEPROM Bank Select with the 8051W

When the M8051 is accessing the EEPROM cache (i.e. IF_SEL = 0), EEPROM Bank selection is performed using the external memory address bits XRAMA[6:4]. The EEPROM cache is linked directly to the external memory interface of the M8051. Any time a write or read request is made, the digital logic will determine access the appropriate EEPROM bank automatically.

EEPROM Cache Addresses

Addressing the EEPROM cache is slightly different for the digital interfaces than for the M8051. The digital interfaces must supply a memory page address as part of its total address value. The memory page address of the EEPROM cache is 0x5. Since the M8051 is directly connected to the EEPROM cache through its External Memory interface, no memory page address is required.

EEPROM Cache Address Map for 8051W

The 8051W external memory interface is connected directly to the EEPROM cache when IF_SEL = 0. The External Memory Address port XRAMA[7:0] is mapped as follows:

XRAMA[7] : not used
 XRAMA[6:4] : EEPROM Bank Select
 XRAMA[3:0] : EEPROM cache Address

Since the XRAMA address contains the bank select values, every time this value differs from the current stored bank select value, the EPROM cache load process will begin. If the M8051 issues a write command to its external memory interface and simultaneously changes the bank select bits, (XRAMA[6:4]) then the write operation will the latched and held off until the EEPROM cache load operation is complete.

Table 12. M8051 External Memory Interface Address Map to the EEPROM Cache

Address range of XRAMA[7:0] (hex)	EEPROM Data Accessed
00 → 0F	EEPROM Bank 0 Selected, Address cache Bytes 0 through 15
10 → 1F	EEPROM Bank 1 Selected, Address cache Bytes 0 through 15
20 → 2F	EEPROM Bank 2 Selected, Address cache Bytes 0 through 15
30 → 3F	EEPROM Bank 3 Selected, Address cache Bytes 0 through 15
40 → 4F	EEPROM Bank 4 Selected, Address cache Bytes 0 through 15
50 → 5F ⁽¹⁾	EEPROM Bank 5 Selected, Address cache Bytes 0 through 15

(1) Bank 5 only has 72 EEPROM cells. The entire EEPROM cache can be filled with data when Bank 5 is selected but only the first 9 bytes can be programmed.

Table 13. EEPROM Cache Address Map for the M8051

XRAMA[3:0] (hex)	EEPROM Cache Byte	EEPROM Cells mapped to Cache
0	EEPROM Cache Byte 0 [7:0]	EEPROM Bank Cells [7:0]
1	EEPROM Cache Byte 1 [7:0]	EEPROM Bank Cells [15:8]

Table 13. EEPROM Cache Address Map for the M8051 (continued)

XRAMA[3:0] (hex)	EEPROM Cache Byte	EEPROM Cells mapped to Cache
2	EEPROM Cache Byte 2 [7:0]	EEPROM Bank Cells [23:16]
3	EEPROM Cache Byte 3 [7:0]	EEPROM Bank Cells [31:24]
4	EEPROM Cache Byte 4 [7:0]	EEPROM Bank Cells [39:32]
5	EEPROM Cache Byte 5 [7:0]	EEPROM Bank Cells [47:40]
6	EEPROM Cache Byte 6 [7:0]	EEPROM Bank Cells [55:48]
7	EEPROM Cache Byte 7 [7:0]	EEPROM Bank Cells [63:56]
8	EEPROM Cache Byte 8 [7:0]	EEPROM Bank Cells [71:64]
9	EEPROM Cache Byte 9 [7:0]	EEPROM Bank Cells [79:72]
A	EEPROM Cache Byte 10 [7:0]	EEPROM Bank Cells [87:80]
B	EEPROM Cache Byte 11 [7:0]	EEPROM Bank Cells [95:88]
C	EEPROM Cache Byte 12 [7:0]	EEPROM Bank Cells [103:96]
D	EEPROM Cache Byte 13 [7:0]	EEPROM Bank Cells [111:104]
E	EEPROM Cache Byte 14 [7:0]	EEPROM Bank Cells [119:112]
F	EEPROM Cache Byte 15 [7:0]	EEPROM Bank Cells [127:120]

EEPROM Cache address map for Digital Interfaces

Since the Digital interface requires a memory page value, 11-bits are used to describe the memory address locations of the PGA400-Q1 for the digital interfaces. For the EEPROM Cache the valid memory address range is from 0x500 to 0x5FF. The 3 most significant bits of the 11-bit address contain the memory page address. The memory page address for the EEPROM Cache is 0x5. The address bits 7:4 are ignored. The address bits 3:0 determine which byte in the 16 byte EEPROM Cache is accessed.

When data is transferred from the EEPROM cells to the EEPROM Cache, each of the 128 EEPROM cells is mapped to a specific bit location in the EEPROM Cache. The address location and EEPROM Cell mapping is shown below:

Table 14. EEPROM Cache Address Map for the Digital Interface

Digital Interface Address (hex) ⁽¹⁾	EEPROM Cache Byte	EEPROM Cells mapped to Cache
5x0	EEPROM Cache Byte 0 [7:0]	EEPROM Bank Cells [7:0]
5x1	EEPROM Cache Byte 1 [7:0]	EEPROM Bank Cells [15:8]
5x2	EEPROM Cache Byte 2 [7:0]	EEPROM Bank Cells [23:16]
5x3	EEPROM Cache Byte 3 [7:0]	EEPROM Bank Cells [31:24]
5x4	EEPROM Cache Byte 4 [7:0]	EEPROM Bank Cells [39:32]
5x5	EEPROM Cache Byte 5 [7:0]	EEPROM Bank Cells [47:40]
5x6	EEPROM Cache Byte 6 [7:0]	EEPROM Bank Cells [55:48]
5x7	EEPROM Cache Byte 7 [7:0]	EEPROM Bank Cells [63:56]
5x8	EEPROM Cache Byte 8 [7:0]	EEPROM Bank Cells [71:64]
5x9	EEPROM Cache Byte 9 [7:0]	EEPROM Bank Cells [79:72]
5xA	EEPROM Cache Byte 10 [7:0]	EEPROM Bank Cells [87:80]
5xB	EEPROM Cache Byte 11 [7:0]	EEPROM Bank Cells [95:88]
5xC	EEPROM Cache Byte 12 [7:0]	EEPROM Bank Cells [103:96]
5xD	EEPROM Cache Byte 13 [7:0]	EEPROM Bank Cells [111:104]
5xE	EEPROM Cache Byte 14 [7:0]	EEPROM Bank Cells [119:112]
5xF	EEPROM Cache Byte 15 [7:0]	EEPROM Bank Cells [127:120]

(1) Bits [7:4] are don't care bits.

7.3.2.1.7 Programming EEPROM Banks

7.3.2.1.7.1 Programming Bank 0

Bank 0 is the only EEPROM bank which is programmable by both the M8051 and the Digital Interface. Below are the procedures used to setup the EEPROM cache and program the Bank 0 EEPROM using either the M8051 or the Digital Interface.

Programming Bank 0 With the 8051W

1. Check if EEPROM programming is not in progress
 - (a) Check EE_PROG_IN_PROG bit in EE_STATUS ESFR
2. If EEPROM programming is not in progress
 - (a) Read data from any location in Bank 0
 - (a) This will cause the Bank 0 contents to be transferred into cache

Notes:

 - If the latched bank select was not '000' before the first MOVX command was sent, then the M8051 will be held in a WAIT state for 8 μ s while an EEPROM Cache load takes place.
 - XRAMA[6:4] will latch the bank select value into the EEPROM controller.
 - The bank select will remain at this latched value until another MOVX command is issued with XRAMA[6:4] set to a different value.
 - (b) Updated the necessary data by writing to the appropriate locations in Bank 0
 - (a) Use MOVX commands to place data in external memory addresses 0x0000 → 0x000F. The bank select will be set to 0 since XRAMA[6:4] = '000'.
 - (c) Set MICRO_EEPROG bit to 1 in EE_CTRL ESFR
 - (a) This will program all the 16 bytes in the cache into EEPROM BANK 0

Programming Bank 0 With the Digital Interface

1. Activate the Digital Interface:
 - (a) Use the SPI, I2C, or OWI to write "0000_0011" to TEST_0E[7:0] This will reset the M8051 and switch memory access to the digital interface
2. Write Data to the EEPROM Cache:
 - (a) Select bank 0: Using SPI, I2C, or OWI, set TEST_0D[7:0] <- "0000_0000"
 - (b) Wait 8 μ s for EEPROM cache load to complete (optional: poll the EE_RED_IN_PROG bit in the EE_STATUS register until it returns to 0)
 - (c) Using any Digital Interface, fill the 16 bytes of EEPROM Cache with the data to be programmed.
 - Memory Page = "101" = 0x5
 - Address range = 0x01 → 0x0F
 - Refer to [Table 14](#) for EEPROM Cache address map.
 - Optional: Use OWI burst mode data transfer to transfer data to EEPROM Cache. See [OWI Burst Write Command \(EEPROM Cache Access\)](#)
3. Set the "EEPROM Bank Program Bit":
 - (a) TEST_0D[7:0] <- "0000_1000" 15-ms program timer begins
4. Poll EEPROM Program Status:
 - (a) Continuously poll the EE_PROG_IN_PROG bit in EE_STATUS register until it returns to 0
5. Check the Program Status: The EEPROM status bits for a Bank 0 EEPROM program operation should always show that Bank 0 received a good program with no CRC error regardless of actual program efficiency. There is no validation done on the CRC value calculated over the Bank 0 EEPROM data. In effect the "CRC error" and the "EEPROM Program good" status bits are not used for the Bank 0 program.

7.3.2.1.8 Programming Banks 1-5

1. Activate the Digital Interface:
 - (a) Use the SPI, I2C, or OWI to write "0000_0011" to TEST_0E[7:0]

This will reset the M8051 and switch memory access to the digital interface
2. Write Data to the EEPROM Cache:

- (a) Select bank to be programmed: Using SPI, I2C, or OWI, set TEST_0D[7:0] ← “0000_0bbb”, where bbb is a binary value from ‘001’ to ‘101’
 - (b) Wait 8 us for EEPROM Cache load to complete (optional: poll the EE_RED_IN_PROG bit in the EE_STATUS register until it returns to 0)
 - (c) Using any Digital Interface, fill the 16 bytes of EEPROM cache with the data to be programmed.
 - Memory Page = “101” = 0x5
 - Address range = 0x01 → 0x0F
 - Refer to [Table 14](#) for EEPROM Cache address map.
 - Optional: Use OWI burst mode data transfer to transfer data to EEPROM Cache. See [OWI Burst Write Command \(EEPROM Cache Access\)](#)
3. Set the “EEPROM Bank Program Bit”:
 - (a) TEST_0D[7:0] ← “0000_1bbb”, where bbb is the bank select value used in step 15-ms program timer begins
 4. Poll EEPROM Program Status:
 - (a) Continuously poll the EE_PROG_IN_PROG bit in EE_STATUS register until it returns to 0
 5. Check the Program Status: When EEPROM Programming is complete, read the EE_STATUS register bits 6 (CRC_ERR) and 5 (EEPROM_GOOD) to determine if the EEPROM values were programmed properly.

For a good program of the EEPROM:

“CRC_ERR” = 0

“EEPROM Program Good” = 1

7.3.2.1.9 CRC Calculation, Validation, and Storage for Banks 1–5

When programming bank 5, the cumulative CRC over the banks 1 through 4 and the first 8 bytes of bank 5 must be stored in the EEPROM Cache location at address 0x08. CRC values for Banks 1 through 4 are stored internally after programming these banks. Each of the banks 1–4 must be programmed prior to programming bank 5. This ensures that the data necessary to validate the cumulative CRC value has been stored prior to the bank 5 CRC validation. The device must NOT be powered down and NO main oscillator watchdog reset must occur between the programming of banks 1–4 and the programming of bank 5.

The CRC calculation pseudo code is as follows:

```

currentCRC8 = 0xFF; // Current value of CRC8
for NextData
D = NextData;
C = currentCRC8;
begin
  nextCRC8_BIT0 = D_BIT7 ^ D_BIT6 ^ D_BIT0 ^ C_BIT0 ^ C_BIT6 ^ C_BIT7;
  nextCRC8_BIT1 = D_BIT6 ^ D_BIT1 ^ D_BIT0 ^ C_BIT0 ^ C_BIT1 ^ C_BIT6;
  nextCRC8_BIT2 = D_BIT6 ^ D_BIT2 ^ D_BIT1 ^ D_BIT0 ^ C_BIT0 ^ C_BIT1 ^ C_BIT2 ^ C_BIT6;
  nextCRC8_BIT3 = D_BIT7 ^ D_BIT3 ^ D_BIT2 ^ D_BIT1 ^ C_BIT1 ^ C_BIT2 ^ C_BIT3 ^ C_BIT7;
  nextCRC8_BIT4 = D_BIT4 ^ D_BIT3 ^ D_BIT2 ^ C_BIT2 ^ C_BIT3 ^ C_BIT4;
  nextCRC8_BIT5 = D_BIT5 ^ D_BIT4 ^ D_BIT3 ^ C_BIT3 ^ C_BIT4 ^ C_BIT5;
  nextCRC8_BIT6 = D_BIT6 ^ D_BIT5 ^ D_BIT4 ^ C_BIT4 ^ C_BIT5 ^ C_BIT6;
  nextCRC8_BIT7 = D_BIT7 ^ D_BIT6 ^ D_BIT5 ^ C_BIT5 ^ C_BIT6 ^ C_BIT7;
end
currentCRC8 = nextCRC8_D8;
endfor
  
```

7.3.3 RAM Memory

This memory space is used for 8051W scratchpad memory, such as intermediate calculation results. It is a 256 byte memory space, and located at memory page 1.

7.3.4 SFR/ESFR Memory

The 8051W uses two types of memory storage, Special Function Registers (SFR) and External Special Function Registers (ESFR). The SFR registers are used for 8051W internal operations, and cannot be accessed external to the 8051W. The ESFR register exists on the same address space as the SFR, however these registers can be accessed via the digital interface. The ESFR registers are used for calibration, configuration, fault reporting and memory storage. The SFR/ESFR total memory space is 256 bytes, and they are located at memory page 2.

7.3.5 Test Register Memory

The test register memory space is used for diagnostic configuration, and testing for sensor calibration. The test registers are located at memory page 0, and can only be accessed by the Digital Interface.

7.4 General Purpose Input Output (GPIO) Pins

The GPIO_x pins have multiple functions, including general purpose inputs/outputs (GPIO), input capture, output compare or I2C. In the GPIO mode, the GPIO_x pins are connected directly to 8051W port pins. The state of the pins can then be controlled through software by setting the appropriate I/O port SFRs in the 8051W. [Table 15](#) shows the mapping of the GPIO_x pins to specific 8051W ports.

7.4.1 Setting the GPIO Functions

Table 15. GPIO_X Pin Functionality

PIN	8051W PORT	ALTERNATE FUNCTION 1	ALTERNATE FUNCTION 2
GPIO_1/IC_1/SDA	2.0	Input Capture 1	I2C Data
	Default	Set IC1_ACT to 1 in IC_OC_GPIO	Set DI_CTRL[1:0] = 0b01 in DI_CTRL
GPIO_2/IC_2	2.1	Input Capture 2	-
	Default	Set IC2_ACT to 1 in IC_OC_GPIO	
GPIO_3/OC_1/SCL	2.2	Output Compare 1	I2C Clock
	Default	Set OC1_ACT to 1 in IC_OC_GPIO	Set DI_CTRL[1:0] = 0b01 in DI_CTRL
GPIO_4/OC_2	2.3	Output Compare 2	
	Default	Set OC2_ACT to 1 in IC_OC_GPIO	
GPIO_5	3.2	—	—
	Default		

After power up or reset, the default configuration for all of these pins is the input GPIO function. To change the function of a pin a write command to the appropriate ESFR will automatically reconfigure it. [Table 15](#) shows the appropriate bits in each ESFR that need to be set to enable different functions for each GPIO pin.

As [Table 15](#) shows, some GPIOx pins can be configured for multiple alternate functionalities and therefore the device implements a priority level for each GPIO configuration. The priority level is as follows:

1. I²C
2. Input Capture / Output Compare
3. General Purpose I/Os

This means that if the IC1_ACT bit is set to 1 (enabling Input Capture 1 functionality on GPIO_1 pin) and the DI_CTRL[1:0] bits are set to 0x01 (enabling I2C functionality on GPIO_1) then the GPIO_1 pin is configured as I2C pin.

7.4.2 GPIO Buffers

The device includes five general purpose digital input/output buffers, one for each of the GPIO_x pin. The buffers can be configured to operate as standard 8051W I/O buffers or other alternate functions such as I2C and input capture/output compare. The direction of the buffers are controlled digitally depending on the mode of the GPIO_x pin.

The device also offers a strong drive mode which allows the user to override the digital control signals generated by the 8051W GPIO interface. This mode is set for a given IO buffer via the GPIO Strong Output Drive Mode ESFR. When a 1 is written to the ST_GPOx bit, a switch at the output of the Output buffer is always closed, providing a means to strongly pull up or down the voltage on the GPIO_x pin regardless of whether output data is low or high. It is important to note that the *GPIO Strong Output Drive Mode* ESFR can be set independent of the function assigned to the GPIO buffers. Strong drive mode should be disabled if the buffer should operate as an input or in I2C mode.

7.5 8051W UART

The TxD and RxD pins are connected to the 8051W UART. These pins can either be used for software debugging or for implementing application-specific protocols. Both the TxD and RxD pins have their respective unidirectional buffers.

7.6 DAC Output

The device includes two 12-bit digital to analog converters that produce a ratiometric output voltage with respect to the VDD supply. The digital input comes from the DAC 1 or DAC 2 registers, where the 4 MSBs reside in a separate address from the 8 LSBs. **In order to update the analog outputs on the VOUTx pins in a coherent manner, the software must update the MSBs first, followed by the LSBs.**

NOTE

Changes in the VDD voltage result in a proportional change in the output voltage because the current reference for the DAC is derived from VDD.

7.7 Input Capture and Output Compare

The device has two Input Capture and two Output Compare ports. [Table 15](#) shows the GPIO pins of the device that can be used for Input Capture and Output Compare ports. The capture and compare functionality uses a 16-bit Free Running Timer for the events.

7.7.1 Free Running Timer

The Free Running Timer is a 16-bit timer that is different from the 8051W native timers. The resolution of the Free Running Timer can be set to either 1 μ s/bit or 0.5 μ s/bit using 10_20_MHZ bit in Input Capture/Output Compare Control Register (IC_OC_CTRL) in the ESFR memory spacer.

The current value of the Free Running Timer can be accessed using the Free Running Timer Shadow Registers (FRTMSB & FRTLBSB). This register is only updated upon request, it is not continuously updated. When the IC_OC_TIM_LAT bit in the Input Capture/Output Compare Control Register (IC_OC_CTRL) is set to logic 1, the current value of the Free Running Timer is written to the Free Running Timer Shadow registers.

7.7.2 Input Capture

The device has 2 Input Capture ports. The Input Capture functionality can be enabled when the pin is configured to be a GPIO by setting ICx_ACT (x = 1,2) bits in the Input Capture/Output Compare GPIO Register (IC_OC_GPIO) in the ESFR memory space. When the user sets the corresponding bit to logic high, the GPIO pin is configured for Input Capture functionality automatically.

The Input Capture port can be configured to either capture the Free Running Timer value on a rising edge or falling edge using the ICx_EDGE bits in the Input Capture/Output Compare Control Register (IC_OC_CTRL) in the ESFR memory space. Both IC_1 and IC_2 each have unique 16-bit timer capture registers associated with them called Input Capture 1 Register and Input Capture 2 Register respectively. When the corresponding rising or falling edge occurs the Input Capture peripheral transfers the value of the Free Running Timer into the corresponding capture register and generates an interrupt to the 8051W.

7.7.3 Output Compare

The device has 2 Output Compare ports. The Output Compare functionality can be enabled when the pin is configured to be a GPIO by setting OCx_ACT (x = 1,2) bits in the Input Capture/Output Compare GPIO Register (IC_OC_GPIO) in the ESFR memory space.

The Output Compare port can be configured to either (1) Set the pin to High level when the match occurs or (2) Set the pin to Low level when the match occurs. The user can configure the desired state of the OC_1 and OC_2 pins at match using OC1_LVL and OC2_LVL bits in the Input Capture/Output Compare Control Register (IC_OC_CTRL).

Input Capture and Output Compare (continued)

Each Output Compare port has a unique 16-bit timer compare register associated with it. When the value programmed in the compare register matches the value of the Free Running Timer, the Output Compare peripheral changes the state of the corresponding pin to the configured value and generates a unique interrupt to the 8051W. This occurs every time the value in the Compare register matches the value of the Free Running Timer.

NOTE

For correct function of the output compare it is recommended that the MSB be updated first and then the LSB.

7.8 Diagnostics

This section describes the diagnostics.

7.8.1 Power Supply Diagnostics

The device includes modules to monitor the power supply for faults. The internal power rails that are monitored are AVDD, VBRG, and EEPROM charge pump. Please refer to the electrical specifications for the thresholds.

When a fault is detected, an appropriate bit in the PSMON1 and PSMON2 registers is set. If the faulty condition is removed, the fault bits will remain latched. To remove the fault the 8051W software should read the fault bit and write a logic zero back to the bit. In addition a system reset will clear the fault.

7.8.2 Resistive Bridge Sensor Connectivity Diagnostics

The device includes modules to monitor for sensor faults. Specifically, the device monitors the sensor pins for opens (including loss of connection from the sensor), short-to-ground, and short to sensor supply.

When a fault is detected, an appropriate bit in the AFEDIAG register is set. All three types of sensor faults will result in the setting of the same bit, meaning it is not possible to distinguish the type of fault that has occurred. Even after the faulty condition is removed, the fault bits remains latched. To remove the fault the 8051W software should read the fault bit and write a logic zero back to the bit. In addition a system reset will clear the fault.

Open Sensor Faults are detected through the use of an internal pulldown resistor. The value of the resistor can be configured using DIS_R1M and DIS_R2M bits in Decimator and Low Power Control Register (DECCTRL) in the ESFR memory space. This configurability allows the detection of open sensor faults for various Stage 1 Gain settings.

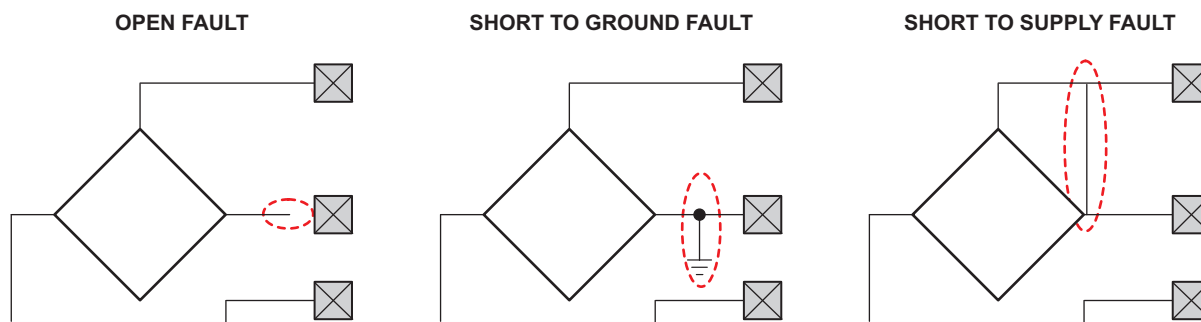

Figure 54. Resistive Bridge Sensor Connectivity Diagnostics

7.8.3 AFE Diagnostics

The device includes modules that verify that the input signal of each stage is within a certain range. This ensures that every stage of the signal chain is working normally. Overvoltage and undervoltage range flags are implemented in four locations along the signal chain (Sensor Input, Stage 1 Gain output, Stage 2 Gain output, and ADC Buffer output). When a fault is detected, the corresponding bit is set in the AFEDIAG registers. It is noted both overvoltage and undervoltage conditions set a common bit; i.e., it is not possible to distinguish between overvoltage and undervoltage.

Diagnostics (continued)

The AFE Diagnostics also includes the monitoring of the frequency of the Self-Oscillating Demodulator circuit used for capacitive sensor interface. If the frequency is less than 40 kHz (typical) or more than 1 MHz (typical), a fault flag is set in the AFEDIAG register. The monitoring of this frequency can be enabled or disabled using the CTOV_CLK_MON_EN bit in the ENABLE CONTROL register. Both over-frequency and under-frequency conditions set same bit which means it is not possible to distinguish which type of fault occurred that resulting in the flag.

The typical threshold values for these faults are in boxes in [Figure 55](#).

When a fault is detected, an appropriate bit in the AFEDIAG register is set. All sensor faults will result in the setting of the same bit, meaning there is no way to distinguish the type of fault. Even after the faulty condition is removed, the fault bits will remain latched. To remove the fault the 8051W software should read the fault bit and write a logic zero back to the bit. In addition a system reset will clear the fault.

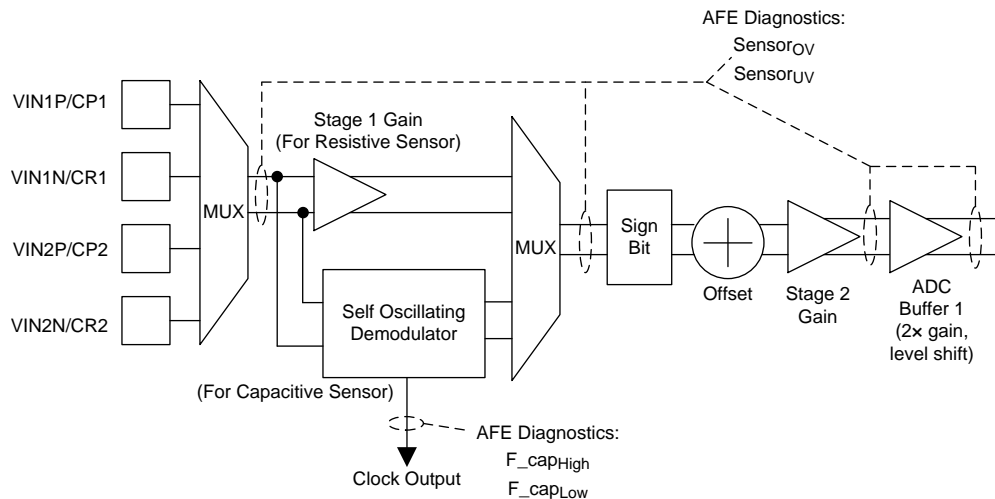

Figure 55. Block Diagram of AFE Diagnostics

7.8.4 Internal Capacitors for Capacitive Sensor Diagnostics

The device includes Cp and Cr Test capacitors that can be connected to the capacitive AFE via software control. This allows the software to check the integrity of the capacitive signal chain in the IC.

Figure [Figure 56](#) shows the block diagram with the Cp and Cr Test capacitors. The Cp Test capacitor is 10pF and Cr Test capacitor is 8pF.

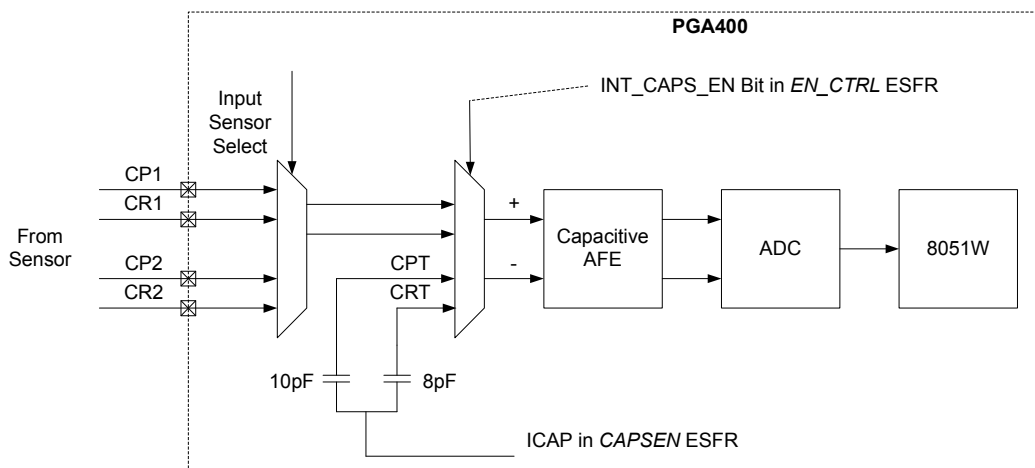

Figure 56. Internal Capacitors for Capacitive Sensor Diagnostics

Diagnostics (continued)

7.8.5 DAC Diagnostics

The device implements a “Loop Back” feature to check the integrity of the two DAC outputs. Figure 57 shows the block diagram representation of the Loop Back feature. This figure shows that DAC1 output is connected to positive side of the differential input while DAC2 is connected to negative side of the differential input.

The DAC outputs are voltage divided by a nominal factor of 6/11 before being connected to the AFE inputs.

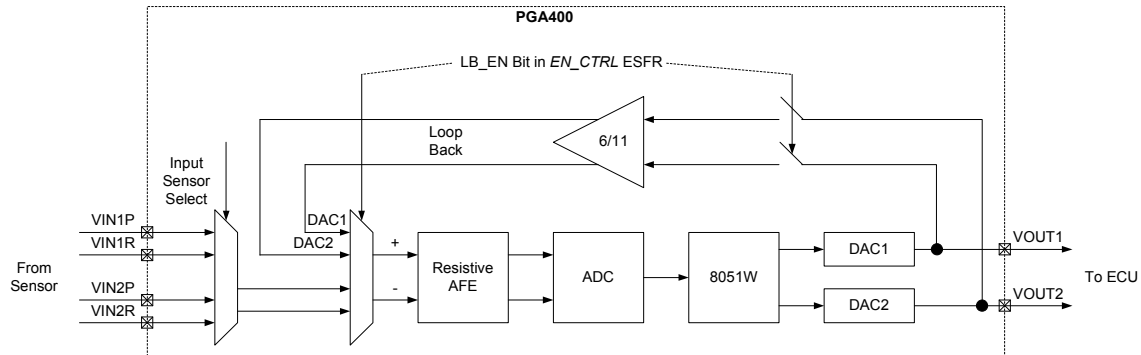

Figure 57. DAC Loop Back

DAC loop back is enabled by setting LB_EN bit in EN_CTRL to 1. In this mode, Sensor 1 Channel gain and offset settings are used. Note that ADC output represents the voltage difference between DAC1 and DAC2 outputs scaled by the voltage divider and the AFE gains/offsets.

Note that when LB_EN is set to 1, the AFE is switched to resistive mode, even if SEN_TYP bit is set to Capacitive mode.

The DAC outputs continue to be available on VOUT1 and VOUT2 pins in the Loop Back mode.

7.8.6 Harness Open Wire Diagnostics

PGA400 allows for Open Wire Diagnostics to be performed in the ECU. Specifically, the ECU can detect open VDD or Open GND wire by installing a pullup or pulldown on VOUT1 line.

Figure Figure 58 shows the possible harness open wire faults on VDD and GND pins.

Diagnostics (continued)

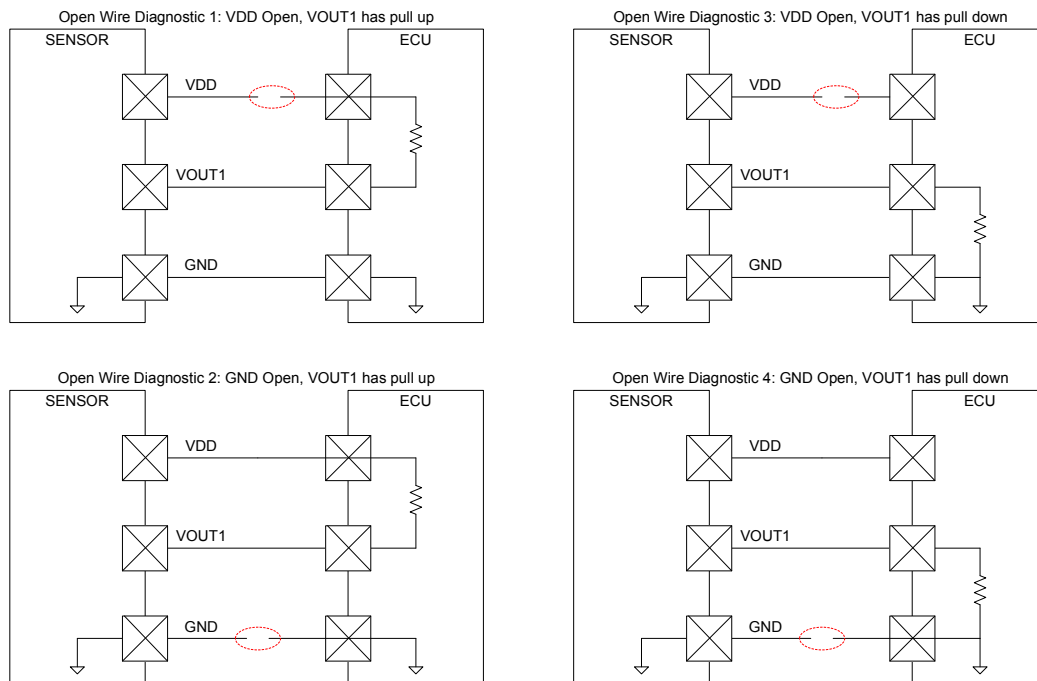

Figure 58. Harness Open Wire Diagnostics

Table [Table 16](#) summarizes the open wire diagnostics and the corresponding resistor pull values that allows the ECU to detect open harness faults.

Table 16. Typical Internal Pulldown Settings

Open Harness	ECU Pull Direction	Max Pull Value (KΩ)	State of PGA400 during fault condition	ECU Voltage Level (VOUT1/OWI pin)
VDD	Pull-Up	200	PGA400 is off. Leakage currents present (especially at high temp)	$VDD - (I_{leak1} * R_{pullup})$
GND	Pullup	N/A	PGA400 is off, all power rails pulled up to VDD	VDD
VDD	Pulldown	N/A	PGA400 is off, all power rails pulled down to ground	GND
GND	Pulldown	10	PGA400 is off, leakage current pushed into VOUT1 pin (thru the chip's ground).	$GND + (I_{leak2} * R_{pulldown})$

Note: VDD/GND Open faults cannot be detected on VOUT2 pin even with appropriate pullup/pulldown resistor.

7.8.7 EEPROM CRC and Trim Error

The 9th Byte in Bank 5 of the EEPROM stores the CRC for all the data in EEPROM Banks 1 through 5.

The user can verify the EEPROM CRC at any time by loading Banks 1 through 5 in sequence into the EEPROM Cache. When Bank 5 is loaded into the cache, the device automatically calculates the CRC and updates the CRC_ERR bit in EE_STATUS ESFR.

The device also has analog trim values. The validity of the analog trim values is checked on power up and before the 8051W reset is de-asserted. The validity of the trim values can be inferred using the TRIM_ERR bit in EE_STATUS ESFR.

Note that Banks 0 can be updated by software in the field, but the user has to maintain CRC (or checksum) for this bank using software.

7.8.8 RAM MBIST

The device implements RAM MBIST (Memory Built-In Self-Test). This diagnostic checks the integrity of the internal RAM on an on-demand basis.

The procedure to start this diagnostic and check for status is as below:

- 1. Set EN_IRAM_MBIST to 1 in EN_CTRL2 register. This starts the RAM MBIST.
- 2. Wait for IRAM_MBIST_DONE in RAM_MBIST_ST to be set to 1 by the RAM MBIST algorithm
- 3. Check IRAM_MBIST_FAIL bit in RAM_MBIST_ST register after IRAM_MBIST_DONE flag is set to 1. If IRAM_MBIST_FAIL is 1, then RAM MBIST failed, indicating faulty RAM. If IRAM_MBIST_FAIL is 0, then RAM has no faults.

The RAM MBIST can be run only once every power cycle.

NOTE

While the RAM MBIST is running, the 8051W should not access the RAM.

7.8.9 Main Oscillator Watchdog

There is watch dog monitor for the main oscillator clock whether using the internal 40-MHz oscillator or the external crystal input. When the frequency is outside the range of 35- to 45-MHz the entire device is reset. The main oscillator watchdog can be disabled using MAIN_OSC_WD_EN bit in the ENABLE CONTROL register.

7.8.10 Software Watchdog

The device also implements a software watchdog. This watchdog has to be serviced by software every 500ms. If the software does not service the watchdog within 500 ms of the last service, then the 8051W core is reset. The software services the watchdog by toggling the state of an internal pin between the two blocks. The state of this pin cannot be read back to the 8051W. If this function is not desired the software watchdog can be disabled using CPU_WD_EN bit in the ENABLE CONTROL register.

When the software watchdog times out and resets the 8051W, DAC1, and DAC2 registers are reset to 0, which causes VOUT1 and VOUT2 to be driven to 0 V. The remaining ESFRs retains the settings from prior to the reset events. This implies that CPU_WD_EN also remains set.

7.9 Low-Power Mode

The device has multiple low-power modes. In each mode, certain functional blocks can be turned on or off through the use of different ESFRs. [Table 17](#) lists which bits in each ESFR that disables certain blocks of the device.

Table 17. Low Power Control

CONTROL BIT	ESFR	CONTROL ACTION
VBRG_EN	SENCTRL	Enables/disables VBRG supply
DAC2_EN	DECCTRL	Enables/disables DAC2
AFE_EN	DECCTRL	Enables/disable AFE
EN_DI_IF_CLK	EN_CTRL2	Enable/disable digital interface
EN_EEPROM_CTRL_CLK	EN_CTRL2	Enable/disable EEPROM clock

The following blocks does not enter low power mode at any time:

- Microprocessor – The microprocessor continues to operate at the same frequency.
- OTP/EEPROM – The memory is kept alive and runs at the same speed VOUT1/OWI.

7.10 Register Maps

7.10.1 8051W Memory Map

The Memory block consists of SRAM, OTP, and EEPROM. The SRAM is used as storage for volatile software variables during program execution. The OTP consists of the program code and the EEPROM consists of calibrations.

Register Maps (continued)

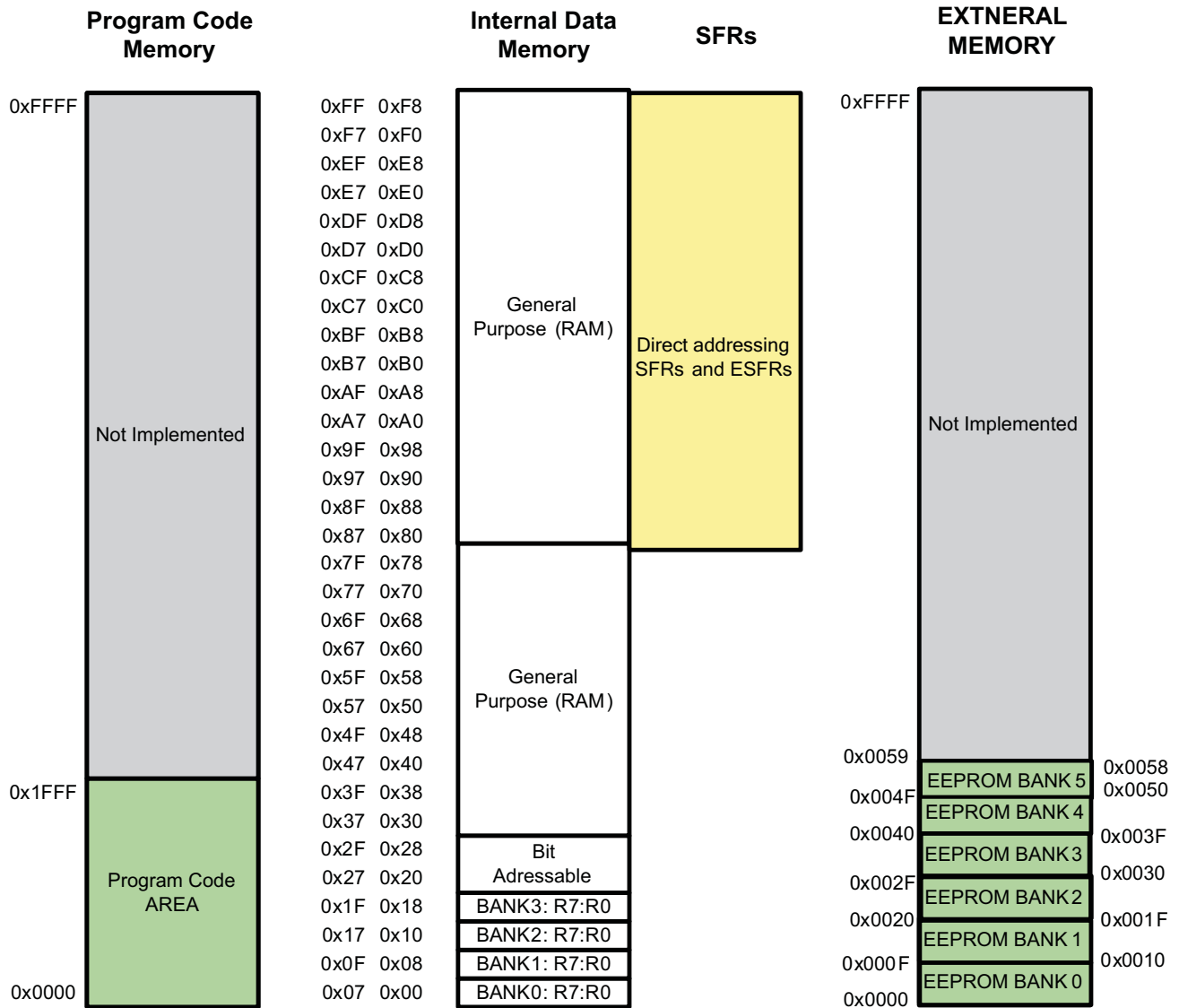

Figure 59. Memory Map

7.10.2 SFR

ADDRESS (hex)	D7	D6	D5	D4	D3	D2	D1	D0	R/W	POWER UP	DESCRIPTION (PROGRAMMABLE REGS)
80	P0<7>	P0<6>	P0<5>	P0<4>	P0<3>	P0<2>	P0<1>	P0<0>	R/W	0xFF	P0
81	SP<7>	SP<6>	SP<5>	SP<4>	SP<3>	SP<2>	SP<1>	SP<0>	R/W	0	SP
82	DPTR<7>	DPTR<6>	DPTR<5>	DPTR<4>	DPTR<3>	DPTR<2>	DPTR<1>	DPTR<0>	R/W	0	DPL
83	DPTR<15>	DPTR<14>	DPTR<13>	DPTR<12>	DPTR<11>	DPTR<10>	DPTR<9>	DPTR<8>	R/W	0	DPH
87	SMOD	-	-	-	GF1	GF0	PD	IDL	R/W	0	PCON
88	TF1	TR1	TF0	TR0	IE1	IT1	IE0	IT0	R/W	0	TCON
89	GATE1	CNT1	M1 (1)	M0 (1)	GATE0	CNT0	M1 (0)	M0 (0)	R/W	0	TMOD
8A	TL0<7>	TL0<6>	TL0<5>	TL0<4>	TL0<3>	TL0<2>	TL0<1>	TL0<0>	R/W	0	TL0
8B	TL1<7>	TL1<6>	TL1<5>	TL1<4>	TL1<3>	TL1<2>	TL1<1>	TL1<0>	R/W	0	TL1
8C	TH0<7>	TH0<6>	TH0<5>	TH0<4>	TH0<3>	TH0<2>	TH0<1>	TH0<0>	R/W	0	TH0
8D	TH1<7>	TH1<6>	TH1<5>	TH1<4>	TH1<3>	TH1<2>	TH1<1>	TH1<0>	R/W	0	TH1
90	P1<7>	P1<6>	P1<5>	P1<4>	P1<3>	P1<2>	P1<1>	P1<0>	R/W	0xFF	P1
98	SM0	SM1	SM2	REN	TB8	RB8	TI	RI	R/W	0	SCON
99	SBUF<7>	SBUF<6>	SBUF<5>	SBUF<4>	SBUF<3>	SBUF<2>	SBUF<1>	SBUF<0>	R/W	0	SBUF
A0	P2<7>	P2<6>	P2<5>	P2<4>	P2<3>	P2<2>	P2<1>	P2<0>	R/W	0xFF	P2
A8	EA	-	EI5	ES	ET1	EX1	ET0	EX0	R/W	0	IE0
B0	P3<7>	P3<6>	P3<5>	P3<4>	P3<3>	P3<2>	P3<1>	P3<0>	R/W	0	P3
B8	-	-	PI5	PS	PT1	PX1	PT0	PX0	R/W	0xFF	IP0
D0	CY	AC	F0	RS1	RS0	OV	F1	P	R/W	0	PSW
E0	ACC<7>	ACC<6>	ACC<5>	ACC<4>	ACC<3>	ACC<2>	ACC<1>	ACC<0>	R/W	0	ACC
E8	EI13	EI12	EI11	EI10	EI9	EI8	EI7	EI6	R/W	0	IE1
F0	B<7>	B<6>	B<5>	B<4>	B<3>	B<2>	B<1>	B<0>	R/W	0	B
F8	PI13	PI12	PI11	PI10	PI9	PI8	PI7	PI6	R/W	0	IP1

7.10.2.1 I/O PORTS(P0,P1,P2,P3)

P0, P1, P2 and P3 are latches used to drive the 32 quasi-bi-directional I/O lines. On reset they are all set to the value FF hex, which is input mode.

Table 18.

I/O PORTS(P0,P1,P2,P3)				Bit Addressable				
SFR:	0xB0		P3					
	BIT 7	BIT 6	BIT 5	BIT 4	BIT 3	BIT 2	BIT 1	BIT 0
	P3<7>	P3<6>	P3<5>	P3<4>	P3<3>	P3<2>	P3<1>	P3<0>
Access	r/w	r/w	r/w	r/w	r/w	r/w	w	R
At Reset	1	1	1	1	1	1	1	1

Table 19.

Some of the Port 3 have alternate function as shown below.								
	BIT 7	BIT 6	BIT 5	BIT 4	BIT 3	BIT 2	BIT 1	BIT 0
	-	-	T1	T0	NINT1	NINT0	TXD	RXD
	-	-	input	input	input	input	output	Input
BIT1: TXD	output		Serial Transmit Data from UART and transmit clock in UART mode 0.					
BIT0: RXD	input		Serial Receive Data to UART					

I/O PORTS(P0,P1,P2,P3)				Bit Addressable				
SFR:	0xA0		P2					
	BIT 7	BIT 6	BIT 5	BIT 4	BIT 3	BIT 2	BIT 1	BIT 0
	P2<7>	P2<6>	P2<5>	P2<4>	P2<3>	P2<2>	P2<1>	P2<0>
Access	r/w	r/w	r/w	r/w	r/w	r/w	r/w	r/w
At Reset	1	1	1	1	1	1	1	1

I/O PORTS(P0,P1,P2,P3)				Bit Addressable				
SFR:	0x90		P1					
	BIT 7	BIT 6	BIT 5	BIT 4	BIT 3	BIT 2	BIT 1	BIT 0
	P1<7>	P1<6>	P1<5>	P1<4>	P1<3>	P1<2>	P1<1>	P1<0>
Access	r/w	r/w	r/w	r/w	r/w	r/w	r/w	r/w
At Reset	1	1	1	1	1	1	1	1

I/O PORTS(P0,P1,P2,P3)				Bit Addressable				
SFR:	0x80		P0					
	BIT 7	BIT 6	BIT 5	BIT 4	BIT 3	BIT 2	BIT 1	BIT 0
	P0<7>	P0<6>	P0<5>	P0<4>	P0<3>	P0<2>	P0<1>	P0<0>
Access	r/w	r/w	r/w	r/w	r/w	r/w	r/w	r/w
At Reset	1	1	1	1	1	1	1	1

7.10.2.2 Stack Pointer (SP)

The SP register contains the Stack Pointer. The Stack Pointer is used to load the program counter into Internal Data Memory during LCALL and ACALL instructions and is used to retrieve the program counter from memory during RET and RETI instructions. Data may also be saved on or retrieved from the stack using PUSH and POP instructions. Instructions that use the stack automatically pre-increment or post-decrement the stack pointer so that the stack pointer always points to the last byte written to the stack, i.e. the top of the stack. On reset the Stack Pointer is set to 07 hex. It falls to the programmer to ensure that the location of the stack in Internal Data Memory does not interfere with other data stored therein.

Another use of the Scratchpad area is for the programmer's stack. This area is selected using the Stack Pointer (SP, SFR 81h). Whenever a call or interrupt is invoked, the return address is placed on the Stack. It also is available to the programmer for variables, etc., since the Stack can be moved and there is no fixed location within the RAM designated as Stack. The Stack Pointer defaults to 07h on reset and the user can then move it as needed. The SP will point to the last used value. Therefore, the next value placed on the Stack is put at SP + 1. Each PUSH or CALL increments the SP by the appropriate value and each POP or RET decrements it.

Table 20.

Stack Pointer (SP)				Not Bit Addressable				
SFR:	0x81			SP				
	BIT 7	BIT 6	BIT 5	BIT 4	BIT 3	BIT 2	BIT 1	BIT 0
	SP<7>	SP<6>	SP<5>	SP<4>	SP<3>	SP<2>	SP<1>	SP<0>
Access	r/w	r/w	r/w	r/w	r/w	r/w	r/w	r/w
At Reset	0	0	0	0	0	1	1	1

7.10.2.3 Data Pointer (DPTR)

The Data Pointer (DPTR) is a 16-bit register that may be accessed via the two SFR locations, Data Pointer High byte (DPH) and Data Pointer Low byte (DPL). Two true 16-bit operations are allowed on the Data Pointer - load immediate and increment. The Data Pointer is used to form 16-bit addresses for External Data Memory accesses (MOVX), for program byte moves (MOVC) and for indirect program jumps (JMP @A+DPTR). On reset the Data Pointer is set to 0000 hex.

Data Pointer (DPTR)				Not Bit Addressable				
SFR:	0x82			DPL				
	BIT 7	BIT 6	BIT 5	BIT 4	BIT 3	BIT 2	BIT 1	BIT 0
	DPTR<7>	DPTR<6>	DPTR<5>	DPTR<4>	DPTR<3>	DPTR<2>	DPTR<1>	DPTR<0>
Access	r/w	r/w	r/w	r/w	r/w	r/w	r/w	r/w
At Reset	0	0	0	0	0	0	0	0

SFR:	0x83			DPH				
	BIT 7	BIT 6	BIT 5	BIT 4	BIT 3	BIT 2	BIT 1	BIT 0
	DPTR<15>	DPTR<14>	DPTR<13>	DPTR<12>	DPTR<11>	DPTR<10>	DPTR<9>	DPTR<8>
Access	r/w	r/w	r/w	r/w	r/w	r/w	r/w	r/w
At Reset	0	0	0	0	0	0	0	0

7.10.2.4 Power Control Register (PCON)

Power Control Register (PCON)				Not Bit Addressable				
SFR:	0x87			PCON				
	BIT 7	BIT 6	BIT 5	BIT 4	BIT 3	BIT 2	BIT 1	BIT 0
	SMOD	-	-	-	GF1	GF0	PD	IDL
Access	r/w	r	r	r	r/w	r/w	r/w	r/w
At Reset	0	0	0	0	0	0	0	0

The bit definitions for this register are as follows.	
BIT7: SMOD	Double baud rate bit. For use, see the Serial Interface section below.
BIT3: GF1	General purpose flag bit.
BIT2: GF0	General purpose flag bit.
BIT1: PD	Power-Down bit. If 1, Power-Down mode is entered.
BIT0: IDL	Idle bit. If "1", Idle mode is entered.

7.10.2.5 Timer/Counter Control (TCON)

Two 16-bit timer/counters are provided. TCON and TMOD are used to set the mode of operation and to control the running and interrupt generation of the timer/counters. The timer/counter values are stored in two pairs of 8-bit registers (TL0, TH0, and TL1, TH1).

Timer/Counter Register (TCON)				Bit Addressable				
SFR:	0x88		TCON					
	BIT 7	BIT 6	BIT 5	BIT 4	BIT 3	BIT 2	BIT 1	BIT 0
	TF1	TR1	TF0	TR0	IE1	IT1	IE0	IT0
Access	r/w	r/w	r/w	r/w	r/w	r/w	r/w	r/w
At Reset	0	0	0	0	0	0	0	0

The bit definitions for this register are as follows.		
Timer1	BIT7: TF1	Timer 1 overflow flag. Set by hardware when Timer/Counter 1 overflows. Cleared by hardware when the processor calls the interrupt service routine.
Timer1	BIT6: TR1	Timer 1 run control. If "1", timer runs; if "0", timer is halted.
Timer0	BIT5: TF0	Timer 0 overflow flag. Set by hardware when Timer/Counter 0 overflows. Cleared by hardware when the processor calls the interrupt service routine.
Timer0	BIT4: TR0	Timer 0 run control. If "1", timer runs; if "0", timer is halted.
External Interrupt1	BIT3: IE1	External Interrupt 1 edge flag. Set by hardware when an External Interrupt 1 edge is detected.
External Interrupt1	BIT2: IT1	External Interrupt 1 control bit. If "1", External Interrupt 1 is "edge-triggered"; if "0", External Interrupt 1 is "level triggered"
External Interrupt0	BIT1: IE0	External Interrupt 0 edge flag. Set by hardware when an External Interrupt 0 edge is detected.
External Interrupt0	BIT0: IT0	External Interrupt 1 control bit. If "1", External Interrupt 1 is "edge-triggered"; if "0", External Interrupt 1 is "level triggered"

7.10.2.6 Timer/Counter Mode (TMOD)

Timer/Counter Mode (TMOD)				Not Bit Addressable				
SFR:	0x89		TCON					
	BIT 7	BIT 6	BIT 5	BIT 4	BIT 3	BIT 2	BIT 1	BIT 0
	GATE1	CNT1	M1 (1)	M0 (1)	GATE0	CNT0	M1 (0)	M0 (0)
Access	r/w	r/w	r/w	r/w	r/w	r/w	r/w	r/w
At Reset	0	0	0	0	0	0	0	0

The bit definitions for this register are as follows.		
Timer1	BIT7: GATE1	Timer 1 gate flag. When TCON.6 is set and GATE1= 1, Timer/Counter 1 will only run if NINT1 pin is 1 (hardware control). When GATE1= 0, Timer/Counter 1 will only run if TCON.6 = 1 (software control).
Timer1	BIT6: CNT1	Timer/Counter 1 selector. If 0, input is from internal system clock; if "1", input is from T1 pin.
Timer1	BIT5: M1(1)	Timer 1 Mode control bit M1.
Timer1	BIT4: M0(1)	Timer 1 Mode control bit M0.
Timer0	BIT3: GATE0	Timer 0 gate flag. When TCON.4 is set and GATE0= 1, Timer/Counter 0 will only run if NINT0 pin is 1 (hardware control). When GATE0 = 0, Timer/Counter 0 will only run if TCON.4 = 1 (software control).
Timer0	BIT2: CNT0	Timer/Counter 0 selector. If 0, input is from internal system clock; if "1", input is from T0 pin.
Timer0	BIT1: M1(0)	Timer 0 Mode control bit M1.
Timer0	BIT0: M0(0)	Timer 0 Mode control bit M0.

For both timer/counters, the mode bits M0 and M1 apply as follows:		
M1	M0	Operating Mode
0	0	13-bit timer/counter (M8048 compatible mode).
0	1	16-bit timer/counter.
1	0	8-bit auto-reload timer/counter.
1	1	Timer 0 is split into two halves. TL0 is an 8-bit timer/counter controlled by the standard Timer 0 control bits. TH0 is an 8-bit timer/counter controlled by the standard Timer 1 control bits. TH1 and TL1 are held (Timer 1 is stopped).

7.10.2.7 Timer/Counter Data (TL0 TL1 TH0 TH1)

TL0 and TH0 are the low and high bytes of Timer/Counter 0 respectively. TL1 and TH1 are the low and high bytes of Timer/Counter 1 respectively. In Mode 2, the TL register is an 8-bit counter and TH stores the reload value. On reset all timer/counter registers are 00 hex.

Timer/Counter Data (TL0 TL1 TH0 TH1)				Not Bit Addressable					
SFR:	0x8A	TL0							
	BIT 7	BIT 6	BIT 5	BIT 4	BIT 3	BIT 2	BIT 1	BIT 0	
	TL0<7>	TL0<6>	TL0<5>	TL0<4>	TL0<3>	TL0<2>	TL0<1>	TL0<0>	
Access	r/w	r/w	r/w	r/w	r/w	r/w	r/w	r/w	
At Reset	0	0	0	0	0	0	0	0	

SFR:	0x8B	TL1							
	BIT 7	BIT 6	BIT 5	BIT 4	BIT 3	BIT 2	BIT 1	BIT 0	
	TL1<7>	TL1<6>	TL1<5>	TL1<4>	TL1<3>	TL1<2>	TL1<1>	TL1<0>	
Access	r/w	r/w	r/w	r/w	r/w	r/w	r/w	r/w	
At Reset	0	0	0	0	0	0	0	0	

SFR:	0x8C	TH0							
	BIT 7	BIT 6	BIT 5	BIT 4	BIT 3	BIT 2	BIT 1	BIT 0	
	TH0<7>	TH0<6>	TH0<5>	TH0<4>	TH0<3>	TH0<2>	TH0<1>	TH0<0>	
Access	r/w	r/w	r/w	r/w	r/w	r/w	r/w	r/w	
At Reset	0	0	0	0	0	0	0	0	

SFR:	0x8D	TH1							
	BIT 7	BIT 6	BIT 5	BIT 4	BIT 3	BIT 2	BIT 1	BIT 0	
	TH1<7>	TH1<6>	TH1<5>	TH1<4>	TH1<3>	TH1<2>	TH1<1>	TH1<0>	
Access	r/w	r/w	r/w	r/w	r/w	r/w	r/w	r/w	
At Reset	0	0	0	0	0	0	0	0	

The timer clock resolution is 5MHz.

7.10.2.8 UART Control (SCON)

The UART uses two SFRs, SCON and SBUF. SCON is the control register, SBUF the data register. Data is written to SBUF for transmission and SBUF is read to obtain received data. The received data and transmitted data registers are independent.

UART Control (SCON)				Bit Addressable					
SFR:	0x98	SCON							
	BIT 7	BIT 6	BIT 5	BIT 4	BIT 3	BIT 2	BIT 1	BIT 0	
	SM0	SM1	SM2	REN	TB8	RB8	TI	RI	
Access	r/w	r/w	r/w	r/w	r/w	r/w	r/w	r/w	
At Reset	0	0	0	0	0	0	0	0	

PGA400-Q1

SLDS186A – MARCH 2012 – REVISED JULY 2016

www.ti.com

The bit definitions for this register are as follows.	
BIT7: SM0	UART mode specifier.
BIT6: SM1	UART mode specifier.
BIT5: SM2	UART mode specifier.
BIT4: REN	If "1", enables reception; if "0", disables reception.
BIT3: TB8	In Modes 2 and 3, this is the 9th data bit sent.
BIT2: RB8	In Modes 2 and 3, this is the 9th data bit received. In Mode 1, if SM2 = 0, this is the stop bit received. In Mode 0, this bit is not used.
BIT1: TI	Transmit interrupt flag. This is set by hardware at the end of the 8th bit in Mode 0, or at the beginning of the stop bit in other modes. Must be cleared by software. beginning of the stop bit in other modes. Must be cleared by software.
BIT0: RI	Receive interrupt flag. This is set by hardware at the end of the 8th bit in Mode 0, or at the half point of the stop bit in other modes. Must be cleared by software.

The mode control bits operate as follows.

Mode	SM0	SM1	Operating Mode	Baud Rate
Mode 0	0	0	Mode 0: 8 bit shift register. $\text{ftimer_clk} / 2$	$\text{Baud Rate} = \text{ftimer_clk} / 2$
Mode 1	0	1	Mode 1: 8 bit UART.	$\text{Baud Rate} = (\text{SMOD} + 1) * \text{ftimer_clk} / (32 * (256 - \text{TH1}))$
Mode 2	1	0	Mode 2: 9 bit UART.	$\text{Baud Rate} = (\text{SMOD} + 1) * \text{ftimer_clk} / 64$
Mode 3	1	1	Mode 3: 9 bit UART.	$\text{Baud Rate} = (\text{SMOD} + 1) * \text{ftimer_clk} / (32 * (256 - \text{TH1}))$

where ftimer_clk is the frequency of the `TIMER_CLK` input (5MHz).

SM2 enables multi-processor communication over a single serial line and modifies the above as follows. In Modes 2 & 3, if SM2 is set then the receive interrupt will not be generated if the received 9th data bit is 0. In Mode 1, the receive interrupt will not be generated unless a valid stop bit is received. In Mode 0, SM2 should be 0.

7.10.2.9 UART Data (SBUF)

This register is used for both transmit and receive data. Transmit data is written to this location and receive data is read from this location, but the two paths are independent.

UART Data (SBUF)				Not Bit Addressable				
SFR:	0x99			SBUF				
	BIT 7	BIT 6	BIT 5	BIT 4	BIT 3	BIT 2	BIT 1	BIT 0
	SBUF<7>	SBUF<6>	SBUF<5>	SBUF<4>	SBUF<3>	SBUF<2>	SBUF<1>	SBUF<0>
Access	r/w	r/w	r/w	r/w	r/w	r/w	r/w	r/w
At Reset	0	0	0	0	0	0	0	0

7.10.2.10 Interrupt Enable Register 0 (IE)

Interrupt Enable Register 0 (IE)				Bit Addressable				
SFR:	0xA8			IE				
	BIT 7	BIT 6	BIT 5	BIT 4	BIT 3	BIT 2	BIT 1	BIT 0
	EA	-	EI5	ES	ET1	EX1	ET0	EX0
Access	r/w	r	r/w	r/w	r/w	r/w	r/w	r/w
At Reset	0	0	0	0	0	0	0	0

For each bit in this register, a 1 enables the corresponding interrupt and a 0 disables it.		
BIT7: EA	Enable or disable all interrupt bits.	
BIT5: EI5	Enable External Interrupt 5.	
BIT4: ES	Enable Serial Port interrupt.	
BIT3: ET1	Enable Timer 1 overflow interrupt.	
BIT2: EX1	Enable External Interrupt 1.	
BIT1: ET0	Enable Timer 0 overflow interrupt.	
BIT0: EX0	Enable External Interrupt 0.	

7.10.2.11 Interrupt Enable Register 1 (IE1)

Interrupt Enable Register 1 (IE1)				Bit Addressable					
SFR:	0xE8		IE1						
	BIT 7	BIT 6	BIT 5	BIT 4	BIT 3	BIT 2	BIT 1	BIT 0	
	EI13	EI12	EI11	EI10	EI9	EI8	EI7	EI6	
Access	r/w	r/w	r/w	r/w	r/w	r/w	r/w	r/w	
At Reset	0	0	0	0	0	0	0	0	

For each bit in this register, a 1 enables the corresponding interrupt and a 0 disables it.		
BIT7: EI13	Enable External Interrupt 13.	
BIT6: EI12	Enable External Interrupt 12.	
BIT5: EI11	Enable External Interrupt 11.	
BIT4: EI10	Enable External Interrupt 10.	
BIT3: EI9	Enable External Interrupt 9.	
BIT2: EI8	Enable External Interrupt 8.	
BIT1: EI7	Enable External Interrupt 7.	
BIT0: EI6	Enable External Interrupt 6.	

7.10.2.12 Interrupt Priority Register 0 (IP)

Interrupt Priority Register 0 (IP0)				Bit Addressable					
SFR:	0xB8		IP						
	BIT 7	BIT 6	BIT 5	BIT 4	BIT 3	BIT 2	BIT 1	BIT 0	
	-	-	PI5	PS	PT1	PX1	PT0	PX0	
Access	r	r	r/w	r/w	r/w	r/w	r/w	r/w	
At Reset	0	0	0	0	0	0	0	0	

For each bit in this register, a 1 selects high priority for the corresponding interrupt and a 0 selects low priority. The allocation of interrupts to bits is as follows.		
BIT5: PI5	Select priority for External Interrupt 5.	
BIT4: PS	Select priority for Serial Port interrupt.	
BIT3: PT1	Select priority for Timer 1 overflow interrupt.	
BIT2: PX1	Select priority for External Interrupt 1.	
BIT1: PT0	Select priority for Timer 0 overflow interrupt.	
BIT0: PX0	Select priority for External Interrupt 0.	
While an interrupt is being serviced, it may only be interrupted by a higher priority interrupt.		

7.10.2.13 Interrupt Priority Register 1 (IP1)

Interrupt Priority Register 1 (IP1)				Bit Addressable				
SFR:	0xF8		IP1					
	BIT 7	BIT 6	BIT 5	BIT 4	BIT 3	BIT 2	BIT 1	BIT 0
	PI13	PI12	PI11	PI10	PI9	PI8	PI7	PI6
Access	r/w	r/w	r/w	r/w	r/w	r/w	r/w	r/w
At Reset	0	0	0	0	0	0	0	0

For each bit in this register, a 1 selects high priority for the corresponding interrupt and a 0 selects low priority. The allocation of interrupts to bits is as follows. For each bit in this register, a 1 enables the corresponding interrupt and a 0 disables it.

	BIT7: PI13	Select priority for External Interrupt 13.
	BIT6: PI12	Select priority for External Interrupt 12.
	BIT5: PI11	Select priority for External Interrupt 11.
	BIT4: PI10	Select priority for External Interrupt 10.
	BIT3: PI9	Select priority for External Interrupt 9.
	BIT2: PI8	Select priority for External Interrupt 8.
	BIT1: PI7	Select priority for External Interrupt 7.
	BIT0: PI6	Select priority for External Interrupt 6.

While an interrupt is being serviced, it may only be interrupted by a higher priority interrupt.

7.10.2.14 Program Status Word (PSW)

Program Status Word (PSW)				Bit Addressable				
SFR:	0xD0		PSW					
	BIT 7	BIT 6	BIT 5	BIT 4	BIT 3	BIT 2	BIT 1	BIT 0
	CY	AC	F0	RS1	RS0	OV	F1	P
Access	r/w	r/w	r/w	r/w	r/w	r/w	r/w	r/w
At Reset	0	0	0	0	0	0	0	0

This register contains status information resulting from CPU and ALU operation. The bit definitions are given below:

	BIT7: CY	ALU carry flag.
	BIT6: AC	ALU auxiliary carry flag.
	BIT5: F0	General purpose user-definable flag.
	BIT4: RS1	Register Bank Select bit 1.
	BIT3: RS0	Register Bank Select bit 0.
	BIT2: OV	ALU overflow flag.
	BIT1: F1	User-definable flag.
	BIT0: P	Parity flag. Set each instruction cycle to indicate odd/even parity in the accumulator.

The Register Bank Select bits operate as follows.

RS1	RS0	Register Bank Select
0	0	RB0: Registers from 00 - 07 hex.
0	1	RB1: Registers from 08 - 0F hex.
1	0	RB2: Registers from 10 - 17 hex.
1	1	RB3: Registers from 18 - 1F hex.

7.10.2.15 Accumulator (ACC)

This register provides one of the operands for most ALU operations. It is denoted as "A" in the instruction table.

Accumulator (ACC)				Bit Addressable					
SFR:	0xE0	ACC							
	BIT 7	BIT 6	BIT 5	BIT 4	BIT 3	BIT 2	BIT 1	BIT 0	
	ACC<7>	ACC<6>	ACC<5>	ACC<4>	ACC<3>	ACC<2>	ACC<1>	ACC<0>	
Access	r/w	r/w	r/w	r/w	r/w	r/w	r/w	r/w	
At Reset	0	0	0	0	0	0	0	0	

7.10.2.16 Register (B)

This register provides the second operand for multiply or divide instructions. Otherwise, it may be used as a scratch pad register.

B Register (B)				Bit Addressable					
SFR:	0xF0	B							
	BIT 7	BIT 6	BIT 5	BIT 4	BIT 3	BIT 2	BIT 1	BIT 0	
	B<7>	B<6>	B<5>	B<4>	B<3>	B<2>	B<1>	B<0>	
Access	r/w	r/w	r/w	r/w	r/w	r/w	r/w	r/w	
At Reset	0	0	0	0	0	0	0	0	

PGA400-Q1

SLDS186A – MARCH 2012 – REVISED JULY 2016

www.ti.com
7.10.3 ESFR

The ESFRs are External Special Function Registers that are external to the 8051W core and are specific to PGA400-Q1.

ADDRESS (hex)	D7	D6	D5	D4	D3	D2	D1	D0	R/W	POWER UP	DESCRIPTION (PROGRAMMABLE REGS)
91	PSMON[7]	PSMON[6]	PSMON[5]	PSMON[4]	PSMON[3]	PSMON[2]	PSMON[1]	PSMON[0]	R/W	0x00	PSMON1
92	PSMON[15]	PSMON[14]	PSMON[13]	PSMON[12]	PSMON[11]	PSMON[10]	PSMON[9]	PSMON[8]	R/W	0x00	PSMON2
93	AFEDIAG[7]	AFEDIAG[6]	AFEDIAG[5]	AFEDIAG[4]	AFEDIAG[3]	AFEDIAG[2]	AFEDIAG[1]	AFEDIAG[0]	R/W	0x00	AFEDIAG
94	-	-	-	-	-	-	-	CPU_WD_RES ET	R/W	0xx0	CLKDIAG
A1	S1_G1[2]	S1_G1[1]	S1_G1[0]	S1_G2[4]	S1_G2[3]	S1_G2[2]	S1_G2[1]	S1_G2[0]	R/W	0xx0	SEN1GAIN
A2	S2_G1[2]	S2_G1[1]	S2_G1[0]	S2_G1[4]	S2_G1[3]	S2_G1[2]	S2_G1[1]	S2_G1[0]	R/W	0x00	SEN2GAIN
A3	S1_OS [7]	S1_OS [6]	S1_OS [5]	S1_OS [4]	S1_OS [3]	S1_OS [2]	S1_OS [1]	S1_OS [0]	R/W	0x00	SEN1OFF1
A4	S1_OS[9]	S1_OS[8]	S1_OS[5]	S1_OS[4]	S1_OS[3]	S1_OS[2]	S1_OS[1]	S1_OS[0]	R/W	0x00	SEN1OFF2
A5	S2_OS [7]	S2_OS [6]	S2_OS [5]	S2_OS [4]	S2_OS [3]	S2_OS [2]	S2_OS [1]	S2_OS [0]	R/W	0x00	SEN2OFF1
A6	S2_OS[9]	S2_OS[8]	S2_OS[5]	S2_OS[4]	S2_OS[3]	S2_OS[2]	S2_OS[1]	S2_OS[0]	R/W	0x00	SEN2OFF2
A7	SEN_TYP	CI[2]	CI[1]	CI[0]	CV[1]	CV[0]	CR[1]	CR[0]	R/W	0x00	CAPSEN
A9	SEN_CHNL	S1_INV	S2_INV	ADC_BUF	TEMP_SEN	XTAL_EN	VBRG_EN	-	R/W	0x00	SENCTRL
AA	ST_TX	-	ST_GPO5	ST_GPO4	ST_GPO3	ST_GPO2	ST_GPO1	-	R/W	0x00	GPIO_STRG
AB	CLKCNT[7]	CLKCNT[6]	CLKCNT[5]	CLKCNT[4]	CLKCNT[3]	CLKCNT[2]	CLKCNT[1]	CLKCNT[0]	R/W	0x00	CTOV_VLK_CN T
B1	ADC[15]	ADC[14]	ADC[13]	ADC[12]	ADC[11]	ADC[10]	ADC[9]	ADC[8]	R/W	0x00	ADCMSB
B2	ADC[7]	ADC[6]	ADC[5]	ADC[4]	ADC[3]	ADC[2]	ADC[1]	ADC[0]	R/W	0x00	SDCLSB
B3	-	-	-	-	-	LD_SADC1	LD_SADC2	LD_TADC	R/W	0x00	LD_DEC
B7	-	-	-	DAC1[11]	DAC1[10]	DAC1[9]	DAC1[8]	PX0	R/W	0x00	DAC1MSB
B9	DAC1[7]	DAC1[6]	DAC1[5]	DAC1[4]	DAC1[3]	DAC1[2]	DAC1[1]	DAC1[0]	R/W	0x00	DAC1LSB
BA	-	-	-	-	DAC2[11]	DAC2[10]	DAC2[9]	DAC2[8]	R/W	0x00	DAC2MSB
BB	DAC2[7]	DAC2[6]	DAC2[5]	DAC2[4]	DAC2[3]	DAC2[2]	DAC2[1]	DAC2[0]	R/W	0x00	DAC2LSB
BC	-	-	DAC2_EN	AFE_EN	-	-	OSR[1]	OSR[0]	R/W	0x00	DECCTRL
C0	-	-	IC_OC_TIM_LA T	OC2_LVL	OC1_LVL	IC2_EDGE	IC1_EDGE	10_20_MHZ	R/W	0x00	IC_OC_CTRL
C1	IC1[15]	IC1[14]	IC1[13]	IC1[12]	IC1[11]	IC1[10]	IC1[9]	IC1[8]	R/W	0x00	IC1MSB
C2	IC1[7]	IC1[6]	IC1[5]	IC1[4]	IC1[3]	IC1[2]	IC1[1]	IC1[0]	R/W	0x00	IC1LSB
C3	IC2[15]	IC2[14]	IC2[13]	IC2[12]	IC2[11]	IC2[10]	IC2[9]	IC2[8]	R/W	0x00	IC2MSB
C4	IC2[7]	IC2[6]	IC2[5]	IC2[4]	IC2[3]	IC2[2]	IC2[1]	IC2[0]	R/W	0x00	IC2ISB
C5	OC1[15]	OC1[14]	OC1[13]	OC1[12]	OC1[11]	OC1[10]	OC1[9]	OC1[8]	R/W	0x00	OC1MSB
C6	OC1[7]	OC1[6]	OC1[5]	OC1[4]	OC1[3]	OC1[2]	OC1[1]	OC1[0]	R/W	0x00	OC1LSB
C7	-	-	-	-	OC2_ACT	OC1_ACT	IC2_ACT	IC1_ACT	R/W	0x00	IC_OC_GPIO
C9	OC2[15]	OC2[14]	OC2[13]	OC2[12]	OC2[11]	OC2[10]	OC2[9]	OC2[8]	R/W	0x00	OC2MSB

ADDRESS (hex)	D7	D6	D5	D4	D3	D2	D1	D0	R/W	POWER UP	DESCRIPTION (PROGRAMMABLE REGS)
CA	OC2[7]	OC2[6]	OC2[5]	OC2[4]	OC2[3]	OC2[2]	OC2[1]	OC2[0]	R/W	0x00	OC2LSB
CB	FRT[15]	FRT[14]	FRT[13]	FRT[12]	FRT[11]	FRT[10]	FRT[9]	FRT[8]	R/W	0x00	FRTMSB
CC	FRT[7]	FRT[6]	FRT[5]	FRT[4]	FRT[3]	FRT[2]	FRT[1]	FRT[0]	R/W	0x00	FRTLBSB
D3	COMBUF[7]	COMBUF[6]	COMBUF[5]	COMBUF[4]	COMBUF[3]	COMBUF[2]	COMBUF[1]	COMBUF[0]	R/W	0x00	COMBUF
D4	-	-	-	-	OWI_DEGLITCH_SEL	OWI_XCR_EN	DI_CTRL[1]	DI_CTRL[0]	R/W	0x00	DI_CTRL
D5	-	-	-	INT_CAPS_EN	LB_EN	CTOV_CLK_MON_EN	MAIN_OSC_WD_EN	CPU_WD_EN	R/W	0x00	EN_CTRL
D6						EN_IRAM_MBIST	EN_DI_IF_CLK	EN_EEPROM_CTRL_CLK	R/W	0x00	EN_CTRL2
D7	-	-	-	-	-	-	IRAM_MBIST_FAIL	IRAM_MBIST_DONE	R/W	0x00	RAM_MBIST_STATUS
E1	TRIM_ERR	CRC_ERR	EEPROG_GOOD	EE_READ_IN_PROG	EE_PROG_IN_PROG	EE_BNK[2]	EE_BNK[1]	EE_BNK[0]	R/W	0x00	EE_STATUS
E2	-	-	-	-	-	-	-	MICRO_EEPROM	R/W	0x00	EE_CTRL

7.10.3.1 PSMON Diagnostics Status (PSMON1, PSMON2)

PSMON STATUS (PSMON1, PSMON2)				Not Bit Addressable				
ESFR:	0x91	PSMON1						
	BIT 7	BIT 6	BIT 5	BIT 4	BIT 3	BIT 2	BIT 1	BIT 0
	PSMON[7]	PSMON[6]	PSMON[5]	PSMON[4]	PSMON[3]	PSMON[2]	PSMON[1]	PSMON[0]
Access	r	r	r	r	r	r	r	r
At Reset	0	0	0	0	0	0	0	0
ESFR:	0x92	PSMON2						
	BIT 7	BIT 6	BIT 5	BIT 4	BIT 3	BIT 2	BIT 1	BIT 0
	PSMON[15]	PSMON[14]	PSMON[13]	PSMON[12]	PSMON[11]	PSMON[10]	PSMON[9]	PSMON[8]
Access	r	r	r	r	r	r	r	r
At Reset	0	0	0	0	0	0	0	0

Bit Definitions		
PSMON2	BIT 0:PSMON[0]	1: AVDD Overvoltage
	BIT 1:PSMON[1]	1: AVDD Undervoltage
	BIT 2:PSMON[2]	-
	BIT 3:PSMON[3]	-
	BIT 4:PSMON[4]	1: VBRG Overvoltage
	BIT 5:PSMON[5]	1: VBRG Undervoltage
	BIT 6:PSMON[6]	-
	BIT 7:PSMON[7]	-
PSMON1	BIT 0:PSMON[8]	1: EEPROM Overvoltage
	BIT 1:PSMON[9]	1: EEPROM Undervoltage
	BIT 2:PSMON[10]	-
	BIT 3:PSMON[11]	-
	BIT 4:PSMON[12]	-
	BIT 5:PSMON[13]	-
	BIT 6:PSMON[14]	-
	BIT 7:PSMON[15]	-

7.10.3.2 AFE Diagnostics Status (AFEDIAG)

AFE STATUS (AFEDIAG)				Not Bit Addressable				
ESFR:	0x93		AFEDIAG					
	BIT 7	BIT 6	BIT 5	BIT 4	BIT 3	BIT 2	BIT 1	BIT 0
	AFEDIAG[7]	AFEDIAG[6]	AFEDIAG[5]	AFEDIAG[4]	AFEDIAG[3]	AFEDIAG[2]	AFEDIAG[1]	AFEDIAG[0]
Access		r	r	r	r	r	r	r
At	0	0	0	0	0	0	0	0

Bit Definitions		
PSMON2	BIT 0:AFEDIAG[0]	1: Res Sensor Open / Short to Supply/ Short to Gnd 0: Normal
	BIT 1:AFEDIAG[1]	1: AFE Stage1 Output / C2V Output Over Range Flag 0: Normal
	BIT 2:AFEDIAG[2]	1: AFE Stage2 Output Over Range Flag 0: Normal
	BIT 3:AFEDIAG[3]	1: Normal 0: ADC Input Over Range Flag
	BIT 4:AFEDIAG[4]	-
	BIT 5:AFEDIAG[5]	-
	BIT 6:AFEDIAG[6]	-
	BIT 7:AFEDIAG[7]	1: Capacitive Sensor Clock High/Low flag (Sensor fault Detection) 0: Normal

7.10.3.3 CPU Watchdog (CLKDIAG)

MICRO RESET (MICRORESET)				Not Bit Addressable				
ESFR:	0x94		MICRORESET					
	BIT 7	BIT 6	BIT 5	BIT 4	BIT 3	BIT 2	BIT 1	BIT 0
	-	-	-	-	-	-	-	CPU_WD_RESE T
Access		R	r	r	r	r	r	r
At	0	0	0	0	0	0	0	0
Reset								

Bit Definitions		
CLKDIAG	BIT 0:CPU_WD_RESET	1: Microprocessor is in reset 0: Microprocessor is not reset
	BIT 1:	-
	BIT 2:	-
	BIT 3:	-
	BIT 4:	-
	BIT 5:	-
	BIT 6:	-
	BIT 7:	

7.10.3.4 Sensor 1 Gain Register (SEN1GAIN)

SEN1GAIN				Not Bit Addressable				
ESFR:	0xA1	SEN1GAIN						
	BIT 7	BIT 6	BIT 5	BIT 4	BIT 3	BIT 2	BIT 1	BIT 0
	S1_G1[2]	S1_G1[1]	S1_G1[0]	S1_G2[4]	S1_G2[3]	S1_G2[2]	S1_G2[1]	S1_G2[0]
Access	r/w	r/w	r/w	r/w	r/w	r/w	r/w	r/w
At Reset	0	0	0	0	0	0	0	0

Bit Definitions			
SENS1GAIN	BIT 0: S1_G2[0]	S1_G2[4:0}	Sensor 1 Stage 2 Gain (V/V)
	BIT 1: S1_G2[1]	00000	1.00
	BIT 2: S1_G2[2]	00001	1.10
	BIT 3: S1_G2[3]	00010	1.22
	BIT 4: S1_G2[4]	00011	1.35
		00100	1.50
		00101	1.67
		00110	1.85
		00111	2.05
		01000	2.28
		01001	2.53
		01010	2.81
		01011	3.11
		01100	3.46
		01101	3.86
		01110	4.26
		01111	4.76
		10000	5.26
		10001	5.86
		10010	6.46
		10011	7.16
		10100	7.96
		10101	8.86
		10110	9.86
		10111	10.96
		11000	12.16
		11001	13.46
		11010	14.96
		11011	16.56
		11100	18.36
		11101	20.46
		11110	22.56
		11111	25.06
	BIT 5: S1_G1[0]	S1_G1[2:0}	Sensor 1 Stage 1 Gain (V/V)
	BIT 6: S1_G1[1]	000	3.00
	BIT 7: S1_G1[2]	001	4.43
		010	6.80
		011	10.20
		100	14.57
		101	25.50

7.10.3.5 Sensor 2 Gain Register (SEN2GAIN)

SENS1GAIN				Not Bit Addressable				
ESFR:	0xA2	SEN2GAIN						
	BIT 7	BIT 6	BIT 5	BIT 4	BIT 3	BIT 2	BIT 1	BIT 0
	S2_G1[2]	S2_G1[1]	S2_G1[0]	S2_G1[4]	S2_G1[3]	S2_G1[2]	S2_G1[1]	S2_G1[0]
Access	r/w	r/w	r/w	r/w	r/w	r/w	r/w	r/w
At	0	0	0	0	0	0	0	0
Reset								

Bit Definitions			
SENS1GAIN	BIT 0: S2_G2[0]	S2_G2[4:0]	Sensor 2 Stage 2 Gain (V/V)
	BIT 1: S2_G2[1]	00000	1.00
	BIT 2: S2_G2[2]	00001	1.10
	BIT 3: S2_G2[3]	00010	1.22
	BIT 4: S2_G2[4]	00011	1.35
		00100	1.50
		00101	1.67
		00110	1.85
		00111	2.05
		01000	2.28
		01001	2.53
		01010	2.81
		01011	3.11
		01100	3.46
		01101	3.86
		01110	4.26
		01111	4.76
		10000	5.26
		10001	5.86
		10010	6.46
		10011	7.16
		10100	7.96
		10101	8.86
		10110	9.86
		10111	10.96
		11000	12.16
		11001	13.46
		11010	14.96
		11011	16.56
		11100	18.36
		11101	20.46
		11110	22.56
		11111	25.06
	BIT 5: S2_G1[0]	S2_G1[2:0]	Sensor 2 Stage 1 Gain (V/V)
	BIT 6: S2_G1[1]	000	3.00
	BIT 7: S2_G1[2]	001	4.43
		010	6.80
		011	10.20
		100	14.57

		101	25.50
--	--	-----	-------

7.10.3.6 Sensor 1 Offset Register (SEN1OFF1, SEN1OFF2)

SENSOR 1 OFFSET (SEN1OFF1, SEN1OFF2)				Not Bit Addressable					
ESFR:	0xA3	SEN1OFF1							
	BIT 7	BIT 6	BIT 5	BIT 4	BIT 3	BIT 2	BIT 1	BIT 0	
	S1_OS [7]	S1_OS [6]	S1_OS [5]	S1_OS [4]	S1_OS [3]	S1_OS [2]	S1_OS [1]	S1_OS [0]	
Access	r/w	r/w	r/w	r/w	r/w	r/w	r/w	r/w	
At Reset	0	0	0	0	0	0	0	0	

ESFR:	0xA4	SEN1OFF2							
	BIT 7	BIT 6	BIT 5	BIT 4	BIT 3	BIT 2	BIT 1	BIT 0	
	S1_OS[9]	S1_OS[8]	S1_OS[5]	S1_OS[4]	S1_OS[3]	S1_OS[2]	S1_OS[1]	S1_OS[0]	
Access	r/w	r/w	r/w	r/w	r/w	r/w	r/w	r/w	
At Reset	1	0	1	0	0	0	0	0	

Bit Definitions		
SEN1OFF1	BIT 0:S1_OS[0]	S1_OS: Sensor 1 Offset Compensation Setting
	BIT 1:S1_OS[1]	
	BIT 2:S1_OS[2]	
	BIT 3:S1_OS[3]	
	BIT 4:S1_OS[4]	
	BIT 5:S1_OS[5]	
	BIT 6:S1_OS[6]	
	BIT 7:S1_OS[7]	
SEN1OFF2	BIT 0:S1_TC[0]	S1_TC: Sensor 1 Offset TC Compensation Setting
	BIT 1:S1_TC[1]	
	BIT 2:S1_TC[2]	
	BIT 3:S1_TC[3]	
	BIT 4:S1_TC[4]	
	BIT 5:S1_TC[5]	
	BIT 6:S1_OS[8]	
	BIT 7:S1_OS[9]	

7.10.3.7 Sensor 2 Offset Register (SEN2OFF1, SEN2OFF2)

SENSOR 1 OFFSET (SEN1OFF1, SEN1OFF2)				Not Bit Addressable				
ESFR:	0xA5		SEN1OFF1					
	BIT 7	BIT 6	BIT 5	BIT 4	BIT 3	BIT 2	BIT 1	BIT 0
	S2_OS [7]	S2_OS [6]	S2_OS [5]	S2_OS [4]	S2_OS [3]	S2_OS [2]	S2_OS [1]	S2_OS [0]
Access	r/w	r/w	r/w	r/w	r/w	r/w	r/w	r/w
At Reset	0	0	0	0	0	0	0	0

ESFR:	0xA6		SEN1OFF2					
	BIT 7	BIT 6	BIT 5	BIT 4	BIT 3	BIT 2	BIT 1	BIT 0
	S2_OS[9]	S2_OS[8]	S2_OS[5]	S2_OS[4]	S2_OS[3]	S2_OS[2]	S2_OS[1]	S2_OS[0]
Access	r/w	r/w	r/w	r/w	r/w	r/w	r/w	r/w
At Reset	1	0	1	0	0	0	0	0

Bit Definitions		
SEN1OFF1	BIT 0:S2_OS[0]	S1_OS: Sensor 2 Offset Compensation Setting
	BIT 1:S2_OS[1]	
	BIT 2:S2_OS[2]	
	BIT 3:S2_OS[3]	
	BIT 4:S2_OS[4]	
	BIT 5:S2_OS[5]	
	BIT 6:S2_OS[6]	
	BIT 7:S2_OS[7]	
SEN1OFF2	BIT 0:S2_TC[0]	S1_TC: Sensor 2 Offset TC Compensation Setting
	BIT 1:S2_TC[1]	
	BIT 2:S2_TC[2]	
	BIT 3:S2_TC[3]	
	BIT 4:S2_TC[4]	
	BIT 5:S2_TC[5]	
	BIT 6:S2_OS[8]	
	BIT 7:S2_OS[9]	

7.10.3.8 Capacitive Sensor Settings Register (CAPSEN)

CAPACITIVE SENSOR REGISTER (CAPSEN)				Not Bit Addressable				
ESFR:	0xA7	CAPSEN						
	BIT 7	BIT 6	BIT 5	BIT 4	BIT 3	BIT 2	BIT 1	BIT 0
	SEN_TYP	CI[2]	CI[1]	CI[0]	CV[1]	CV[0]	CR[1]	CR[0]
Access	r/w	r/w	r/w	r/w	r/w	r/w	r/w	r/w
At Reset	1	0	0	0	0	0	0	0

Bit Definitions					
CAPSEN	BIT 0:CR[0]	CR[1]		CR[0]	Capacitive Sensor Transimpedance (kΩ)
	BIT 1:CR[1]	0		0	78
		0		1	156
		1		0	312
	1		1		625
	BIT 2:CV[0]	CV[1]		CV[0]	Capacitive Sensor Drive Threshold Voltage (mV)
	BIT 3:CV[1]	0		0	100
		0		1	300
		1		0	500
	1		1		700
	BIT 4:CI[0]	CI[2]	CI[1]	CI[0]	Capacitive Sensor Drive Current (μA)
	BIT 5:CI[1]	0	0	0	5
	BIT 6:CI[2]	0	0	1	7.5
		0	1	0	10
		0	1	1	12.5
		1	0	0	15
		1	0	1	17.5
		1	1	0	20
	1	1	1	22	
BIT 7:SEN_TYP	0: Capacitive Front End 1: Resistive Bridge Front End				

7.10.3.9 Sensor Control (SENCTRL)

SENSOR CONTROL (SENCTRL)				Not Bit Addressable				
ESFR:	0xA9	SENCTRL						
	BIT 7	BIT 6	BIT 5	BIT 4	BIT 3	BIT 2	BIT 1	BIT 0
	SEN_CHNL	S1_INV	S2_INV	ADC_BUF	TEMP_SEN	XTAL_EN	VBRG_EN	–
Access		r/w	r/w	r/w	r/w	r/w	r/w	r/w
At	0	0	0	1	0	0	1	0

Bit Definitions		
SENCTRL	BIT 0:	
	BIT 1: VBRG_EN	VBRG Enable 0: Disabled 1: Enabled
	BIT 2: XTAL_EN	0: Internal Oscillator 1: External Crystal
	BIT 3: TEMP_SEN	0: Internal Temperature Sensor 1: External Temperature Sensor
	BIT 4: ADC_BUF	0: ADC Buffer Output is not level-shifted 1: ADC Buffer Output is level-shifted
	BIT 5: S2_INV	S2 Sign Bit 1: S2 signal chain is inverted 0: S2 signal chain is not inverted
	BIT 6: S1_INV	S1 Sign Bit 1: S1 signal chain is inverted 0: S1 signal chain is not inverted
	BIT 7: SEN_CHNL	0: S1 Channel 1: S2 Channel

7.10.3.10 GPIO Strong Output Drive Mode (GPIO_STRG)

GPIO Strong Output Drive Mode (GPIO_STRG)			Not Bit Addressable					
ESFR:	0xAA	GPIO_STRG						
	BIT 7	BIT 6	BIT 5	BIT 4	BIT 3	BIT 2	BIT 1	BIT 0
	ST_TX	-	ST_GPO5	ST_GPO4	ST_GPO3	ST_GPO2	ST_GPO1	-
Access	r/w	r/w	r/w	r/w	r/w	r/w	r/w	r/w
At Reset	0	0	0	0	0	0	0	0

Bit Definitions		
SENCTRL	BIT 0:	-
	BIT 1: ST_GPO1	0: Normal 8051W Mode 1: Strong Output Mode
	BIT 2: ST_GPO2	0: Normal 8051W Mode 1: Strong Output Mode
	BIT 3: ST_GPO3	0: Normal 8051W Mode 1: Strong Output Mode
	BIT 4: ST_GPO4	0: Normal 8051W Mode 1: Strong Output Mode
	BIT 5: ST_GPO5	0: Normal 8051W Mode 1: Strong Output Mode
	BIT 6: -	-
	BIT 6: ST_TX	0: Normal 8051W Mode 1: Strong Output Mode

7.10.3.11 CTOV clock Count Register (CTOV_CLK_CNT)

CLOCK COUNT REGISTER (CTOV_CLK_CNT)				Not Bit Addressable				
ESFR:	0xAB		CTOV_CLK_CNT					
	BIT 7	BIT 6	BIT 5	BIT 4	BIT 3	BIT 2	BIT 1	BIT 0
	CLKCNT[7]	CLKCNT[6]	CLKCNT[5]	CLKCNT[4]	CLKCNT[3]	CLKCNT[2]	CLKCNT[1]	CLKCNT[0]
Access	r/w	r/w	r/w	r/w	r/w	r/w	r/w	r/w
At Reset	0	0	0	0	0	0	0	0

The clock count register has a resolution of 10MHz.

7.10.3.12 ADC Decimator Output (ADCMSB, ADCLSB)

ADC Decimator Output				Not Bit Addressable				
ESFR:	0xB1		ADCMSB					
	BIT 7	BIT 6	BIT 5	BIT 4	BIT 3	BIT 2	BIT 1	BIT 0
	ADC[15]	ADC[14]	ADC[13]	ADC[12]	ADC[11]	ADC[10]	ADC[9]	ADC[8]
Access	r	r	r	r	r	r	r	r
At Reset	0	0	0	0	0	0	0	0

ESFR:	0xB2		ADCLSB					
	BIT 7	BIT 6	BIT 5	BIT 4	BIT 3	BIT 2	BIT 1	BIT 0
	ADC[7]	ADC[6]	ADC[5]	ADC[4]	ADC[3]	ADC[2]	ADC[1]	ADC[0]
Access	r/w	r/w	r/w	r/w	r/w	r/w	r/w	r/w
At Reset	0	0	0	0	0	0	0	0

7.10.3.13 Load ADC Decimator Shadow Register (LD_DEC)

LOAD DECIMATOR SHADOW REGISTER (LD_DEC)				Not Bit Addressable				
ESFR:	0xB3		LD_DEC					
	BIT 7	BIT 6	BIT 5	BIT 4	BIT 3	BIT 2	BIT 1	BIT 0
	–	–	–	–	–	LD_SADC1	LD_SADC2	LD_TADC
Access	–	–	–	–	–	w	w	w
At Reset	0	0	0	0	0	0	0	0

Bit Definitions		
SENCTRL	BIT 0: LD_TADC	0: No Action 1: Load the output of the Temperature Decimator to ADC Decimator Output Register
	BIT 1: LD_SADC2	0: No Action 1: Load the output of the Stage 2 Decimator to ADC Decimator Output Register
	BIT 2: LD_SADC1	0: No Action 1: Load the output of the Stage 1 Decimator to ADC Decimator Output Register
	BIT 3: –	–
	BIT 4: –	–
	BIT 5: –	–
	BIT 6: –	–
	BIT 7: –	–

7.10.3.14 DAC 1 Register (DAC1MSB, DAC1LSB)

DAC1 Register (DAC1MSB, DAC1LSB)				Not Bit Addressable				
ESFR:	0xB7		DAC1MSB					
	BIT 7	BIT 6	BIT 5	BIT 4	BIT 3	BIT 2	BIT 1	BIT 0
	–	–	–	–	DAC1[11]	DAC1[10]	DAC1[9]	DAC1[8]
Access	r/w	r/w	r/w	r/w	r/w	r/w	w	R
At Reset	0	0	0	0	0	0	0	0

ESFR:	0xB9		DAC1LSB					
	BIT 7	BIT 6	BIT 5	BIT 4	BIT 3	BIT 2	BIT 1	BIT 0
	DAC1[7]	DAC1[6]	DAC1[5]	DAC1[4]	DAC1[3]	DAC1[2]	DAC1[1]	DAC1[0]
Access	r/w	r/w	r/w	r/w	r/w	r/w	w	R
At Reset	0	0	0	0	0	0	0	0

7.10.3.15 DAC 2 Register (DAC2MSB, DAC2LSB)

DAC2 (DAC2MSB, DAC2LSB)				Not Bit Addressable				
ESFR:	0xBA		DAC2MSB					
	BIT 7	BIT 6	BIT 5	BIT 4	BIT 3	BIT 2	BIT 1	BIT 0
	–	–	–	–	DAC2[11]	DAC2[10]	DAC2[9]	DAC2[8]
Access	r/w	r/w	r/w	r/w	r/w	r/w	w	r/w
At Reset	0	0	0	0	0	0	0	0

ESFR:	0xBB		DAC2LSB					
	BIT 7	BIT 6	BIT 5	BIT 4	BIT 3	BIT 2	BIT 1	BIT 0
	DAC2[7]	DAC2[6]	DAC2[5]	DAC2[4]	DAC2[3]	DAC2[2]	DAC2[1]	DAC2[0]
Access	r/w	r/w	r/w	r/w	r/w	r/w	r/w	r/w
At Reset	0	0	0	0	0	0	0	0

7.10.3.16 Decimator and Low Power Control Register (DECCTRL)

DECIMATOR CONTROL (DECCTRL)				Not Bit Addressable				
ESFR:	0xBC		DECCTRL					
	BIT 7	BIT 6	BIT 5	BIT 4	BIT 3	BIT 2	BIT 1	BIT 0
	DIS_R1M	DIS_R2M	DAC2_EN	AFE_EN	–	–	OSR[1]	OSR[0]
Access	r	r	r/w	r/w	r	r	r/w	r/w
At	0	0	1	1	0	0	0	0

Bit Definitions		
DECCTRL	BIT 0:OSR[0]	2nd Stage Decimator OSR Control
	BIT 1:OSR[1]	00: 2 01: 4 10: 8 11:: N/A
	BIT 2: -	–
	BIT 3: -	–
	BIT 4:AFE_EN	0: AFE is disabled 1: AFE is enabled
	BIT 5:-DAC2_EN	0: DAC2 is disabled 1: DAC2 is enabled
	BIT 6:-	–
	BIT 7:-	–

7.10.3.17 Input Capture/Output Compare Control Register (IC_OC_CTRL)

IC_OC_CTRL				Not Bit Addressable				
ESFR:	0xC0	IC_OC_CTRL						
	BIT 7	BIT 6	BIT 5	BIT 4	BIT 3	BIT 2	BIT 1	BIT 0
	–	–	IC_OC_TIM_LAT	OC2_LVL	OC1_LVL	IC2_EDGE	IC1_EDGE	10_20_MHZ
Access	r/w	r/w	r/w	r/w	r/w	r/w	r/w	r/w
At	0	0	0	0	0	0	0	0

Bit Definitions			
BIT 0:10_20_MHZ	0: Free Running Timer Resolution is 20MHz 1: Free Running Timer Resolution is 10MHz		
BIT 1:IC1_EDGE	0: Capture Falling Edge on Input Capture 1 1: Capture Rising Edge on Input Capture 1		
BIT 2:IC2_EDGE	0: Capture Falling Edge on Input Capture 2 1: Capture Rising Edge on Input Capture 2		
BIT 3:OC1_LVL	0: OC_1 is set to 0 upon match 1: OC_1 is set to 1 upon match		
BIT 4:OC2_LVL	0: OC_2 is set to 0 upon match 1: OC_2 is set to 1 upon match		
BIT 5: IC_OC_TIM_LAT	0: No Action 1: Latches the free-running timer values into the free running timer shadow register		
BIT 6: DIS_R2M	AFE Pull-Down Resistor Value		
BIT 7: DIS_R1M	DIS_R1M	DIS_R2M	Pull-down Resistor Value (MΩ)
	0	0	4
	0	1	2
	1	0	3
	1	1	1

7.10.3.18 Input Capture 1 Register (IC1MSB, IC1LSB)

INPUT CAPTURE 1 (IC1MSB, IC1LSB)				Not Bit Addressable				
ESFR:	0xC1		IC1MSB					
	BIT 7	BIT 6	BIT 5	BIT 4	BIT 3	BIT 2	BIT 1	BIT 0
	IC1[15]	IC1[14]	IC1[13]	IC1[12]	IC1[11]	IC1[10]	IC1[9]	IC1[8]
Access	r	r	r	r	r	r	r	r
At Reset	0	0	0	0	0	0	0	0

ESFR:	0xC2		IC1LSB					
	BIT 7	BIT 6	BIT 5	BIT 4	BIT 3	BIT 2	BIT 1	BIT 0
	IC1[7]	IC1[6]	IC1[5]	IC1[4]	IC1[3]	IC1[2]	IC1[1]	IC1[0]
Access	r	r	r	r	r	r	r	r
At Reset	0	0	0	0	0	0	0	0

7.10.3.19 Input Capture 2 Register (IC2MSB, IC2LSB)

INPUT CAPTURE 1 (IC2MSB, IC2LSB)				Not Bit Addressable				
ESFR:	0xC3		IC2MSB					
	BIT 7	BIT 6	BIT 5	BIT 4	BIT 3	BIT 2	BIT 1	BIT 0
	IC2[15]	IC2[14]	IC2[13]	IC2[12]	IC2[11]	IC2[10]	IC2[9]	IC2[8]
Access	r	r	r	r	r	r	r	r
At Reset	0	0	0	0	0	0	0	0

ESFR:	0xC4		IC2LSB					
	BIT 7	BIT 6	BIT 5	BIT 4	BIT 3	BIT 2	BIT 1	BIT 0
	IC2[7]	IC2[6]	IC2[5]	IC2[4]	IC2[3]	IC2[2]	IC2[1]	IC2[0]
Access	r	r	r	r	r	r	r	r
At Reset	0	0	0	0	0	0	0	0

7.10.3.20 Output Compare 1 Register (OC1MSB, OC1LSB)

OUTPUT COMPARE 1 (OC1MSB, OC1LSB)				Not Bit Addressable				
ESFR:	0xC5		OC1MSB					
	BIT 7	BIT 6	BIT 5	BIT 4	BIT 3	BIT 2	BIT 1	BIT 0
	OC1[15]	OC1[14]	OC1[13]	OC1[12]	OC1[11]	OC1[10]	OC1[9]	OC1[8]
Access	r/w	r/w	r/w	r/w	r/w	r/w	r/w	r/w
At Reset	0	0	0	0	0	0	0	0

ESFR:	0xC6		OC1LSB					
	BIT 7	BIT 6	BIT 5	BIT 4	BIT 3	BIT 2	BIT 1	BIT 0
	OC1[7]	OC1[6]	OC1[5]	OC1[4]	OC1[3]	OC1[2]	OC1[1]	OC1[0]
Access	r/w	r/w	r/w	r/w	r/w	r/w	r/w	r/w
At Reset	0	0	0	0	0	0	0	0

7.10.3.21 Input Capture/Output Compare GPIO Register (IC_OC_GPIO)

IC_OC_GPIO				Not Bit Addressable				
ESFR:	0xC7	IC_OC_GPIO						
	BIT 7	BIT 6	BIT 5	BIT 4	BIT 3	BIT 2	BIT 1	BIT 0
	–	–	–	–	OC2_ACT	OC1_ACT	IC2_ACT	IC1_ACT
Access	r/w	r/w	r/w	r/w	r/w	r/w	r/w	r/w
At	0	0	0	0	0	0	0	0

Bit Definitions		
BIT 0:IC1_ACT		0: GPIO_1 is not configured for IC_1 1: GPIO_1 is configured for IC_1
BIT 1:IC2_ACT		0: GPIO_2 is not configured for IC_2 1: GPIO_2 is configured for IC_2
BIT 2:OC1_ACT		0: GPIO_3 is not configured for OC_1 1: GPIO_3 is configured for OC_1
BIT 3:OC2_ACT		0: GPIO_4 is not configured for OC_2 1: GPIO_4 is configured for OC_2
BIT 4:-		–
BIT 5:-		–
BIT 6:-		–
BIT 7:-		–

7.10.3.22 Output Compare 2 Register (OC2MSB, OC2LSB)

OUTPUT COMPARE 1 (OC2MSB, OC2LSB)				Not Bit Addressable				
ESFR:	0xC9		OC2MSB					
	BIT 7	BIT 6	BIT 5	BIT 4	BIT 3	BIT 2	BIT 1	BIT 0
	OC2[15]	OC2[14]	OC2[13]	OC2[12]	OC2[11]	OC2[10]	OC2[9]	OC2[8]
Access	r/w	r/w	r/w	r/w	r/w	r/w	r/w	r/w
At Reset	0	0	0	0	0	0	0	0

ESFR:	0xCA		OC2LSB					
	BIT 7	BIT 6	BIT 5	BIT 4	BIT 3	BIT 2	BIT 1	BIT 0
	OC2[7]	OC2[6]	OC2[5]	OC2[4]	OC2[3]	OC2[2]	OC2[1]	OC2[0]
Access	r/w	r/w	r/w	r/w	r/w	r/w	r/w	r/w
At Reset	0	0	0	0	0	0	0	0

7.10.3.23 Free Running Timer Shadow Register (FRTMSB, FRTL SB)

FREE RUNNING TIMER 1 (FRTMSB, FRTL SB)				Not Bit Addressable				
ESFR:	0xCB		FRTMSB					
	BIT 7	BIT 6	BIT 5	BIT 4	BIT 3	BIT 2	BIT 1	BIT 0
	FRT[15]	FRT[14]	FRT[13]	FRT[12]	FRT[11]	FRT[10]	FRT[9]	FRT[8]
Access	r	r	r	r	r	r	r	r
At Reset	0	0	0	0	0	0	0	0

ESFR:	0xCC		FRTL SB					
	BIT 7	BIT 6	BIT 5	BIT 4	BIT 3	BIT 2	BIT 1	BIT 0
	FRT[7]	FRT[6]	FRT[5]	FRT[4]	FRT[3]	FRT[2]	FRT[1]	FRT[0]
Access	r	r	r	r	r	r	r	r
At Reset	0	0	0	0	0	0	0	0

7.10.3.24 Communication Data Buffer (COMBUF)

COMM DATA BUFFER (COMBUF)				Not Bit Addressable				
ESFR:	0xD3		COMBUF					
	BIT 7	BIT 6	BIT 5	BIT 4	BIT 3	BIT 2	BIT 1	BIT 0
	COMBUF[7]	COMBUF[6]	COMBUF[5]	COMBUF[4]	COMBUF[3]	COMBUF[2]	COMBUF[1]	COMBUF[0]
Access	r/w	r/w	r/w	r/w	r/w	r/w	r/w	r/w
At	0	0	0	0	0	0	0	0

7.10.3.25 Digital Interface Control Register (DI_CTRL)

DI CONTROL REGISTER (DI_CTRL)				Not Bit Addressable				
ESFR:	0xD4		DI_CTRL					
	BIT 7	BIT 6	BIT 5	BIT 4	BIT 3	BIT 2	BIT 1	BIT 0
	–	–	–	–	OWI_DEGLITCH_SEL	OWI_XCR_EN	DI_CTRL[1]	DI_CTRL[0]
Access		R	r	r	r/w	r/w	r/w	r/w
At	0	0	0	0	0	0	0	0

Bit Definitions		
BIT 0:DI_CTRL[0]		00: SPI/DAC1 are active 01: I2C/DAC1 are active
BIT 1: DI_CTRL[1]		10: OWI is active 11: SPI/DAC1 is active
BIT 2:OWI_XCR_EN		0: Disable OWI Transceiver – DAC1 is connected to VOUT1/OWI 1: Enable OWI Transceiver – OWI Transceiver is connected to VOUT1/OWI
BIT 3: OWI_DEGLITCH_SEL		0: OWI activation deglitch filters are set to 1ms 1: OWI activation deglitch filters are set to 10ms
BIT 4: -		–
BIT 5: -		–
BIT 6: -		–
BIT 7:-		–

7.10.3.26 Enable Control Register (EN_CTRL)

ENABLE REGISTER (EN_CTRL)				Not Bit Addressable				
ESFR:	0xD5		EN_CTRL					
	BIT 7	BIT 6	BIT 5	BIT 4	BIT 3	BIT 2	BIT 1	BIT 0
	-	-	-	INT_CAPS_EN	LB_EN	CTOV_CLK_MON_EN	MAIN_OSC_WD_EN	CPU_WD_EN
Access		r/w	r/w	r/w	r/w	r/w	r/w	r/w
At	0	0	0	0	0	0	0	0

Bit Definitions		
BIT 0:CPU_WD_EN		0: Software watchdog is disabled 1: Software watchdog is enabled
BIT 1: MAIN_OSC_WD_EN		0: Internal Oscillator watchdog is disabled 1: Internal Oscillator watchdog is enabled
BIT 2:CTOV_CLK_MON_EN		0: Disable Cap Sensor Clock High/Low flag operation 1: Enable Cap Sensor Clock High/Low flag operation
BIT 3: LB_EN		0: DAC loopback is disabled 1: DAC Loopback is enabled in both resistive and capacitive modes. The AFE is switched to resistive bridge mode
BIT 4: INT_CAPS_EN		0: External Sensor Caps are connected to Capacitive AFE 1: Internal Test Caps are connected to Capacitive AFE
BIT 5: -		–
BIT 6: -		–
BIT 7:-		–

7.10.3.27 Enable Control Register (EN_CTRL2)

ENABLE REGISTER (EN_CTRL2)				Not Bit Addressable				
ESFR:	0xD6		EN_CTRL2					
	BIT 7	BIT 6	BIT 5	BIT 4	BIT 3	BIT 2	BIT 1	BIT 0
	-	-	-	-	-	EN_IRAM_MBIST	EN_DI_IF_CLK	EN_EEPROM_CTRL_CLK
Access		r/w	r/w	r/w	r/w	r/w	r/w	r/w
At	0	0	0	0	0	0	0	0

Bit Definitions		
BIT 0: EN_EEPROM_CTRL_CLK		0: Disable clock to the EEPROM controller. All EEPROM access is disabled 1: Enable clock to the EEPROM Controller
BIT 1: EN_DI_IF_CLK		0: Disable clock to the Digital Interface controller. No digital interface can be used 1: Enable clock to the Digital Interface Controller Special note: This bit will automatically be set to '1' if an OWI activation interrupt occurs or if NCS (SPI chip select = '0' for at least 5 10MHz clock cycles. Noise on the NCS pin can cause the unintentional activation of the Digital Interface clock
BIT 2: EN_IRAM_MBIST		0: Disable IRAM MBIST 1: Enable IRAM MBIST. 8051W will not have access to RAM
BIT 3: -		-
BIT 4: -		-
BIT 5: -		-
BIT 6: -		-
BIT 7:-		-

7.10.3.28 RAM MBIST Status Register (RAM_MBIST_ST)

ENABLE REGISTER (EN_CTRL2)				Not Bit Addressable				
ESFR:	0xD5		EN_CTRL2					
	BIT 7	BIT 6	BIT 5	BIT 4	BIT 3	BIT 2	BIT 1	BIT 0
	-	-	-	-	-	-	IRAM_MBIST_FAIL	IRAM_MBIST_DONE
Access		r/w	r/w	r/w	r/w	r/w	r	r
At	0	0	0	0	0	0	0	0

Bit Definitions		
BIT 0: IRAM_MBIST_DONE		0: RAM MBIST is not complete 1: RAM MBIST complete Note: This bit is valid only after IRAM_MBIST_EN has been set to 1
BIT 1: IRAM_MBIST_FAIL		0: RAM MBIST had no failures after completion 1: RAM MBIST experienced a failure Note: This bit is valid only after IRAM_MBIST_DONE flag is set 1
BIT 2: -		-
BIT 3: -		-
BIT 4: -		-
BIT 5: -		-
BIT 6: -		-
BIT 7:-		-

7.10.3.29 EEPROM Status Register (EE_STATUS)

EEPROM STATUS (EE_STATUS)				Not Bit Addressable					
ESFR:	0xE1		EE_STATUS						
	BIT 7	BIT 6	BIT 5	BIT 4	BIT 3	BIT 2	BIT 1	BIT 0	
	TRIM_ERR	CRC_ERR	EEPROM_GOOD	EE_READ_IN_PROG	EE_PROG_IN_PROG	EE_BNK[2]	EE_BNK[1]	EE_BNK[0]	
Access		r	r	r	r	r	r	r	
At	0	0	0	0	0	0	0	0	

Bit Definitions		
BIT 0:EE_BNK[0]		000: Bank 0 has been selected 001: Bank 1 has been selected
BIT 1:EE_BNK[1]		010: Bank 2 has been selected 011: Bank 3 has been selected
BIT 2:EE_BNK[2]		100: Bank 4 has been selected 101: Bank 5 has been selected 110: D/C 111 D/C
BIT 3: EE_PROG_IN_PROG		0: Idle 1: EEPROM programming in progress
BIT 4: EE_READ_IN_PROG		0: Idle 1: EEPROM data transfer to cache in progress
BIT 5: EEPROM_GOOD		0: EEPROM programming not good 1: EEPROM programming good
BIT 6:CRC_ERR		0: EEPROM CRC is good 1: EEPROM CRC is in error
BIT 7:TRIM_ERR		0: Internal TRIM Value is good 1: Internal TRIM Value is corrupted

7.10.3.30 EEPROM Control Register (EE_CTRL)

EEPROM CONTROL REGISTER (EE_CTRL)				Not Bit Addressable					
ESFR:	0xE2		EE_CTRL						
	BIT 7	BIT 6	BIT 5	BIT 4	BIT 3	BIT 2	BIT 1	BIT 0	
	–	–	–	–	–	–	–	MICRO_EEPROM	
Access		r/w	r/w	r/w	r/w	r/w	r/w	r/w	
At	0	0	0	0	0	0	0	0	

Bit Definitions		
BIT 0:MICRO_EEPROM		0: No Action 1: Program Bank 0 of EEPROM
BIT 1: -		–
BIT 2: -		–
BIT 3: -		–
BIT 4: -		–
BIT 5:-		–
BIT 6: -		–
BIT 7: -		–

7.10.4 Test Registers

The Test Registers are special registers that are accessible only via Digital Interface (SPI, OWI, I2C). Note that these registers are not mapped into the 8051W address space and hence are not accessible to the 8051W microprocessor.

Upon Power-up the Digital interface will only have access to the test register space. For the Digital interface (SPI, I2C, OWI) to gain access to the other Memory spaces, it is necessary to set the IF_SEL bit in the Micro/Interface Control register (address 0xD0). After setting this bit to '1' the digital interface will have access to all of the memory space while the 8051W will be denied access to all memory spaces. Since the 8051W will be denied access to any memory including the program memory space, it is recommended for the user to put the 8051W in reset state by writing a '1' to MICRO_RESET bit in the Micro/Interface Control register before IF_SEL bit is set to '1'.

ADDRESS (hex)	D7	D6	D5	D4	D3	D2	D1	D0	R/W	POWER UP	DESCRIPTION (PROGRAMMABLE REGS)
03	–	–	–	–	CLR_OWI_STAT	TOP_ACT	TON_ACT	TIP_ACT	R/W	0x00	TESTMUX_ACT
04	COMBUF[7]	COMBUF[6]	COMBUF[5]	COMBUF[4]	COMBUF[3]	COMBUF[2]	COMBUF[1]	COMBUF[0]	R/W	0x00	COMBUF_T
05	–	–	–	–	–	–	–	COMM_DATA_RDY	R/W	0x00	COMBUF_R
06	–	–	AMUX_0[5]	AMUX_0[4]	AMUX_0[3]	AMUX_0[2]	AMUX_0[1]	AMUX_0[0]	R/W	0xx0	AMUX_O
07	–	–	–	DMUX_O[4]	DMUX_O[3]	DMUX_O[2]	DMUX_O[1]	DMUX_O[0]	R/W	0xx0	DMUX_O
08	–	–	AMUX_I[5]	AMUX_I[4]	AMUX_I[3]	AMUX_I[2]	AMUX_I[1]	AMUX_I[0]	R/W	0x00	AMUX_I
09	–	–	–	–	DMUX_I[3]	DMUX_I[2]	DMUX_I[1]	DMUX_I[0]	R/W	0x00	DMUX_I
0D	–	–	EE_BANK_RELOAD	IGN_PROG_TIMER	DI_EEPROG	EE_BANK_SEL[2]	EE_BANK_SEL[1]	EE_BANK_SEL[0]	R/W	0x00	EEPROM_A
0E	–	–	–	–	–	–	MICRO_RESET	IF_SEL	R/W	0x00	MICRO_IF_SELECT
14	OWI_ERR_1[7]	OWI_ERR_1[6]	OWI_ERR_1[5]	OWI_ERR_1[4]	OWI_ERR_1[3]	OWI_ERR_1[2]	OWI_ERR_1[1]	OWI_ERR_1[0]	R/W	0x00	OWI_ERR_1
15	-	-	-	-	-	-	OWI_ERR_2[1]	OWI_ERR_2[0]	R/W	0x00	OWI_ERR_2

7.10.4.1 Test MUX Activation Register (TESTMUX_ACT)

Test MUX Activation Register (TESTMUX_ACT)				Not Bit Addressable				
TEST:	0x03							
	BIT 7	BIT 6	BIT 5	BIT 4	BIT 3	BIT 2	BIT 1	BIT 0
	–	–	–	–	CLR_OWI_STAT	TOP_ACT	TON_ACT	TIP_ACT
Access	r/w	r/w	r/w	r/w	r/w	r/w	r/w	r/w
At Reset	0	0	0	0	0	0	0	0

Bit Definitions		
BIT 0: TIP_ACT		0: No Action 1: Activates GPIO_2 for Test Digital Input P
BIT 1: TON_ACT		0: No Action 1: Activates GPIO_4 for Test Digital Output N
BIT 2: TOP_ACT		0: No Action 1: Activates GPIO_3 for Test Digital Output P
BIT 3: CLR_OWI_STAT		0: OWI Error bits not cleared 1: OWI Error bits are cleared
BIT 4: -		–
BIT 5: -		–
BIT 6: -		–
BIT 7: -		–

NOTE

The TEST MUX register is only meant to be used for debugging purposes. The performance of this test mux registers is not characterized.

7.10.4.2 Communication Data Buffer (COMBUF_T)

Communication Data Buffer Test (COMBUF_T)				Not Bit Addressable				
TEST:	0x04							
	BIT 7	BIT 6	BIT 5	BIT 4	BIT 3	BIT 2	BIT 1	BIT 0
	COMBUF[7]	COMBUF[6]	COMBUF[5]	COMBUF[4]	COMBUF[3]	COMBUF[2]	COMBUF[1]	COMBUF[0]
Access	r/w	r/w	r/w	r/w	r/w	r/w	r/w	r/w
At Reset	0	0	0	0	0	0	0	0

7.10.4.3 Communication Data Buffer Ready (COMBUF_R)

Communication Data Buffer Ready (COMBUF_R)				Not Bit Addressable				
TEST:	0x05							
	BIT 7	BIT 6	BIT 5	BIT 4	BIT 3	BIT 2	BIT 1	BIT 0
	–	–	–	–	–	–	–	COMM_DATA_RDY
Access	r/w	r/w	r/w	r/w	r/w	r/w	r/w	r/w
At Reset	0	0	0	0	0	0	0	0

Bit Definitions		
	BIT 0: COMM_DATA_RDY	0: Communication Data Not available 1: Microprocessor had loaded data into the COMBUF ESFR
	BIT 1: TON_ACT	–
	BIT 2: TOP_ACT	–
	BIT 3: -	–
	BIT 4: -	–
	BIT 5: -	–
	BIT 6: -	–
	BIT 7: -	–

7.10.4.4 Analog Test MUX Out Register (AMUX_O)

Analog Test MUX Out Register (AMUX_O)				Not Bit Addressable				
TEST:	0x06							
	BIT 7	BIT 6	BIT 5	BIT 4	BIT 3	BIT 2	BIT 1	BIT 0
	–	–	AMUX_0[5]	AMUX_0[4]	AMUX_0[3]	AMUX_0[2]	AMUX_0[1]	AMUX_0[0]
Access	r/w	r/w	r/w	r/w	r/w	r/w	r/w	r/w
At Reset	0	0	0	0	0	0	0	0

AMUX_O[5:0] (Hex)	TOP Output	TON Output	Voltage Divider	Description
00	GND	GND	-	30K Resistor to Ground
01	TOUT_STAGE1p	TOUT_STAGE1n		Stage 1 Output
02	TOUT_STAGE2p	TOUT_STAGE2n		Stage 2 Output
03	TOUT_ADC_BUFp	TADC_BUFn		ADC Buffer Output
04	TOUT_CTOV_OUTp	TOUT_CTOV_OUTn		CtoV Output Prior to Buffer
05	TOUT_CTOV_BUFp	TOUT_CTOV_BUFn		CtoV Output After Buffer
06	TOUT_OSCMP_OUTp	TOUT_OSCMP_OUTn		Offset Compensation DAC before (A1)/E Amp
07	TOUT_OSCMP_AMPp	TOUT_OSCMP_AMPn		Offset Compensation Output delivered to Stage 2 Input
08	TOUT_V2P475	TOUT_V0P825		Internal 2.475V and 0.825V references
09	TOUT_VBG3V	TOUT_VPTAT		Internal BG ZTC voltage (buffered) and PTAT signal used by temp sensor and offset compensation (un-buffered)
0A	TOUT_VBG5V	GND (Spare)		5V ZTC reference voltage (buffered) used as a ref by AVDD & DVDD
0B	TOUT_V1P65V	GND (Spare)		Output the internal common mode reference voltage
0C	TOUT_TEMP_ADC_IN	GND (Spare)		Output of the buffer driving the temp ADC
0D	TOUT_VCCINT	GND (Spare)	0.2*VCC_INT	Internal protected 5V supply
0E	TOUT_OTP_REG2V	GND (Spare)		OTP 2V regulator voltage
0F	TOUT_EEPROM_VPROG	GND (Spare)	0.2*VEEPROM_P	EEPROM program voltage
10	TOUT_EEPROM_VSHIFT	GND (Spare)		EEPROM Vshift voltage
11	TOUT_EEPROM_VT	GND (Spare)		EEPROM VT voltage

NOTE

The TEST MUX register is only meant to be used for debugging purposes. The performance of this test mux registers is not characterized.

7.10.4.5 Digital Test MUX Out Register (DMUX_O)

Digital Test MUX Out Register (DMUX_O)				Not Bit Addressable				
TEST:	0x07							
	BIT 7	BIT 6	BIT 5	BIT 4	BIT 3	BIT 2	BIT 1	BIT 0
	–	–	–	DMUX_O[4]	DMUX_O[3]	DMUX_O[2]	DMUX_O[1]	DMUX_O[0]
Access	r/w	r/w	r/w	r/w	r/w	r/w	r/w	r/w
At Reset	0	0	0	0	0	0	0	0

DMUX_O[4:0] (Hex)	TOP_D (GPIO3)	TON_D (GPIO4)	Remark
00	ZERO	ZERO	Ground
01	PSMON[0]	PSMON[1]	PSMON Flags
02	PSMON[2]	PSMON[3]	PSMON Flags
03	PSMON[4]	PSMON[5]	PSMON Flags
04	PSMON[6]	PSMON[7]	PSMON Flags
05	PSMON[8]	PSMON[9]	PSMON Flags
06	PSMON[10]	PSMON[11]	PSMON Flags
07	AFEDIAG[0]	AFEDIAG[1]	AFEDIAG Flags
08	AFEDIAG[2]	AFEDIAG[3]	AFEDIAG Flags
09	OWI_5P4_COMP_IN	OWI_6P8_COMP_IN	Low and High comparator outputs used by OWI Activation circuit
0A	OSC_5M	OSC_200K	5MHz Internal oscillator and 200kHz Watchdog Oscillator
0B	OSC_XTAL	CLK_EE_2M	Crystal Oscillator and EEPROM Charge Pump Clk
0C	CLK_ADC_1M	CLK_TADC_128K	Pressure ADC Clock and Temperature ADC Clock
0D	CHOP_CLK_700K	CTOV_CLK	First Stage Chopper Clock, Capacitive AFE Clock
0E	SDM_PWM	SDM_ERR	PWM and ERR output from Pressure SDM
0F	SDM_TEMP	CIRAM_MBIST_RETENTION	PWM from Temperature SDM, CIRAM MBIST Retention Stop
10	LOAD_DS1	LOAD_DS2	Sensor decimator downsample pulses
11	LOAD_DS_TEMP	XINTR_SRC[5]	Temperature decimator downsample pulse, External Interrupt
12	XINTR_SRC[7]	XINTR_SRC[8]	External Interrupt
13	XINTR_SRC[9]	XINTR_SRC[10]	External Interrupt
14	XINTR_SRC[11]	XINTR_SRC[12]	External Interrupt

7.10.4.6 Analog Test MUX In Register (AMUX_I)

Analog Test MUX In Register (AMUX_I)				Not Bit Addressable				
TEST:	0x08							
	BIT 7	BIT 6	BIT 5	BIT 4	BIT 3	BIT 2	BIT 1	BIT 0
	–	–	–	AMUX_I[4]	AMUX_I[3]	AMUX_I[2]	AMUX_I[1]	AMUX_I[0]
Access	r/w	r/w	r/w	r/w	r/w	r/w	r/w	r/w
At Reset	0	0	0	0	0	0	0	0

AMUX_I[4:0] (Hex)	TIP	TIN	Remark
00	GND	GND	30K Resistor to Ground
01	TIN_STAGE2p	TIN_STAGE2N	Input to Stage 2 Amp
02	TIN_ADC_BUFp	TIN_ADC_BUFn	Input to ADC Buffer
03	TIN_ADCp	TIN_ADCn	Input to Pressure SDM
04	TIN_CTOV_AMPp	TIN_CTOV_AMPn	Input to CTOV Trans-Z configured as voltage amplifier in test mode
05	TIN_CTOV_OUTp	TIN_CTOV_OUTn	Input to output buffer in the CTOV AFE
06	TIN_OSCMP_AMPp	TIN_OSCMP_AMPn	Input to the voltage amplifier in the offset compensation circuit
07	TIN_V2P475	TIN_V0P825	Set the internal 2.475V and 0.825V references
08	TIN_DAC_BUFF1	TIN_DAC_BUFF2	Input to the DAC Buffers
09	TIN_OSCMP_VBG	TIN_OSCMP_VPTAT	Set the ZTC and PTAT signals used by the offset compensation circuit
0A	TIN_COMPREF	GND	Reference input to the comparator in the Capacitive AFE circuit
0B	TIN_CTOV_CLK	GND	Set the clock used by Capacitive AFE
0C	TIN_V1P65	GND	Set the internal 1.65V reference
0D	TIN_BG5	GND	Set the internal 5V bandgap reference signal
0E	TIN_TEMP_ADC	GND	Input to Temperature ADC
0F	TIN_SNSR_SUPPLY_REF	GND	Set the reference used by VBRG
10	TIN_IBIST_OTP	GND	Input current for OTP test
11	TOUT_IB10U_5V	TOUT_IB10U_3V	Bias current from 5V and 3V bandgaps

NOTE

The TEST MUX register is only meant to be used for debugging purposes. The performance of this test mux registers is not characterized.

7.10.4.7 Digital Test MUX In Register (DMUX_I)

Digital Test MUX In Register (DMUX_I)				Not Bit Addressable				
TEST:	0x09							
	BIT 7	BIT 6	BIT 5	BIT 4	BIT 3	BIT 2	BIT 1	BIT 0
	–	–	–	–	DMUX_I[3]	DMUX_I[2]	DMUX_I[1]	DMUX_I[0]
Access	r/w	r/w	r/w	r/w	r/w	r/w	r/w	r/w
At Reset	0	0	0	0	0	0	0	0

DMUX_I[3:0] (Hex)	TIP_D Connected to	Remark
00	GND	Reference
01	OTP_CLK	OTP Clock
02	SADC_PWM	Pressure ADC PWM Bit
03	TADC_PWM	Temperature ADC PWM Bit
04	CLK_ADC_1M	Pressure SDM Clock
05	CLK_TADC_128K	Temperature SDM Clock
06	CHOP_CLK_700K	Clock for first stage chopper amplifier
07	CLK_EE_CP	Clock for EEPROM charge pump
08	XINTR_ACK[5]	Interrupt Acknowledge
09	XINTR_ACK[7]	Interrupt Acknowledge
0A	XINTR_ACK[8]	Interrupt Acknowledge
0B	XINTR_ACK[9]	Interrupt Acknowledge
0C	XINTR_ACK[10]	Interrupt Acknowledge

NOTE

The TEST MUX register is only meant to be used for debugging purposes. The performance of this test mux registers is not characterized.

7.10.4.8 EEPROM Access Control Register (EEPROM_A)

EEPROM Access Control Register (EEPROM_A)				Not Bit Addressable				
TEST:	0x0D							
	BIT 7	BIT 6	BIT 5	BIT 4	BIT 3	BIT 2	BIT 1	BIT 0
	–	–	EE_BANK_RELOAD	IGN_PROG_TIMER	DI_EEPROG	EE_BANK_SEL[2]	EE_BANK_SEL[1]	EE_BANK_SEL[0]
Access	r/w	r/w	r/w	r/w	r/w	r/w	r/w	r/w
At Reset	0	0	0	0	0	0	0	0

Bit Definitions		
BIT 0: EE_BANK_SEL[0]	EE_BANK_SEL[0:2]	0b000: Bank 0
BIT 1: EE_BANK_SEL[1]	0b001: Bank 1 0b010: Bank 2	
BIT 2: EE_BANK_SEL[2]	0b011: Bank 3 0b100: Bank 4 0b101: Bank 5	
BIT 3: DI_EEPROG	0: No Action 1: Program EEPROM via Digital Interface (SPI, I2C, OWI)	
BIT 4: IGN_PROG_TIMER	0: DI_EEPROG is reset to 0 15ms after being set to 1 by Digital Interface 1: Program timer timeout is ignored	
BIT 5: EE_BANK_RELOAD	0: No Action 1: Force Reload current EEPROM bank contents into EEPROM cache	
BIT 6: –		
BIT 7: –		

7.10.4.9 Micro/Interface Control Register (MICRO_IF_SEL_T)

Micro/Interface Control Register (MICRO_IF_SEL_T)				Not Bit Addressable				
TEST:	0x0E							
	BIT 7	BIT 6	BIT 5	BIT 4	BIT 3	BIT 2	BIT 1	BIT 0
	–	–	–	–	–	–	MICRO_RESET	IF_SEL
Access	r/w	r/w	r/w	r/w	r/w	r/w	r/w	r/w
At Reset	0	0	0	0	0	0	0	0

Bit Definitions		
BIT 0: IF_SEL	0: 8051W microprocessor will access Memory (EEPROM, OTP, ESFR, RAM) 1: Digital Interface will access Memory	
BIT 1: MICRO_RESET	0: No Action 1: 8051W is in reset	
BIT 2: –		
BIT 3: –		
BIT 4: –		
BIT 5: –		
BIT 6: –		
BIT 7: –		

7.10.4.10 OWI Error Status 1 (OWI_ERR_1)

OWI Error Status 1 (OWI_ERR_1)				Not Bit Addressable				
TEST:	0x14							
	BIT 7	BIT 6	BIT 5	BIT 4	BIT 3	BIT 2	BIT 1	BIT 0
	OWI_ERR_1[7]	OWI_ERR_1[6]	OWI_ERR_1[5]	OWI_ERR_1[4]	OWI_ERR_1[3]	OWI_ERR_1[2]	OWI_ERR_1[1]	OWI_ERR_1[0]
Access	r/w	r/w	r/w	r/w	r/w	r/w	r/w	r/w
At Reset	0	0	0	0	0	0	0	0

Bit Definitions		
BIT 0: OWI_ERR_1[0]	0: No Error 1: SYNC Field bit rate is < 2000bps	
BIT 1: OWI_ERR_1[1]	0: No Error 1: SYNC Field bit rate is < `25Kbps	
BIT 2: OWI_ERR_1[2]	0: No Error 1: SYNC Field stop bit too short	
BIT 3: OWI_ERR_1[3]	0: No Error 1: CMD Field: incorrect stop bit value	
BIT 4: OWI_ERR_1[4]	0: No Error 1: CMD Field: stop bit too short	
BIT 5: OWI_ERR_1[5]	0: No Error 1: DATA Field: incorrect stop bit value	
BIT 6: OWI_ERR_1[6]	0: No Error 1: DATA Field; stop bit too short	
BIT 7: OWI_ERR_1[7]	0: No Error 1: DATA Field: slave transmit value overdriven to dominant value during stop bit transmit	

7.10.4.11 OWI Error Status 2 (OWI_ERR_2)

OWI Error Status 2 (OWI_ERR_2)				Not Bit Addressable				
TEST:	0x15							
	BIT 7	BIT 6	BIT 5	BIT 4	BIT 3	BIT 2	BIT 1	BIT 0
	-	-	-	-	-	-	OWI_ERR_2[1]	OWI_ERR_2[0]
Access	r/w	r/w	r/w	r/w	r/w	r/w	r/w	r/w
At Reset	0	0	0	0	0	0	0	0

Bit Definitions		
BIT 0: OWI_ERR_2[0]	0: No Error 1: Consecutive bits in the sync field are different by more than +/-25% tolerance	
BIT 1: OWI_ERR_2[1]	0: No Error 1: INVALID command sent through OWI protocol	
BIT 2: -	-	
BIT 3: -	-	
BIT 4: -	-	
BIT 5: -	-	
BIT 6: -	-	
BIT 7: -	-	

7.10.5 8051W Interrupts

MCU8051 provides the five standard 8051-compatible 'Legacy' interrupts, plus expansion capability for a further nine 'Extended' interrupts sourced from external user logic. The standard and extended interrupts each have separate enable register bits associated with them, allowing software control. They can also have two levels of priority assigned to them.

7.10.5.1 Standard Interrupts

The five standard interrupts comprise two timer overflow interrupts, an interrupt associated with the core's built-in serial interface, and two external interrupts (referred to as 'Legacy' external interrupts).

The two timer overflow interrupts, TF0 and TF1, are set whenever timer 0 or timer 1 respectively roll-over to zero. The states of these interrupts are also stored in the TCON register. TF0 and TF1 are automatically cleared by hardware on entry to the corresponding interrupt service routine.

The Serial interrupt source comprises the logical OR of the two serial interface status bits RI and TI in register SCON. These are set automatically upon receipt or transmission of a data frame. These two bits are not cleared by hardware.

The Legacy external interrupts, NINT0 and NINT1, are driven from inputs PORT3(2) and PORT3(3) respectively. These interrupts may be either edge- or level-sensitive, depending on settings within the TCON register. Two further TCON register bits, IE0 and IE1, act as interrupt flags. If the external interrupt is set to edge-triggered, the corresponding register bit IE0/1 is set by a falling edge on NINT0/1 and cleared by hardware on entry to the corresponding interrupt service routine. If the interrupt is set to be level-sensitive, IE0/1 reflects the logic level on NINT0/1. (The TCON register is described in Section 5.2.5.1).

NOTE

All events on NINT0 and NINT1, whether level-triggered or edge-triggered, are detected by sampling the relevant interrupt line on the rising edge of SCLK at the end of Phase 1 of every machine cycle. Where NINT0/NINT1 is level-triggered, a response is made to the signal being sampled low and, to ensure detection, the external source needs to hold the line low until the resulting interrupt is generated. (It also needs to ensure that the request is de-activated before the end of the associated service routine.) Where NINT0/NINT1 is edge-triggered, the response is made to a transition on the signal from high to low between successive samples. This means that, to ensure detection, NINT0/NINT1 needs to have been high for at least two clocks before it goes low and then needs to be held low for at least two clocks after this transition.

(Further information about these five standard interrupts can be found, for example, in the Intel 8-Bit Embedded Controller Handbook in the 'Hardware Description of the 8051, 8052 & 80C51'.)

7.10.5.2 Extended Interrupts

Source and acknowledge signals are provided for a further nine interrupts. These interrupts are driven from external user logic, typically a user ESFR. The extended interrupts are input to the core on bits 5 to 13 of input bus XINTR_SRC, while acknowledge signals are output from the core on bits 5 to 13 of bus XINTR_ACK. Note: If the timers or the UART are omitted from the design, their corresponding interrupt inputs (plus those of the Legacy external interrupts where the timers are omitted) are made available at the core periphery as XINTR_SRC[4:0], along with corresponding XINTR_ACK acknowledge signals, for use as additional Extended interrupts.)

The extended interrupt lines are sampled on the rising edge of PCLK at the beginning of Phase 2 of the last cycle of the current instruction. To ensure detection, the external source needs to hold the XINTR_SRC line high until the resulting interrupt is generated. (It also needs to ensure that the request is deactivated before the end of the associated service routine.). Note: Any edge-triggering that is required will need to be taken care of by individual peripherals.

7.10.5.2.1 Interrupt Flag Clear

If the Legacy external interrupts NINT0 and NINT1 are edge triggered, the interrupt flag is cleared on vectoring to the service routine. If they are level triggered, the flag is controlled by the external signal. Timer/counter flags are cleared on vectoring to the interrupt service routine but the serial interrupt flag is not affected by hardware. The serial interrupt flag should be cleared by software. Acknowledge signals are provided for clearing any registers used to source the nine additional interrupts.

7.10.5.2.2 Priority Levels / Interrupt Vectors

One of two priority levels may be selected for each interrupt. An interrupt of a high priority may interrupt the service routine of a low priority interrupt and, if two interrupts of different priority occur at the same time, the higher level interrupt will be serviced first. An interrupt cannot be interrupted by another interrupt of the same priority level. If two interrupts of the same priority level occur simultaneously, a polling sequence is observed. The polling sequence is described in Table 21.

When an interrupt is serviced, a long call instruction is executed to an address location, according to the interrupt's source: The interrupt vector addresses for each interrupt is listed in Table 21.

Table 21. Interrupt Summary.
The entries that are greyed out in the above table are not available for use in the PGA400-Q1.

8051W Source	PGA400	Vector Address	Polling Sequence	Flag	Enable	Priority Control
External Interrupt 0 (GPIO_5)	GPIO_5	0x0003	1 (Highest)	IE0 (TCON.1)	EX0 (IE.0)	PX0 (IP.0)
Timer/Counter Interrupt 0	←	0x000B	2	TF0 (TCON.5)	ET0 (IE.1)	PT0 (IP.1)
External Interrupt 1		0x0013	3	IE1 (TCON.3)	EX1 (IE.2)	PX1 (IP.2)
Timer/Counter Interrupt 1	←	0x001B	4	TF1 (TCON.7)	ET1 (IE.3)	PT1 (IP.3)
Serial Port 0	←	0x0023	5	RI_0 (SCON0.0) TI_0 (SCON0.1)	ES0 (IE.4)	PS0 (IP.4)
External Interrupt 5	OWI ACTIVATION	0x002B	6	-	EI5 (IE.5)	PI5 (IP.5)
External Interrupt 6	COMM DATA BUFFER	0x0033	7	-	EI6 (IE1.0)	PI6 (IP1.0)
External Interrupt 7	IC_1	0x003B	8	-	EI7 (IE1.1)	PI7 (IP1.1)
External Interrupt 8	IC_2	0x0043	9	-	EI8 (IE1.2)	PI8 (IP1.2)
External Interrupt 9	OC_1	0x004B	10	-	EI9 (IE1.3)	PI9 (IP1.3)
External Interrupt 10	OC_2	0x0053	11	-	EI10 (IE1.4)	P10 (IP1.4)
External Interrupt 11	Signal Channel 1st Stage Decimator	0x005B	12	-	EI11 (IE1.5)	P11 (IP1.5)
External Interrupt 12	Signal Channel 2nd Stage Decimator	0x0063	13	-	EI12 (IE1.6)	P12 (IP1.6)
External Interrupt 13		0x006B	14 (Lowest)	-	EI13 (IE1.7)	P13 (IP.7)

7.10.5.2.3 Interrupt Latency

The response time in a single interrupt system is between 3 and 9 machine cycles.

7.10.6 8051 Instructions

The M8051 Warp instruction set is shown as a table in a following section. Some of the features supported are outlined below.

7.10.6.1 Addressing Modes

The M8051 Warp provides a variety of addressing modes, which are outlined below.

7.10.6.1.1 Direct Addressing

In Direct Addressing, the operand is specified by an 8-bit address field. Only internal data and SFRs may be accessed using this mode.

7.10.6.1.2 Indirect Addressing

In Indirect Addressing, the operand is specified by an address contained in a register. Two registers (R0 and R1) from the current bank or the Data Pointer may be used for addressing in this mode. Both internal and external Data Memory may be indirectly addressed.

7.10.6.1.3 Register Addressing

In Register Addressing, the operand is specified by the top 3 bits of the opcode, which selects one of the current bank of registers. Four banks of registers are available. The current bank is selected by bits 3 and 4 of the PSW.

7.10.6.1.4 Register Specific Addressing

Some instructions only operate on specific registers. This is defined by the opcode. In particular many accumulator operations and some stack pointer operations are defined in this manner.

7.10.6.1.5 Immediate Data

Instructions which use Immediate Data are 2 or 3 bytes long and the Immediate operand is stored in Program Memory as part of the instruction.

7.10.6.1.6 Indexed Addressing

Only Program Memory may be addressed using Indexed Addressing. It is intended for simple implementation of look-up tables. A 16-bit base register (either the PC or the DPTR) is combined with an offset stored in the accumulator to access data in Program Memory.

7.10.6.2 Arithmetic Instructions

The M8051 Warp implements ADD, ADDC (Add with Carry), SUBB (Subtract with Borrow), INC (Increment) and DEC (Decrement) functions, which may be used in most addressing modes. There are three accumulator-specific instructions, DA A (Decimal Adjust A), MUL AB (Multiply A by B) and DIV AB (Divide A by B).

7.10.6.3 Logical Instructions

The M8051 Warp implements ANL (AND Logical), ORL (OR Logical), and XRL (Exclusive-OR Logical) functions, which again may be used in most addressing modes. There are seven accumulator-specific instructions, CLR A (Clear A), CPL A (Complement A), RL A (Rotate Left A), RLC A (Rotate Left through Carry A), RR A (Rotate Right A), RRC A (Rotate Right through Carry A), and SWAP A (Swap Nibbles of A).

7.10.6.4 Data Transfers

7.10.6.4.1 Internal Data Memory

Data may be moved from the accumulator to any Internal Data Memory location, from any Internal Data Memory location to the accumulator, and from any Internal Data Memory location to any SFR or other Internal Data Memory location.

7.10.6.4.2 External Data Memory

Data may be moved from the accumulator to or from an external memory location in one of two addressing modes. In 8-bit addressing mode, the external location is addressed by either R0 or R1; in 16-bit addressing mode, the location is addressed by the DPTR.

7.10.6.5 Jump Instructions

7.10.6.5.1 Unconditional Jumps

Four sorts of unconditional jump instructions are available. Short jumps (SJMP) are relative jumps (limited to -128 to +127 bytes), Long jumps (LJMP) are absolute 16-bit jumps and Absolute jumps (AJMP) are absolute 11-bit jumps (ie. within a 2K byte memory page). The last type is an Indexed jump, JMP @A+DPTR, which jumps to a location contained in the DPTR register, offset by a value stored in the accumulator.

7.10.6.5.2 Subroutine Calls and Returns

There are only two sorts of subroutine call, ACALL and LCALL, which are Absolute and Long as above. Two return instructions are provided, RET and RETI. The latter is for interrupt service routines.

7.10.6.5.3 Conditional Jumps

Conditional jump instructions all use relative addressing, so are limited to the same -128 to +127 byte range as above.

7.10.6.5.4 Boolean Instructions

The bit-addressable registers in both direct and SFR space may be manipulated using Boolean instructions. Logical functions are available which use the carry flag and an addressable bit as the operands and each addressable bit may be set, cleared or tested in a jump instruction.

7.10.6.6 Flags

The following instructions affect flags generated by the ALU:

Instruction	Flag			Instruction	Flag		
	C	OV	AC		C	OV	AC
ADD	?	?	?	CLRC	0		
ADDC	?	?	?	CPLC	?		
SUBB	?	?	?	ANL C, bit	?		
MUL	0	?		ANL C, /bit	?		
DIV	0	?		ORL C, bit	?		
DA	?			ORL C, /bit	?		
RRC	?			MOV C, bit	?		
RLC	?			CJNE	?		
SETB C	1						

In the above table, a 0 means the flag is always cleared, a 1 means the flag is always set and an “?” means that the state of the flag depends on the result of the operation. The Flag specified as Blank means that the state is unknown.

7.10.6.7 Instruction Table

Instructions are either 1, 2 or 3 bytes long as listed in the 'Bytes' column below. Each instruction takes either 1, 2 or 4 machine cycles to execute as listed in the following table. 1 machine cycle comprises 2 CCLK clock cycles.

ARITHMETIC				
Mnemonic	Description	Bytes	Cycles	Hex code
ADD A,Rn	Add register to A	1	1	28–2F
ADD A,dir	Add direct byte to A	2	1	25
ADD A,@Ri	Add indirect memory to A	1	1	26–27
ADD A,#data	Add immediate to A	2	1	24
ADDC A,Rn	Add register to A with carry	1	1	38–3F
ADDC A,dir	Add direct byte to A with carry	2	1	35
ADDC A,@Ri	Add indirect memory to A with carry	1	1	36–37
ADDC A,#data	Add immediate to A with carry	2	1	34
SUBB A,Rn	Subtract register from A with borrow	1	1	98–9F
SUBB A,dir	Subtract direct byte from A with borrow	2	1	95
SUBB A,@Ri	Subtract indirect memory from A with borrow	1	1	96–97
SUBB A,#data	Subtract immediate from A with borrow	2	1	94
INC A	Increment A	1	1	04
INC Rn	Increment register	1	1	08–0F
INC dir	Increment direct byte	2	1	05
INC @Ri	Increment indirect memory	1	1	06–07
DEC A	Decrement A	1	1	14
DEC Rn	Decrement register	1	1	18–1F
DEC dir	Decrement direct byte	2	1	15
DEC @Ri	Decrement indirect memory	1	1	16–17
INC DPTR	Increment data pointer	1	2	A3
MUL AB	Multiply A by B	1	4	A4
DIV AB	Divide A by B	1	4	84
DA A	Decimal Adjust A	1	1	D4
LOGICAL				
ANL A,Rn	AND register to A	1	1	58–5F
ANL A,dir	AND direct byte to A	2	1	55
ANL A,@Ri	AND indirect memory to A	1	1	56–57
ANL A,#data	AND immediate to A	2	1	54
ANL dir,A	AND A to direct byte	2	1	52
ANL dir,#data	AND immediate to direct byte	3	2	53
ORL A,Rn	OR register to A	1	1	48–4F
ORL A,dir	OR direct byte to A	2	1	45
ORL A,@Ri	OR indirect memory to A	1	1	46–47
ORL A,#data	OR immediate to A	2	1	44
ORL dir,A	OR A to direct byte	2	1	42
ORL dir,#data	OR immediate to direct byte	3	2	43
XRL A,Rn	Exclusive-OR register to A	1	1	68–6F
XRL A,dir	Exclusive-OR direct byte to A	2	1	65
XRL A,@Ri	Exclusive-OR indirect memory to A	1	1	66–67
XRL A,#data	Exclusive-OR immediate to A	2	1	64
XRL dir,A	Exclusive-OR A to direct byte	2	1	62
XRL dir,#data	Exclusive-OR immediate to direct byte	3	2	63
CLR A	Clear A	1	1	E4

ARITHMETIC				
Mnemonic	Description	Bytes	Cycles	Hex code
CPL A	Complement A	1	1	F4
SWAP A	Swap Nibbles of A	1	1	C4
RL A	Rotate A left	1	1	23
RLC A	Rotate A left through carry	1	1	33
RR A	Rotate A right	1	1	03
RRC A	Rotate A right through carry	1	1	13
DATA TRANSFER				
MOV A,Rn	Move register to A	1	1	E8–EF
MOV A,dir	Move direct byte to A	2	1	E5
MOV A,@Ri	Move indirect memory to A	1	1	E6–E7
MOV A,#data	Move immediate to A	2	1	74
MOV Rn,A	Move A to register	1	1	F8–FF
MOV Rn,dir	Move direct byte to register	2	2	A8–AF
MOV Rn,#data	Move immediate to register	2	1	78–7F
MOV dir,A	Move A to direct byte	2	1	F5
MOV dir,Rn	Move register to direct byte	2	2	88–8F
MOV dir,dir	Move direct byte to direct byte	3	2	85
MOV dir,@Ri	Move indirect memory to direct byte	2	2	86–87
MOV dir,#data	Move immediate to direct byte	3	2	75
MOV @Ri,A	Move A to indirect memory	1	1	F6–F7
MOV @Ri,dir	Move direct byte to indirect memory	2	2	A6–A7
MOV @Ri,#data	Move immediate to indirect memory	2	1	76–77
MOV DPTR,#data	Move immediate to data pointer	3	2	90
MOVC A,@A+DPTR	Move code byte relative DPTR to A	1	2	93
MOVC A,@A+PC	Move code byte relative PC to A	1	2	83
MOVX A,@Ri	Move external data(A8) to A	1	2	E2–E3
MOVX A,@DPTR	Move external data(A16) to A	1	2	E0
MOVX @Ri,A	Move A to external data(A8)	1	2	F2–F3
MOVX @DPTR,A	Move A to external data(A16)	1	2	F0
PUSH dir	Push direct byte onto stack			C0
POP dir	Pop direct byte from stack			D0
XCH A,Rn	Exchange A and register			C8–CF
XCH A,dir	Exchange A and direct byte			C5
XCH A,@Ri	Exchange A and indirect memory			C6–C7
XCHD A,@Ri	Exchange A and indirect memory nibble			D6–D7
BOOLEAN				
CLR C	Clear carry	1	1	C3
CLR bit	Clear direct bit	2	1	C2
SETB C	Set carry	1	1	D3
SETB bit	Set direct bit	2	1	D2
CPL C	Complement carry	1	1	B3
CPL bit	Complement direct bit	2	1	B2
ANL C,bit	AND direct bit to carry	2	2	82
ANL C,/bit	AND direct bit inverse to carry	2	2	B0
ORL C,bit	OR direct bit to carry	2	2	72
ORL C,/bit	OR direct bit inverse to carry	2	2	A0
MOV C,bit	Move direct bit to carry	2	1	A2
MOV bit,C	Move carry to direct bit	2	2	92

PGA400-Q1

SLDS186A – MARCH 2012 – REVISED JULY 2016

www.ti.com

ARITHMETIC				
Mnemonic	Description	Bytes	Cycles	Hex code
BRANCHING				
ACALL addr 11	Absolute jump to subroutine	2	2	11→F1
LCALL addr 16	Long jump to subroutine	3	2	12
RET	Return from subroutine	1	2	22
RETI	Return from interrupt	1	2	32
AJMP addr 11	Absolute jump unconditional	2	2	01→E1
LJMP addr 16	Long jump unconditional	3	2	02
SJMP rel	Short jump (relative address)	2	2	80
JC rel	Jump on carry = 1	2	2	40
JNC rel	Jump on carry = 0	2	2	50
JB bit,rel	Jump on direct bit = 1	3	2	20
JNB bit,rel	Jump on direct bit = 0	3	2	30
JBC bit,rel	Jump on direct bit = 1 and clear	3	2	10
JMP @A+DPTR	Jump indirect relative DPTR	1	2	73
JZ rel	Jump on accumulator = 0	2	2	60
JNZ rel	Jump on accumulator ≠ 0	2	2	70
CJNE A,dir,rel	Compare A,direct jne relative	3	2	B5
CJNE A,#d,rel	Compare A,immediate jne relative	3	2	B4
CJNE Rn,#d,rel	Compare register, immediate jne relative	3	2	B8–BF
CJNE @Ri,#d,rel	Compare indirect, immediate jne relative	3	2	B6–B7
DJNZ Rn,rel	Decrement register, jnz relative	2	2	D8–DF
DJNZ dir,rel	Decrement direct byte, jnz relative	3	2	D5
MISCELLANEOUS				
NOP	No operation	1	1	00

In the above table, an entry such as E8-EF indicates a continuous block of hex opcodes used for 8 different registers, the register numbers of which are defined by the lowest three bits of the corresponding code. Non-continuous blocks of codes, shown as 11→F1 (for example), are used for absolute jumps and calls, with the top 3 bits of the code being used to store the top three bits of the destination address. The CJNE instructions use the abbreviation #d for immediate data; other instructions use #data.

8 Application and Implementation

NOTE

Information in the following applications sections is not part of the TI component specification, and TI does not warrant its accuracy or completeness. TI's customers are responsible for determining suitability of components for their purposes. Customers should validate and test their design implementation to confirm system functionality.

8.1 Typical Application

8.1.1 Resistive Bridge Interface

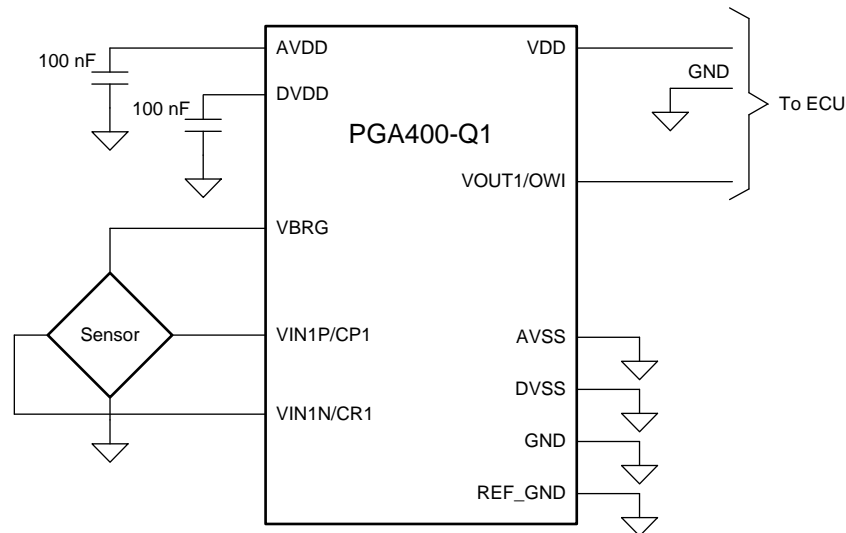

Figure 60. Resistive Bridge Interface

8.1.1.1 Capacitive Sensor Interface

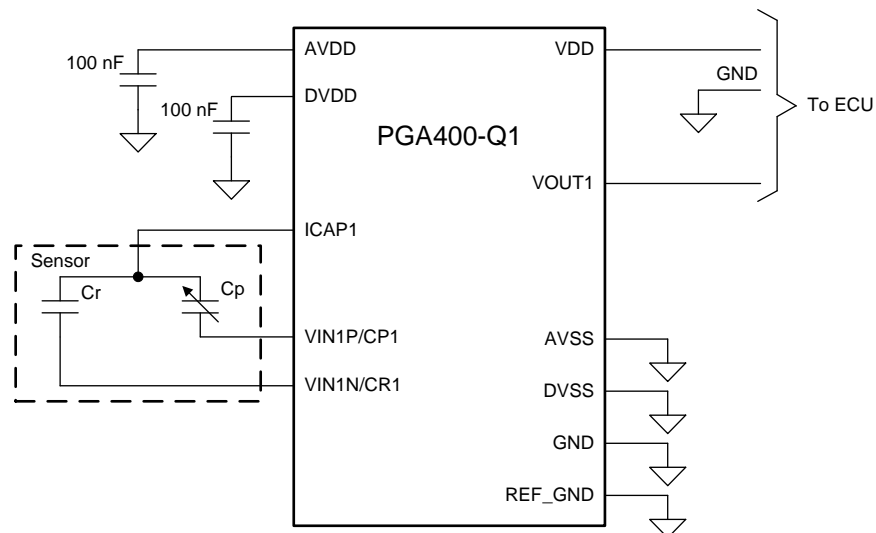

Figure 61. Capacitive Sensor Interface

9 Device and Documentation Support

9.1 Documentation Support

9.1.1 Related Documentation

For related documentation see the following:

- *PGA400-Q1 EVM User Guide*, [SLDU010](#)
- *PGA400-Q1 Errata*, [SLDZ002](#)
- *Shelf-Life Evaluation of Lead-Free Component Finishes*, [SZZA046](#)

9.2 Receiving Notification of Documentation Updates

To receive notification of documentation updates, navigate to the device product folder on ti.com. In the upper right corner, click on *Alert me* to register and receive a weekly digest of any product information that has changed. For change details, review the revision history included in any revised document.

9.3 Community Resources

The following links connect to TI community resources. Linked contents are provided "AS IS" by the respective contributors. They do not constitute TI specifications and do not necessarily reflect TI's views; see TI's [Terms of Use](#).

TI E2E™ Online Community *TI's Engineer-to-Engineer (E2E) Community*. Created to foster collaboration among engineers. At e2e.ti.com, you can ask questions, share knowledge, explore ideas and help solve problems with fellow engineers.

Design Support *TI's Design Support* Quickly find helpful E2E forums along with design support tools and contact information for technical support.

9.4 Trademarks

E2E is a trademark of Texas Instruments.
All other trademarks are the property of their respective owners.

9.5 Electrostatic Discharge Caution



These devices have limited built-in ESD protection. The leads should be shorted together or the device placed in conductive foam during storage or handling to prevent electrostatic damage to the MOS gates.

9.6 Glossary

[SLYZ022](#) — *TI Glossary*.

This glossary lists and explains terms, acronyms, and definitions.

10 Mechanical, Packaging, and Orderable Information

The following pages include mechanical, packaging, and orderable information. This information is the most current data available for the designated devices. This data is subject to change without notice and revision of this document. For browser-based versions of this data sheet, refer to the left-hand navigation.

PACKAGING INFORMATION

Orderable Device	Status (1)	Package Type	Package Drawing	Pins	Package Qty	Eco Plan (2)	Lead/Ball Finish (6)	MSL Peak Temp (3)	Op Temp (°C)	Device Marking (4/5)	Samples
PGA400QRHHRQ1	ACTIVE	VQFN	RHH	36	2500	Green (RoHS & no Sb/Br)	CU NIPDAU	Level-3-260C-168 HR	-40 to 125	PGA400Q RHH-Q100	Samples
PGA400QYZSRQ1	ACTIVE	DSBGA	YZS	36	1500	Green (RoHS & no Sb/Br)	SNAGCU	Level-1-260C-UNLIM	-40 to 125	PGA400	Samples

(1) The marketing status values are defined as follows:

ACTIVE: Product device recommended for new designs.

LIFEBUY: TI has announced that the device will be discontinued, and a lifetime-buy period is in effect.

NRND: Not recommended for new designs. Device is in production to support existing customers, but TI does not recommend using this part in a new design.

PREVIEW: Device has been announced but is not in production. Samples may or may not be available.

OBSELETE: TI has discontinued the production of the device.

(2) Eco Plan - The planned eco-friendly classification: Pb-Free (RoHS), Pb-Free (RoHS Exempt), or Green (RoHS & no Sb/Br) - please check <http://www.ti.com/productcontent> for the latest availability information and additional product content details.

TBD: The Pb-Free/Green conversion plan has not been defined.

Pb-Free (RoHS): TI's terms "Lead-Free" or "Pb-Free" mean semiconductor products that are compatible with the current RoHS requirements for all 6 substances, including the requirement that lead not exceed 0.1% by weight in homogeneous materials. Where designed to be soldered at high temperatures, TI Pb-Free products are suitable for use in specified lead-free processes.

Pb-Free (RoHS Exempt): This component has a RoHS exemption for either 1) lead-based flip-chip solder bumps used between the die and package, or 2) lead-based die adhesive used between the die and leadframe. The component is otherwise considered Pb-Free (RoHS compatible) as defined above.

Green (RoHS & no Sb/Br): TI defines "Green" to mean Pb-Free (RoHS compatible), and free of Bromine (Br) and Antimony (Sb) based flame retardants (Br or Sb do not exceed 0.1% by weight in homogeneous material)

(3) MSL, Peak Temp. - The Moisture Sensitivity Level rating according to the JEDEC industry standard classifications, and peak solder temperature.

(4) There may be additional marking, which relates to the logo, the lot trace code information, or the environmental category on the device.

(5) Multiple Device Markings will be inside parentheses. Only one Device Marking contained in parentheses and separated by a "~" will appear on a device. If a line is indented then it is a continuation of the previous line and the two combined represent the entire Device Marking for that device.

(6) Lead/Ball Finish - Orderable Devices may have multiple material finish options. Finish options are separated by a vertical ruled line. Lead/Ball Finish values may wrap to two lines if the finish value exceeds the maximum column width.

Important Information and Disclaimer: The information provided on this page represents TI's knowledge and belief as of the date that it is provided. TI bases its knowledge and belief on information provided by third parties, and makes no representation or warranty as to the accuracy of such information. Efforts are underway to better integrate information from third parties. TI has taken and continues to take reasonable steps to provide representative and accurate information but may not have conducted destructive testing or chemical analysis on incoming materials and chemicals. TI and TI suppliers consider certain information to be proprietary, and thus CAS numbers and other limited information may not be available for release.

In no event shall TI's liability arising out of such information exceed the total purchase price of the TI part(s) at issue in this document sold by TI to Customer on an annual basis.

TAPE AND REEL INFORMATION



QUADRANT ASSIGNMENTS FOR PIN 1 ORIENTATION IN TAPE



*All dimensions are nominal

Device	Package Type	Package Drawing	Pins	SPQ	Reel Diameter (mm)	Reel Width W1 (mm)	A0 (mm)	B0 (mm)	K0 (mm)	P1 (mm)	W (mm)	Pin1 Quadrant
PGA400QRHHRQ1	VQFN	RHH	36	2500	330.0	16.4	6.3	6.3	1.1	12.0	16.0	Q2
PGA400QYZSRQ1	DSBGA	YZS	36	1500	180.0	12.4	3.79	3.79	0.71	8.0	12.0	Q1

TAPE AND REEL BOX DIMENSIONS



*All dimensions are nominal

Device	Package Type	Package Drawing	Pins	SPQ	Length (mm)	Width (mm)	Height (mm)
PGA400QRHHRQ1	VQFN	RHH	36	2500	367.0	367.0	38.0
PGA400QYZSRQ1	DSBGA	YZS	36	1500	210.0	185.0	35.0

MECHANICAL DATA

RHH (S-PVQFN-N36)

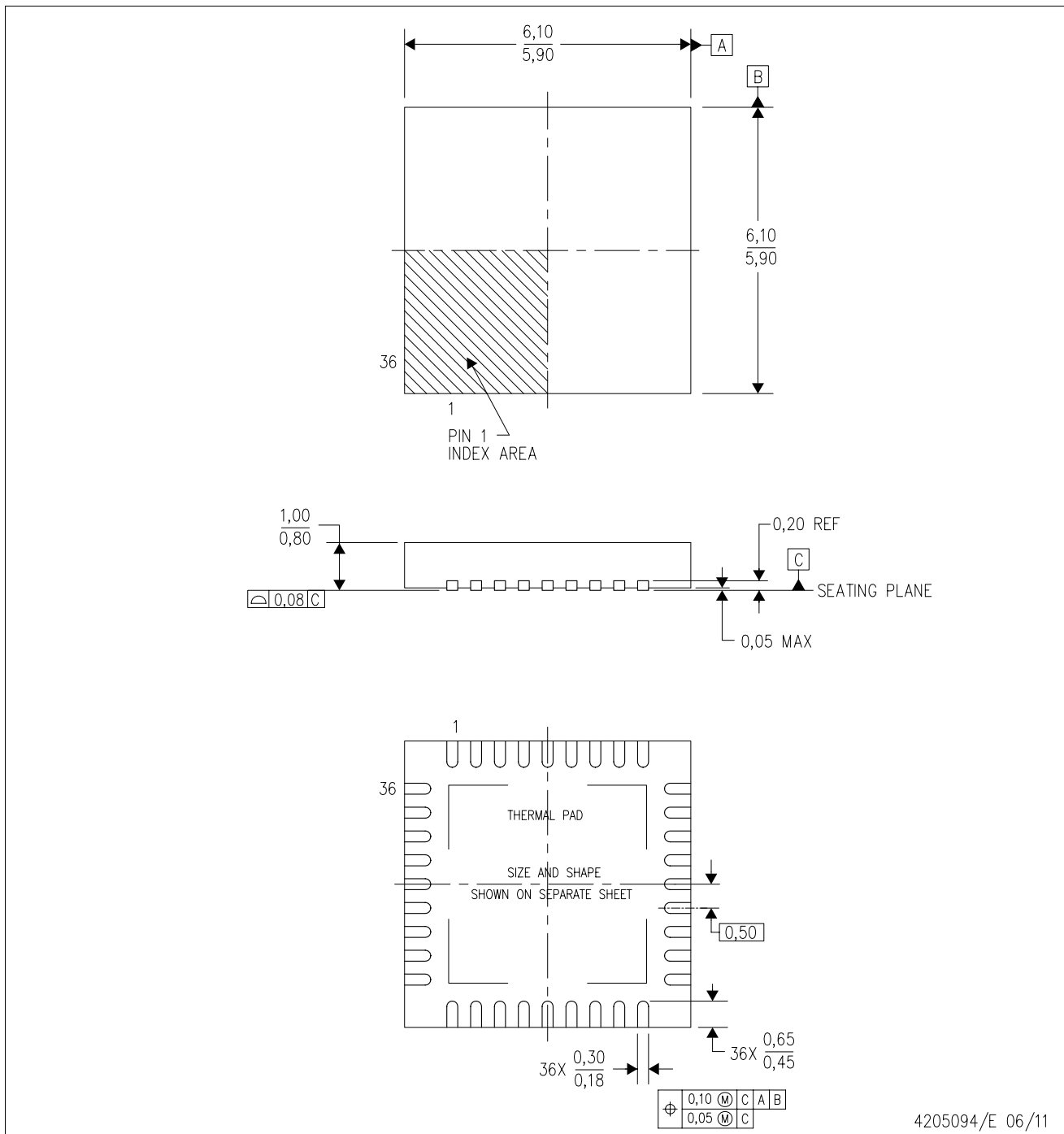
PLASTIC QUAD FLATPACK NO-LEAD



4205094/E 06/11

- NOTES:
- A. All linear dimensions are in millimeters. Dimensioning and tolerancing per ASME Y14.5M-1994.
 - B. This drawing is subject to change without notice.
 - C. QFN (Quad Flatpack No-Lead) Package configuration.
 - D. The package thermal pad must be soldered to the board for thermal and mechanical performance.
 - E. See the additional figure in the Product Data Sheet for details regarding the exposed thermal pad features and dimensions.
 - F. Falls within JEDEC MO-220.

THERMAL PAD MECHANICAL DATA

RHH (S-PVQFN-N36)

PLASTIC QUAD FLATPACK NO-LEAD

THERMAL INFORMATION

This package incorporates an exposed thermal pad that is designed to be attached directly to an external heatsink. The thermal pad must be soldered directly to the printed circuit board (PCB). After soldering, the PCB can be used as a heatsink. In addition, through the use of thermal vias, the thermal pad can be attached directly to the appropriate copper plane shown in the electrical schematic for the device, or alternatively, can be attached to a special heatsink structure designed into the PCB. This design optimizes the heat transfer from the integrated circuit (IC).

For information on the Quad Flatpack No-Lead (QFN) package and its advantages, refer to Application Report, QFN/SON PCB Attachment, Texas Instruments Literature No. SLUA271. This document is available at www.ti.com.

The exposed thermal pad dimensions for this package are shown in the following illustration.

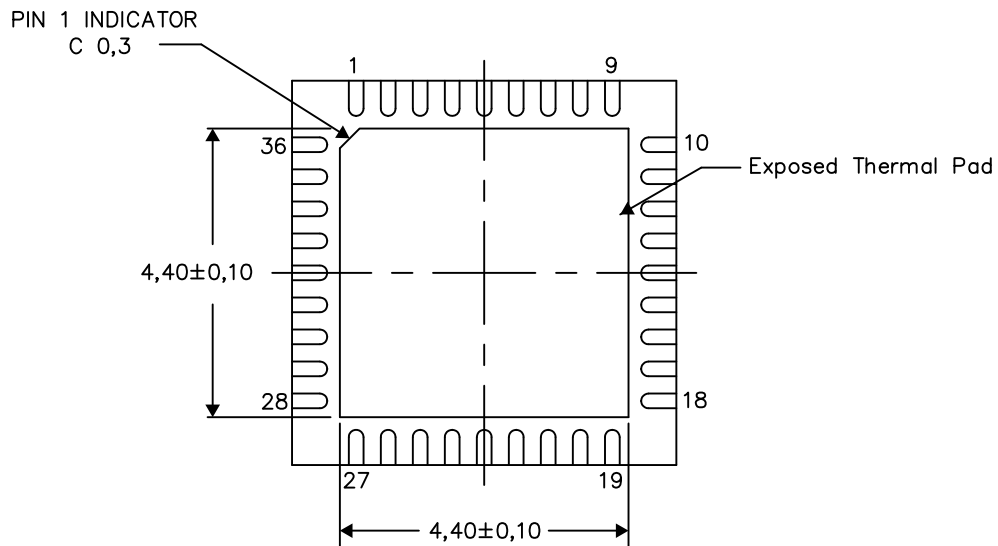

Bottom View

Exposed Thermal Pad Dimensions

4206362-5/M 11/13

NOTE: All linear dimensions are in millimeters

RHH (S-PVQFN-N36)

PLASTIC QUAD FLATPACK NO-LEAD

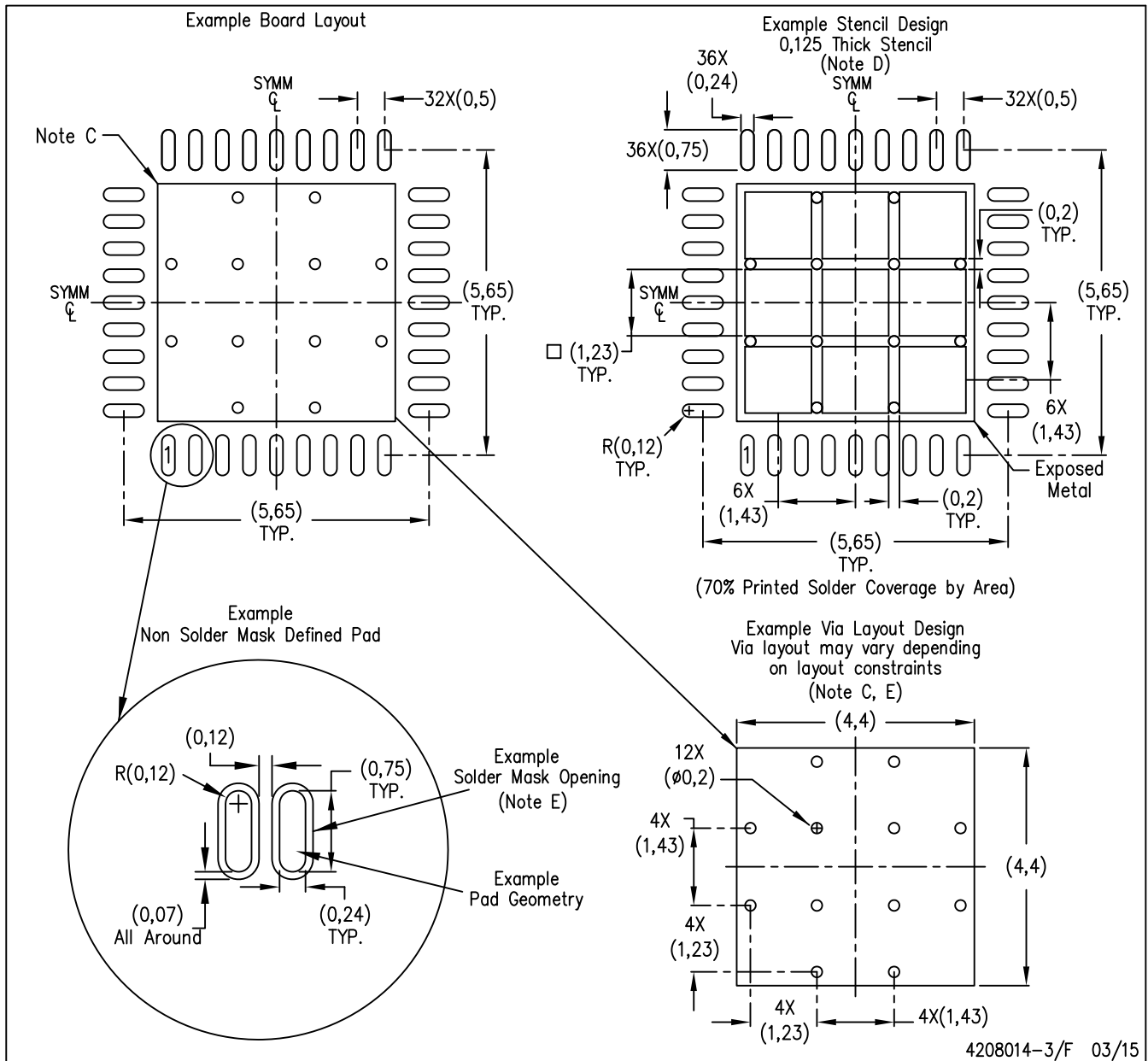

- NOTES:
- A. All linear dimensions are in millimeters.
 - B. This drawing is subject to change without notice.
 - C. This package is designed to be soldered to a thermal pad on the board. Refer to Application Note, Quad Flat-Pack Packages, Texas Instruments Literature No. SLUA271, and also the Product Data Sheets for specific thermal information, via requirements, and recommended board layout. These documents are available at www.ti.com <<http://www.ti.com>>.
 - D. Laser cutting apertures with trapezoidal walls and also rounding corners will offer better paste release. Customers should contact their board assembly site for stencil design recommendations. Refer to IPC 7525 for stencil design considerations.
 - E. Customers should contact their board fabrication site for recommended solder mask tolerances and via tenting recommendations for any larger diameter vias placed in the thermal pad.

YZS (S-XBGA-N36)

DIE-SIZE BALL GRID ARRAY

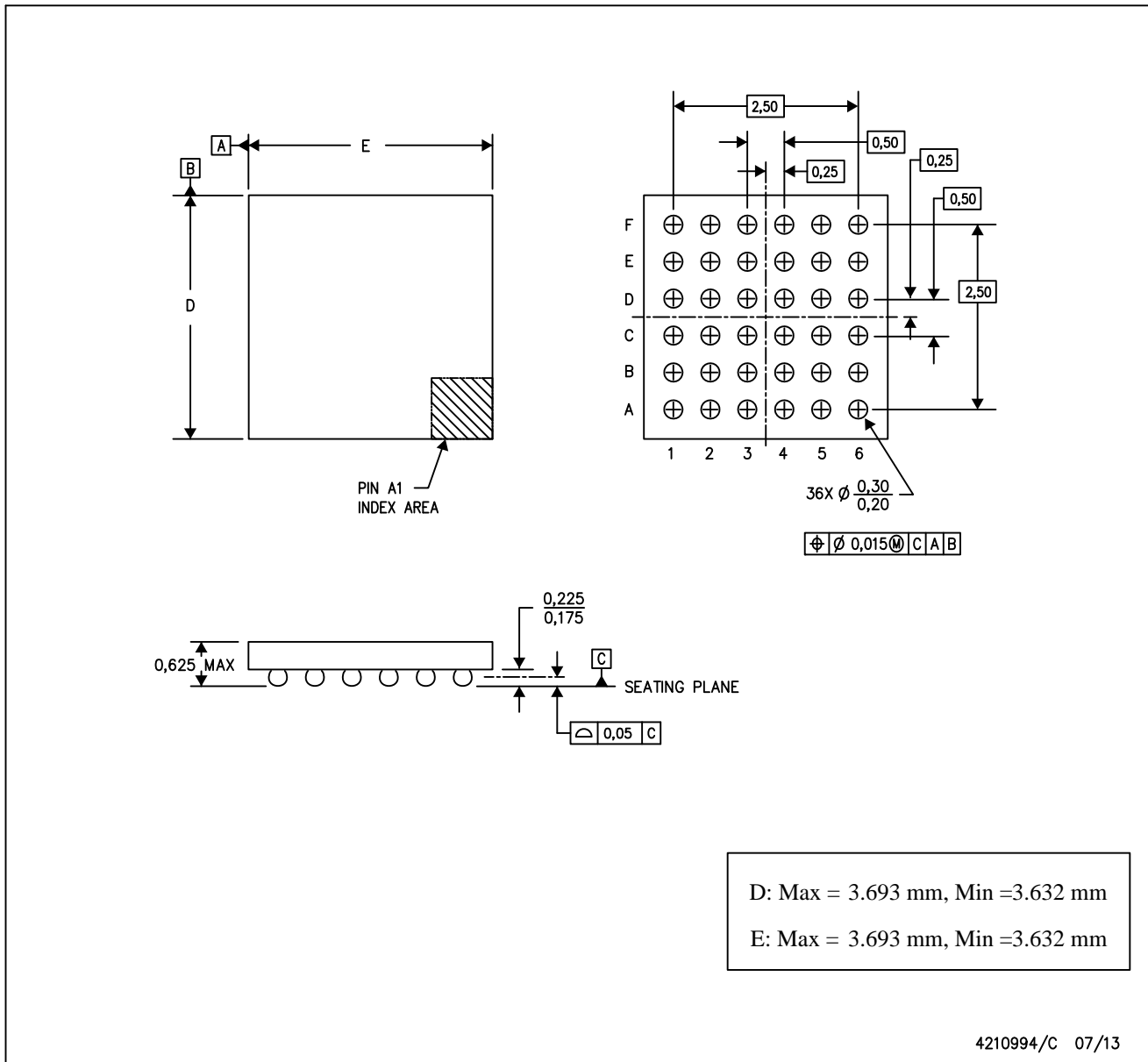

- NOTES: A. All linear dimensions are in millimeters. Dimensioning and tolerancing per ASME Y14.5-1994.
 B. This drawing is subject to change without notice.
 C. NanoFree™ package configuration.

IMPORTANT NOTICE

Texas Instruments Incorporated and its subsidiaries (TI) reserve the right to make corrections, enhancements, improvements and other changes to its semiconductor products and services per JESD46, latest issue, and to discontinue any product or service per JESD48, latest issue. Buyers should obtain the latest relevant information before placing orders and should verify that such information is current and complete. All semiconductor products (also referred to herein as "components") are sold subject to TI's terms and conditions of sale supplied at the time of order acknowledgment.

TI warrants performance of its components to the specifications applicable at the time of sale, in accordance with the warranty in TI's terms and conditions of sale of semiconductor products. Testing and other quality control techniques are used to the extent TI deems necessary to support this warranty. Except where mandated by applicable law, testing of all parameters of each component is not necessarily performed.

TI assumes no liability for applications assistance or the design of Buyers' products. Buyers are responsible for their products and applications using TI components. To minimize the risks associated with Buyers' products and applications, Buyers should provide adequate design and operating safeguards.

TI does not warrant or represent that any license, either express or implied, is granted under any patent right, copyright, mask work right, or other intellectual property right relating to any combination, machine, or process in which TI components or services are used. Information published by TI regarding third-party products or services does not constitute a license to use such products or services or a warranty or endorsement thereof. Use of such information may require a license from a third party under the patents or other intellectual property of the third party, or a license from TI under the patents or other intellectual property of TI.

Reproduction of significant portions of TI information in TI data books or data sheets is permissible only if reproduction is without alteration and is accompanied by all associated warranties, conditions, limitations, and notices. TI is not responsible or liable for such altered documentation. Information of third parties may be subject to additional restrictions.

Resale of TI components or services with statements different from or beyond the parameters stated by TI for that component or service voids all express and any implied warranties for the associated TI component or service and is an unfair and deceptive business practice. TI is not responsible or liable for any such statements.

Buyer acknowledges and agrees that it is solely responsible for compliance with all legal, regulatory and safety-related requirements concerning its products, and any use of TI components in its applications, notwithstanding any applications-related information or support that may be provided by TI. Buyer represents and agrees that it has all the necessary expertise to create and implement safeguards which anticipate dangerous consequences of failures, monitor failures and their consequences, lessen the likelihood of failures that might cause harm and take appropriate remedial actions. Buyer will fully indemnify TI and its representatives against any damages arising out of the use of any TI components in safety-critical applications.

In some cases, TI components may be promoted specifically to facilitate safety-related applications. With such components, TI's goal is to help enable customers to design and create their own end-product solutions that meet applicable functional safety standards and requirements. Nonetheless, such components are subject to these terms.

No TI components are authorized for use in FDA Class III (or similar life-critical medical equipment) unless authorized officers of the parties have executed a special agreement specifically governing such use.

Only those TI components which TI has specifically designated as military grade or "enhanced plastic" are designed and intended for use in military/aerospace applications or environments. Buyer acknowledges and agrees that any military or aerospace use of TI components which have **not** been so designated is solely at the Buyer's risk, and that Buyer is solely responsible for compliance with all legal and regulatory requirements in connection with such use.

TI has specifically designated certain components as meeting ISO/TS16949 requirements, mainly for automotive use. In any case of use of non-designated products, TI will not be responsible for any failure to meet ISO/TS16949.

Products

Audio	www.ti.com/audio
Amplifiers	amplifier.ti.com
Data Converters	dataconverter.ti.com
DLP® Products	www.dlp.com
DSP	dsp.ti.com
Clocks and Timers	www.ti.com/clocks
Interface	interface.ti.com
Logic	logic.ti.com
Power Mgmt	power.ti.com
Microcontrollers	microcontroller.ti.com
RFID	www.ti-rfid.com
OMAP Applications Processors	www.ti.com/omap
Wireless Connectivity	www.ti.com/wirelessconnectivity

Applications

Automotive and Transportation	www.ti.com/automotive
Communications and Telecom	www.ti.com/communications
Computers and Peripherals	www.ti.com/computers
Consumer Electronics	www.ti.com/consumer-apps
Energy and Lighting	www.ti.com/energy
Industrial	www.ti.com/industrial
Medical	www.ti.com/medical
Security	www.ti.com/security
Space, Avionics and Defense	www.ti.com/space-avionics-defense
Video and Imaging	www.ti.com/video

TI E2E Community

e2e.ti.com