

Clock Generator for ATI[®] RS480 Chipset

Features

- Supports AMD[®] CPU
- 200 MHz differential CPU clock pairs
- 100 MHz differential SRC clocks
- 48 MHz USB clock
- 33 MHz PCI clock
- 66 MHz HyperTransport[™] clock

- I²C support with readback capabilities
- Ideal Lexmark Spread Spectrum profile for maximum electromagnetic interference (EMI) reduction
- 3.3V power supply
- 56-pin SSOP and TSSOP packages

CPU	SRC	HTT66	PCI	REF	USB_48
x2	x8	x1	x1	x 3	x 1

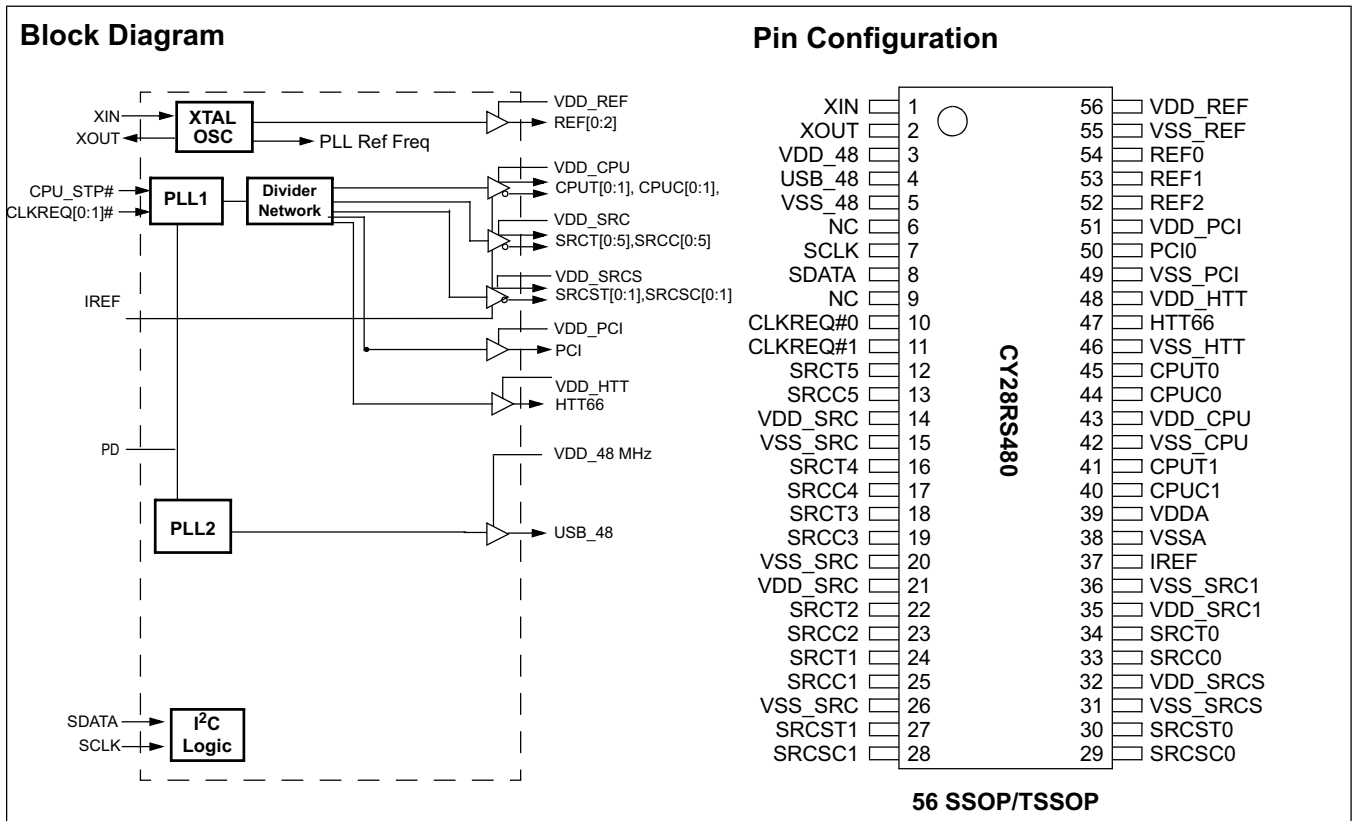

Pin Description

Pin No.	Name	Type	Description
41,40,45,44	CPUT/C	O, DIF	Differential CPU clock outputs. AMD K8 buffer (200 Mhz).
50	PCI0	O	33 MHz clock output.
37	IREF	I	A precision resistor attached to this pin is connected to the internal current reference.
52, 53, 54	REF[2:0]	O, SE	14.318 MHz REF clock output. Intel [®] Type-5 buffer.
7	SCLK	I,PU	SMBus-compatible SCLOCK. This pin has an internal pull-up, but is tri-stated in power-down.
8	SDATA	I/O,PU	SMBus-compatible SDATA. This pin has an internal pull-up, but is tri-stated in power-down.
27, 28, 30, 29	SRCST/C[1:0]	O, DIF	Differentials Selectable serial reference clock. Intel Type-X buffer. Includes overclock support through SMBUS
12, 13, 16, 17, 18, 19, 22, 23, 24, 25, 34, 33	SRCT/C[5:0]	O, DIF	100 MHz differential serial reference clock. Intel Type-X buffer.
10,11	CLKREQ#[0:1]	I, SE, PD	Output Enable control for SRCT/C. Output enable control required by Minicard specification. This pin has an internal pull-down. 0 = Selected SRC outputs are enabled, 1 = Selected SRC outputs are disabled
4	USB_48	O, SE	48 MHz clock output. Intel Type-3A buffer.
47	HTT66	O, SE	66 MHz clock output. Intel Type-5 buffer.
3	VDD_48	PWR	3.3V power supply for USB outputs
43	VDD_CPU	PWR	3.3V power supply for CPU outputs
51	VDD_PCI	PWR	3.3V power supply for PCI outputs
56	VDD_REF	PWR	3.3V power supply for REF outputs
48	VDD_HTT	PWR	3.3V power supply for Hyper Transport outputs
14, 21	VDD_SRC	PWR	3.3V power supply for SRC outputs
35	VDD_SRC1	PWR	3.3V power supply for SRC outputs
32	VDD_SRCs	PWR	3.3V power supply for SRCs outputs
39	VDDA	PWR	3.3V Analog Power for PLLs
5	VSS_48	GND	Ground for USB outputs
42	VSS_CPU	GND	Ground for CPU outputs
49	VSS_PCI	GND	Ground for PCI outputs
55	VSS_REF	GND	Ground for REF outputs
15, 20, 26	VSS_SRC	GND	Ground for SRC outputs
36	VSS_SRC1	GND	Ground for SRC outputs
31	VSS_SRCs	GND	Ground for SRCs outputs
46	VSS_HTT	GND	Ground for HyperTransport outputs
38	VSSA	GND	Analog Ground
1	XIN	I	14.318-MHz Crystal Input
2	XOUT	O	14.318-MHz Crystal Output
6, 9	NC		No Connects

Serial Data Interface

To enhance the flexibility and function of the clock synthesizer, a two-signal serial interface is provided. Through the Serial Data Interface, various device functions, such as individual clock output buffers, can be individually enabled or disabled. The registers associated with the Serial Data Interface initialize to their default setting upon power-up, and therefore use of this interface is optional. Clock device register changes are normally made upon system initialization, if any are required. The interface cannot be used during system operation for power management functions.

Data Protocol

The clock driver serial protocol accepts byte write, byte read, block write, and block read operations from the controller. For block write/read operation, the bytes must be accessed in sequential order from lowest to highest byte (most significant bit first) with the ability to stop after any complete byte has been transferred. For byte write and byte read operations, the system controller can access individually indexed bytes. The offset of the indexed byte is encoded in the command code, as described in *Table 1*.

The block write and block read protocol is outlined in *Table 2* while *Table 3* outlines the corresponding byte write and byte read protocol. The slave receiver address is 11010010 (D2h).

Table 1. Command Code Definition

Bit	Description
7	0 = Block read or block write operation, 1 = Byte read or byte write operation
(6:5)	Chip select address, set to '00' to access device
(4:0)	Byte offset for byte read or byte write operation. For block read or block write operations, these bits should be '00000'

Table 2. Block Read and Block Write Protocol

Block Write Protocol		Block Read Protocol	
Bit	Description	Bit	Description
1	Start	1	Start
8:2	Slave address – 7 bits	8:2	Slave address – 7 bits
9	Write	9	Write
10	Acknowledge from slave	10	Acknowledge from slave
18:11	Command Code – 8 bits	18:11	Command Code – 8 bits
19	Acknowledge from slave	19	Acknowledge from slave
27:20	Byte Count – 8 bits	20	Repeat start
28	Acknowledge from slave	27:21	Slave address – 7 bits
36:29	Data byte 1 – 8 bits	28	Read = 1
37	Acknowledge from slave	29	Acknowledge from slave
45:38	Data byte 2 – 8 bits	37:30	Byte Count from slave – 8 bits
46	Acknowledge from slave	38	Acknowledge
....	Data Byte /Slave Acknowledges	46:39	Data byte 1 from slave – 8 bits
....	Data Byte N – 8 bits	47	Acknowledge
....	Acknowledge from slave	55:48	Data byte 2 from slave – 8 bits
....	Stop	56	Acknowledge
		Data bytes from slave / Acknowledge
		Data Byte N from slave – 8 bits
		NOT Acknowledge

Table 3. Byte Read and Byte Write Protocol

Byte Write Protocol		Byte Read Protocol	
Bit	Description	Bit	Description
1	Start	1	Start
8:2	Slave address – 7 bits	8:2	Slave address – 7 bits
9	Write	9	Write
10	Acknowledge from slave	10	Acknowledge from slave

Table 3. Byte Read and Byte Write Protocol (continued)

Byte Write Protocol		Byte Read Protocol	
Bit	Description	Bit	Description
18:11	Command Code – 8 bits	18:11	Command Code – 8 bits
19	Acknowledge from slave	19	Acknowledge from slave
27:20	Data byte – 8 bits	20	Repeated start
28	Acknowledge from slave	27:21	Slave address – 7 bits
29	Stop	28	Read
		29	Acknowledge from slave
		37:30	Data from slave – 8 bits
		38	NOT Acknowledge
		39	Stop

Control Registers

Byte 0: Control Register 0

Bit	@Pup	Name	Description
7	1	SRC[T/C]5	SRC[T/C]5 Output Enable 0 = Disable (Hi-Z), 1 = Enable
6	1	SRC[T/C]4	SRC[T/C]4 Output Enable 0 = Disable (Hi-Z), 1 = Enable
5	1	SRC[T/C]3	SRC[T/C]3 Output Enable 0 = Disable (Hi-Z), 1 = Enable
4	1	SRC[T/C]2	SRC[T/C]2 Output Enable 0 = Disable (Hi-Z), 1 = Enable
3	1	SRC[T/C]1	SRC[T/C]1 Output Enable 0 = Disable (Hi-Z), 1 = Enable
2	1	SRC [T/C]0	SRC[T/C]0 Output Enable 0 = Disable (Hi-Z), 1 = Enable
1	1	SRCS[T/C]1	SRCS[T/C]1 Output Enable 0 = Disable (Hi-Z), 1 = Enable
0	1	SRCS[T/C]0	SRCS[T/C]0 Output Enable 0 = Disable (Hi-Z), 1 = Enable

Byte 1: Control Register 1

Bit	@Pup	Name	Description
7	1	REF2	REF2 Output Enable 0 = Disable, 1 = Enable
6	1	REF1	REF1 Output Enable 0 = Disable, 1 = Enable
5	1	REF0	REF0 Output Enable 0 = Disable, 1 = Enable
4	1	PCI0	PCI0 Output Enable 0 = Disable, 1 = Enable
3	1	USB_48	USB_48MHz Output Enable 0 = Disable, 1 = Enable
2	1	RESERVED	RESERVED
1	1	CPU[T/C]1	CPU[T/C]1 Output Enable 0 = Disable (Hi-Z), 1 = Enable
0	1	CPU[T/C]0	CPU[T/C]0 Output Enable 0 = Disable (Hi-Z), 1 = Enable

Byte 2: Control Register 2

Bit	@Pup	Name	Description
7	1	CPUT/C SRCT/C	Spread Spectrum Selection '0' = -0.35% '1' = -0.50%
6	1	USB_48	48-MHz Output Drive Strength 0 = 2x, 1 = 1x
5	1	PCI	33-MHz Output Drive Strength 0 = 2x, 1 = 1x
4	0	Reserved	Reserved
3	1	Reserved	Reserved
2	0	CPU SRC	CPU/SRC Spread Spectrum Enable 0 = Spread off, 1 = Spread on
1	1	Reserved	Reserved
0	1	Reserved	Reserved

Byte 3: Control Register 3

Bit	@Pup	Name	Description
7	1	CLKREQ#	CLKREQ# drive mode 0 = SRC clocks driven when stopped, 1 = SRC clocks tri-state when stopped
6	0	CPU	CPU pd drive mode 0 = CPU clocks driven when power-down, 1 = CPU clocks tri-state
5	1	SRC	SRC pd drive mode 0 = SRC clocks driven when power-down, 1 = SRC clocks tri-state
4	0	Reserved	Reserved
3	1	Reserved	Reserved
2	1	Reserved	Reserved
1	1	Reserved	Reserved
0	1	HTT66	HTT66 Output Drive Strength 0 = High drive, 1 = Low drive.

Byte 4: Control Register 4

Bit	@Pup	Name	Description
7	0	SRC[T/C]5	SRC[T/C]5 CLKREQ#0 control 1 = SRC[T/C]5 stoppable by CLKREQ#0 pin 0 = SRC[T/C]5 free running
6	0	SRC[T/C]4	SRC[T/C]4 CLKREQ#0 control 1 = SRC[T/C]4 stoppable by CLKREQ#0 pin 0 = SRC[T/C]4 free running
5	0	SRC[T/C]3	SRC[T/C]3 CLKREQ#0 control 1 = SRC[T/C]3 stoppable by CLKREQ#0 pin 0 = SRC[T/C]3 free running
4	0	SRC[T/C]2	SRC[T/C]2 CLKREQ#0 control 1 = SRC[T/C]2 stoppable by CLKREQ#0 pin 0 = SRC[T/C]2 free running
3	0	SRC[T/C]1	SRC[T/C]1 CLKREQ#0 control 1 = SRC[T/C]1 stoppable by CLKREQ#0 pin 0 = SRC[T/C]1 free running
2	0	SRC[T/C]0	SRC[T/C]0 CLKREQ#0 control 1 = SRC[T/C]0 stoppable by CLKREQ#0 pin 0 = SRC[T/C]0 free running
1	1	HTT66	HTT66 Output enable 0 = Disabled, 1 = Enabled

Byte 4: Control Register 4 (continued)

Bit	@Pup	Name	Description
0	1	Reserved	Reserved

Byte 5: Control Register 5

Bit	@Pup	Name	Description
7	0	SRC[T/C]5	SRC[T/C]5 CLKREQ#1 control 1 = SRC[T/C]5 stoppable by CLKREQ#1 pin 0 = SRC[T/C]5 free running
6	0	SRC[T/C]4	SRC[T/C]4 CLKREQ#1 control 1 = SRC[T/C]4 stoppable by CLKREQ#1 pin 0 = SRC[T/C]4 free running
5	0	SRC[T/C]3	SRC[T/C]3 CLKREQ#1 control 1 = SRC[T/C]3 stoppable by CLKREQ#1 pin 0 = SRC[T/C]3 free running
4	0	SRC[T/C]2	SRC[T/C]2 CLKREQ#1 control 1 = SRC[T/C]2 stoppable by CLKREQ#1 pin 0 = SRC[T/C]2 free running
3	0	SRC[T/C]1	SRC[T/C]1 CLKREQ#1 control 1 = SRC[T/C]1 stoppable by CLKREQ#1 pin 0 = SRC[T/C]1 free running
2	0	SRC[T/C]0	SRC[T/C]0 CLKREQ#1 control 1 = SRC[T/C]0 stoppable by CLKREQ#1 pin 0 = SRC[T/C]0 free running
1	0	Reserved	Reserved
0	0	Reserved	Reserved

Byte 6: Control Register 6

Bit	@Pup	Name	Description
7	0	TEST_SEL	REF/N or Three-state Select 1 = REF/N Clock, 0 = Three-state
6	0	TEST_MODE	Test Clock Mode Entry Control 1 = REF/N or Tri-state mode, 0 = Normal operation
5	0	REF	REF Output drive strength 0 = Low drive, 1 = High drive
4	1	Reserved	Reserved
3	HW	Reserved	Reserved
2	HW	Reserved	Reserved
1	HW	Reserved	Reserved
0	HW	Reserved	Reserved

Byte 7: Vendor ID

Bit	@Pup	Name	Description
7	0		Revision Code Bit 3
6	0		Revision Code Bit 2
5	0		Revision Code Bit 1
4	1		Revision Code Bit 0
3	1		Vendor ID Bit 3
2	0		Vendor ID Bit 2
1	0		Vendor ID Bit 1
0	0		Vendor ID Bit 0

Table 4. Crystal Recommendations

Frequency (Fund)	Cut	Loading	Load Cap	Drive (max.)	Shunt Cap (max.)	Motional (max.)	Tolerance (max.)	Stability (max.)	Aging (max.)
14.31818 MHz	AT	Parallel	20 pF	0.1 mW	5 pF	0.016 pF	35 ppm	30 ppm	5 ppm

Crystal Recommendations

The CY28RS480 requires a Parallel Resonance Crystal. Substituting a series resonance crystal will cause the CY28RS480 to operate at the wrong frequency and violate the ppm specification. For most applications there is a 300-ppm frequency shift between series and parallel crystals due to incorrect loading.

Crystal Loading

Crystal loading plays a critical role in achieving low ppm performance. To realize low ppm performance, the total capacitance the crystal will see must be considered to calculate the appropriate capacitive loading (CL).

Figure 1 shows a typical crystal configuration using the two trim capacitors. An important clarification for the following discussion is that the trim capacitors are in series with the crystal not parallel. It's a common misconception that load capacitors are in parallel with the crystal and should be approximately equal to the load capacitance of the crystal. This is not true.

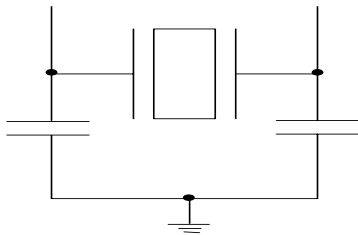
Figure 1. Crystal Capacitive Clarification

Calculating Load Capacitors

In addition to the standard external trim capacitors, trace capacitance and pin capacitance must also be considered to correctly calculate crystal loading. As mentioned previously, the capacitance on each side of the crystal is in series with the crystal. This means the total capacitance on each side of the crystal must be twice the specified crystal load capacitance (CL). While the capacitance on each side of the crystal is in

series with the crystal, trim capacitors (Ce1,Ce2) should be calculated to provide equal capacitive loading on both sides.

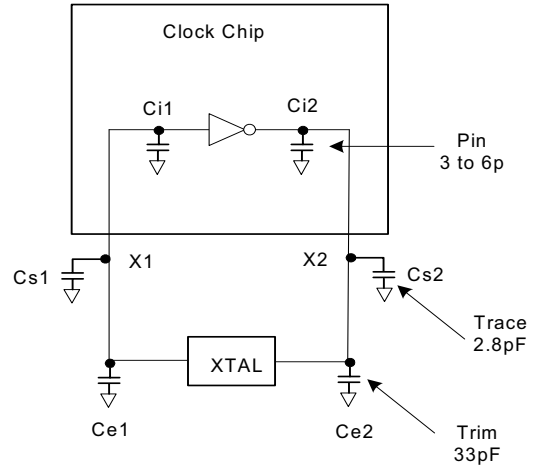
Figure 2. Crystal Loading Example

As mentioned previously, the capacitance on each side of the crystal is in series with the crystal. This means the total capacitance on each side of the crystal must be twice the specified load capacitance (CL). While the capacitance on each side of the crystal is in series with the crystal, trim capacitors (Ce1,Ce2) should be calculated to provide equal capacitance loading on both sides.

Use the following formulas to calculate the trim capacitor values for Ce1 and Ce2.

Load Capacitance (each side)

$$C_e = 2 * CL - (C_s + C_i)$$

Total Capacitance (as seen by the crystal)

$$CL_e = \frac{1}{\left(\frac{1}{C_{e1} + C_{s1} + C_{i1}} + \frac{1}{C_{e2} + C_{s2} + C_{i2}} \right)}$$

- CL.....Crystal load capacitance
- CL_e..... Actual loading seen by crystal using standard value trim capacitors
- C_e..... External trim capacitors
- C_s..... Stray capacitance (terraced)
- C_i Internal capacitance (lead frame, bond wires etc.)
- CL.....Crystal load capacitance
- CL_e..... Actual loading seen by crystal using standard value trim capacitors
- C_e..... External trim capacitors
- C_s..... Stray capacitance (terraced)
- C_i Internal capacitance (lead frame, bond wires etc.)

CLK_REQ[0:1]# Description

The CLKREQ#[1:0] signals are active low input used for clean stopping and starting selected SRC outputs. The outputs controlled by CLKREQ#[1:0] are determined by the settings in register bytes 4 and 5. The CLKREQ# signal is a debounced signal in that its state must remain unchanged during two consecutive rising edges of DIFC to be recognized as a valid assertion or deassertion. (The assertion and deassertion of this signal is absolutely asynchronous.)

CLK_REQ[0:1]# Deassertion [Low to High Transition]

The impact of deasserting the CLKREQ#[1:0] pins is all DIF outputs that are set in the control registers to stoppable via assertion of CLKREQ#[1:0] are to be stopped after their next transition. When the control register CLKREQ# drive mode bit is programmed to '0', the final state of all stopped SRC signals

is SRCT clock = High and SRCC = Low. There is to be no change to the output drive current values, SRCT will be driven high with a current value equal $6 \times I_{ref}$. When the control register CLKREQ# drive mode bit is programmed to '1', the final state of all stopped DIF signals is low, both SRCT clock and SRCC clock outputs will not be driven.

CLK_REQ[0:1]# Assertion [High to Low Transition]

All differential outputs that were stopped are to resume normal operation in a glitch free manner. The maximum latency from the Assertion to active outputs is between 2–6 SRC clock periods (2 clocks are shown) with all SRC outputs resuming simultaneously. If the CLKREQ# drive mode bit is programmed to '1' three-state), the all stopped SRC outputs must be driven high within 10 ns of CLKREQ#[1:0] Assertion to a voltage greater than 200 mV.

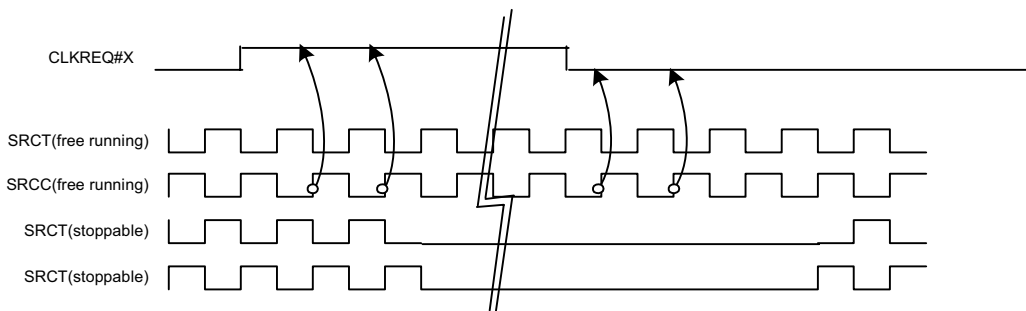

Figure 3. CLK_REQ#[0:1] Assertion/Deassertion Waveform

Absolute Maximum Conditions

Parameter	Description	Condition	Min.	Max.	Unit
V _{DD}	Core Supply Voltage		-0.5	4.6	V
V _{DDA}	Analog Supply Voltage		-0.5	4.6	V
V _{IN}	Input Voltage	Relative to V _{SS}	-0.5	V _{DD} +0.5	VDC
T _S	Temperature, Storage	Non-functional	-65	+150	°C
T _A	Temperature, Operating Ambient	Functional	0	70	°C
T _J	Temperature, Junction	Functional	-	150	°C
ESD _{HBM}	ESD Protection (Human Body Model)	MIL-STD-883, Method 3015	2000	-	V
∅ _{JC}	Dissipation, Junction to Case	Mil-Spec 883E Method 1012.1	-	20	°C/W
∅ _{JA}	Dissipation, Junction to Ambient	JEDEC (JESD 51)	-	60	°C/W
UL-94	Flammability Rating	At 1/8 in.	V-0		
MSL	Moisture Sensitivity Level		1		

Multiple Supplies: The voltage on any input or I/O pin cannot exceed the power pin during power-up. Power supply sequencing is NOT required.

DC Electrical Specifications

Parameter	Description	Condition	Min.	Max.	Unit
V _{DD_REF} , V _{DD_CPU} , V _{DD_PCI} , V _{DD_SRC} , V _{DD_SRC1} , V _{DD_SRC5} , V _{DD_48}	3.3V Operating Voltage	3.3V ± 5%	3.135	3.465	V
V _{ILSMBUS}	Input Low Voltage	SDATA, SCLK	-	1.0	V
V _{IHSMBUS}	Input High Voltage	SDATA, SCLK	2.2	-	V
V _{IL}	Input Low Voltage	V _{DD}	V _{SS} -0.3	0.8	V
V _{IH}	Input High Voltage		2.0	V _{DD} +0.3	V
I _{IL}	Input Leakage Current	Except pull-ups or pull-downs 0<V _{IN} <V _{DD}	-5	5	mA
V _{OL}	Output Low Voltage	I _{OL} = 1 mA	-	0.4	V
V _{OH}	Output High Voltage	I _{OH} = 1 mA	2.4	-	V
I _{OZ}	High-Impedance Output Current		-10	10	μA
C _{IN}	Input Pin Capacitance		3	5	pF
C _{OUT}	Output Pin Capacitance		3	5	pF
L _{IN}	Pin Inductance		-	7	nH
V _{XIH}	Xin High Voltage		0.7*V _{DD}	V _{DD}	V
V _{XIL}	Xin Low Voltage		0	0.3*V _{DD}	V
I _{DD}	Dynamic Supply Current	At max load and frequency	-	450	mA
IPD _D	Power Down Supply Current	PD asserted, Outputs driven	-	75	mA
IPD _T	Power Down Supply Current	PD asserted, Outputs Hi-Z	-	12	mA

AC Electrical Specifications

Parameter	Description	Condition	Min.	Max.	Unit
Crystal					
T _{DC}	XIN Duty Cycle	The device will operate reliably with input duty cycles up to 30/70 but the REF clock duty cycle will not be within specification	47.5	52.5	%
T _{PERIOD}	XIN Period	When XIN is driven from an external clock source	69.841	71.0	ns
T _R / T _F	XIN Rise and Fall Times	Measured between 0.3V _{DD} and 0.7V _{DD}	–	10.0	ns
T _{CCJ}	XIN Cycle to Cycle Jitter	As an average over 1-μs duration	–	500	ps
L _{ACC}	Long-term Accuracy	Over 150 ms	–	300	ppm
CPU Outputs					
T _R /T _F	Output Slew Rate	Measured @ test load using VO _{CM} ±400 mV, 0.85 to 1.65	2	7	V/ns
V _{DIFF}	Differential Voltage	Measured at load single ended	0.4	2.3	V
T _{SKEW}	Any CPU to CPU Clock Skew	Measured at crossing point V _{OX}	–	250	ps
_ V _{DIFF}	Change in V _{DIFF} _DC Magnitude	Measured at load single ended	–150	150	mV
V _{CM}	Common Mode Voltage	Measured at load single ended	1.05	1.45	V
_ V _{CM}	Change in V _{CM}	Measured at load single ended	–200	200	mV
T _{DC}	Duty Cycle	Measured at V _{OX}	45	55	%
T _{JCYC}	Cycle to Cycle Jitter	Measured at V _{OX}	0	200	ps
SRC					
T _{DC}	SRCT and SRCC Duty Cycle	Measured at crossing point V _{OX}	45	55	%
T _{PERIOD}	100-MHz SRCT and SRCC Period	Measured at crossing point V _{OX}	9.997001	10.00300	ns
T _{PERIODSS}	100-MHz SRCT and SRCC Period, SSC	Measured at crossing point V _{OX}	9.997001	10.05327	ns
T _{PERIODAbs}	100-MHz SRCT and SRCC Absolute Period	Measured at crossing point V _{OX}	10.12800	9.872001	ns
T _{PERIODSSAbs}	100-MHz SRCT and SRCC Absolute Period, SSC	Measured at crossing point V _{OX}	9.872001	10.17827	ns
T _{SKEW}	Any SRCT/C to SRCT/C Clock Skew	Measured at crossing point V _{OX}	–	250	ps
T _{SKEW}	Any SRCS clock to Any SRCS clock Skew	Measured at crossing point V _{OX}	–	250	ps
T _{CCJ}	SRCT/C Cycle to Cycle Jitter	Measured at crossing point V _{OX}	–	125	ps
L _{ACC}	SRCT/C Long Term Accuracy	Measured at crossing point V _{OX}	–	300	ppm
T _R / T _F	SRCT and SRCC Rise and Fall Times	Measured from V _{OL} = 0.175 to V _{OH} = 0.525V	175	700	ps
T _{RFM}	Rise/Fall Matching	Determined as a fraction of 2*(T _R – T _F)/(T _R + T _F)	–	20	%
ΔT _R	Rise Time Variation		–	125	ps
ΔT _F	Fall Time Variation		–	125	ps
V _{HIGH}	Voltage High	Math averages <i>Figure 5</i>	660	850	mv
V _{LOW}	Voltage Low	Math averages <i>Figure 5</i>	–150	–	mv
V _{OX}	Crossing Point Voltage at 0.7V Swing		250	550	mV
V _{OVS}	Maximum Overshoot Voltage		–	V _{HIGH} + 0.3	V
V _{UDS}	Minimum Undershoot Voltage		–0.3	–	V
V _{RB}	Ring Back Voltage	See <i>Figure 5</i> . Measure SE	–	0.2	V
HTT66 HyperTransport Output					
F66	Operating Frequency		–	66.67	MHz

AC Electrical Specifications (continued)

Parameter	Description	Condition	Min.	Max.	Unit
TDC	Duty Cycle	Measured at 1.5V	45	55	%
TR/TF	Slew Rate	Measured at 20% and 60%	0.9	6.5	V/ns
TCCJ	Cycle to Cycle jitter	Measured at 1.5V	–	450	ps
TSKEW	HTT66 clock to PCI clock Skew	Measurement at 1.5V	–	500	ps
PCI					
T _{DC}	PCI Duty Cycle	Measurement at 1.5V	45	55	%
T _{PERIOD}	Spread Disabled PCI Period	Measurement at 1.5V	29.99100	30.00900	ns
T _{PERIODSS}	Spread Enabled PCI Period, SSC	Measurement at 1.5V	29.9910	30.15980	ns
T _{PERIODAbs}	Spread Disabled PCI Period	Measurement at 1.5V	29.49100	30.50900	ns
T _{PERIODSSAbs}	Spread Enabled PCI Period, SSC	Measurement at 1.5V	29.49100	30.65980	ns
T _{HIGH}	PCI high time	Measurement at 2.4V	12.0	–	ns
T _{LOW}	PCI low time	Measurement at 0.4V	12.0	–	ns
T _R / T _F	PCI rise and fall times	Measured between 0.8V and 2.0V	1.0	4.0	V/ns
T _{CCJ}	PCI Cycle to Cycle Jitter	Measurement at 1.5V	–	500	ps
USB					
T _{DC}	Duty Cycle	Measurement at 1.5V	45	55	%
T _{PERIOD}	Period	Measurement at 1.5V	20.83125	20.83542	ns
T _{PERIODAbs}	Absolute Period	Measurement at 1.5V	20.48125	21.18542	ns
T _{HIGH}	USB high time	Measurement at 2.4V	8.094	10.036	ns
T _{LOW}	USB low time	Measurement at 0.4V	7.694	9.836	ns
T _R / T _F	Rise and Fall Times	Measured between 0.8V and 2.0V	1.0	2.0	V/ns
T _{CCJ}	Cycle to Cycle Jitter	Measurement at 1.5V	–	350	ps
TLTJ	Long Term Jitter	Measurement at 1.5V@1 us	–	TBD	ps
REF					
T _{DC}	REF Duty Cycle	Measurement at 1.5V	45	55	%
T _{PERIOD}	REF Period	Measurement at 1.5V	69.8203	69.8622	ns
T _{PERIODAbs}	REF Absolute Period	Measurement at 1.5V	68.82033	70.86224	ns
T _R / T _F	REF Rise and Fall Times	Measured between 0.8V and 2.0V	1.0	4.0	V/ns
T _{CCJ}	REF Cycle to Cycle Jitter	Measurement at 1.5V	–	1000	ps
ENABLE/DISABLE and SET-UP					
T _{STABLE}	Clock Stabilization from Power-up		–	1.8	ms
T _{SS}	Stopclock Set-up Time		10.0	–	ns
T _{SH}	Stopclock Hold Time		0	–	ns

Test and Measurement Set-up

For PCI Single-ended Signals and Reference

The following diagram shows the test load configurations for the single-ended PCI, USB, and REF output signals.

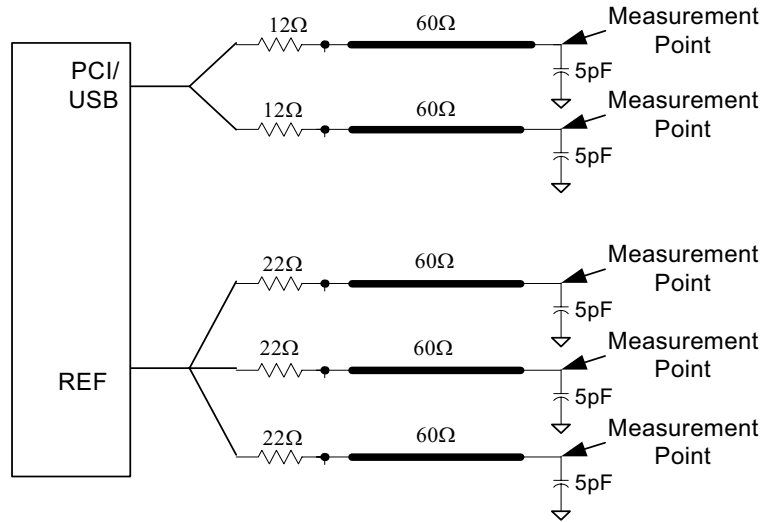

Figure 4. Single-ended Load Configuration

For Differential CPU and SRC Output Signals

The following diagram shows the test load configuration for the differential SRC outputs.

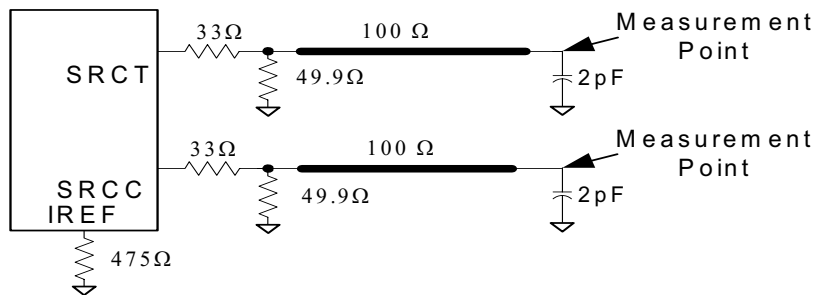

Figure 5. 0.7V Load Configuration

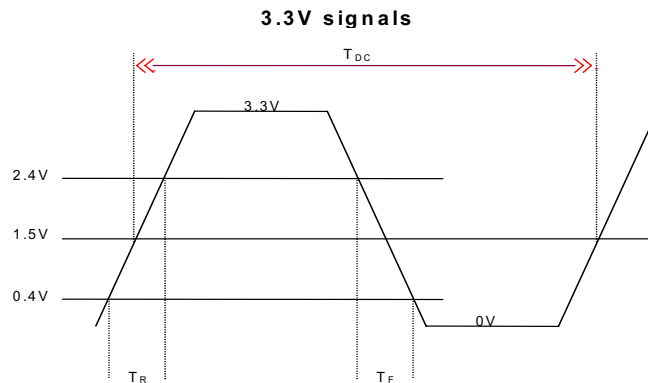
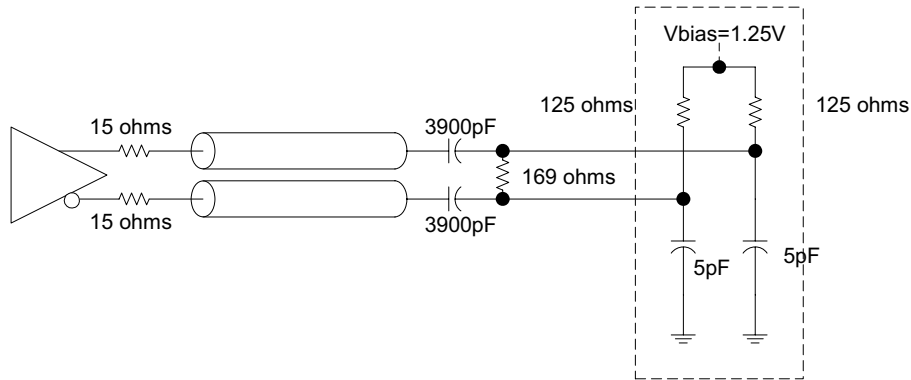
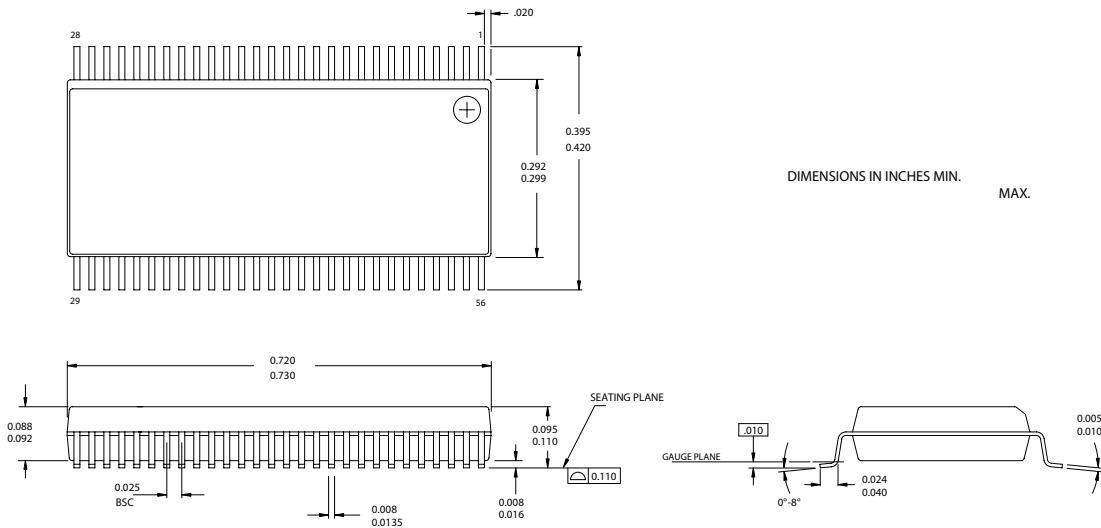
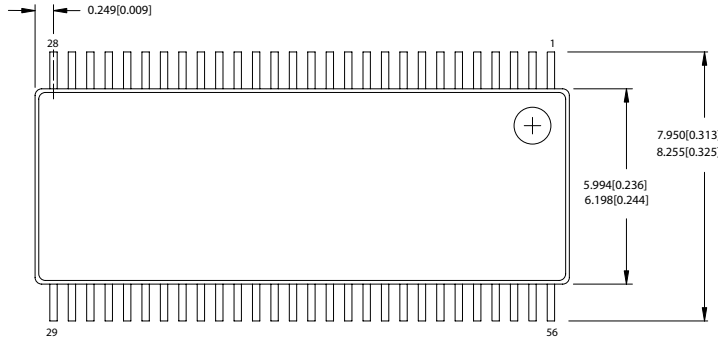

Figure 6. Single-ended Output Signals (for AC Parameters Measurement)

Figure 7. CPU Output Load Configuration
Ordering Information

Part Number	Package Type	Product Flow
Lead-free		
CY28RS480OXC	56-pin SSOP	Commercial, 0° to 70°C
CY28RS480OXCT	56-pin SSOP – Tape and Reel	Commercial, 0° to 70°C
CY28RS480ZXC	56-pin TSSOP	Commercial, 0° to 70°C
CY28RS480ZXCT	56-pin TSSOP – Tape and Reel	Commercial, 0° to 70°C

Package Drawing and Dimensions
56-Lead Shrunken Small Outline Package O56

Package Drawing and Dimensions (continued)
56-Lead Thin Shrunken Small Outline Package, Type II (6 mm x 12 mm) Z56

DIMENSIONS IN MM [INCHES] MIN. MAX.

REFERENCE JEDEC MO-153

PACKAGE WEIGHT 0.42gms

PART #
Z5624 STANDARD PKG.
ZZ5624 LEAD FREE PKG.

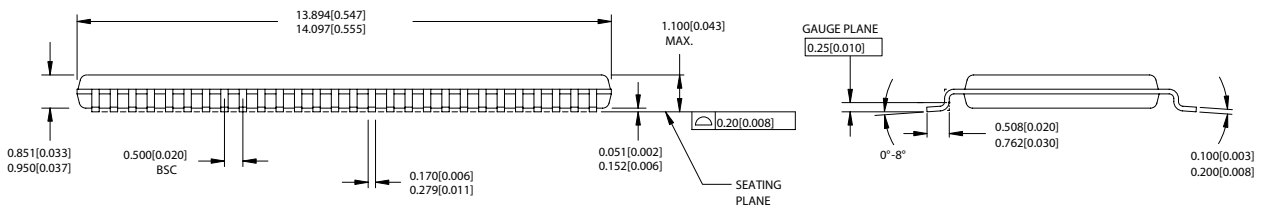

While SLI has reviewed all information herein for accuracy and reliability, Spectra Linear Inc. assumes no responsibility for the use of any circuitry or for the infringement of any patents or other rights of third parties which would result from each use. This product is intended for use in normal commercial applications and is not warranted nor is it intended for use in life support, critical medical instruments, or any other application requiring extended temperature range, high reliability, or any other extraordinary environmental requirements unless pursuant to additional processing by Spectra Linear Inc., and expressed written agreement by Spectra Linear Inc. Spectra Linear Inc. reserves the right to change any circuitry or specification without notice.