

PRELIMINARY SPEC

Part Number: APBDA3020SURKCGKC

Hyper Red
Green

Features

- 3.0mmx2.0mm SMT LED, 2.8mm THICKNESS.
- LOW POWER CONSUMPTION.
- VARIOUS COLORS AND LENS TYPES AVAILABLE.
- IDEAL FOR BACK LIGHT AND INDICATOR
- PACKAGE : 2000PCS / REEL.
- WHEN SOLDERED IN THE SIDEVIEW CONFIGURATION, THE MAXIMUM SHEAR TOLERANCE OF THE EPOXY LENS IS 300G.
- MOISTURE SENSITIVITY LEVEL : LEVEL 3.
- RoHS COMPLIANT

Description

The Hyper Red source color devices are made with DH InGaAlP on GaAs substrate Light Emitting Diode. The Green source color devices are made with InGaAlP on GaAs substrate Light Emitting Diode.

Package Dimensions

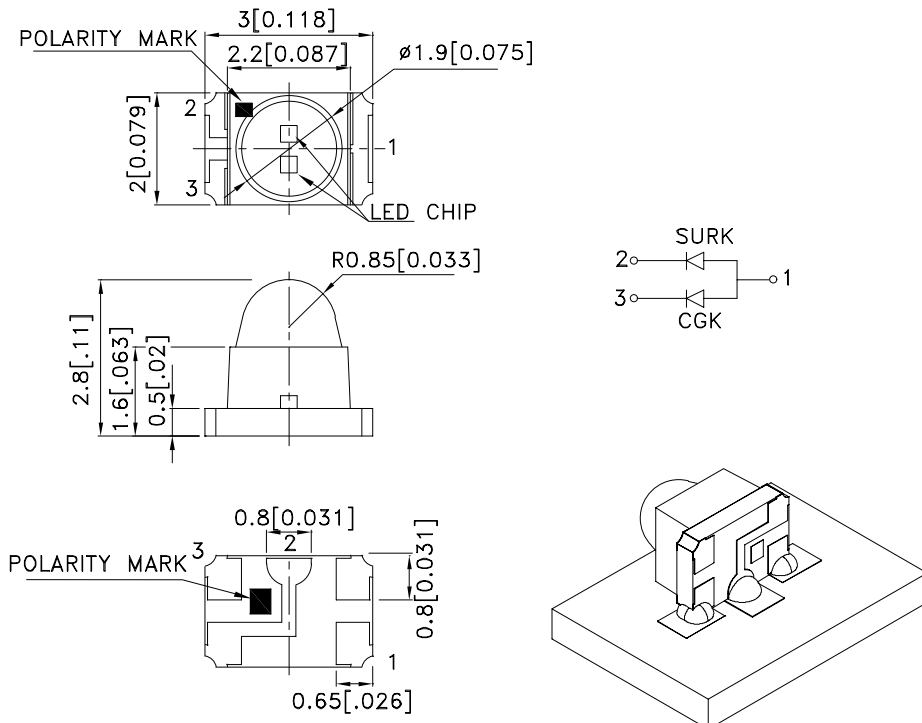

Notes:

1. All dimensions are in millimeters (inches).
2. Tolerance is ± 0.2 (0.008") unless otherwise noted.
3. Specifications are subject to change without notice.
4. The device has a single mounting surface. The device must be mounted according to the specifications.



Selection Guide

Part No.	Dice	Lens Type	Iv (mcd) [2] @ 20mA		Viewing Angle [1]
			Min.	Typ.	2θ1/2
APBDA3020SURKCGKC	Hyper Red (InGaAlP)	WATER CLEAR	650	900	15°
	Green (InGaAlP)		180	320	

Notes:

1. θ1/2 is the angle from optical centerline where the luminous intensity is 1/2 the optical centerline value.
2. Luminous intensity/ luminous Flux: +/-15%.

Electrical / Optical Characteristics at TA=25°C

Symbol	Parameter	Device	Typ.	Max.	Units	Test Conditions
λ _{peak}	Peak Wavelength	Hyper Red Green	650 574		nm	I _F =20mA
λ _D [1]	Dominant Wavelength	Hyper Red Green	635 570		nm	I _F =20mA
Δλ _{1/2}	Spectral Line Half-width	Hyper Red Green	28 20		nm	I _F =20mA
C	Capacitance	Hyper Red Green	35 15		pF	V _F =0V;f=1MHz
V _F [2]	Forward Voltage	Hyper Red Green	1.95 2.1	2.5 2.5	V	I _F =20mA
I _R	Reverse Current	Hyper Red Green		10 10	μA	V _R = 5V

Notes:

1. Wavelength: +/-1nm.
2. Forward Voltage: +/-0.1V.

Absolute Maximum Ratings at TA=25°C

Parameter	Hyper Red	Green	Units
Power dissipation	75	75	mW
DC Forward Current	30	30	mA
Peak Forward Current [1]	185	150	mA
Reverse Voltage	5		V
Operating Temperature	-40°C To +85°C		
Storage Temperature	-40°C To +85°C		

Note:

1. 1/10 Duty Cycle, 0.1ms Pulse Width.

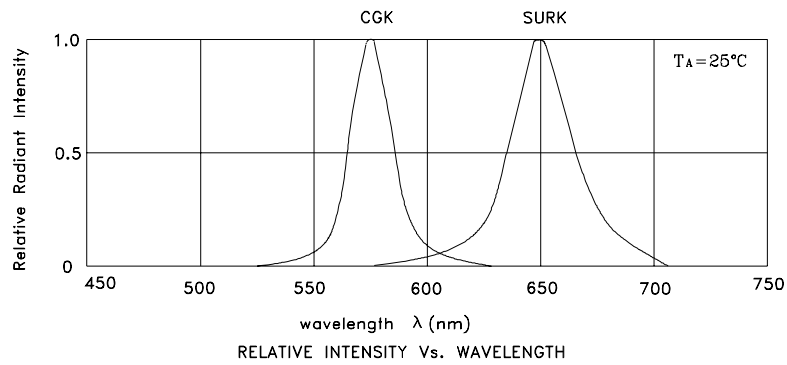

APBDA3020SURKCGKC
Hyper Red

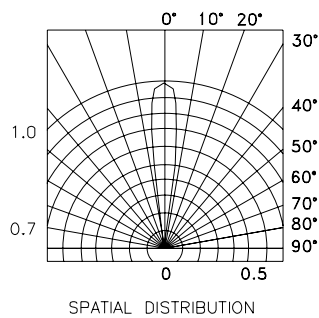
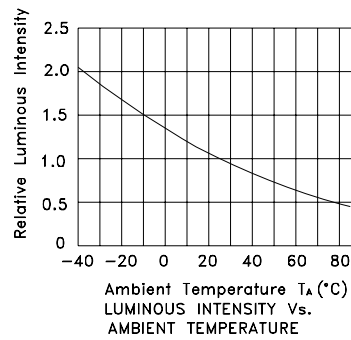
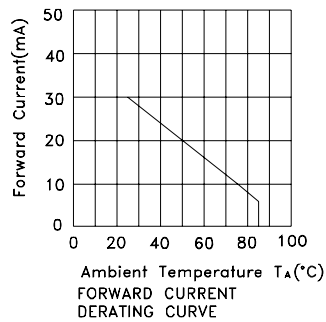
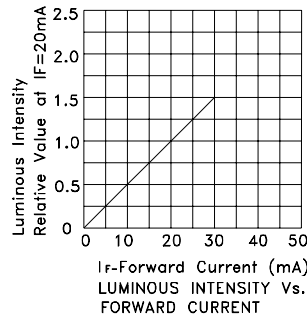
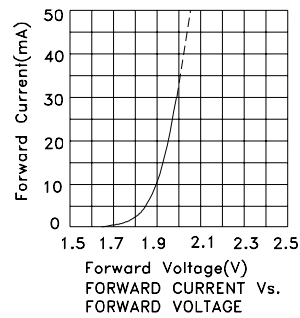

Green

