

LF Transmitter Antenna AS4112



Description

- Compact LF transmitter antenna.
- Installation space can be saved.
- L × W × H: 43.4 × 12 × 15 mm
- Product weight: 7.5 g (harness excluded).
- Waterproof level: IPX6.
- Pre-set resonant frequency to 125kHz, 134.2kHz or customization.
- Reference electric field: 98 μ V/m@3m (@ 134.2kHz, 1.4App)
- Resin potted, with/without connector.
- RoHS compliance.

Environmental Data

- Operating temperature range: -40°C~+85°C
- Storage temperature range: -40°C~+85°C

Packaging

- Plastic tray and carton box.
- Carton dimension: 500 × 300 × 195mm.
- 90pcs/box.

Applications

- PEPS, Smart key system.
- Security system

Dimension - [mm]

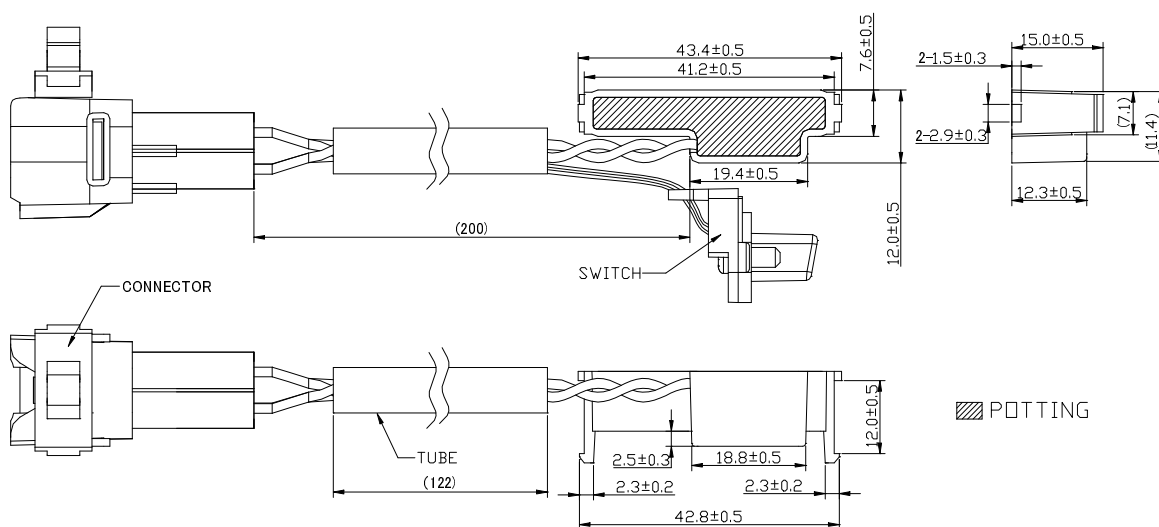

* The dimensions without tolerance are reference values.

LF Transmitter Antenna AS4112

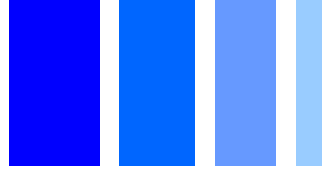

Electrical Characteristics

Part number	Tuning capacitance	Resonant frequency	Resonant current	Load resistance
AS4112 -125-332	3 . 3 n F	125.0±1.5kHz	1.0App	4. 7 Ω
AS4112 -134-332	3 . 3 n F	134.2±1.5kHz	1.2App	4. 7 Ω
AS4112 -125-472	4 . 7 n F	125.0±1.5kHz	1.2App	6. 8 Ω
AS4112 -134-472	4 . 7 n F	134.2±1.5kHz	1.3App	6. 8 Ω

For more information, please browse our website <http://www.sumida.com>

Hong Kong

Tel.+852-2880-6688
FAX.+852-2565-9600

Tokyo

Tel.+81-3-5202-7112
FAX.+81-3-5202-7105

Chicago

Tel.+1-847-545-6700
FAX. +1-847-545-6720

Shanghai

Tel.+86-021-5836-3299
FAX.+86-021-5836-3266

Seoul

Tel.+82-2-6237-0777
FAX.+82-2-6237-0778

Oberzell

Tel.+49-8591-937-0
FAX. +49-8591-937-103

Shenzhen

Tel.+86-755-8291-0228
FAX.+86-755-8291-0338

Singapore

Tel.+65-6296-3388
FAX.+65-6296-3390

Neumarkt

Tel.+49-9181-4509-110
FAX. +49-9181-4509-310

Taipei

Tel.+886-2-8751-2737
FAX.+886-2-8751-2738

San Jose

Tel.+1-408-321-9660
FAX.+1-408-321-9308