

Bicolor SMD LED PLCC-4

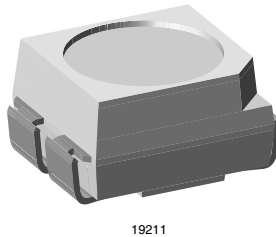

19211

DESCRIPTION

These devices have been designed to meet the increasing demand for surface mounting technology.

The package of the VLMSY3420 is the PLCC-4.

It consists of a lead frame which is embedded in a white thermoplast. The reflector inside this package is filled up with clear epoxy.

This SMD device consists of a red and yellow chip. So it is possible to choose the color in one device.

PRODUCT GROUP AND PACKAGE DATA

- Product group: LED
- Package: SMD PLCC-4
- Product series: bicolor
- Angle of half intensity: $\pm 60^\circ$

PARTS TABLE		
PART	COLOR, LUMINOUS INTENSITY	TECHNOLOGY
VLMSY3420-GS08	Red, $I_V = (224 \text{ to } 900) \text{ mcd}$ Yellow, $I_V = (280 \text{ to } 1120) \text{ mcd}$	AllInGaP on GaAs
VLMSY3420-GS18	Red, $I_V = (224 \text{ to } 900) \text{ mcd}$ Yellow, $I_V = (280 \text{ to } 1120) \text{ mcd}$	AllInGaP on GaAs

FEATURES

- SMD LED with exceptional brightness
- Multicolored
- Luminous intensity categorized
- EIA and ICE standard package
- Compatible with automatic placement equipment
- Compatible with IR reflow, vapor phase and wave soldering processes according to CECC 00802 and J-STD-020C
- Available in 8 mm tape
- Low profile package
- Non-diffused lens: excellent for coupling to light pipes and backlighting
- Low power consumption
- Luminous intensity ratio in one packaging unit
 $I_{Vmax}/I_{Vmin} \leq 1.6$
- Lead (Pb)-free device
- Preconditioning: according to JEDEC level 2a
- Component in accordance to RoHS 2002/95/EC and WEEE 2002/96/EC
- ESD-withstand voltage: up to 2 kV according to JESD22-A114-B
- Automotive qualified AEC-Q101



APPLICATIONS

- Automotive: backlighting in dashboards and switches
- Telecommunication: indicator and backlighting in telephone and fax
- Indicator and backlight in office equipment
- Flat backlight for LCDs, switches and symbols
- General use

ABSOLUTE MAXIMUM RATINGS ¹⁾ VLMSY3420					
PARAMETER	TEST CONDITION		SYMBOL	VALUE	UNIT
Reverse voltage per diode ²⁾	$I_R = 10 \mu\text{A}$		V_R	5	V
DC Forward current per diode	$T_{\text{amb}} \leq 65 \text{ }^\circ\text{C}$		I_F	50	mA
Surge forward current per diode			I_{FSM}	0.1	A
Power dissipation per diode			P_V	130	mW
Junction temperature			T_j	125	$^\circ\text{C}$
Operating temperature range			T_{amb}	- 40 to + 100	$^\circ\text{C}$
Storage temperature range			T_{stg}	- 40 to + 100	$^\circ\text{C}$
Thermal resistance junction/ ambient	mounted on PC board (pad size > 16 mm ²)	1 chip on	R_{thJA}	480	K/W
		2 chips on		650	

Note:

1) $T_{\text{amb}} = 25 \text{ }^\circ\text{C}$, unless otherwise specified

2) Driving the LED in reverse direction is suitable for short term application

OPTICAL AND ELECTRICAL CHARACTERISTICS ¹⁾ VLMSY3420, SUPERRED							
PARAMETER	TEST CONDITION	PART	SYMBOL	MIN.	TYP.	MAX.	UNIT
Luminous intensity	$I_F = 50 \text{ mA}$	VLMSY3420	I_V	224		900	mcd
Dominant wavelength	$I_F = 50 \text{ mA}$		λ_d		630		nm
Peak wavelength	$I_F = 50 \text{ mA}$		λ_p		643		nm
Angle of half intensity	$I_F = 50 \text{ mA}$		ϕ		± 60		deg
Forward voltage	$I_F = 50 \text{ mA}$		V_F		2.1	2.6	V
Reverse current	$V_R = 5 \text{ V}$,		I_R			10	μA
Junction capacitance	$V_R = 0 \text{ V}$, $f = 1 \text{ MHz}$		C_j		15		pF

Note:

1) $T_{\text{amb}} = 25 \text{ }^\circ\text{C}$, unless otherwise specified

OPTICAL AND ELECTRICAL CHARACTERISTICS ¹⁾ VLMSY3420, YELLOW							
PARAMETER	TEST CONDITION	PART	SYMBOL	MIN.	TYP.	MAX.	UNIT
Luminous intensity	$I_F = 50 \text{ mA}$	VLMSY3420	I_V	280		1120	mcd
Dominant wavelength	$I_F = 50 \text{ mA}$		λ_d	581	588	594	nm
Peak wavelength	$I_F = 50 \text{ mA}$		λ_p		590		nm
Angle of half intensity	$I_F = 50 \text{ mA}$		ϕ		± 60		deg
Forward voltage	$I_F = 50 \text{ mA}$		V_F		2.1	2.6	V
Reverse current	$V_R = 5 \text{ V}$,		I_R			10	μA
Junction capacitance	$V_R = 0 \text{ V}$, $f = 1 \text{ MHz}$		C_j		15		pF

Note:

1) $T_{\text{amb}} = 25 \text{ }^\circ\text{C}$, unless otherwise specified

LUMINOUS INTENSITY CLASSIFICATION AND GROUP COMBINATIONS ¹⁾ VLMSY3420							
		RED					
		S2 224 to 280 mcd	T1 280 to 355 mcd	T2 355 to 450 mcd	U1 450 to 560 mcd	U2 560 to 710 mcd	V1 710 to 900 mcd
Y E L L O W	T1 280 to 355 mcd	VLMSY3420	VLMSY3420	VLMSY3420	VLMSY3420	VLMSY3420	VLMSY3420
	T2 355 to 450 mcd	VLMSY3420	VLMSY3420	VLMSY3420	VLMSY3420	VLMSY3420	VLMSY3420
	U1 450 to 560 mcd	VLMSY3420	VLMSY3420	VLMSY3420	VLMSY3420	VLMSY3420	VLMSY3420
	U2 560 to 710 mcd	VLMSY3420	VLMSY3420	VLMSY3420	VLMSY3420	VLMSY3420	VLMSY3420
	V1 710 to 900 mcd	VLMSY3420	VLMSY3420	VLMSY3420	VLMSY3420	VLMSY3420	VLMSY3420
	V2 900 to 1120 mcd	VLMSY3420	VLMSY3420	VLMSY3420	VLMSY3420	VLMSY3420	VLMSY3420

Note:

¹⁾ Luminous intensity is tested at a current pulse duration of 25 ms and an accuracy of $\pm 11\%$

COLOR CLASSIFICATION			
GROUP	DOMINANT WAVELENGTH (nm)		
	YELLOW		
	MIN.	MAX.	
1	581	584	
2	583	586	
3	585	588	
4	587	590	
5	589	592	
6	591	594	

TYPICAL CHARACTERISTICS

$T_{amb} = 25\text{ }^{\circ}\text{C}$, unless otherwise specified

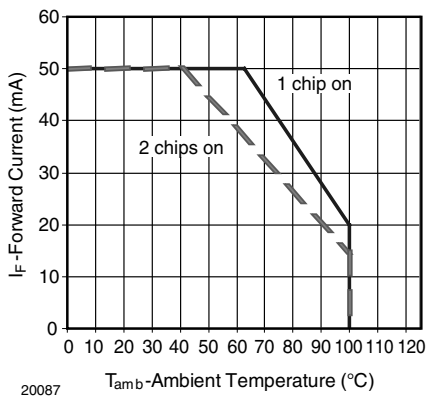

Figure 1. Forward Current vs. Ambient Temperature for InGaN

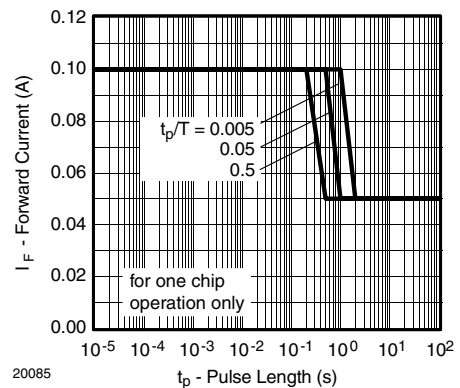

Figure 2. Forward Current vs. Pulse Duration

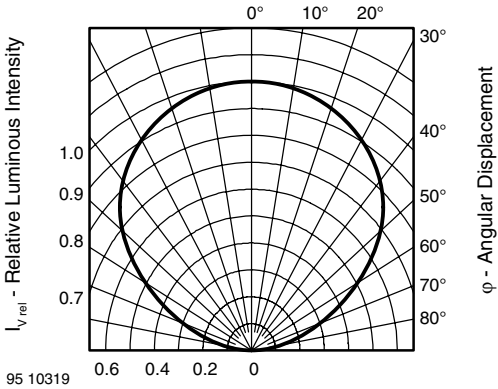

Figure 3. Rel. Luminous Intensity vs. Angular Displacement

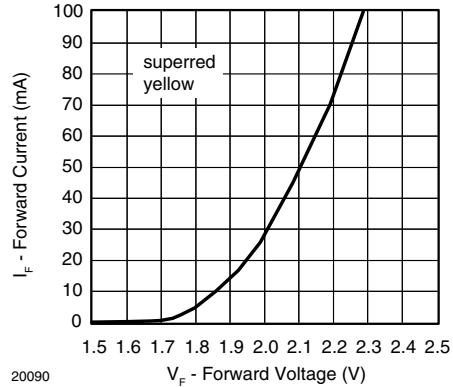

Figure 6. Relative Forward Voltage vs. Ambient Temperature

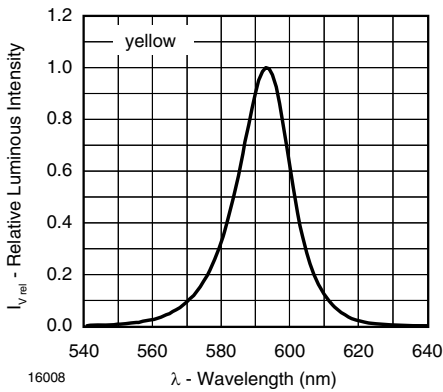

Figure 4. Relative Intensity vs. Wavelength

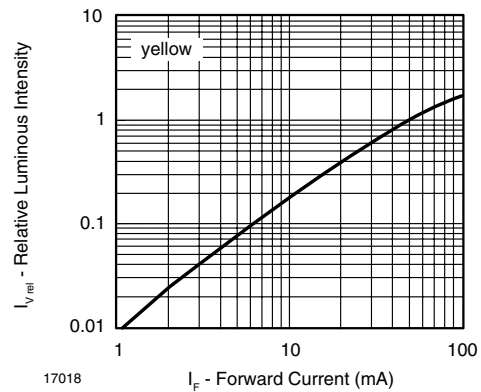

Figure 7. Relative Luminous Intensity vs. Forward Current

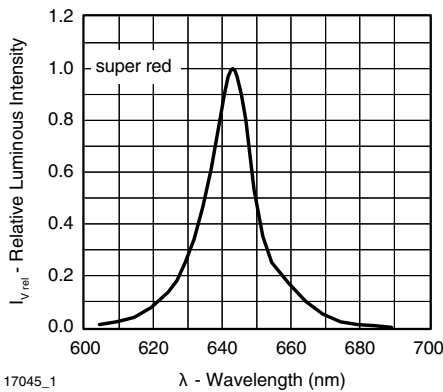

Figure 5. Relative Intensity vs. Wavelength

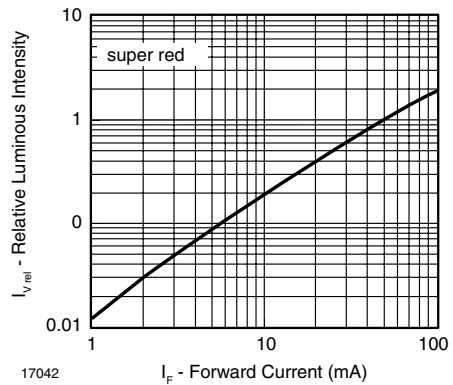

Figure 8. Relative Luminous Intensity vs. Forward Current

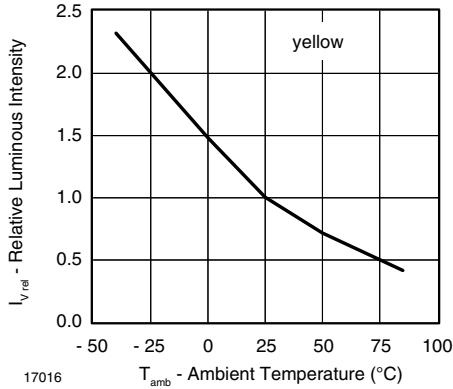

Figure 9. Rel. Luminous Intensity vs. Ambient Temperature

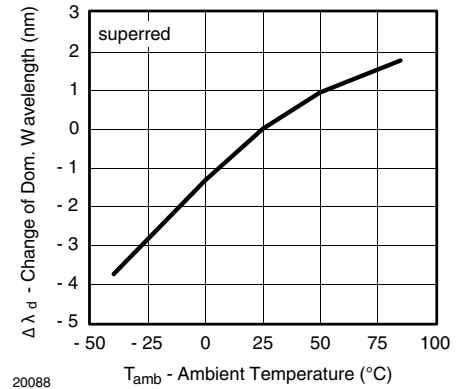

Figure 12. Change of Dominant Wavelength vs. Ambient Temperature

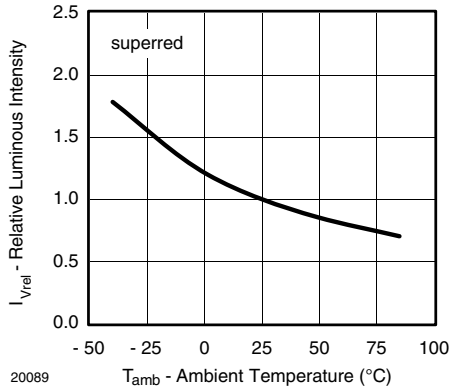

Figure 10. Rel. Luminous Intensity vs. Ambient Temperature

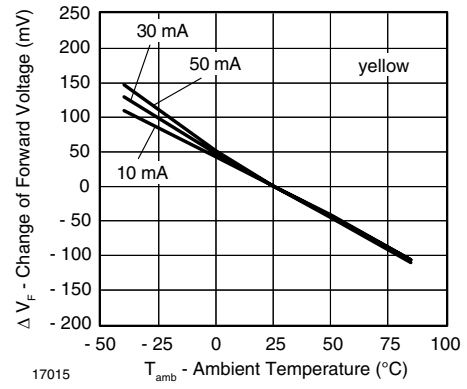

Figure 13. Change of Forward Voltage vs. Ambient Temperature

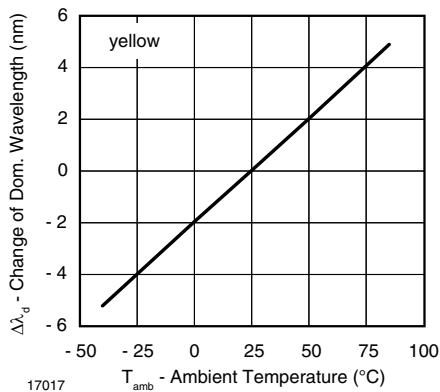

Figure 11. Rel. Luminous Intensity vs. Ambient Temperature

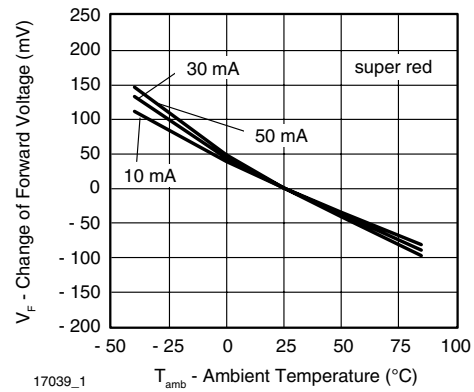
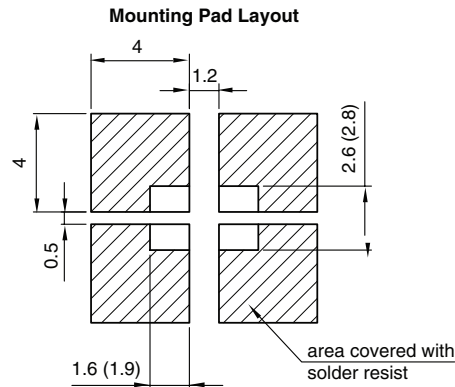
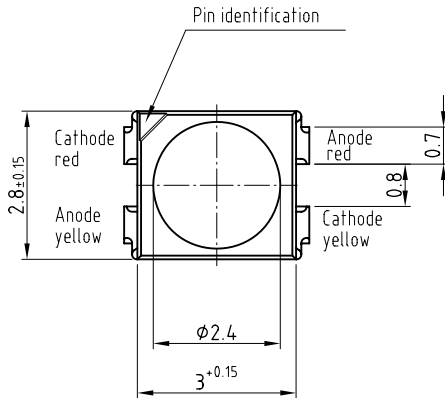
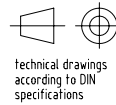
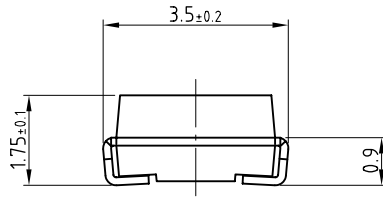

Figure 14. Change of Forward Voltage vs. Ambient Temperature

PACKAGE DIMENSIONS in millimeters



Dimensions: IR and Vaporphase (Wave Soldering)

Drawing-No.: 6.541-5057.01-4
 Issue: 5, 30.05.07
 19899

METHOD OF TAPING/POLARITY AND TAPE AND REEL

SMD LED (VLM.3-SERIES)

Vishay's LEDs in SMD packages are available in an antistatic 8 mm blister tape (in accordance with DIN IEC 40 (CO) 564) for automatic component insertion. The blister tape is a plastic strip with impressed component cavities, covered by a top tape.

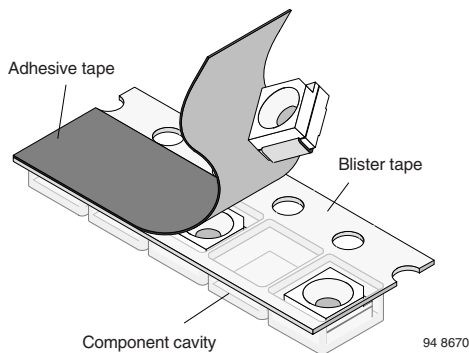

TAPING OF VLM.3...

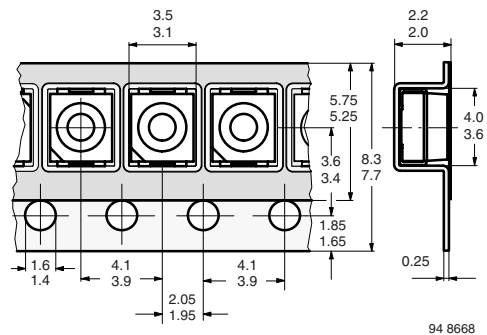

Figure 15. Tape Dimensions in mm for PLCC-2

**REEL PACKAGE DIMENSION IN MILLIMETERS
FOR SMD LEDs, TAPE OPTION GS08
(= 1500 PCS.)**

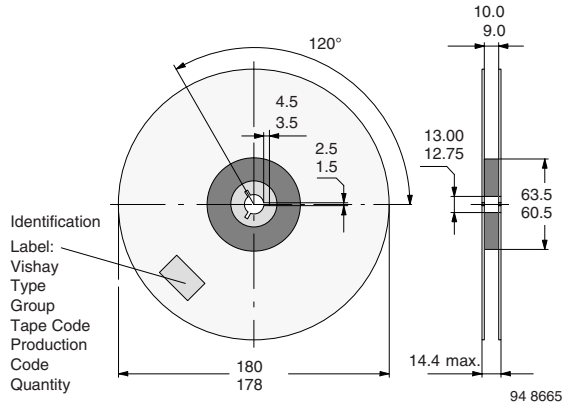

Figure 16. Reel Dimensions - GS08

**REEL PACKAGE DIMENSION IN MILLIMETERS
FOR SMD LEDs, TAPE OPTION GS18
(= 8000 PCS.) PREFERRED**

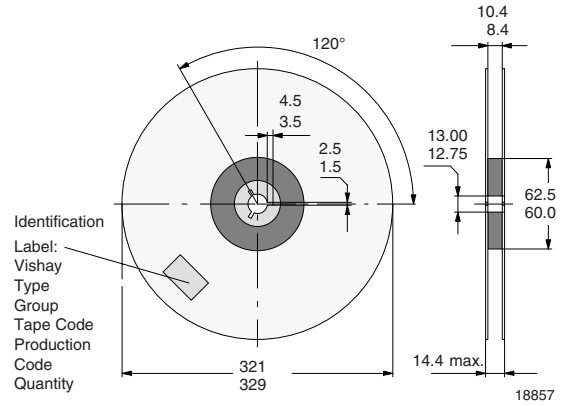

Figure 17. Reel Dimensions - GS18

SOLDERING PROFILE

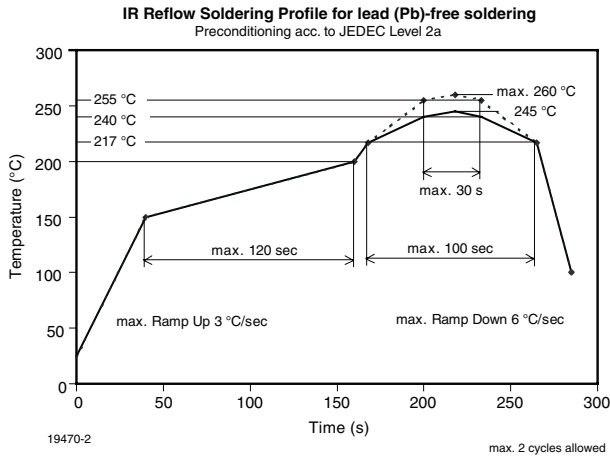

Figure 18. Vishay Lead (Pb)-free Reflow Soldering Profile (acc. to J-STD-020C)

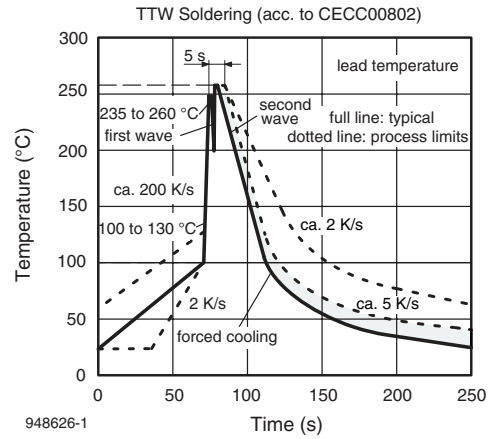
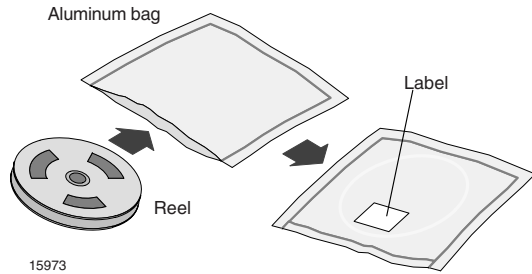

Figure 19. Double Wave Soldering of Opto Devices (all Packages)

DRY PACKING

The reel is packed in an anti-humidity bag to protect the devices from absorbing moisture during transportation and storage.



FINAL PACKING

The sealed reel is packed into a cardboard box. A secondary cardboard box is used for shipping purposes.

RECOMMENDED METHOD OF STORAGE

Dry box storage is recommended as soon as the aluminium bag has been opened to prevent moisture absorption. The following conditions should be observed, if dry boxes are not available:

- Storage temperature 10 °C to 30 °C
- Storage humidity ≤ 60 % RH max.

After more than 672 h under these conditions moisture content will be too high for reflow soldering.

In case of moisture absorption, the devices will recover to the former condition by drying under the following condition:

192 h at 40 °C + 5 °C/- 0 °C and < 5 % RH (dry air/ nitrogen) or

96 h at 60 °C + 5 °C and < 5 % RH for all device containers or

24 h at 100 °C + 5 °C not suitable for reel or tubes.

An EIA JEDEC standard JESD22-A112 level 2a label is included on all dry bags.

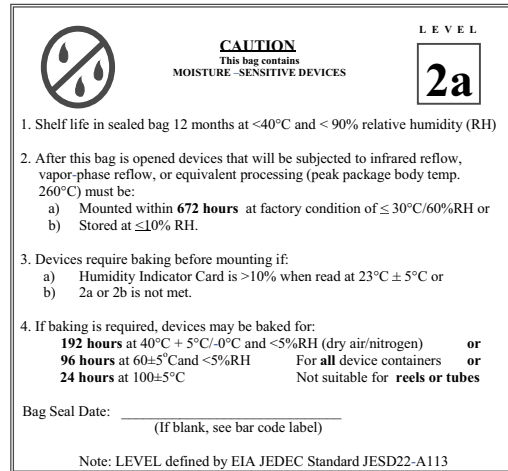

Example of JESD22-A112 level 2a label

ESD PRECAUTION

Proper storage and handling procedures should be followed to prevent ESD damage to the devices especially when they are removed from the antistatic shielding bag. Electro-static sensitive devices warning labels are on the packaging.

VISHAY SEMICONDUCTORS STANDARD BAR CODE LABELS

The Vishay Semiconductors standard bar code labels are printed at final packing areas. The labels are on each packing unit and contain Vishay Semiconductors specific data.

**OZONE DEPLETING SUBSTANCES POLICY STATEMENT**

It is the policy of Vishay Semiconductor GmbH to

1. Meet all present and future national and international statutory requirements.
2. Regularly and continuously improve the performance of our products, processes, distribution and operating systems with respect to their impact on the health and safety of our employees and the public, as well as their impact on the environment.

It is particular concern to control or eliminate releases of those substances into the atmosphere which are known as ozone depleting substances (ODSs).

The Montreal Protocol (1987) and its London Amendments (1990) intend to severely restrict the use of ODSs and forbid their use within the next ten years. Various national and international initiatives are pressing for an earlier ban on these substances.

Vishay Semiconductor GmbH has been able to use its policy of continuous improvements to eliminate the use of ODSs listed in the following documents.

1. Annex A, B and list of transitional substances of the Montreal Protocol and the London Amendments respectively.
2. Class I and II ozone depleting substances in the Clean Air Act Amendments of 1990 by the Environmental Protection Agency (EPA) in the USA.
3. Council Decision 88/540/EEC and 91/690/EEC Annex A, B and C (transitional substances) respectively.

Vishay Semiconductor GmbH can certify that our semiconductors are not manufactured with ozone depleting substances and do not contain such substances.

We reserve the right to make changes to improve technical design
and may do so without further notice.

Parameters can vary in different applications. All operating parameters must be validated for each customer application by the customer. Should the buyer use Vishay Semiconductors products for any unintended or unauthorized application, the buyer shall indemnify Vishay Semiconductors against all claims, costs, damages, and expenses, arising out of, directly or indirectly, any claim of personal damage, injury or death associated with such unintended or unauthorized use.

Vishay Semiconductor GmbH, P.O.B. 3535, D-74025 Heilbronn, Germany



Disclaimer

All product specifications and data are subject to change without notice.

Vishay Intertechnology, Inc., its affiliates, agents, and employees, and all persons acting on its or their behalf (collectively, "Vishay"), disclaim any and all liability for any errors, inaccuracies or incompleteness contained herein or in any other disclosure relating to any product.

Vishay disclaims any and all liability arising out of the use or application of any product described herein or of any information provided herein to the maximum extent permitted by law. The product specifications do not expand or otherwise modify Vishay's terms and conditions of purchase, including but not limited to the warranty expressed therein, which apply to these products.

No license, express or implied, by estoppel or otherwise, to any intellectual property rights is granted by this document or by any conduct of Vishay.

The products shown herein are not designed for use in medical, life-saving, or life-sustaining applications unless otherwise expressly indicated. Customers using or selling Vishay products not expressly indicated for use in such applications do so entirely at their own risk and agree to fully indemnify Vishay for any damages arising or resulting from such use or sale. Please contact authorized Vishay personnel to obtain written terms and conditions regarding products designed for such applications.

Product names and markings noted herein may be trademarks of their respective owners.