

Features

- ✧ For surface mounted application
- ✧ Low profile package
- ✧ Built-in strain relief
- ✧ Glass passivated junction
- ✧ Excellent clamping capability
- ✧ Fast response time: Typically less than 1.0ps from 0 volt to BV min
- ✧ Typical I_R less than 1uA above 10V
- ✧ High temperature soldering guaranteed: 260°C / 10 seconds at terminals
- ✧ Plastic material used carried Underwriters Laboratory Flammability Classification 94V-0
- ✧ 1500 watts peak pulse power capability with a 10/1000 us waveform
- ✧ Green compound with suffix "G" on packing code & prefix "G" on datecode



Mechanical Data

- ✧ Case: Molded plastic
- ✧ Terminals: Pure tin plated, lead free
- ✧ Polarity: Indicated by cathode band
- ✧ Standard packaging: 16mm tape per EIA Std RS-481
- ✧ Weight: 0.26 gram

Ordering Information (example)

Part No.	Package	Packing	Packing code	Packing code (Green)
SMCJ5.0	SMC	850 / 7" REEL	R7	R7G

Maximum Ratings and Electrical Characteristics

Rating at 25 °C ambient temperature unless otherwise specified.

Single phase, half wave, 60 Hz, resistive or inductive load.

For capacitive load, derate current by 20%

Type Number	Symbol	Value	Unit
Peak Power Dissipation at $T_A=25^\circ\text{C}$, $T_p=1\text{ms}$ (Note 1)	P_{PK}	1500	Watts
Steady State Power Dissipation	P_D	5	Watts
Peak Forward Surge Current, 8.3ms Single Half Sine-wave Superimposed on Rated Load (JEDEC method)(Note 2) - Unidirectional Only	I_{FSM}	200	Amps
Maximum Instantaneous Forward Voltage at 50 A for Unidirectional Only (Note 3)	V_F	3.5 / 5.0	Volts
Typical Thermal Resistance	$R_{\theta JC}$	10	°C/W
	$R_{\theta JA}$	55	
Operating and Storage Temperature Range	T_J, T_{STG}	-55 to +150	°C

Note 1: Non-repetitive Current Pulse Per Fig. 3 and Derated above $T_A=25^\circ\text{C}$ Per Fig. 2

Note 2: Mounted on 16mm x 16mm Copper Pads to Each Terminal

Note 3: $V_F=3.5\text{V}$ on SMCJ5.0 thru SMCJ90 Devices and $V_F=5.0\text{V}$ on SMCJ100 thru SMCJ170 Devices

Devices for Bipolar Applications

1. For Bidirectional Use C or CA Suffix for Types SMCJ5.0 through Types SMCJ170
2. Electrical Characteristics Apply in Both Directions

RATINGS AND CHARACTERISTIC CURVES (SMCJ SERIES)

FIG. 1 PEAK PULSE POWER RATING CURVE

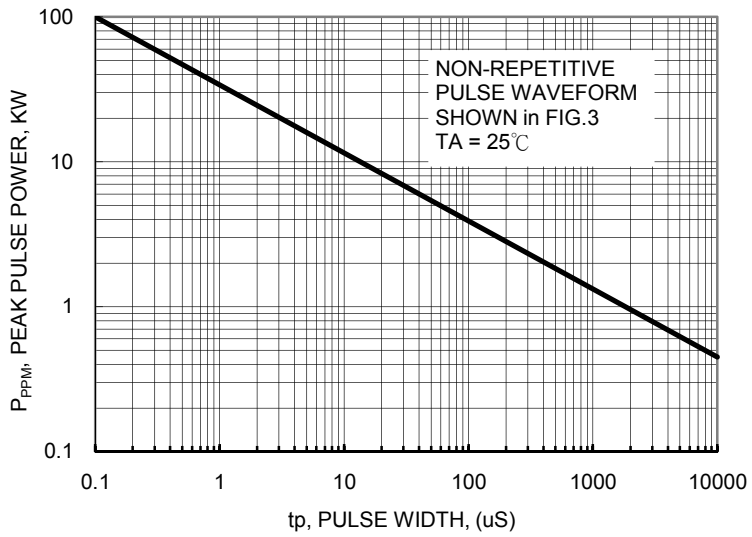

FIG.2 PULSE DERATING CURVE

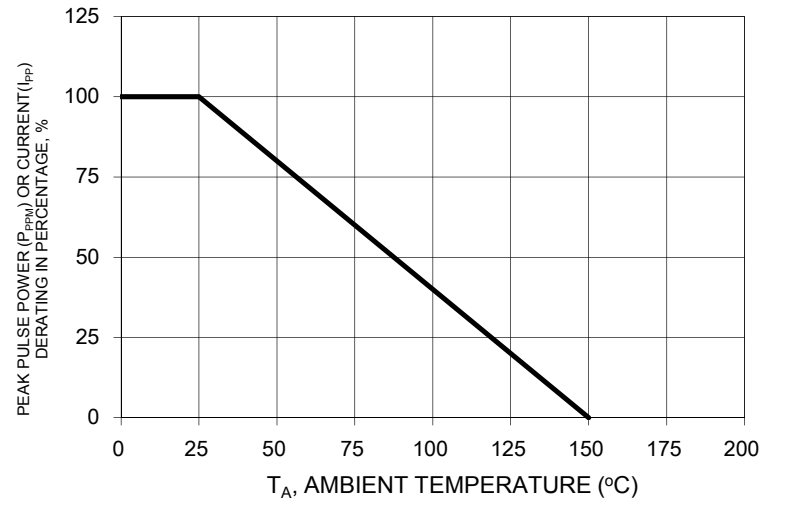

FIG. 3 CLAMPING POWER PULSE WAVEFORM

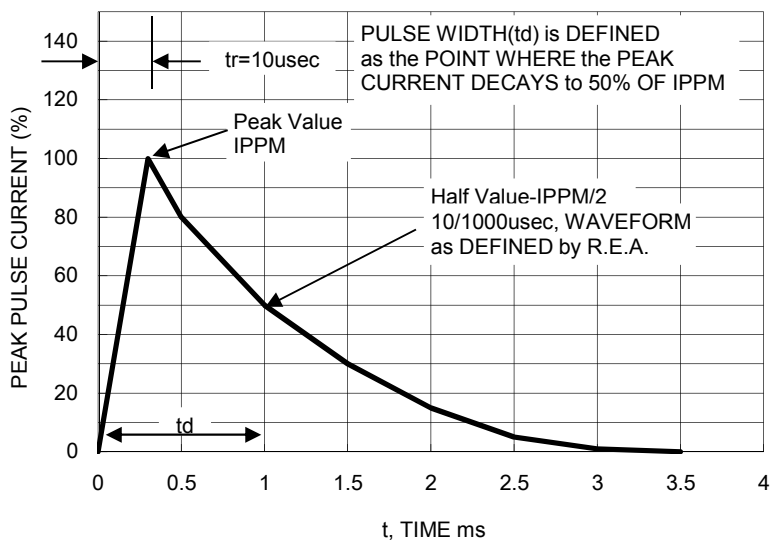

FIG. 4 MAXIMUM NON-REPETITIVE FORWARD SURGE CURRENT

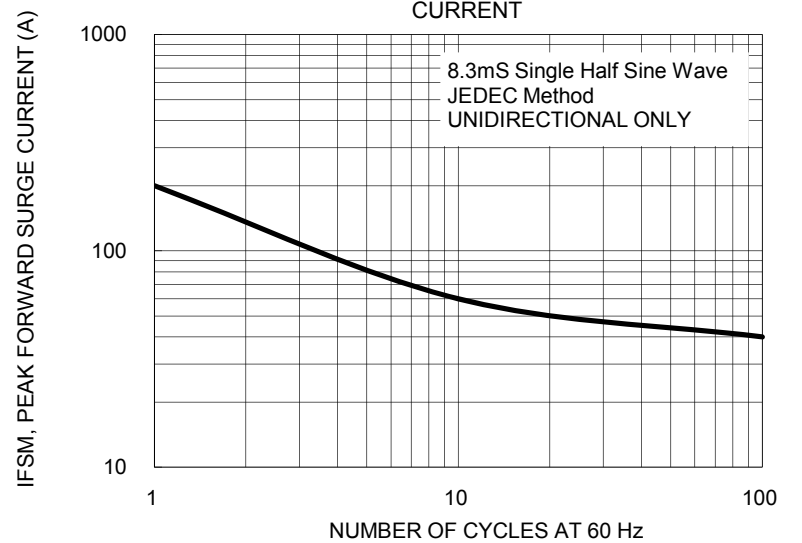
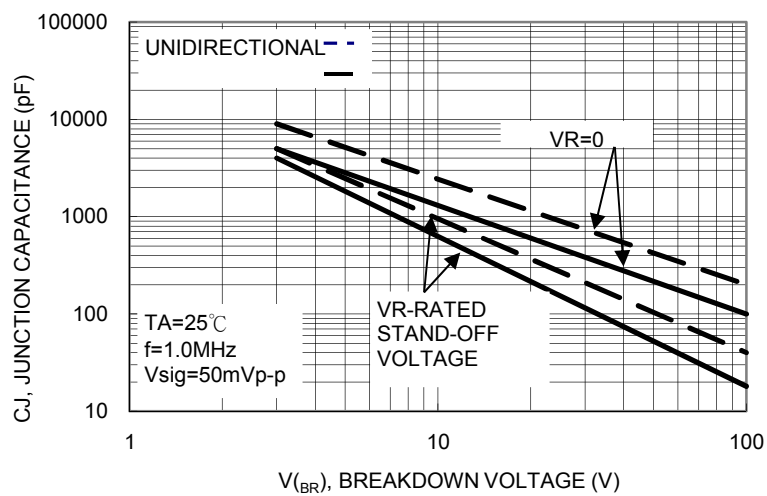

FIG. 5 TYPICAL JUNCTION CAPACITANCE



ELECTRICAL CHARACTERISTICS (TA=25°C unless otherwise noted)

Device	Device Marking Code	Breakdown Voltage VBR (V) at I _T		Test Current I _T (mA)	Stand-Off Voltage V _{WM} (V)	Maximum Reverse Leakage @ V _{WM} I _D (uA)(Note3)	Maximum Peak Surge Current I _{PPM} (A)(Note2)	Maximum Clamping Voltage at IPPM V _c (V)
		Min	Max					
SMCJ5.0	GDD	6.4	7.3	10	5	1000	164	9.6
SMCJ5.0A	GDE	6.4	7	10	5	1000	171	9.2
SMCJ6.0	GDF	6.67	8.15	10	6	1000	138	11.4
SMCJ6.0A	GDG	6.67	7.37	10	6	1000	152	10.3
SMCJ6.5	GDH	7.22	8.82	10	6.5	500	128	12.3
SMCJ6.5A	GDK	7.22	7.98	10	6.5	500	140	11.2
SMCJ7.0	GDL	7.78	9.51	10	7	200	118	13.3
SMCJ7.0A	GDM	7.78	8.6	10	7	200	131	12.0
SMCJ7.5	GDN	8.33	10.30	1	7.5	100	110	14.3
SMCJ7.5A	GDP	8.33	9.21	1	7.5	100	122	12.9
SMCJ8.0	GDQ	8.89	10.9	1	8	50	105	15.0
SMCJ8.0A	GDR	8.89	9.83	1	8	50	115	13.6
SMCJ8.5	GDS	9.44	11.5	1	8.5	20	99	15.9
SMCJ8.5A	GDT	9.44	10.4	1	8.5	20	109	14.4
SMCJ9.0	GDU	10	12.2	1	9	10	93	16.9
SMCJ9.0A	GDV	10	11.1	1	9	10	102	15.4
SMCJ10	GDW	11.1	13.6	1	10	5	83	18.8
SMCJ10A	GDX	11.1	12.3	1	10	5	92	17.0
SMCJ11	GDY	12.2	14.9	1	11	1	78	20.1
SMCJ11A	GDZ	12.2	13.5	1	11	1	86	18.2
SMCJ12	GED	13.3	16.3	1	12	1	71	22.0
SMCJ12A	GEE	13.3	14.7	1	12	1	79	19.9
SMCJ13	GEF	14.4	17.6	1	13	1	66	23.8
SMCJ13A	GEG	14.4	15.9	1	13	1	73	21.5
SMCJ14	GEH	15.6	19.1	1	14	1	61	25.8
SMCJ14A	GEK	15.6	17.2	1	14	1	67	23.2
SMCJ15	GEL	16.7	20.4	1	15	1	58	26.9
SMCJ15A	GEM	16.7	18.5	1	15	1	64	24.4
SMCJ16	GEN	17.8	21.8	1	16	1	54	28.8
SMCJ16A	GEP	17.8	19.7	1	16	1	60	26.0
SMCJ17	GEQ	18.9	23.1	1	17	1	51	30.5
SMCJ17A	GER	18.9	20.9	1	17	1	57	27.6
SMCJ18	GES	20	24.4	1	18	1	48	32.2
SMCJ18A	GET	20	22.1	1	18	1	53	29.2
SMCJ20	GEU	22.2	27.1	1	20	1	43	35.8
SMCJ20A	GEV	22.2	24.5	1	20	1	48	32.4
SMCJ22	GEW	24.4	29.8	1	22	1	39	39.4
SMCJ22A	GEX	24.4	26.9	1	22	1	44	35.5
SMCJ24	GEY	26.7	32.6	1	24	1	36	43.0
SMCJ24A	GEZ	26.7	29.5	1	24	1	40	38.9
SMCJ26	GFD	28.9	35.3	1	26	1	33	46.6
SMCJ26A	GFE	28.9	31.9	1	26	1	37	42.1
SMCJ28	GFF	31.1	38	1	28	1	31	50.0
SMCJ28A	GFG	31.1	34.4	1	28	1	34	45.4
SMCJ30	GFH	33.3	40.7	1	30	1	29	53.5
SMCJ30A	GFK	33.3	36.8	1	30	1	32	48.4
SMCJ33	GFL	36.7	44.9	1	33	1	26	59.0
SMCJ33A	GFM	36.7	40.6	1	33	1	29	53.3
SMCJ36	GFN	40	48.9	1	36	1	24	64.3
SMCJ36A	GFP	40	44.2	1	36	1	27	58.1

ELECTRICAL CHARACTERISTICS (TA=25°C unless otherwise noted)

Device	Device Marking Code	Breakdown Voltage VBR (V) at I _T		Test Current I _T (mA)	Stand-Off Voltage V _{WM} (V)	Maximum Reverse Leakage @ V _{WM} I _D (uA)	Maximum Peak Pulse Surge Current I _{PPM} (A)(Note5)	Maximum Clamping Voltage at IPPM V _c (V) (Note5)
		Min	Max					
SMCJ40	GFQ	44.4	54.3	1	40	1	22	71.4
SMCJ40A	GFR	44.4	49.1	1	40	1	24	64.5
SMCJ43	GFS	47.8	58.4	1	43	1	20	76.7
SMCJ43A	GFT	47.8	52.8	1	43	1	22	69.4
SMCJ45	GFU	50	61.1	1	45	1	19	80.3
SMCJ45A	GFV	50	55.3	1	45	1	21	72.7
SMCJ48	GFW	53.3	65.1	1	48	1	18	85.5
SMCJ48A	GFX	53.3	58.9	1	48	1	20	77.4
SMCJ51	GFY	56.7	69.3	1	51	1	17	91.1
SMCJ51A	GFZ	56.7	62.7	1	51	1	19	82.4
SMCJ54	GGD	60	73.3	1	54	1	16	96.3
SMCJ54A	GGE	60	66.3	1	54	1	18	87.1
SMCJ58	GGF	64.4	78.7	1	58	1	15	103
SMCJ58A	GGG	64.4	71.2	1	58	1	16	93.6
SMCJ60	GGH	66.7	81.5	1	60	1	14	107
SMCJ60A	GGK	66.7	73.7	1	60	1	16	96.8
SMCJ64	GGL	71.1	86.9	1	64	1	13.8	114
SMCJ64A	GGM	71.1	78.6	1	64	1	15	103
SMCJ70	GGN	77.8	95.1	1	70	1	12.6	125
SMCJ70A	GGP	77.8	86	1	70	1	13.9	113
SMCJ75	GGQ	83.3	102	1	75	1	11.7	134
SMCJ75A	GGR	83.3	92.1	1	75	1	13	121
SMCJ78	GGS	86.7	106	1	78	1	11.3	139
SMCJ78A	GGT	86.7	95.8	1	78	1	12.5	126
SMCJ85	GGU	94.4	115	1	85	1	10.4	151
SMCJ85A	GGV	94.4	104	1	85	1	11.5	137
SMCJ90	GGW	100	122	1	90	1	9.8	160
SMCJ90A	GGX	100	111	1	90	1	10.7	146
SMCJ100	GGY	111	136	1	100	1	8.8	179
SMCJ100A	GGZ	111	123	1	100	1	9.7	162
SMCJ110	GHD	122	149	1	110	1	8	196
SMCJ110A	GHE	122	135	1	110	1	8.9	177
SMCJ120	GHF	133	163	1	120	1	7.3	214
SMCJ120A	GHG	133	147	1	120	1	8.1	193
SMCJ130	GHH	144	176	1	130	1	6.8	231
SMCJ130A	GHK	144	159	1	130	1	7.5	209
SMCJ150	GHL	167	204	1	150	1	5.8	266
SMCJ150A	GHM	167	185	1	150	1	6.4	243
SMCJ160	GHN	178	218	1	160	1	5.4	287
SMCJ160A	GHP	178	197	1	160	1	6	259
SMCJ170	GHQ	189	231	1	170	1	5.1	304
SMCJ170A	GHR	189	209	1	170	1	5.7	275

Notes:

1. V_{BR} measure after I_T applied for 300us, I_T=square wave pulse or equivalent.
2. Surge current waveform per Figure. 3 and derate per Figure. 2.
3. For bipolar types having V_{WM} of 10 volts and less, the I_D limit is doubled.
4. All terms and symbols are consistent with ANSI/IEEE C62.35.

Ordering information

Part No.	Package	Packing	Packing code	Green Compound Packing code
SMCJxx (Note)	SMC	850 / 7" REEL	R7	R7G
	SMC	3K / 13" REEL	R6	R6G
	SMC	3K / 13" Plstic REEL	M6	M6G

Note: "x" is Device Code from "5.0" thru "170".

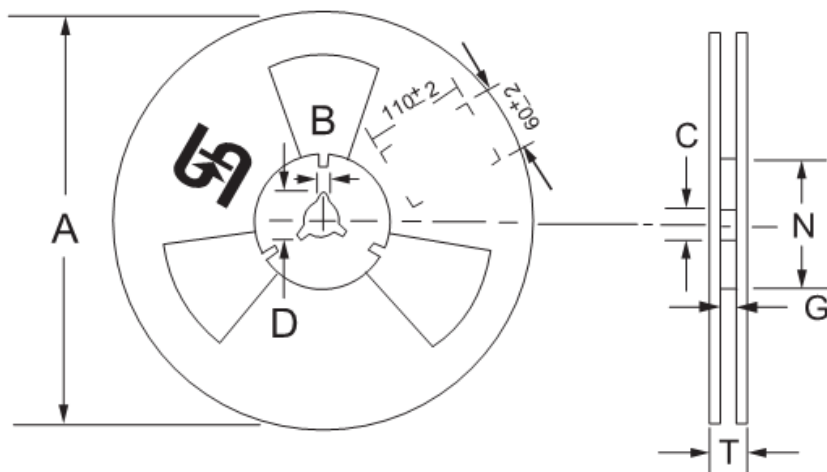
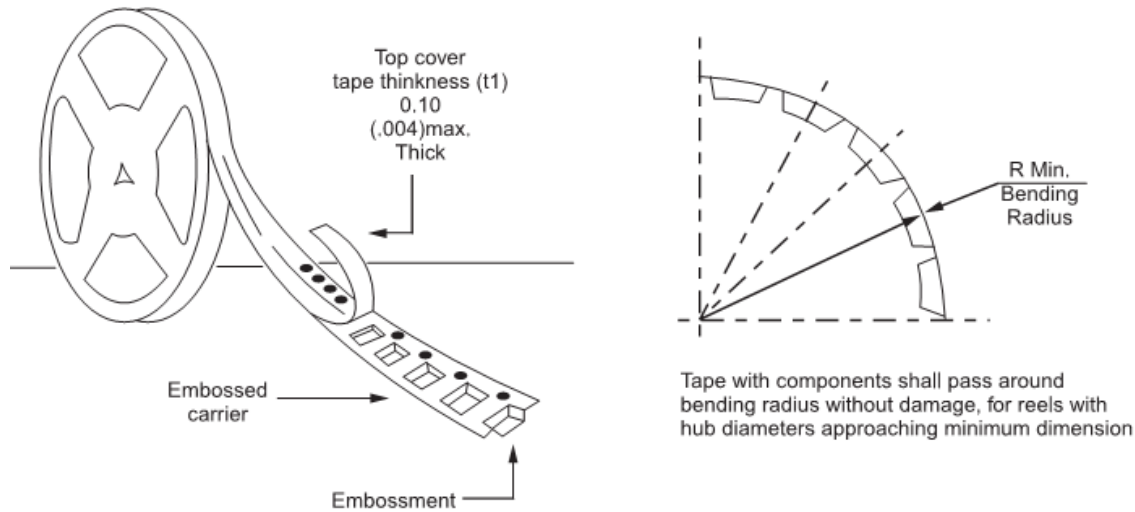
Tape & Reel specification

Reel Size	Tape Size	A	B	C	D	N	G	T
		± 2.0	± 0.4	$+0.5; -0.2$	min	± 1.0	$+0.8; -0$	max
7"	16mm	178	1.9	13	21	62	16.2	18.6
Reel Size	Tape Size	A	B	C	D	N	G	T
		max	± 0.5	± 0.5	min	± 0.5	$+2.0; -0$	max
13"	16mm	330	2	13	20.2	75	16.4	22.4

Unit (mm)

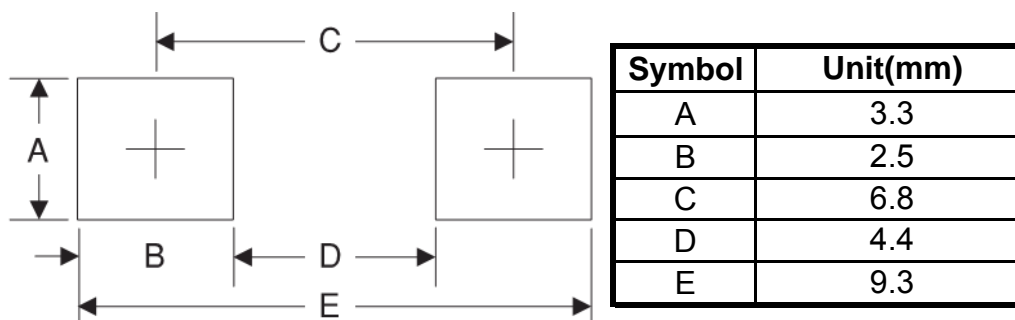
Suggested PAD Layout

Dimensions

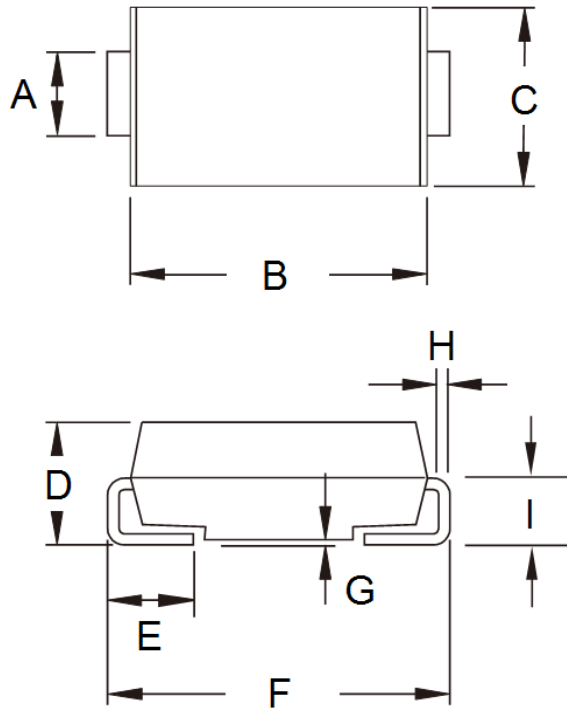

DIM.	Unit(mm)		Unit(inch)	
	Min	Max	Min	Max
A	2.90	3.20	0.114	0.126
B	6.60	7.11	0.260	0.280
C	5.59	6.22	0.220	0.245
D	2.00	2.62	0.079	0.103
E	1.00	1.60	0.039	0.063
F	7.75	8.13	0.305	0.320
G	0.10	0.20	0.004	0.008
H	0.15	0.31	0.006	0.012
I	1.26	1.56	0.050	0.061

Marking Diagram

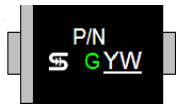

P/N = Specific Device Code
G = Green Compound
YW = Date Code

TVS APPLICATION NOTES:

Transient Voltage Suppressors may be used at various points in a circuit to provide various degrees of protection. The following is a typical linear power supply with transient voltage suppressor units played at different points. All provide protection

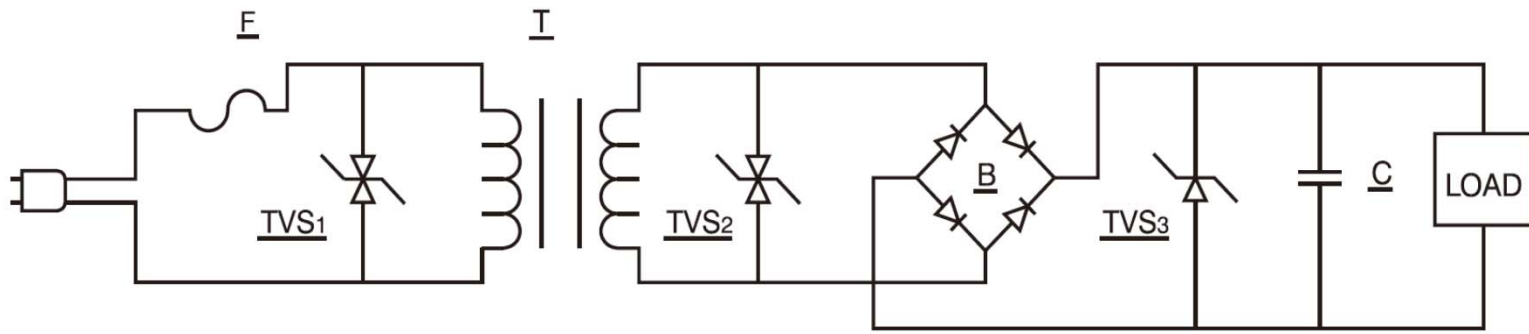

FIGURE 1

Transient Voltage Suppressor 1 provides maximum protection. However, the system will probably require replacement of the line fuse(F) since it provides a dominant portion of the series impedance when a surge is encountered.

Howver, we do not recommend to use the TVS diode here, unless we can know the electric circuit impedance and the magnitude of surge rushed into the circuit. Otherwise the TVS diode is easy to be destroyed by voltage surge.

Transient Voltage Suppressor 2 provides execllent protection of circuitry excluding the transformer(T). However, since the transformer is a large part of the series impedance, the chance of the line fuse opening during the surge condition is reduced.

Transient Voltage Suppressor 3 provides the load with complete protection. It uses a unidirectional Transient Voltage Suppressor, which is a cost advantage. The series impedance now includes the line fuse, transformer, and bridge rectifier(B) so failure

Any combination of this three, or any one of these applivations, will prevent damage to the load. This would require varying trade-offs in power supply protection versus maintenance(changing the time fuse).

An additional method is to utilize the Trans

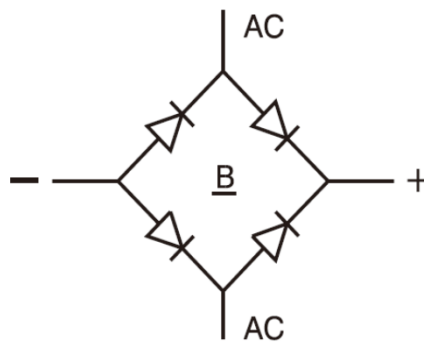

FIGURE 2