

DC-6GHz DPDT Diversity Switch

Features:

- ◆ Low Insertion loss
- ◆ Low Harmonic Distortion
- ◆ High Transmit-Receive Isolation
- ◆ Suitable for WLAN 802.11a and 802.11b/g Applications
- ◆ Filtronic Advanced GaAs pHEMT Technology

Functional Schematic

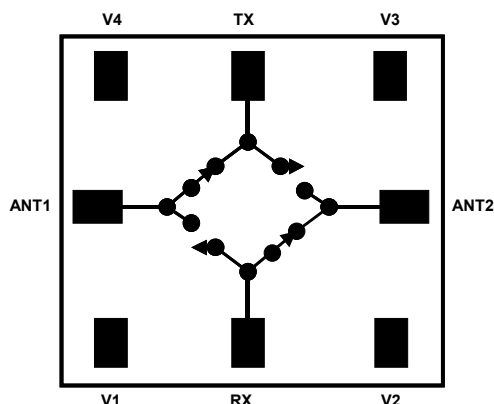

Description and Applications:

The FMS2007 is a low loss linear Double-Pole Double-Throw dual band diversity switch designed for use in WLAN applications. Typical applications are for UNII, Hiperlan, 802.11a and 802.11b/g systems that employ two antennas for transmit and receive diversity.

Electrical Specifications: ($T_{\text{AMBIENT}} = 25^{\circ}\text{C}$, $V_{\text{control}} = 0\text{V}/2.5\text{V}$, $Z_{\text{IN}} = Z_{\text{OUT}} = 50\Omega$)

Parameter	Test Conditions	Min	Typ	Max	Units
Insertion Loss	2.4GHz		0.9	1.1	dB
Insertion Loss	6GHz		1.3	1.5	dB
Return Loss	2.4GHz		16		dB
Return Loss	6GHz		12		dB
Tx-Rx Isolation	2.4GHz	27	39		dB
Tx-Rx Isolation	6GHz	27	28		dB
2nd Harmonic Level	2.4, 6 GHz, Pin = 20dBm, Vctrl = 2.4V		-70		dBc
3rd Harmonic Level	2.4, 6 GHz, Pin = 20dBm, Vctrl = 2.4V		-70		dBc
Switching speed	Vctrl=2.4V, Pin=20dBm 10% to 90% RF and 90% to 10% RF		30		ns

Note: External DC blocking capacitors are required on all RF ports (typ: 47pF).
All unused ports terminated in 50Ω.

Absolute Maximum Ratings:

Parameter	Absolute Maximum
Max Input Power	+27dBm
Control Voltage	+5V
Operating Temperature	-40°C to +100°C
Storage Temperature	-55°C to +150°C

Note: Exceeding any one of these absolute maximum ratings may cause permanent damage to the device.

Truth Table:

State	V1	V2	V3	V4	PATH(S)
1	HIGH	LOW	LOW	LOW	RX-ANT1
2	LOW	HIGH	LOW	LOW	RX-ANT2
3	LOW	LOW	HIGH	LOW	TX-ANT2
4	LOW	LOW	LOW	HIGH	TX-ANT1
5	LOW	HIGH	LOW	HIGH	TX-ANT1 & RX-ANT2
6	HIGH	LOW	HIGH	LOW	TX-ANT2 & RX-ANT1

Note:

'High' = +2.4V to +5V
 'Low' = 0V to +0.2V

Pad and Die Layout:

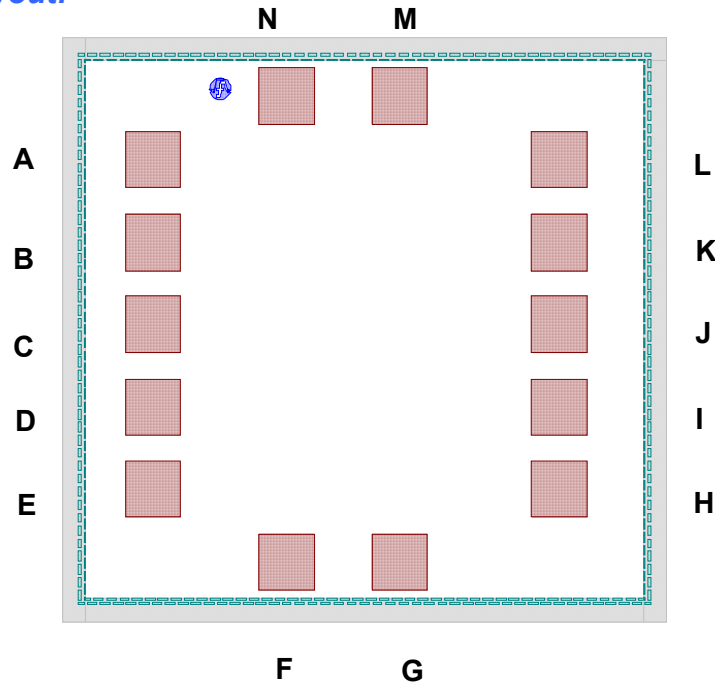

Pad Number	Pad Name	Description	Pin Coordinates (x μm , y μm)
A	GND	Ground	(142.1 , 709.0)
B	ANT1	Antenna 1	(142.1 , 581.6)
C	GND	Ground	(142.1 , 448.5)
D	ANT2	Antenna 2	(142.1 , 327.9)
E	GND	Ground	(142.1 , 201.4)
F	V1	RX-Ant1	(349.8 , 88.5)
G	V3	TX-Ant2	(522.2 , 88.5)
H	GND	Ground	(769.2 , 201.4)
I	RX	Receive	(769.2 , 327.9)
J	GND	Ground	(769.2 , 448.5)
K	TX	Transmit	(769.2 , 581.6)
L	GND	Ground	(769.2 , 709.0)
M	V2	RX-Ant2	(522.2 , 807.7)
N	V4	Tx-Ant1	(349.8 , 807.7)

Note: Co-ordinates are referenced from the bottom left hand corner of the die to the centre of the bond pad opening

Die Size (μm)	Die Thickness (μm)	Min. Bond Pad Pitch(μm)	Min. Bond pad opening (μm)
897x929	150	127	80x80

Typical Performance Curves:

On Wafer Measurements:

Insertion Loss

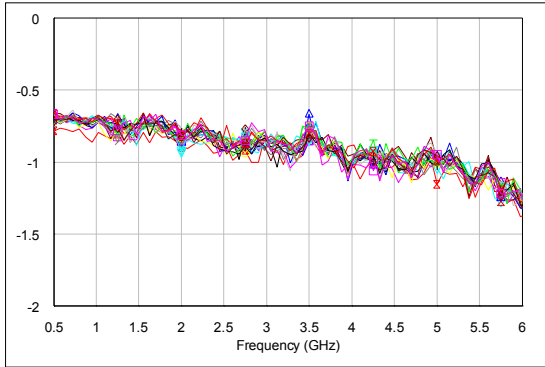

A1-TX Isolation

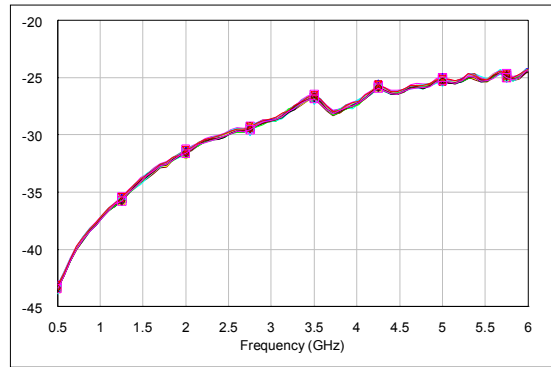

Evaluation Board:

Insertion Loss

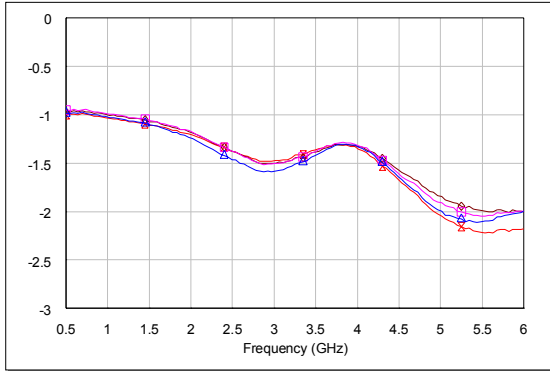

Return Loss

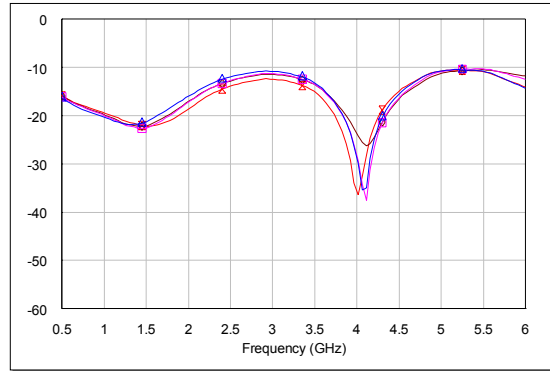

Note: Evaluation Board Insertion Loss to be corrected

A1-TX, A2-RX Isolation

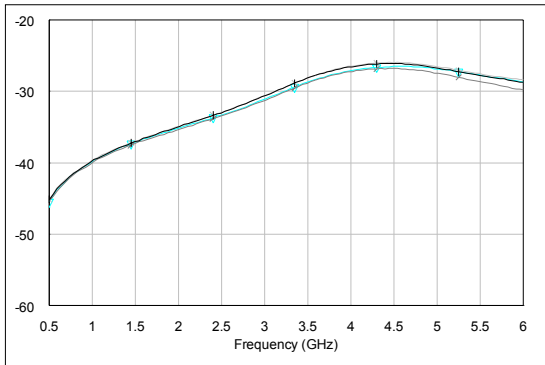

RX-TX Isolation

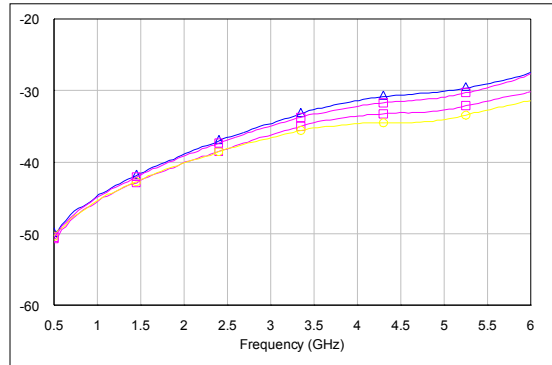

Evaluation Board Data:

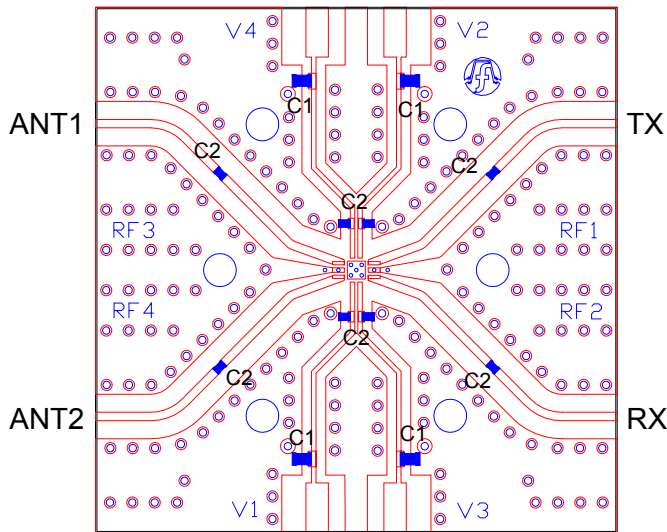

BOM

Label	Component
C1	Capacitor, 100pF, 0603
C2	Capacitor, 47pF, 0402

Evaluation Board Correction Data

Frequency	Insertion Loss
2.4GHz	0.25dB
6.0GHz	0.80dB

Ordering Information:

Part Number	Description
FMS2007-000-WP	Die – waffle pak
FMS2007-000-GP	Die – gel pak
FMS2007-000-EB	Die mounted on evaluation board
FMS2007-000-FF	Wafer mounted on film frame

Preferred Assembly Instructions:

GaAs devices are fragile and should be handled with great care. Specially designed collets should be used where possible.

The back of the die is not metallised and the recommended mounting method is by the use of conductive epoxy. Epoxy should be applied to the attachment surface uniformly and sparingly to avoid encroachment of epoxy on to the top face of the die and ideally should not exceed half the chip height. For automated dispense Ablestick LMISR4 is recommended and for manual dispense Ablestick 84-1 LMI or 84-1 LMIT are recommended. These should be cured at a temperature of 150°C for 1 hour in an oven especially set aside for epoxy curing only. If possible the curing oven should be flushed with dry nitrogen.

This part has gold (Au) bond pads requiring the use of gold (99.99% pure) bondwire. It is recommended that 25.4µm diameter gold wire is used. Thermosonic ball bonding is preferred. A nominal stage temperature of 150°C and a bonding force of 40g has been shown to give effective results for 25µm wire. Ultrasonic energy shall be kept to a minimum. For this bonding technique, stage temperature should not be raised above 200°C and bond force should not be raised above 60g. Thermosonic wedge bonding and thermocompression wedge bonding can also be used to achieve good wire bonds.

Bonds should be made from the die first and then to the mounting substrate or package. The physical length of the bondwires should be minimised especially when making RF or ground connections.

Handling Precautions:

To avoid damage to the devices care should be exercised during handling. Proper Electrostatic Discharge (ESD) precautions should be observed at all stages of storage, handling, assembly, and testing. These devices should be treated as Class 1A (0-500 V) as defined in JEDEC Standard No. 22-A114-B. Further information on ESD control measures can be found in MIL-STD-1686 and MIL-HDBK-263.

Disclaimers:

This product is not designed for use in any space based or life sustaining/supporting equipment.