

WISE-3320

100-Node Wireless IoT Network Controller

Preliminary



Features

- All-in-One RISC-based Intelligent and Industrial platform with TI Sitara AM3352 Dual CORTEX-A8 1.0GHz processor
- Linux 3.2.0 BSP embedded
- Compliant to 6LoWPAN and IEEE 802.15.4e standards
- AES-128 bit encryption
- Supports up to 100 WPAN nodes
- Power saving mode and fanless design
- SUSIAccess for IoT management software

Introduction

Advantech RISC-based WPAN Network Controller, WISE-3320, is powered by the TI Sitara AM3352 Dual CORTEX-A8 1.0GHz processor, Linux 3.2.0 BSP and Linear Dust LTC5800 Cortex M3 MCU. With changeable embedded modules and feature-rich protocol, WISE-3320 creates a cost-effective open platform for easy integration and development in different M2M/IoT applications. Connect with Advantech WPAN sensor nodes, by Smartmesh IP protocol for applications in wireless sensor networks where seamless internet protocol (IP) is valued. Also, SUSIAccess for IoT allows users to remote manage their devices and the entire wireless sensor network.

Specifications

Processor System	CPU	TI Sitara AM3352 Dual CORTEX-A8 1.0GHz
	DRAM	On-board DDR3 1 GB
	Flash	4 MB SPI NOR Flash and 4 GB eMMC
I/O Interface	COM	1 RS232 (CTS, RTS, Tx, Rx)
	LAN	2 10/100/1000 Mbps (PSE 1 & PD*1)
	Antenna	2 SMA Antenna ports
	Power Reset	1
	Power on/off	1 Power on/off switch
	LED	2 WSN connection status
Power	DC-input	DC 9~30V Phoenix connector
WSN	Standards-based	Based on 6LoWPAN and IEEE 802.15.4e standards
	Frequency Band	2.4000 ~ 2.4835 GHz
	Number of Channels	15
	Channel Separation	5 MHz
	Raw Data Rate	250 Kbps
	Output Power	0 ~ 8 dBm
Software Support	OS	Linux V3.2.0
	Software Development Package	.Net, C/C++, Java, VB
Mechanical & Environmental	Dimensions	205 x 127 x 31 mm (LxWxH) with a metal plate 180 x 114 x 31 mm without a metal plate
	Weight	312g
	Operating Temperature	-20 ~ 70° C
	Operating Humidity	5% ~ 95% Relative Humidity, non-condensing
	Mounting	Metal bracket wall mount

Dimensions

Unit: mm (inch)

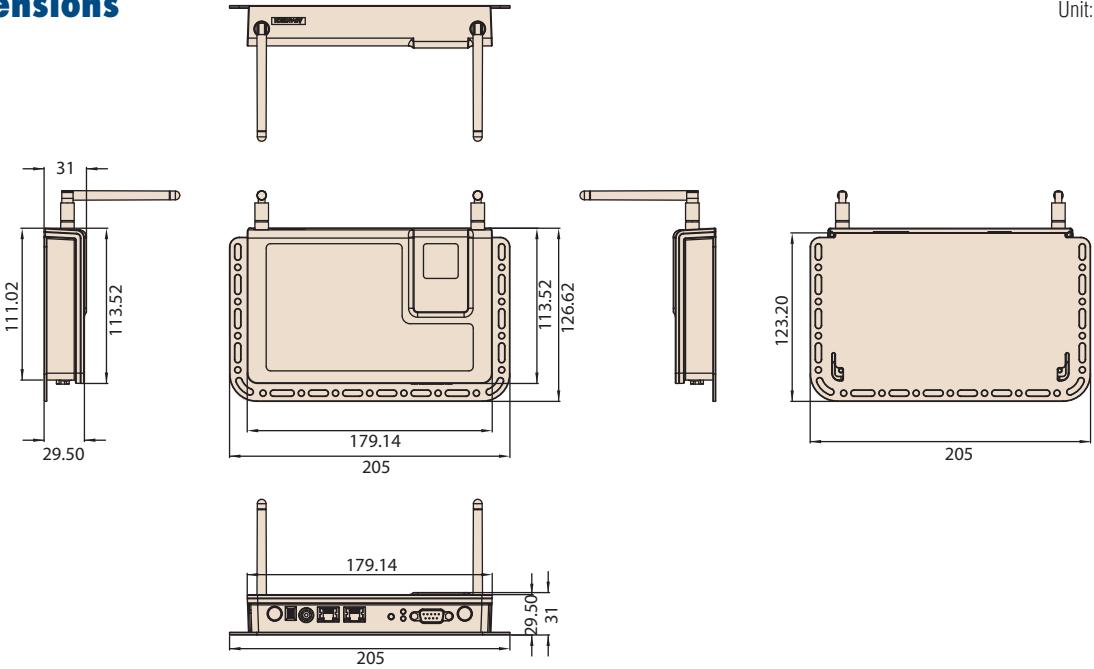

Plus Package Benefits

Free-bundled Demo Software



Remote Device Management Software



System Recovery



Data Security



Remote Management



Plug-n-Play Installation

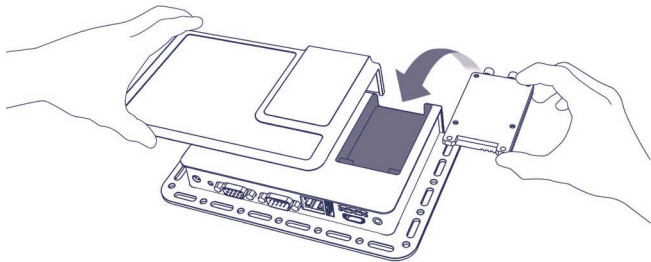

Ordering Information

Model Name	Description
WISE-3320	100-node Wireless IoT Network Gateway Controller by TI Sitara AM3352 Dual CORTEX-A8 1.0 GHz Processor