



CY8C20X36A/46A/66A/96A/46AS/66AS

1.8 V CapSense[®] Controller with SmartSense[™] Auto-tuning

Features

- Wide operating range: 1.71 V to 5.5 V
- Ultra low deep sleep current: 100 nA
 - Configurable capacitive sensing elements
 - 7 μ A per sensor at 500 ms scan rate
 - Supports SmartSense Auto-tuning
 - Supports a combination of CapSense buttons, sliders, touchpads, touchscreens, and proximity sensors
 - SmartSense_EMC offers superior noise immunity for applications with challenging conducted and radiated noise conditions
- Powerful Harvard-architecture processor
 - M8C CPU – Up to 4 MIPS with 24 MHz Internal clock, external crystal resonator or clock signal
 - Low power at high speed
- Temperature range: -40°C to $+85^{\circ}\text{C}$
- Flexible on-chip memory
 - Three program/data storage size options:
 - 8 KB flash/1 KB SRAM
 - 16 KB flash/2 KB SRAM
 - 32 KB flash/2 KB SRAM
 - 50,000 flash erase/write cycles
 - Partial flash updates
 - Flexible protection modes
 - In-system serial programming (ISSP)
- Full-speed USB
 - 12 Mbps USB 2.0 compliant
- Precision, programmable clocking
 - Internal main oscillator (IMO): 6/12/24 MHz \pm 5%
 - Internal low speed oscillator (ILO) at 32 kHz for watchdog and sleep timers
 - Precision 32 kHz oscillator for optional external crystal
- Programmable pin configurations
 - Up to 36 general-purpose I/Os (GPIOs) (depending on package)
 - Dual mode GPIO: All GPIOs support digital I/O and analog inputs
 - 25-mA sink current on each GPIO
 - 120 mA total sink current on all GPIOs
 - Pull-up, high Z, open-drain modes on all GPIOs
 - CMOS drive mode -5 mA source current on ports 0 and 1 and 1 mA on ports 2, 3, and 4
 - 20 mA total source current on all GPIOs
- Versatile analog system
 - Low-dropout voltage regulator for all analog resources
 - Common internal analog bus enabling capacitive sensing on all pins
 - High power supply rejection ratio (PSRR) comparator
 - 8 to 10-bit incremental analog-to-digital converter (ADC)
- Additional system resources
 - I²C slave:
 - Selectable to 50 kHz, 100 kHz, or 400 kHz
 - SPI master and slave: Configurable 46.9 kHz to 12 MHz
 - Three 16-bit timers
 - Watchdog and sleep timers
 - Integrated supervisory circuit
 - Emulated E2PROM using flash memory
- Complete development tools
 - Free development tool (PSoC Designer[™])
 - Full-featured, in-circuit emulator (ICE) and programmer
 - Full-speed emulation
 - Complex breakpoint structure
 - 128 KB trace memory
- Versatile package options
 - 16-pin 3 \times 3 \times 0.6 mm QFN
 - 24-pin 4 \times 4 \times 0.6 mm QFN
 - 32-pin 5 \times 5 \times 0.6 mm QFN
 - 48-pin SSOP
 - 48-pin 7 \times 7 \times 1.0 mm QFN
 - 30-ball WLCSP^[1]

Note

1. Contact your local sales office for details.

Logic Block Diagram

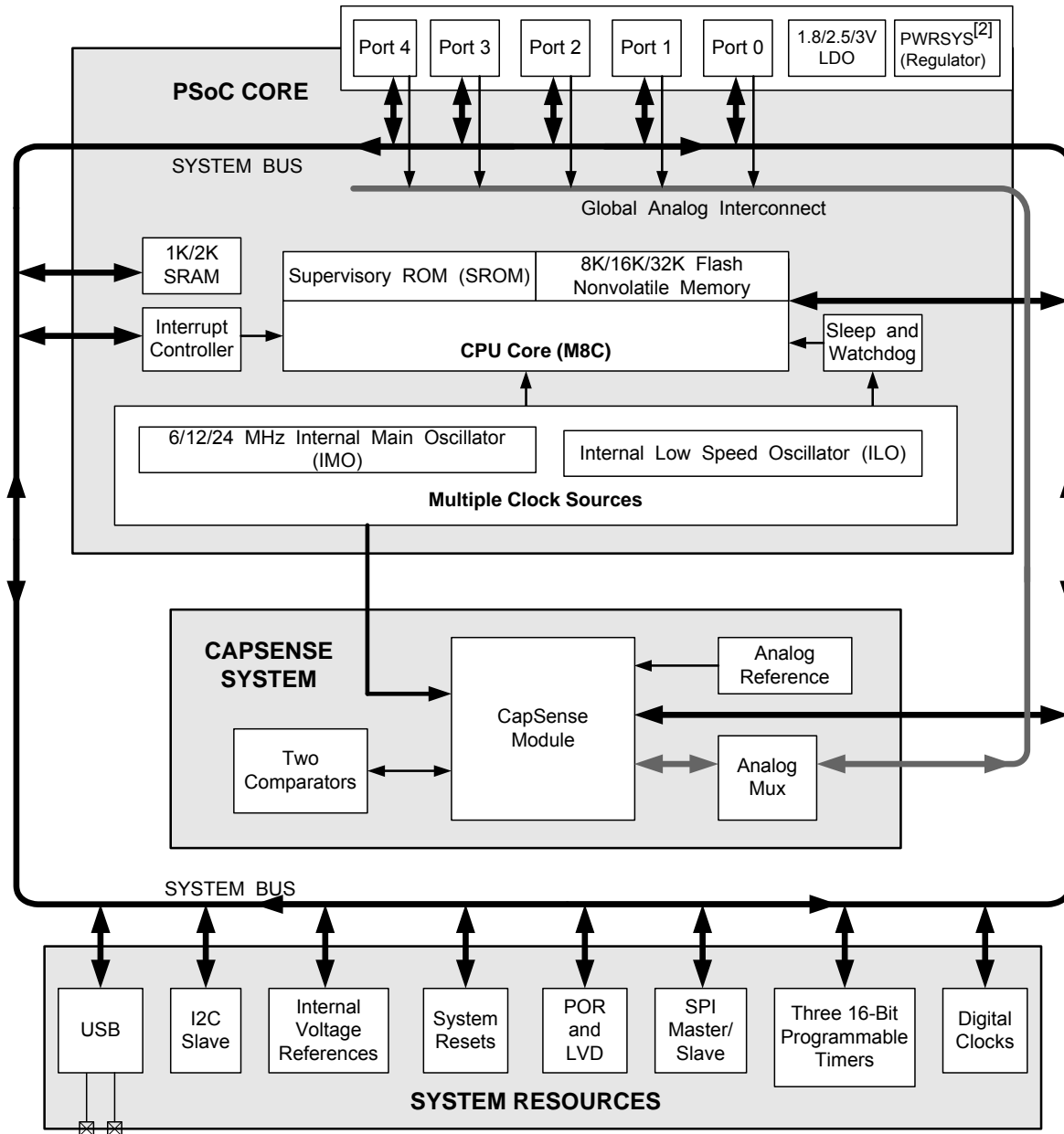

Note
2. Internal voltage regulator for internal circuitry

Contents

PSoC® Functional Overview	4	ADC Electrical Specifications	24
PSoC Core	4	DC POR and LVD Specifications	25
CapSense System.....	4	DC Programming Specifications	25
Additional System Resources	5	DC I2C Specifications	26
Getting Started	6	DC Reference Buffer Specifications.....	26
CapSense Design Guides	6	DC IDAC Specifications	26
Silicon Errata	6	AC Chip-Level Specifications	27
Development Kits	6	AC GPIO Specifications	28
Training	6	AC Comparator Specifications	29
CYPros Consultants	6	AC External Clock Specifications.....	29
Solutions Library.....	6	AC Programming Specifications.....	30
Technical Support	6	AC I2C Specifications.....	31
Development Tools	7	Packaging Information	34
PSoC Designer Software Subsystems	7	Thermal Impedances.....	37
Designing with PSoC Designer	8	Capacitance on Crystal Pins	37
Select User Modules	8	Solder Reflow Specifications.....	37
Configure User Modules.....	8	Development Tool Selection	38
Organize and Connect	8	Software	38
Generate, Verify, and Debug.....	8	Development Kits	38
Pinouts	9	Evaluation Tools.....	38
16-pin QFN (12 Sensing Inputs)[4]	9	Device Programmers.....	38
24-pin QFN (12 Sensing Inputs).....	10	Accessories (Emulation and Programming).....	39
24-pin QFN - 18 Sensing Inputs (With USB).....	11	Third Party Tools	39
30-ball WLCSP (26 Sensing Inputs).....	12	Build a PSoC Emulator into Your Board.....	39
32-pin QFN (27 Sensing Inputs).....	13	Ordering Information	40
32-pin QFN - 24 Sensing Inputs (With USB).....	14	Ordering Code Definitions	42
48-pin SSOP (33 Sensing Inputs)	15	Acronyms	43
48-pin QFN (35 Sensing Inputs).....	16	Reference Documents	43
48-pin QFN - 35 Sensing Inputs (With USB).....	17	Document Conventions	43
48-pin QFN (OCD)	18	Units of Measure	43
Electrical Specifications	19	Numeric Naming.....	44
Absolute Maximum Ratings.....	19	Glossary	44
Operating Temperature	19	Document History Page	45
DC Chip-Level Specifications	20	Sales, Solutions, and Legal Information	47
DC GPIO Specifications	21	Worldwide Sales and Design Support.....	47
DC Analog Mux Bus Specifications.....	23	Products	47
DC Low Power Comparator Specifications	23	PSoC Solutions	47
Comparator User Module Electrical Specifications ...	24		

PSoC[®] Functional Overview

The PSoC family consists of on-chip controller devices, which are designed to replace multiple traditional microcontroller unit (MCU)-based components with one, low cost single-chip programmable component. A PSoC device includes configurable analog and digital blocks, and programmable interconnect. This architecture allows the user to create customized peripheral configurations, to match the requirements of each individual application. Additionally, a fast CPU, Flash program memory, SRAM data memory, and configurable I/O are included in a range of convenient pinouts.

The architecture for this device family, as shown in the [Logic Block Diagram on page 2](#), consists of three main areas:

- The Core
- CapSense Analog System
- System Resources (including a full-speed USB port).

A common, versatile bus allows connection between I/O and the analog system.

Each CY8C20X36A/46A/66A/96A/46AS/66AS PSoC device includes a dedicated CapSense block that provides sensing and scanning control circuitry for capacitive sensing applications. Depending on the PSoC package, up to 36 GPIO are also included. The GPIO provides access to the MCU and analog mux.

PSoC Core

The PSoC Core is a powerful engine that supports a rich instruction set. It encompasses SRAM for data storage, an interrupt controller, sleep and watchdog timers, and IMO and ILO. The CPU core, called the M8C, is a powerful processor with speeds up to 24 MHz. The M8C is a 4-MIPS, 8-bit Harvard-architecture microprocessor.

CapSense System

The analog system contains the capacitive sensing hardware. Several hardware algorithms are supported. This hardware performs capacitive sensing and scanning without requiring external components. The analog system is composed of the CapSense PSoC block and an internal 1 V or 1.2 V analog reference, which together support capacitive sensing of up to 33 inputs [3]. Capacitive sensing is configurable on each GPIO pin. Scanning of enabled CapSense pins is completed quickly and easily across multiple ports.

SmartSense

SmartSense is an innovative solution from Cypress that removes manual tuning of CapSense applications. This solution is easy to use and provides a robust noise immunity. It is the only auto-tuning solution that establishes, monitors, and maintains all

required tuning parameters. SmartSense allows engineers to go from prototyping to mass production without re-tuning for manufacturing variations in PCB and/or overlay material properties.

SmartSense_EMC

In addition to the SmartSense auto tuning algorithm to remove manual tuning of CapSense applications, SmartSense_EMC user module incorporates a unique algorithm to improve robustness of capacitive sensing algorithm/circuit against high frequency conducted and radiated noise. Every electronic device must comply with specific limits for radiated and conducted external noise and these limits are specified by regulatory bodies (for example, FCC, CE, U/L and so on). A very good PCB layout design, power supply design and system design is a mandatory for a product to pass the conducted and radiated noise tests. An ideal PCB layout, power supply design or system design is not often possible because of cost and form factor limitations of the product. SmartSense_EMC with superior noise immunity is well suited and handy for such applications to pass radiated and conducted noise test.

Figure 1. CapSense System Block Diagram

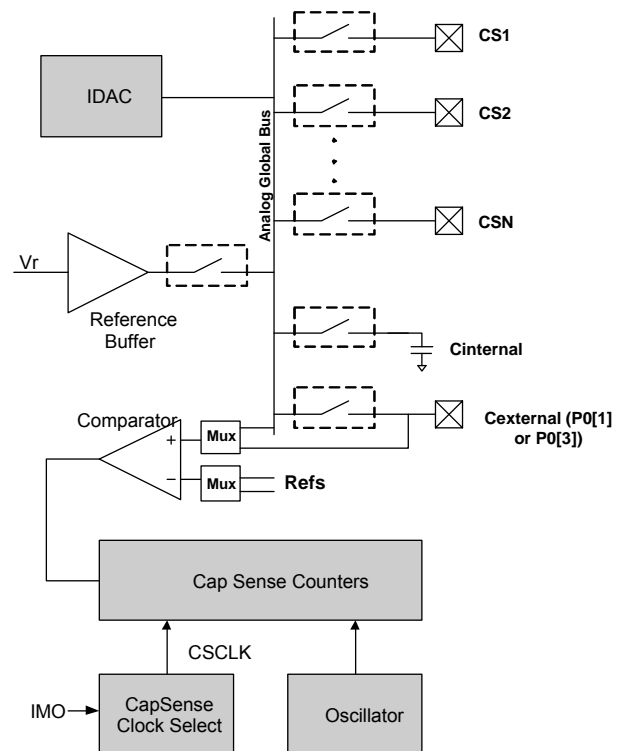

Note

3. 36 GPIOs = 33 pins for capacitive sensing + 2 pins for I²C + 1 pin for modulator capacitor.

Analog Multiplexer System

The Analog Mux Bus can connect to every GPIO pin. Pins are connected to the bus individually or in any combination. The bus also connects to the analog system for analysis with the CapSense block comparator.

Switch control logic enables selected pins to precharge continuously under hardware control. This enables capacitive measurement for applications such as touch sensing. Other multiplexer applications include:

- Complex capacitive sensing interfaces, such as sliders and touchpads.
- Chip-wide mux that allows analog input from any I/O pin.
- Crosspoint connection between any I/O pin combinations.

Additional System Resources

System resources provide additional capability, such as configurable USB and I²C slave, SPI master/slave

communication interface, three 16-bit programmable timers, and various system resets supported by the M8C.

These system resources provide additional capability useful to complete systems. Additional resources include low voltage detection and power on reset. The merits of each system resource are listed here:

- The I²C slave/SPI master-slave module provides 50/100/400 kHz communication over two wires. SPI communication over three or four wires runs at speeds of 46.9 kHz to 3 MHz (lower for a slower system clock).
- Low-voltage detection (LVD) interrupts can signal the application of falling voltage levels, while the advanced power-on-reset (POR) circuit eliminates the need for a system supervisor.
- An internal reference provides an absolute reference for capacitive sensing.
- A register-controlled bypass mode allows the user to disable the LDO regulator.

Getting Started

The quickest way to understand PSoC silicon is to read this datasheet and then use the PSoC Designer Integrated Development Environment (IDE). This datasheet is an overview of the PSoC integrated circuit and presents specific pin, register, and electrical specifications.

For in depth information, along with detailed programming details, see the [Technical Reference Manual](#) for the CY8C20X36A/46A/66A/96A/46AS/66AS PSoC devices.

For up-to-date ordering, packaging, and electrical specification information, see the latest PSoC device datasheets on the web at www.cypress.com/psoc.

CapSense Design Guides

Design Guides are an excellent introduction to the wide variety of possible CapSense designs. They are located at www.cypress.com/go/CapSenseDesignGuides.

Refer Getting Started with CapSense design guide for information on CapSense design and CY8C20XX6A/H/AS CapSense[®] Design Guide for specific information on CY8C20XX6A/AS CapSense controllers.

Silicon Errata

Errata documents known issues with silicon including errata trigger conditions, scope of impact, available workarounds and silicon revision applicability. Refer to Silicon Errata for the PSoC[®] CY8C20x36A/46A/66A/96A/46AS/66AS/36H/46H families available at <http://www.cypress.com/?rID=56239> for errata information on CY8C20xx6A/AS/H family of device. Compare

errata document with datasheet for a complete functional description of device.

Development Kits

[PSoC Development Kits](#) are available online from and through a growing number of regional and global distributors, which include Arrow, Avnet, Digi-Key, Farnell, Future Electronics, and Newark.

Training

[Free PSoC technical training](#) (on demand, webinars, and workshops), which is available online via www.cypress.com, covers a wide variety of topics and skill levels to assist you in your designs.

CYPros Consultants

Certified PSoC consultants offer everything from technical assistance to completed PSoC designs. To contact or become a PSoC consultant go to the [CYPros Consultants](#) web site.

Solutions Library

Visit our growing [library of solution focused designs](#). Here you can find various application designs that include firmware and hardware design files that enable you to complete your designs quickly.

Technical Support

[Technical support](#) – including a searchable Knowledge Base articles and technical forums – is also available online. If you cannot find an answer to your question, call our Technical Support hotline at 1-800-541-4736.

Development Tools

PSoC Designer™ is the revolutionary integrated design environment (IDE) that you can use to customize PSoC to meet your specific application requirements. PSoC Designer software accelerates system design and time to market. Develop your applications using a library of precharacterized analog and digital peripherals (called user modules) in a drag-and-drop design environment. Then, customize your design by leveraging the dynamically generated application programming interface (API) libraries of code. Finally, debug and test your designs with the integrated debug environment, including in-circuit emulation and standard software debug features. PSoC Designer includes:

- Application editor graphical user interface (GUI) for device and user module configuration and dynamic reconfiguration
- Extensive user module catalog
- Integrated source-code editor (C and assembly)
- Free C compiler with no size restrictions or time limits
- Built-in debugger
- In-circuit emulation
- Built-in support for communication interfaces:
 - Hardware and software I²C slaves and masters
 - Full-speed USB 2.0
 - Up to four full-duplex universal asynchronous receiver/transmitters (UARTs), SPI master and slave, and wireless

PSoC Designer supports the entire library of PSoC 1 devices and runs on Windows XP, Windows Vista, and Windows 7.

PSoC Designer Software Subsystems

Design Entry

In the chip-level view, choose a base device to work with. Then select different onboard analog and digital components that use the PSoC blocks, which are called user modules. Examples of user modules are analog-to-digital converters (ADCs), digital-to-analog converters (DACs), amplifiers, and filters. Configure the user modules for your chosen application and connect them to each other and to the proper pins. Then generate your project. This prepopulates your project with APIs and libraries that you can use to program your application.

The tool also supports easy development of multiple configurations and dynamic reconfiguration. Dynamic reconfiguration makes it possible to change configurations at run time. In essence, this lets you to use more than 100 percent of PSoC's resources for an application.

Code Generation Tools

The code generation tools work seamlessly within the PSoC Designer interface and have been tested with a full range of debugging tools. You can develop your design in C, assembly, or a combination of the two.

Assemblers. The assemblers allow you to merge assembly code seamlessly with C code. Link libraries automatically use absolute addressing or are compiled in relative mode, and linked with other software modules to get absolute addressing.

C Language Compilers. C language compilers are available that support the PSoC family of devices. The products allow you to create complete C programs for the PSoC family devices. The optimizing C compilers provide all of the features of C, tailored to the PSoC architecture. They come complete with embedded libraries providing port and bus operations, standard keypad and display support, and extended math functionality.

Debugger

PSoC Designer has a debug environment that provides hardware in-circuit emulation, allowing you to test the program in a physical system while providing an internal view of the PSoC device. Debugger commands allow you to read and program and read and write data memory, and read and write I/O registers. You can read and write CPU registers, set and clear breakpoints, and provide program run, halt, and step control. The debugger also lets you to create a trace buffer of registers and memory locations of interest.

Online Help System

The online help system displays online, context-sensitive help. Designed for procedural and quick reference, each functional subsystem has its own context-sensitive help. This system also provides tutorials and links to FAQs and an Online Support Forum to aid the designer.

In-Circuit Emulator

A low-cost, high-functionality in-circuit emulator (ICE) is available for development support. This hardware can program single devices.

The emulator consists of a base unit that connects to the PC using a USB port. The base unit is universal and operates with all PSoC devices. Emulation pods for each device family are available separately. The emulation pod takes the place of the PSoC device in the target board and performs full-speed (24 MHz) operation.

Designing with PSoC Designer

The development process for the PSoC device differs from that of a traditional fixed-function microprocessor. The configurable analog and digital hardware blocks give the PSoC architecture a unique flexibility that pays dividends in managing specification change during development and lowering inventory costs. These configurable resources, called PSoC blocks, have the ability to implement a wide variety of user-selectable functions. The PSoC development process is:

1. Select [user modules](#).
2. Configure user modules.
3. Organize and connect.
4. Generate, verify, and debug.

Select User Modules

PSoC Designer provides a library of prebuilt, pretested hardware peripheral components called “user modules”. User modules make selecting and implementing peripheral devices, both analog and digital, simple.

Configure User Modules

Each user module that you select establishes the basic register settings that implement the selected function. They also provide parameters and properties that allow you to tailor their precise configuration to your particular application. For example, a PWM User Module configures one or more digital PSoC blocks, one for each eight bits of resolution. Using these parameters, you can establish the pulse width and duty cycle. Configure the parameters and properties to correspond to your chosen application. Enter values directly or by selecting values from drop-down menus. All of the user modules are documented in datasheets that may be viewed directly in PSoC Designer or on the Cypress website. These [user module datasheets](#) explain the

internal operation of the user module and provide performance specifications. Each datasheet describes the use of each user module parameter, and other information that you may need to successfully implement your design.

Organize and Connect

Build signal chains at the chip level by interconnecting user modules to each other and the I/O pins. Perform the selection, configuration, and routing so that you have complete control over all on-chip resources.

Generate, Verify, and Debug

When you are ready to test the hardware configuration or move on to developing code for the project, perform the “Generate Configuration Files” step. This causes PSoC Designer to generate source code that automatically configures the device to your specification and provides the software for the system. The generated code provides APIs with high-level functions to control and respond to hardware events at run time, and interrupt service routines that you can adapt as needed.

A complete code development environment lets you to develop and customize your applications in C, assembly language, or both.

The last step in the development process takes place inside PSoC Designer’s Debugger (accessed by clicking the Connect icon). PSoC Designer downloads the HEX image to the ICE where it runs at full-speed. PSoC Designer debugging capabilities rival those of systems costing many times more. In addition to traditional single-step, run-to-breakpoint, and watch-variable features, the debug interface provides a large trace buffer. It lets you to define complex breakpoint events that include monitoring address and data bus values, memory locations, and external signals.

Pinouts

The CY8C20X36A/46A/66A/96A/46AS/66AS PSoC device is available in a variety of packages, which are listed and illustrated in the following tables. Every port pin (labeled with a “P”) is capable of Digital I/O and connection to the common analog bus. However, V_{SS}, V_{DD}, and XRES are not capable of Digital I/O.

16-pin QFN (12 Sensing Inputs)^[4]

Table 1. Pin Definitions – CY8C20236A, CY8C20246A, CY8C20246AS PSoC Device

Pin No.	Type		Name	Description
	Digital	Analog		
1	I/O	I	P2[5]	Crystal output (XOut)
2	I/O	I	P2[3]	Crystal input (XIn)
3	IOHR	I	P1[7]	I ² C SCL, SPI SS
4	IOHR	I	P1[5]	I ² C SDA, SPI MISO
5	IOHR	I	P1[3]	SPI CLK
6	IOHR	I	P1[1]	ISSP CLK ^[5] , I ² C SCL, SPI MOSI
7	Power		V _{SS}	Ground connection
8	IOHR	I	P1[0]	ISSP DATA ^[5] , I ² C SDA, SPI CLK ^[6]
9	IOHR	I	P1[2]	
10	IOHR	I	P1[4]	Optional external clock (EXTCLK)
11	Input		XRES	Active high external reset with internal pull-down
12	IOH	I	P0[4]	
13	Power		V _{DD}	Supply voltage
14	IOH	I	P0[7]	
15	IOH	I	P0[3]	Integrating input
16	IOH	I	P0[1]	Integrating input

Figure 2. CY8C20236A, CY8C20246A, CY8C20246AS

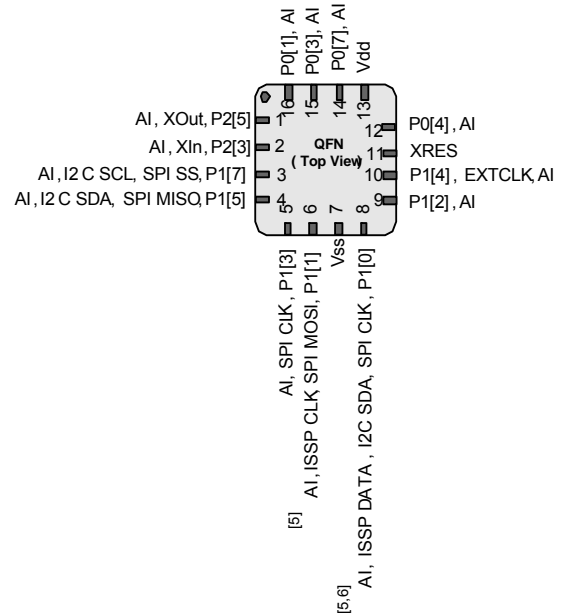

LEGEND A = Analog, I = Input, O = Output, OH = 5 mA High Output Drive, R = Regulated Output.

Notes

- No Center Pad.
- On power-up, the SDA(P1[0]) drives a strong high for 256 sleep clock cycles and drives resistive low for the next 256 sleep clock cycles. The SCL(P1[1]) line drives resistive low for 512 sleep clock cycles and both the pins transition to high impedance state. On reset, after XRES de-asserts, the SDA and the SCL lines drive resistive low for 8 sleep clock cycles and transition to high impedance state. Hence, during power-up or reset event, P1[1] and P1[0] may disturb the I2C bus. Use alternate pins if you encounter issues.
- Alternate SPI clock.

24-pin QFN (12 Sensing Inputs)

Table 2. Pin Definitions – CY8C20336A, CY8C20346A, CY8C20346AS [7]

Pin No.	Type		Name	Description
	Digital	Analog		
1	I/O	I	P2[5]	Crystal output (XOut)
2	I/O	I	P2[3]	Crystal input (XIn)
3	I/O	I	P2[1]	
4	IOHR	I	P1[7]	I ² C SCL, SPI SS
5	IOHR	I	P1[5]	I ² C SDA, SPI MISO
6	IOHR	I	P1[3]	SPI CLK
7	IOHR	I	P1[1]	ISSP CLK ^[8] , I ² C SCL, SPI MOSI
8			NC	No connection
9	Power		V _{SS}	Ground connection
10	IOHR	I	P1[0]	ISSP DATA ^[8] , I ² C SDA, SPI CLK ^[9]
11	IOHR	I	P1[2]	
12	IOHR	I	P1[4]	Optional external clock input (EXTCLK)
13	IOHR	I	P1[6]	
14	Input		XRES	Active high external reset with internal pull-down
15	I/O	I	P2[0]	
16	IOH	I	P0[0]	
17	IOH	I	P0[2]	
18	IOH	I	P0[4]	
19	IOH	I	P0[6]	
20	Power		V _{DD}	Supply voltage
21	IOH	I	P0[7]	
22	IOH	I	P0[5]	
23	IOH	I	P0[3]	Integrating input
24	IOH	I	P0[1]	Integrating input
CP	Power		V _{SS}	Center pad must be connected to ground

Figure 3. CY8C20336A, CY8C20346A, CY8C20346AS

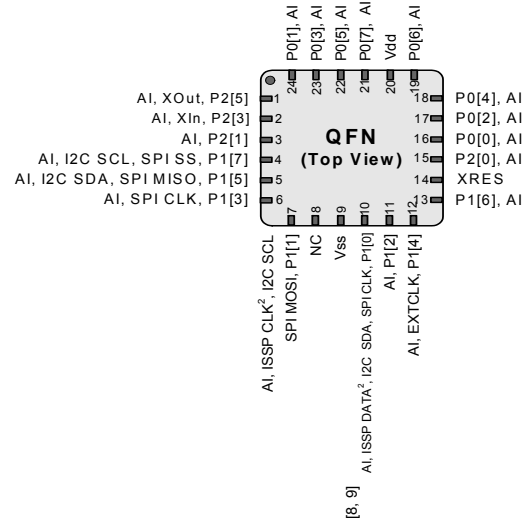

LEGEND A = Analog, I = Input, O = Output, OH = 5 mA High Output Drive, R = Regulated Output.

Notes

- The center pad (CP) on the QFN package must be connected to ground (V_{SS}) for best mechanical, thermal, and electrical performance. If not connected to ground, it must be electrically floated and not connected to any other signal.
- On power-up, the SDA(P1[0]) drives a strong high for 256 sleep clock cycles and drives resistive low for the next 256 sleep clock cycles. The SCL(P1[1]) line drives resistive low for 512 sleep clock cycles and both the pins transition to high impedance state. On reset, after XRES de-asserts, the SDA and the SCL lines drive resistive low for 8 sleep clock cycles and transition to high impedance state. Hence, during power-up or reset event, P1[1] and P1[0] may disturb the I2C bus. Use alternate pins if you encounter issues.
- Alternate SPI clock.

24-pin QFN - 18 Sensing Inputs (With USB)

Table 3. Pin Definitions – CY8C20396A [10]

Pin No.	Type		Name	Description
	Digital	Analog		
1	I/O	I	P2[5]	
2	I/O	I	P2[3]	
3	I/O	I	P2[1]	
4	IOHR	I	P1[7]	I ² C SCL, SPI SS
5	IOHR	I	P1[5]	I ² C SDA, SPI MISO
6	IOHR	I	P1[3]	SPI CLK
7	IOHR	I	P1[1]	ISSP CLK ^[11] , I ² C SCL, SPI MOSI
8	Power		V _{SS}	Ground
9	I/O	I	D+	USB D+
10	I/O	I	D-	USB D-
11	Power		V _{DD}	Supply
12	IOHR	I	P1[0]	ISSP DATA ^[11] , I ² C SDA, SPI CLK ^[12]
13	IOHR	I	P1[2]	
14	IOHR	I	P1[4]	Optional external clock input (EXTCLK)
15	IOHR	I	P1[6]	
16	RESET INPUT		XRES	Active high external reset with internal pull-down
17	IOH	I	P0[0]	
18	IOH	I	P0[2]	
19	IOH	I	P0[4]	
20	IOH	I	P0[6]	
21	IOH	I	P0[7]	
22	IOH	I	P0[5]	
23	IOH	I	P0[3]	Integrating input
24	IOH	I	P0[1]	Integrating input
CP	Power		V _{SS}	Center pad must be connected to Ground

Figure 4. CY8C20396A

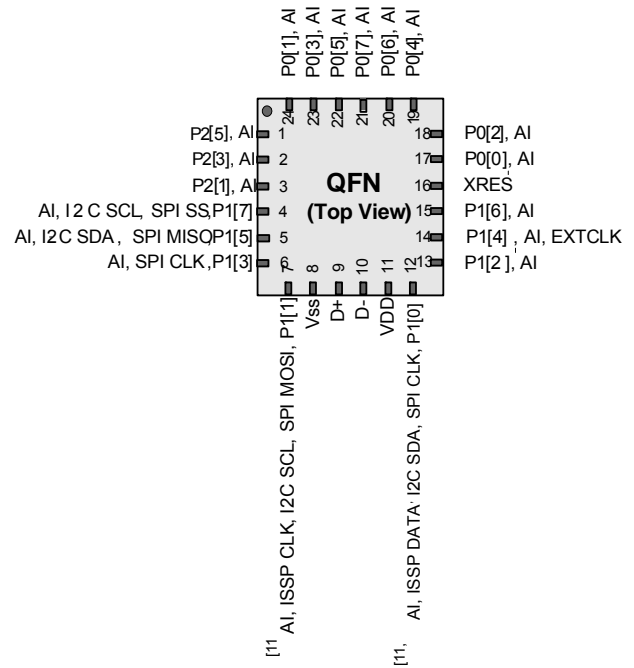

LEGEND I = Input, O = Output, OH = 5 mA High Output Drive, R = Regulated Output

Notes

- 10. The center pad (CP) on the QFN package must be connected to ground (V_{SS}) for best mechanical, thermal, and electrical performance. If not connected to ground, it must be electrically floated and not connected to any other signal.
- 11. On power-up, the SDA(P1[0]) drives a strong high for 256 sleep clock cycles and drives resistive low for the next 256 sleep clock cycles. The SCL(P1[1]) line drives resistive low for 512 sleep clock cycles and both the pins transition to high impedance state. On reset, after XRES de-asserts, the SDA and the SCL lines drive resistive low for 8 sleep clock cycles and transition to high impedance state. Hence, during power-up or reset event, P1[1] and P1[0] may disturb the I2C bus. Use alternate pins if you encounter issues.
- 12. Alternate SPI clock.

30-ball WLCSP (26 Sensing Inputs)
Table 4. Pin Definitions – CY8C20766A, CY8C20746A 30-ball WLCSP

Pin No.	Type		Name	Description
	Digital	Analog		
A1	IOH	I	P0[2]	
A2	IOH	I	P0[6]	
A3	Power		V _{DD}	Supply voltage
A4	IOH	I	P0[1]	Integrating Input
A5	I/O	I	P2[7]	
B1	I/O	I	P2[6]	
B2	IOH	I	P0[0]	
B3	IOH	I	P0[4]	
B4	IOH	I	P0[3]	Integrating Input
B5	I/O	I	P2[5]	Crystal Output (Xout)
C1	I/O	I	P2[2]	
C2	I/O	I	P2[4]	
C3	IOH	I	P0[7]	
C4	IOH	I	P0[5]	
C5	I/O	I	P2[3]	Crystal Input (Xin)
D1	I/O	I	P2[0]	
D2	I/O	I	P3[0]	
D3	I/O	I	P3[1]	
D4	I/O	I	P3[3]	
D5	I/O	I	P2[1]	
E1	Input		XRES	Active high external reset with internal pull-down
E2	IOHR	I	P1[6]	
E3	IOHR	I	P1[4]	Optional external clock input (EXT CLK)
E4	IOHR	I	P1[7]	I ² C SCL, SPI SS
E5	IOHR	I	P1[5]	I ² C SDA, SPI MISO
F1	IOHR	I	P1[2]	
F2	IOHR	I	P1[0]	ISSP DATA ^[13] , I ² C SDA, SPI CLK ^[14]
F3	Power		V _{SS}	Supply ground
F4	IOHR	I	P1[1]	ISSP CLK ^[13] , I ² C SCL, SPI MOSI
F5	IOHR	I	P1[3]	SPI CLK

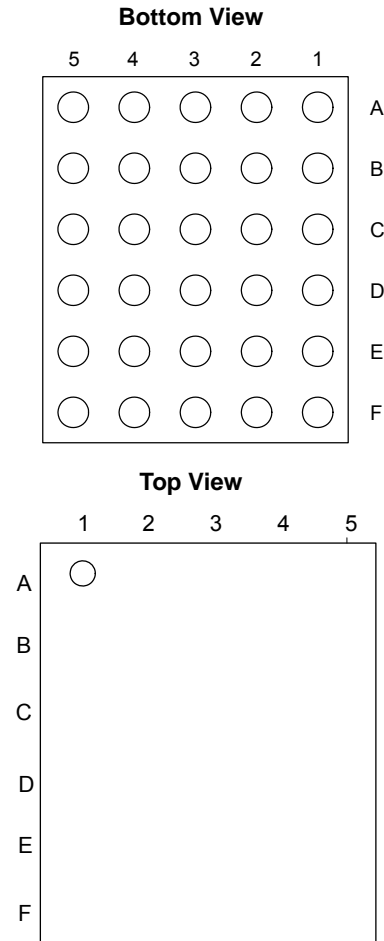
Figure 5. CY8C20766A 30-ball WLCSP

Notes

13. On power-up, the SDA(P1[0]) drives a strong high for 256 sleep clock cycles and drives resistive low for the next 256 sleep clock cycles. The SCL(P1[1]) line drives resistive low for 512 sleep clock cycles and both the pins transition to high impedance state. On reset, after XRES de-asserts, the SDA and the SCL lines drive resistive low for 8 sleep clock cycles and transition to high impedance state. Hence, during power-up or reset event, P1[1] and P1[0] may disturb the I2C bus. Use alternate pins if you encounter issues.

14. Alternate SPI clock.

32-pin QFN (27 Sensing Inputs)

Table 5. Pin Definitions – CY8C20436A, CY8C20446A, CY8C20446AS, CY8C20466A, CY8C20466AS^[15]

Pin No.	Type		Name	Description
	Digital	Analog		
1	IOH	I	P0[1]	Integrating input
2	I/O	I	P2[7]	
3	I/O	I	P2[5]	Crystal output (XOut)
4	I/O	I	P2[3]	Crystal input (XIn)
5	I/O	I	P2[1]	
6	I/O	I	P3[3]	
7	I/O	I	P3[1]	
8	IOHR	I	P1[7]	I ² C SCL, SPI SS
9	IOHR	I	P1[5]	I ² C SDA, SPI MISO
10	IOHR	I	P1[3]	SPI CLK.
11	IOHR	I	P1[1]	ISSP CLK ^[16] , I ² C SCL, SPI MOSI.
12	Power		V _{SS}	Ground connection.
13	IOHR	I	P1[0]	ISSP DATA ^[16] , I ² C SDA, SPI CLK ^[17]
14	IOHR	I	P1[2]	
15	IOHR	I	P1[4]	Optional external clock input (EXTCLK)
16	IOHR	I	P1[6]	
17	Input		XRES	Active high external reset with internal pull-down
18	I/O	I	P3[0]	
19	I/O	I	P3[2]	
20	I/O	I	P2[0]	
21	I/O	I	P2[2]	
22	I/O	I	P2[4]	
23	I/O	I	P2[6]	
24	IOH	I	P0[0]	
25	IOH	I	P0[2]	
26	IOH	I	P0[4]	
27	IOH	I	P0[6]	
28	Power		V _{DD}	Supply voltage
29	IOH	I	P0[7]	
30	IOH	I	P0[5]	
31	IOH	I	P0[3]	Integrating input
32	Power		V _{SS}	Ground connection
CP	Power		V _{SS}	Center pad must be connected to ground

LEGEND A = Analog, I = Input, O = Output, OH = 5 mA High Output Drive, R = Regulated Output.

Notes

- The center pad (CP) on the QFN package must be connected to ground (V_{SS}) for best mechanical, thermal, and electrical performance. If not connected to ground, it must be electrically floated and not connected to any other signal.
- On power-up, the SDA(P1[0]) drives a strong high for 256 sleep clock cycles and drives resistive low for the next 256 sleep clock cycles. The SCL(P1[1]) line drives resistive low for 512 sleep clock cycles and both the pins transition to high impedance state. On reset, after XRES de-asserts, the SDA and the SCL lines drive resistive low for 8 sleep clock cycles and transition to high impedance state. Hence, during power-up or reset event, P1[1] and P1[0] may disturb the I2C bus. Use alternate pins if you encounter issues.
- Alternate SPI clock.

Figure 6. CY8C20436A, CY8C20446A, CY8C20446AS, CY8C20466A, CY8C20466AS

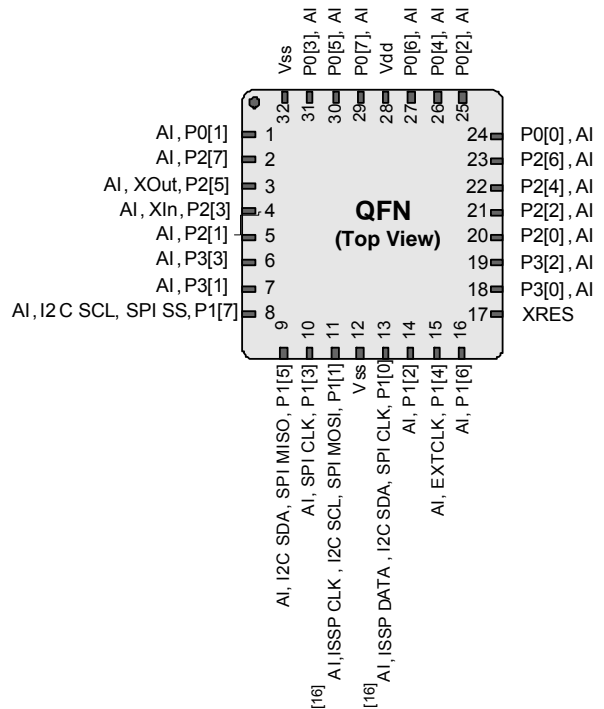

32-pin QFN - 24 Sensing Inputs (With USB)

Table 6. Pin Definitions – CY8C20496A^[18]

Pin No.	Type		Name	Description
	Digital	Analog		
1	IOH	I	P0[1]	Integrating Input
2	I/O	I	P2[5]	XTAL Out
3	I/O	I	P2[3]	XTAL In
4	I/O	I	P2[1]	
5	IOHR	I	P1[7]	I ² C SCL, SPI SS
6	IOHR	I	P1[5]	I ² C SDA, SPI MISO
7	IOHR	I	P1[3]	SPI CLK
8	IOHR	I	P1[1]	ISSP CLK ^[19] , I ² C SCL, SPI MOSI
9	Power		V _{SS}	Ground Pin
10	I		D+	USB D+
11			D-	USB D-
12	Power		V _{DD}	Power pin
13	IOHR	I	P1[0]	ISSP DATA ^[19] , I ² C SDA, SPI CLK ^[20]
14	IOHR	I	P1[2]	
15	IOHR	I	P1[4]	Optional external clock input (EXTCLK)
16	IOHR	I	P1[6]	
17	Input		XRES	Active high external reset with internal pull-down
18	I/O	I	P3[0]	
19	I/O	I	P3[2]	
20	I/O	I	P2[0]	
21	I/O	I	P2[2]	
22	I/O	I	P2[4]	
23	I/O	I	P2[6]	
24	IOH	I	P0[0]	
25	IOH	I	P0[2]	
26	IOH	I	P0[4]	
27	IOH	I	P0[6]	
28	Power		V _{DD}	Power Pin
29	IOH	I	P0[7]	
30	IOH	I	P0[5]	
31	IOH	I	P0[3]	Integrating Input
32	Power		V _{SS}	Ground Pin

Figure 7. CY8C20496A

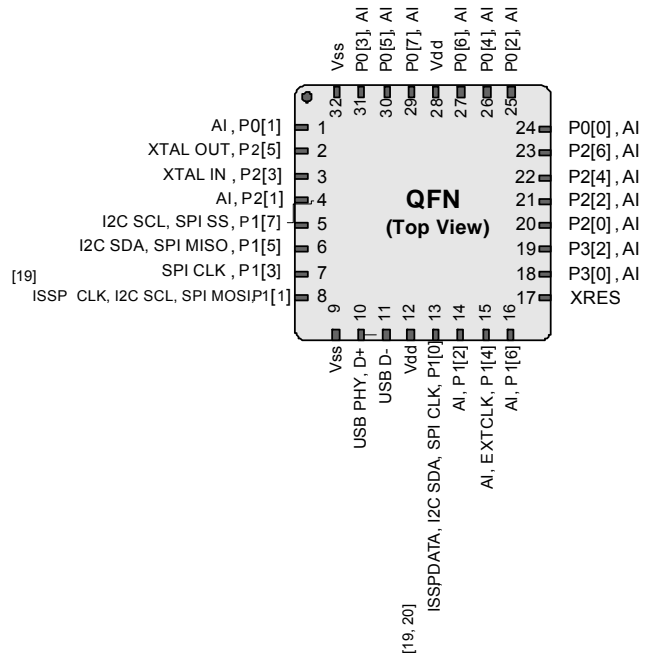

LEGEND A = Analog, I = Input, O = Output, OH = 5 mA High Output Drive, R = Regulated Output.

Notes

- The center pad (CP) on the QFN package must be connected to ground (V_{SS}) for best mechanical, thermal, and electrical performance. If not connected to ground, it must be electrically floated and not connected to any other signal.
- On power-up, the SDA(P1[0]) drives a strong high for 256 sleep clock cycles and drives resistive low for the next 256 sleep clock cycles. The SCL(P1[1]) line drives resistive low for 512 sleep clock cycles and both the pins transition to high impedance state. On reset, after XRES de-asserts, the SDA and the SCL lines drive resistive low for 8 sleep clock cycles and transition to high impedance state. Hence, during power-up or reset event, P1[1] and P1[0] may disturb the I2C bus. Use alternate pins if you encounter issues.
- Alternate SPI clock.

48-pin SSOP (33 Sensing Inputs)

Table 7. Pin Definitions – CY8C20536A, CY8C20546A, and CY8C20566A^[21]

Pin No.	Digital	Analog	Name	Description
1	IOH	I	P0[7]	
2	IOH	I	P0[5]	
3	IOH	I	P0[3]	Integrating Input
4	IOH	I	P0[1]	Integrating Input
5	I/O	I	P2[7]	
6	I/O	I	P2[5]	XTAL Out
7	I/O	I	P2[3]	XTAL In
8	I/O	I	P2[1]	
9			NC	No connection
10			NC	No connection
11	I/O	I	P4[3]	
12	I/O	I	P4[1]	
13			NC	No connection
14	I/O	I	P3[7]	
15	I/O	I	P3[5]	
16	I/O	I	P3[3]	
17	I/O	I	P3[1]	
18			NC	No connection
19			NC	No connection
20	IOHR	I	P1[7]	I ² C SCL, SPI SS
21	IOHR	I	P1[5]	I ² C SDA, SPI MISO
22	IOHR	I	P1[3]	SPI CLK
23	IOHR	I	P1[1]	ISSP CLK ^[21] , I ² C SCL, SPI MOSI
24			V _{SS}	Ground Pin
25	IOHR	I	P1[0]	ISSP DATA ^[21] , I ² C SDA, SPI CLK ^[22]
26	IOHR	I	P1[2]	
27	IOHR	I	P1[4]	Optional external clock input (EXT CLK)
28	IOHR	I	P1[6]	
29			NC	No connection
30			NC	No connection
31			NC	No connection
32			NC	No connection
33			NC	No connection
34			NC	No connection
35			XRES	Active high external reset with internal pull-down
36	I/O	I	P3[0]	
37	I/O	I	P3[2]	
38	I/O	I	P3[4]	
39	I/O	I	P3[6]	
40	I/O	I	P2[0]	
41	I/O	I	P2[2]	
42	I/O	I	P2[4]	
43	I/O	I	P2[6]	
44	IOH	I	P0[0]	
45	IOH	I	P0[2]	
46	IOH	I	P0[4]	VREF
47	IOH	I	P0[6]	
48	Power		V _{DD}	Power Pin

Figure 8. CY8C20536A, CY8C20546A, and CY8C20566A

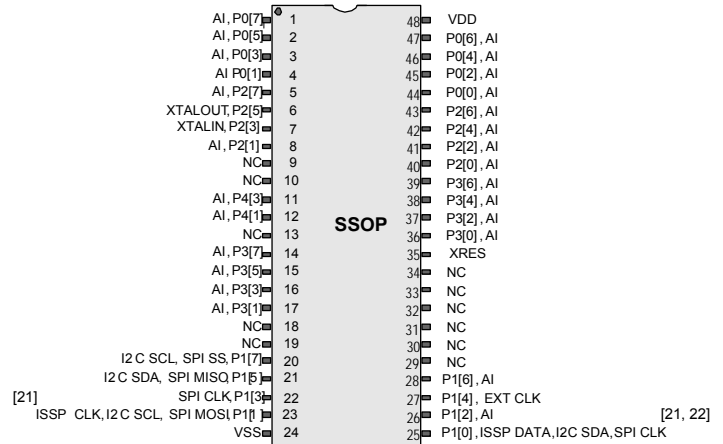

LEGEND A = Analog, I = Input, O = Output, NC = No Connection, H = 5 mA High Output Drive, R = Regulated Output Option.

Notes

- On power-up, the SDA(P1[0]) drives a strong high for 256 sleep clock cycles and drives resistive low for the next 256 sleep clock cycles. The SCL(P1[1]) line drives resistive low for 512 sleep clock cycles and both the pins transition to high impedance state. On reset, after XRES de-asserts, the SDA and the SCL lines drive resistive low for 8 sleep clock cycles and transition to high impedance state. Hence, during power-up or reset event, P1[1] and P1[0] may disturb the I2C bus. Use alternate pins if you encounter issues.
- Alternate SPI clock.

48-pin QFN (35 Sensing Inputs)

Table 8. Pin Definitions – CY8C20636A^[23, 24]

Pin No.	Digital	Analog	Name	Description	
1			NC	No connection	
2	I/O	I	P2[7]		
3	I/O	I	P2[5]	Crystal output (XOut)	
4	I/O	I	P2[3]	Crystal input (XIn)	
5	I/O	I	P2[1]		
6	I/O	I	P4[3]		
7	I/O	I	P4[1]		
8	I/O	I	P3[7]		
9	I/O	I	P3[5]		
10	I/O	I	P3[3]		
11	I/O	I	P3[1]		
12	IOHR	I	P1[7]	I ² C SCL, SPI SS	
13	IOHR	I	P1[5]	I ² C SDA, SPI MISO	
14			NC	No connection	
15			NC	No connection	
16	IOHR	I	P1[3]	SPI CLK	
17	IOHR	I	P1[1]	ISSP CLK ^[23] , I ² C SCL, SPI MOSI	
18		Power	V _{SS}	Ground connection	
19			DNU		
20			DNU		
21		Power	V _{DD}	Supply voltage	
22	IOHR	I	P1[0]	ISSP DATA ^[23] , I ² C SDA, SPI CLK ^[25]	
23	IOHR	I	P1[2]		
24	IOHR	I	P1[4]	Optional external clock input (EXTCLK)	
25	IOHR	I	P1[6]		
26		Input	XRES	Active high external reset with internal pull-down	
27	I/O	I	P3[0]		
28	I/O	I	P3[2]		
29	I/O	I	P3[4]		
30	I/O	I	P3[6]		
31	I/O	I	P4[0]		
32	I/O	I	P4[2]		
33	I/O	I	P2[0]		
34	I/O	I	P2[2]		
35	I/O	I	P2[4]		
36	I/O	I	P2[6]		
37	IOH	I	P0[2]		
38	IOH	I	P0[1]		
39	IOH	I	P0[4]		
	Pin No.	Digital	Analog	Name	Description
	40	IOH	I	P0[6]	
	41		Power	V _{DD}	Supply voltage
	42			NC	No connection
	43			NC	No connection
	44	IOH	I	P0[7]	
	45	IOH	I	P0[5]	
	46	IOH	I	P0[3]	Integrating input
	47		Power	V _{SS}	Ground connection
	48	IOH	I	P0[1]	
	CP		Power	V _{SS}	Center pad must be connected to ground

LEGEND A = Analog, I = Input, O = Output, NC = No Connection H = 5 mA High Output Drive, R = Regulated Output.

Figure 9. CY8C20636A

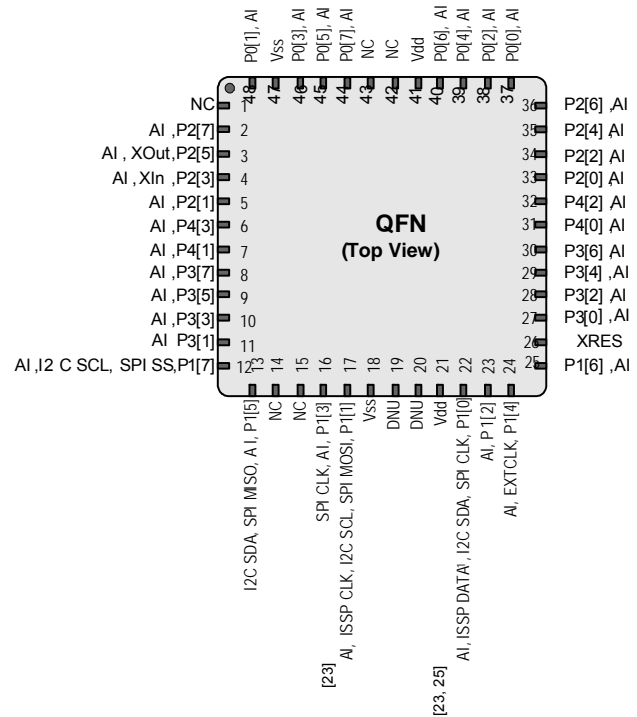

Notes

- On power-up, the SDA(P1[0]) drives a strong high for 256 sleep clock cycles and drives resistive low for the next 256 sleep clock cycles. The SCL(P1[1]) line drives resistive low for 512 sleep clock cycles and both the pins transition to high impedance state. On reset, after XRES de-asserts, the SDA and the SCL lines drive resistive low for 8 sleep clock cycles and transition to high impedance state. Hence, during power-up or reset event, P1[1] and P1[0] may disturb the I2C bus. Use alternate pins if you encounter issues.
- The center pad (CP) on the QFN package must be connected to ground (V_{SS}) for best mechanical, thermal, and electrical performance. If not connected to ground, it must be electrically floated and not connected to any other signal
- Alternate SPI clock.

48-pin QFN - 35 Sensing Inputs (With USB)

Table 9. Pin Definitions – CY8C20646A, CY8C20646AS, CY8C20666A, CY8C20666AS [26, 27]

Pin No.	Digital	Analog	Name	Description
1			NC	No connection
2	I/O	I	P2[7]	
3	I/O	I	P2[5]	Crystal output (XOut)
4	I/O	I	P2[3]	Crystal input (XIn)
5	I/O	I	P2[1]	
6	I/O	I	P4[3]	
7	I/O	I	P4[1]	
8	I/O	I	P3[7]	
9	I/O	I	P3[5]	
10	I/O	I	P3[3]	
11	I/O	I	P3[1]	
12	IOHR	I	P1[7]	I ² C SCL, SPI SS
13	IOHR	I	P1[5]	I ² C SDA, SPI MISO
14			NC	No connection
15			NC	No connection
16	IOHR	I	P1[3]	SPI CLK
17	IOHR	I	P1[1]	ISSP CLK ^[26] , I ² C SCL, SPI MOSI
18	Power		V _{SS}	Ground connection
19	I/O		D+	USB D+
20	I/O		D-	USB D-
21	Power		V _{DD}	Supply voltage
22	IOHR	I	P1[0]	ISSP DATA ^[26] , I ² C SDA, SPI CLK ^[28]
23	IOHR	I	P1[2]	
24	IOHR	I	P1[4]	Optional external clock input (EXTCLK)
25	IOHR	I	P1[6]	
26	Input		XRES	Active high external reset with internal pull-down
27	I/O	I	P3[0]	
28	I/O	I	P3[2]	
29	I/O	I	P3[4]	
30	I/O	I	P3[6]	
31	I/O	I	P4[0]	
32	I/O	I	P4[2]	
33	I/O	I	P2[0]	
34	I/O	I	P2[2]	
35	I/O	I	P2[4]	
36	I/O	I	P2[6]	
37	IOH	I	P0[0]	
38	IOH	I	P0[2]	
39	IOH	I	P0[4]	
Pin No.	Digital	Analog	Name	Description
40	IOH	I	P0[6]	
41	Power		V _{DD}	Supply voltage
42			NC	No connection
43			NC	No connection
44	IOH	I	P0[7]	
45	IOH	I	P0[5]	
46	IOH	I	P0[3]	Integrating input
47	Power		V _{SS}	Ground connection
48	IOH	I	P0[1]	
CP	Power		V _{SS}	Center pad must be connected to ground

LEGEND A = Analog, I = Input, O = Output, NC = No Connection H = 5 mA High Output Drive, R = Regulated Output.

Figure 10. CY8C20646A, CY8C20646AS, CY8C20666A, CY8C20666AS

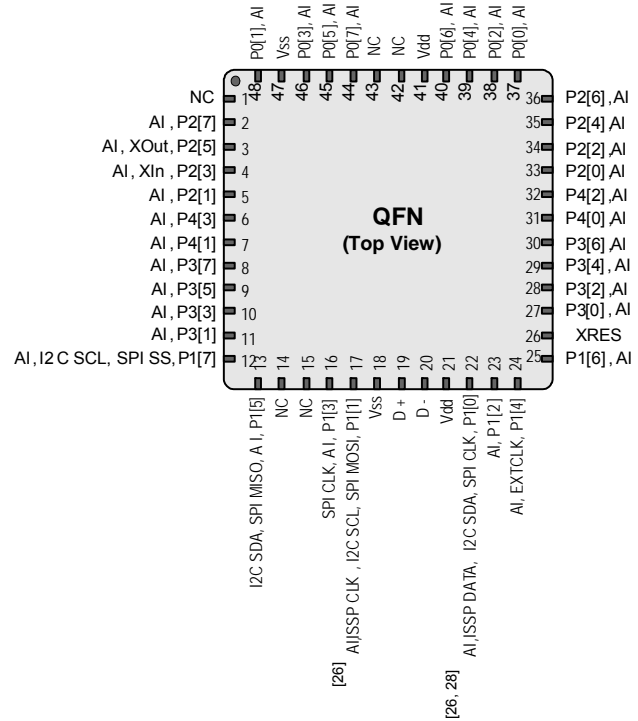

Notes

- On Power-up, the SDA(P1[0]) drives a strong high for 256 sleep clock cycles and drives resistive low for the next 256 sleep clock cycles. The SCL(P1[1]) line drives resistive low for 512 sleep clock cycles and both the pins transition to High impedance state. On reset, after XRES de-asserts, the SDA and the SCL lines drive resistive low for 8 sleep clock cycles and transition to high impedance state. In both cases, a pull-up resistance on these lines combines with the pull-down resistance (5.6K ohm) and form a potential divider. Hence, during power-up or reset event, P1[1] and P1[0] may disturb the I2C bus. Use alternate pins if you encounter issues.
- The center pad (CP) on the QFN package must be connected to ground (V_{SS}) for best mechanical, thermal, and electrical performance. If not connected to ground, it must be electrically floated and not connected to any other signal.
- Alternate SPI clock.

48-pin QFN (OCD)

The 48-pin QFN part is for the CY8C20066A On-Chip Debug (OCD). Note that this part is only used for in-circuit debugging.

Table 10. Pin Definitions – CY8C20066A [29, 30]

Pin No.	Digital	Analog	Name	Description
1 ^[31]			OCDOE	OCD mode direction pin
2	I/O	I	P2[7]	
3	I/O	I	P2[5]	Crystal output (XOut)
4	I/O	I	P2[3]	Crystal input (XIn)
5	I/O	I	P2[1]	
6	I/O	I	P4[3]	
7	I/O	I	P4[1]	
8	I/O	I	P3[7]	
9	I/O	I	P3[5]	
10	I/O	I	P3[3]	
11	I/O	I	P3[1]	
12	IOHR	I	P1[7]	I ² C SCL, SPI SS
13	IOHR	I	P1[5]	I ² C SDA, SPI MISO
14 ^[31]			CCLK	OCD CPU clock output
15 ^[31]			HCLK	OCD high speed clock output
16	IOHR	I	P1[3]	SPI CLK.
17	IOHR	I	P1[1]	ISSP CLK ^[32] , I ² C SCL, SPI MOSI
18	Power		V _{SS}	Ground connection
19	I/O		D+	USB D+
20	I/O		D-	USB D-
21	Power		V _{DD}	Supply voltage
22	IOHR	I	P1[0]	ISSP DATA ^[32] , I ² C SDA, SPI CLK ^[33]
23	IOHR	I	P1[2]	
24	IOHR	I	P1[4]	Optional external clock input (EXTCLK)
25	IOHR	I	P1[6]	
26	Input		XRES	Active high external reset with internal pull-down
27	I/O	I	P3[0]	
28	I/O	I	P3[2]	
29	I/O	I	P3[4]	
30	I/O	I	P3[6]	
31	I/O	I	P4[0]	
32	I/O	I	P4[2]	
33	I/O	I	P2[0]	
34	I/O	I	P2[2]	
35	I/O	I	P2[4]	
36	I/O	I	P2[6]	

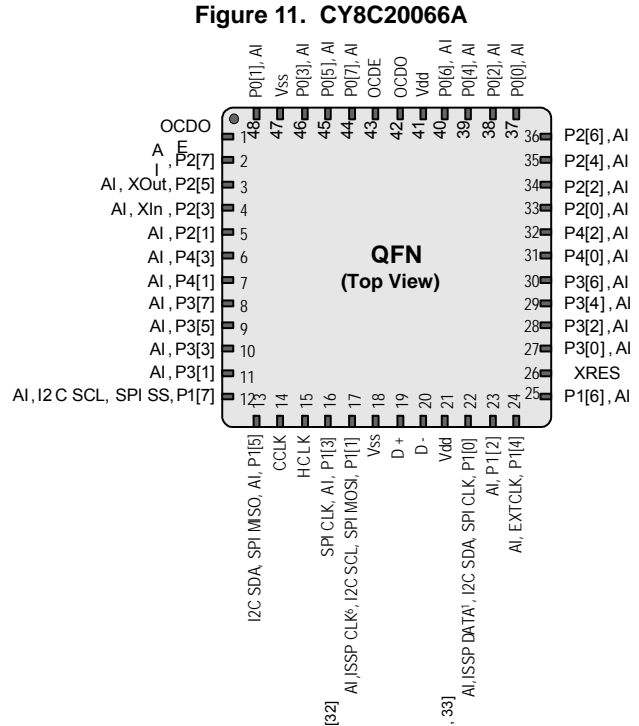

LEGEND A = Analog, I = Input, O = Output, NC = No Connection H = 5 mA High Output Drive, R = Regulated Output.

Notes

- This part is available in limited quantities for In-Circuit Debugging during prototype development. It is not available in production volumes.
- The center pad (CP) on the QFN package must be connected to ground (V_{SS}) for best mechanical, thermal, and electrical performance. If not connected to ground, it must be electrically floated and not connected to any other signal.
- This pin (associated with OCD part only) is required for connecting the device to ICE-Cube In-Circuit Emulator for firmware debugging purpose. To know more about the usage of ICE-Cube, refer to [CY3215-DK PSoC® IN-CIRCUIT EMULATOR KIT GUIDE](#).
- On Power-up, the SDA(P1[0]) drives a strong high for 256 sleep clock cycles and drives resistive low for the next 256 sleep clock cycles. The SCL(P1[1]) line drives resistive low for 512 sleep clock cycles and both the pins transition to High impedance state. On reset, after XRES de-asserts, the SDA and the SCL lines drive resistive low for 8 sleep clock cycles and transition to high impedance state. In both cases, a pull-up resistance on these lines combines with the pull-down resistance (5.6K ohm) and form a potential divider. Hence, during power-up or reset event, P1[1] and P1[0] may disturb the I2C bus. Use alternate pins if you encounter issues.
- Alternate SPI clock.

Electrical Specifications

This section presents the DC and AC electrical specifications of the CY8C20X36A/46A/66A/96A/46AS/66AS PSoC devices. For the latest electrical specifications, confirm that you have the most recent datasheet by visiting the web at <http://www.cypress.com/psoc>.

Figure 12. Voltage versus CPU Frequency

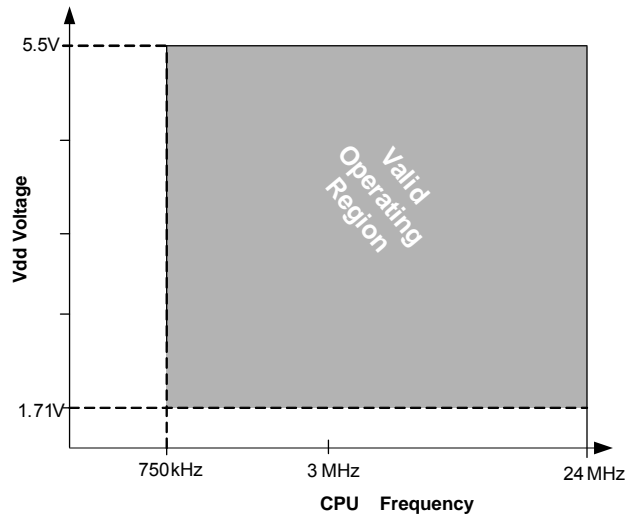

Absolute Maximum Ratings

Exceeding maximum ratings may shorten the useful life of the device. User guidelines are not tested.

Table 11. Absolute Maximum Ratings

Symbol	Description	Conditions	Min	Typ	Max	Units
T _{STG}	Storage temperature	Higher storage temperatures reduce data retention time. Recommended Storage Temperature is +25 °C ± 25 °C. Extended duration storage temperatures above 85 °C degrades reliability.	-55	+25	+125	°C
V _{DD}	Supply voltage relative to V _{SS}	-	-0.5	-	+6.0	V
V _{IO}	DC input voltage	-	V _{SS} - 0.5	-	V _{DD} + 0.5	V
V _{IOZ} ^[34]	DC voltage applied to tristate	-	V _{SS} - 0.5	-	V _{DD} + 0.5	V
I _{MIO}	Maximum current into any port pin	-	-25	-	+50	mA
ESD	Electrostatic discharge voltage	Human body model ESD	2000	-	-	V
LU	Latch-up current	In accordance with JESD78 standard	-	-	200	mA

Operating Temperature

Table 12. Operating Temperature

Symbol	Description	Conditions	Min	Typ	Max	Units
T _A	Ambient temperature	-	-40	-	+85	°C
T _C	Commercial temperature range	-	0	-	70	°C
T _J	Operational die temperature	The temperature rise from ambient to junction is package specific. Refer the Thermal Impedances on page 37 . The user must limit the power consumption to comply with this requirement.	-40	-	+100	°C

Note

34. Port1 pins are hot-swap capable with I/O configured in High-Z mode, and pin input voltage above V_{DD}.

DC Chip-Level Specifications

The following table lists guaranteed maximum and minimum specifications for the entire voltage and temperature ranges.

Table 13. DC Chip-Level Specifications

Symbol	Description	Conditions	Min	Typ	Max	Units
V_{DD} [35, 36, 37, 38]	Supply voltage	No USB activity. Refer the table DC POR and LVD Specifications on page 25	1.71	–	5.50	V
V_{DDUSB} [35, 36, 37, 38]	Operating voltage	USB activity, USB regulator enabled	4.35	–	5.25	V
		USB activity, USB regulator bypassed	3.15	3.3	3.60	V
I_{DD24}	Supply current, IMO = 24 MHz	Conditions are $V_{DD} \leq 3.0$ V, $T_A = 25$ °C, CPU = 24 MHz. CapSense running at 12 MHz, no I/O sourcing current	–	2.88	4.00	mA
I_{DD12}	Supply current, IMO = 12 MHz	Conditions are $V_{DD} \leq 3.0$ V, $T_A = 25$ °C, CPU = 12 MHz. CapSense running at 12 MHz, no I/O sourcing current	–	1.71	2.60	mA
I_{DD6}	Supply current, IMO = 6 MHz	Conditions are $V_{DD} \leq 3.0$ V, $T_A = 25$ °C, CPU = 6 MHz. CapSense running at 6 MHz, no I/O sourcing current	–	1.16	1.80	mA
$I_{DDAVG10}$	Average supply current per sensor	One sensor scanned at 10 mS rate	–	250	–	μ A
$I_{DDAVG100}$	Average supply current per sensor	One sensor scanned at 100 mS rate	–	25	–	μ A
$I_{DDAVG500}$	Average supply current per sensor	One sensor scanned at 500 mS rate	–	7	–	μ A
I_{SB0}	Deep sleep current	$V_{DD} \leq 3.0$ V, $T_A = 25$ °C, I/O regulator turned off	–	0.10	1.05	μ A
I_{SB1}	Standby current with POR, LVD and sleep timer	$V_{DD} \leq 3.0$ V, $T_A = 25$ °C, I/O regulator turned off	–	1.07	1.50	μ A
I_{SB12C}	Standby current with I ² C enabled	Conditions are $V_{DD} = 3.3$ V, $T_A = 25$ °C and CPU = 24 MHz	–	1.64	–	μ A

Notes

35. When V_{DD} remains in the range from 1.71 V to 1.9 V for more than 50 μ s, the slew rate when moving from the 1.71 V to 1.9 V range to greater than 2 V must be slower than 1 V/500 μ s to avoid triggering POR. The only other restriction on slew rates for any other voltage range or transition is the SR_{POWER_UP} parameter.
36. If powering down in standby sleep mode, to properly detect and recover from a V_{DD} brown out condition any of the following actions must be taken:
 - a. Bring the device out of sleep before powering down.
 - b. Assure that V_{DD} falls below 100 mV before powering back up.
 - c. Set the No Buzz bit in the OSC_CR0 register to keep the voltage monitoring circuit powered during sleep.
 - d. Increase the buzz rate to assure that the falling edge of V_{DD} is captured. The rate is configured through the PSSDC bits in the SLP_CFG register.
 For the referenced registers, refer to the *CY8C20X36 Technical Reference Manual*. In deep sleep mode, additional low power voltage monitoring circuitry allows V_{DD} brown out conditions to be detected for edge rates slower than 1V/ms.
37. For USB mode, the V_{DD} supply for bus-powered application should be limited to 4.35 V–5.35 V. For self-powered application, V_{DD} should be 3.15 V–3.45 V.
38. For proper CapSense block functionality, if the drop in V_{DD} exceeds 5% of the base V_{DD} , the rate at which V_{DD} drops should not exceed 200 mV/s. Base V_{DD} can be between 1.8 V and 5.5 V

DC GPIO Specifications

The following tables list guaranteed maximum and minimum specifications for the voltage and temperature ranges: 3.0 V to 5.5 V and $-40\text{ }^{\circ}\text{C} \leq T_A \leq 85\text{ }^{\circ}\text{C}$, 2.4 V to 3.0 V and $-40\text{ }^{\circ}\text{C} \leq T_A \leq 85\text{ }^{\circ}\text{C}$, or 1.71 V to 2.4 V and $-40\text{ }^{\circ}\text{C} \leq T_A \leq 85\text{ }^{\circ}\text{C}$, respectively. Typical parameters apply to 5 V and 3.3 V at 25 C and are for design guidance only.

Table 14. 3.0 V to 5.5 V DC GPIO Specifications

Symbol	Description	Conditions	Min	Typ	Max	Units
R _{PU}	Pull-up resistor	–	4	5.60	8	kΩ
V _{OH1}	High output voltage Port 2 or 3 or 4 pins	I _{OH} ≤ 10 μA, maximum of 10 mA source current in all I/Os	V _{DD} – 0.20	–	–	V
V _{OH2}	High output voltage Port 2 or 3 or 4 pins	I _{OH} = 1 mA, maximum of 20 mA source current in all I/Os	V _{DD} – 0.90	–	–	V
V _{OH3}	High output voltage Port 0 or 1 pins with LDO regulator Disabled for port 1	I _{OH} < 10 μA, maximum of 10 mA source current in all I/Os	V _{DD} – 0.20	–	–	V
V _{OH4}	High output voltage Port 0 or 1 pins with LDO regulator Disabled for port 1	I _{OH} = 5 mA, maximum of 20 mA source current in all I/Os	V _{DD} – 0.90	–	–	V
V _{OH5}	High output voltage Port 1 Pins with LDO Regulator Enabled for 3 V out	I _{OH} < 10 μA, V _{DD} > 3.1 V, maximum of 4 I/Os all sourcing 5 mA	2.85	3.00	3.30	V
V _{OH6}	High output voltage Port 1 pins with LDO regulator enabled for 3 V out	I _{OH} = 5 mA, V _{DD} > 3.1 V, maximum of 20 mA source current in all I/Os	2.20	–	–	V
V _{OH7}	High output voltage Port 1 pins with LDO enabled for 2.5 V out	I _{OH} < 10 μA, V _{DD} > 2.7 V, maximum of 20 mA source current in all I/Os	2.35	2.50	2.75	V
V _{OH8}	High output voltage Port 1 pins with LDO enabled for 2.5 V out	I _{OH} = 2 mA, V _{DD} > 2.7 V, maximum of 20 mA source current in all I/Os	1.90	–	–	V
V _{OH9}	High output voltage Port 1 pins with LDO enabled for 1.8 V out	I _{OH} < 10 μA, V _{DD} > 2.7 V, maximum of 20 mA source current in all I/Os	1.60	1.80	2.10	V
V _{OH10}	High output voltage Port 1 pins with LDO enabled for 1.8 V out	I _{OH} = 1 mA, V _{DD} > 2.7 V, maximum of 20 mA source current in all I/Os	1.20	–	–	V
V _{OL}	Low output voltage	I _{OL} = 25 mA, V _{DD} > 3.3 V, maximum of 60 mA sink current on even port pins (for example, P0[2] and P1[4]) and 60 mA sink current on odd port pins (for example, P0[3] and P1[5])	–	–	0.75	V
V _{IL}	Input low voltage	–	–	–	0.80	V
V _{IH}	Input high voltage	–	2.00	–	–	V
V _H	Input hysteresis voltage	–	–	80	–	mV
I _{IL}	Input leakage (Absolute Value)	–	–	0.001	1	μA
C _{PIN}	Pin capacitance	Package and pin dependent Temp = 25 °C	0.50	1.70	7	pF
V _{ILLVT3.3}	Input Low Voltage with low threshold enable set, Enable for Port1	Bit3 of IO_CFG1 set to enable low threshold voltage of Port1 input	0.8	V	–	–
V _{IHLVT3.3}	Input High Voltage with low threshold enable set, Enable for Port1	Bit3 of IO_CFG1 set to enable low threshold voltage of Port1 input	1.4	–	–	V
V _{ILLVT5.5}	Input Low Voltage with low threshold enable set, Enable for Port1	Bit3 of IO_CFG1 set to enable low threshold voltage of Port1 input	0.8	V	–	–
V _{IHLVT5.5}	Input High Voltage with low threshold enable set, Enable for Port1	Bit3 of IO_CFG1 set to enable low threshold voltage of Port1 input	1.7	–	–	V

Table 15. 2.4 V to 3.0 V DC GPIO Specifications

Symbol	Description	Conditions	Min	Typ	Max	Units
R _{PU}	Pull-up resistor	–	4	5.60	8	kΩ
V _{OH1}	High output voltage Port 2 or 3 or 4 pins	I _{OH} < 10 μA, maximum of 10 mA source current in all I/Os	V _{DD} – 0.20	–	–	V
V _{OH2}	High output voltage Port 2 or 3 or 4 pins	I _{OH} = 0.2 mA, maximum of 10 mA source current in all I/Os	V _{DD} – 0.40	–	–	V
V _{OH3}	High output voltage Port 0 or 1 pins with LDO regulator Disabled for port 1	I _{OH} < 10 μA, maximum of 10 mA source current in all I/Os	V _{DD} – 0.20	–	–	V
V _{OH4}	High output voltage Port 0 or 1 pins with LDO regulator Disabled for Port 1	I _{OH} = 2 mA, maximum of 10 mA source current in all I/Os	V _{DD} – 0.50	–	–	V
V _{OH5A}	High output voltage Port 1 pins with LDO enabled for 1.8 V out	I _{OH} < 10 μA, V _{DD} > 2.4 V, maximum of 20 mA source current in all I/Os	1.50	1.80	2.10	V
V _{OH6A}	High output voltage Port 1 pins with LDO enabled for 1.8 V out	I _{OH} = 1 mA, V _{DD} > 2.4 V, maximum of 20 mA source current in all I/Os	1.20	–	–	V
V _{OL}	Low output voltage	I _{OL} = 10 mA, maximum of 30 mA sink current on even port pins (for example, P0[2] and P1[4]) and 30 mA sink current on odd port pins (for example, P0[3] and P1[5])	–	–	0.75	V
V _{IL}	Input low voltage	–	–	–	0.72	V
V _{IH}	Input high voltage	–	1.40	–	–	V
V _H	Input hysteresis voltage	–	–	80	–	mV
I _{IL}	Input leakage (absolute value)	–	–	1	1000	nA
C _{PIN}	Capacitive load on pins	Package and pin dependent Temp = 25 °C	0.50	1.70	7	pF
V _{ILLVT2.5}	Input Low Voltage with low threshold enable set, Enable for Port1	Bit3 of IO_CFG1 set to enable low threshold voltage of Port1 input	0.7	V	–	
V _{IHLVT2.5}	Input High Voltage with low threshold enable set, Enable for Port1	Bit3 of IO_CFG1 set to enable low threshold voltage of Port1 input	1.2	–	–	V

Table 16. 1.71 V to 2.4 V DC GPIO Specifications

Symbol	Description	Conditions	Min	Typ	Max	Units
R _{PU}	Pull-up resistor	–	4	5.60	8	kΩ
V _{OH1}	High output voltage Port 2 or 3 or 4 pins	I _{OH} = 10 μA, maximum of 10 mA source current in all I/Os	V _{DD} – 0.20	–	–	V
V _{OH2}	High output voltage Port 2 or 3 or 4 pins	I _{OH} = 0.5 mA, maximum of 10 mA source current in all I/Os	V _{DD} – 0.50	–	–	V
V _{OH3}	High output voltage Port 0 or 1 pins with LDO regulator Disabled for Port 1	I _{OH} = 100 μA, maximum of 10 mA source current in all I/Os	V _{DD} – 0.20	–	–	V
V _{OH4}	High output voltage Port 0 or 1 Pins with LDO Regulator Disabled for Port 1	I _{OH} = 2 mA, maximum of 10 mA source current in all I/Os	V _{DD} – 0.50	–	–	V
V _{OL}	Low output voltage	I _{OL} = 5 mA, maximum of 20 mA sink current on even port pins (for example, P0[2] and P1[4]) and 30 mA sink current on odd port pins (for example, P0[3] and P1[5])	–	–	0.40	V

Table 16. 1.71 V to 2.4 V DC GPIO Specifications (continued)

Symbol	Description	Conditions	Min	Typ	Max	Units
V _{IL}	Input low voltage	–	–	–	0.30 × V _{DD}	V
V _{IH}	Input high voltage	–	0.65 × V _{DD}	–	–	V
V _H	Input hysteresis voltage	–	–	80	–	mV
I _{IL}	Input leakage (absolute value)	–	–	1	1000	nA
C _{PIN}	Capacitive load on pins	Package and pin dependent temp = 25 °C	0.50	1.70	7	pF

Table 17. DC Characteristics – USB Interface

Symbol	Description	Conditions	Min	Typ	Max	Units
R _{USBI}	USB D+ pull-up resistance	With idle bus	900	–	1575	Ω
R _{USBA}	USB D+ pull-up resistance	While receiving traffic	1425	–	3090	Ω
V _{OHUSB}	Static output high	–	2.8	–	3.6	V
V _{OLUSB}	Static output low	–	–	–	0.3	V
V _{DI}	Differential input sensitivity	–	0.2	–	–	V
V _{CM}	Differential input common mode range	–	0.8	–	2.5	V
V _{SE}	Single ended receiver threshold	–	0.8	–	2.0	V
C _{IN}	Transceiver capacitance	–	–	–	50	pF
I _{IO}	High Z state data line leakage	On D+ or D- line	–10	–	+10	μA
R _{PS2}	PS/2 pull-up resistance	–	3000	5000	7000	Ω
R _{EXT}	External USB series resistor	In series with each USB pin	21.78	22.0	22.22	Ω

DC Analog Mux Bus Specifications

The following table lists guaranteed maximum and minimum specifications for the entire voltage and temperature ranges.

Table 18. DC Analog Mux Bus Specifications

Symbol	Description	Conditions	Min	Typ	Max	Units
R _{SW}	Switch resistance to common analog bus	–	–	–	800	Ω
R _{GND}	Resistance of initialization switch to V _{SS}	–	–	–	800	Ω

The maximum pin voltage for measuring R_{SW} and R_{GND} is 1.8 V

DC Low Power Comparator Specifications

The following table lists guaranteed maximum and minimum specifications for the entire voltage and temperature ranges.

Table 19. DC Comparator Specifications

Symbol	Description	Conditions	Min	Typ	Max	Units
V _{LPC}	Low power comparator (LPC) common mode	Maximum voltage limited to V _{DD}	0.0	–	1.8	V
I _{LPC}	LPC supply current	–	–	10	40	μA
V _{OSLPC}	LPC voltage offset	–	–	3	30	mV

Comparator User Module Electrical Specifications

The following table lists the guaranteed maximum and minimum specifications. Unless stated otherwise, the specifications are for the entire device voltage and temperature operating range: $-40\text{ }^{\circ}\text{C} \leq T_A \leq 85\text{ }^{\circ}\text{C}$, $1.71\text{ V} \leq V_{DD} \leq 5.5\text{ V}$.

Table 20. Comparator User Module Electrical Specifications

Symbol	Description	Conditions	Min	Typ	Max	Units
t_{COMP}	Comparator response time	50 mV overdrive	–	70	100	ns
Offset		Valid from 0.2 V to $V_{DD} - 0.2\text{ V}$	–	2.5	30	mV
Current		Average DC current, 50 mV overdrive	–	20	80	μA
PSRR	Supply voltage > 2 V	Power supply rejection ratio	–	80	–	dB
	Supply voltage < 2 V	Power supply rejection ratio	–	40	–	dB
Input range		–	0		1.5	V

ADC Electrical Specifications
Table 21. ADC User Module Electrical Specifications

Symbol	Description	Conditions	Min	Typ	Max	Units
Input						
V_{IN}	Input voltage range	–	0	–	V_{REFADC}	V
C_{IIN}	Input capacitance	–	–	–	5	pF
R_{IN}	Input resistance	Equivalent switched cap input resistance for 8-, 9-, or 10-bit resolution	$1/(500\text{fF} \times \text{data clock})$	$1/(400\text{fF} \times \text{data clock})$	$1/(300\text{fF} \times \text{data clock})$	Ω
Reference						
V_{REFADC}	ADC reference voltage	–	1.14	–	1.26	V
Conversion Rate						
F_{CLK}	Data clock	Source is chip's internal main oscillator. See AC Chip-Level Specifications for accuracy	2.25	–	6	MHz
S8	8-bit sample rate	Data clock set to 6 MHz. sample rate = $0.001 / (2^{\text{Resolution}} / \text{Data Clock})$	–	23.43	–	ksps
S10	10-bit sample rate	Data clock set to 6 MHz. sample rate = $0.001 / (2^{\text{resolution}} / \text{data clock})$	–	5.85	–	ksps
DC Accuracy						
RES	Resolution	Can be set to 8-, 9-, or 10-bit	8	–	10	bits
DNL	Differential nonlinearity	–	–1	–	+2	LSB
INL	Integral nonlinearity	–	–2	–	+2	LSB
E_{OFFSET}	Offset error	8-bit resolution	0	3.20	19.20	LSB
		10-bit resolution	0	12.80	76.80	LSB
E_{GAIN}	Gain error	For any resolution	–5	–	+5	%FSR
Power						
I_{ADC}	Operating current	–	–	2.10	2.60	mA
PSRR	Power supply rejection ratio	PSRR ($V_{DD} > 3.0\text{ V}$)	–	24	–	dB
		PSRR ($V_{DD} < 3.0\text{ V}$)	–	30	–	dB

DC POR and LVD Specifications

The following table lists guaranteed maximum and minimum specifications for the entire voltage and temperature ranges.

Table 22. DC POR and LVD Specifications

Symbol	Description	Conditions	Min	Typ	Max	Units
V _{POR0}	1.66 V selected in PSoC Designer	V _{DD} must be greater than or equal to 1.71 V during startup, reset from the XRES pin, or reset from watchdog.	1.61	1.66	1.71	V
V _{POR1}	2.36 V selected in PSoC Designer		–	2.36	2.41	
V _{POR2}	2.60 V selected in PSoC Designer		–	2.60	2.66	
V _{POR3}	2.82 V selected in PSoC Designer		–	2.82	2.95	
V _{LVD0}	2.45 V selected in PSoC Designer	–	2.40	2.45	2.51	V
V _{LVD1}	2.71 V selected in PSoC Designer		2.64 ^[39]	2.71	2.78	
V _{LVD2}	2.92 V selected in PSoC Designer		2.85 ^[40]	2.92	2.99	
V _{LVD3}	3.02 V selected in PSoC Designer		2.95 ^[41]	3.02	3.09	
V _{LVD4}	3.13 V selected in PSoC Designer		3.06	3.13	3.20	
V _{LVD5}	1.90 V selected in PSoC Designer		1.84	1.90	2.32	
V _{LVD6}	1.80 V selected in PSoC Designer		1.75 ^[42]	1.80	1.84	
V _{LVD7}	4.73 V selected in PSoC Designer		4.62	4.73	4.83	

DC Programming Specifications

The following table lists guaranteed maximum and minimum specifications for the entire voltage and temperature ranges.

Table 23. DC Programming Specifications

Symbol	Description	Conditions	Min	Typ	Max	Units
V _{DDIWRITE}	Supply voltage for flash write operations	–	1.71	–	5.25	V
I _{DDP}	Supply current during programming or verify	–	–	5	25	mA
V _{ILP}	Input low voltage during programming or verify	See the appropriate DC GPIO Specifications on page 21	–	–	V _{IL}	V
V _{IHP}	Input high voltage during programming or verify	See the appropriate DC GPIO Specifications on page 21	V _{IH}	–	–	V
I _{ILP}	Input current when Applying V _{ILP} to P1[0] or P1[1] during programming or verify	Driving internal pull-down resistor	–	–	0.2	mA
I _{IHP}	Input current when applying V _{IHP} to P1[0] or P1[1] during programming or verify	Driving internal pull-down resistor	–	–	1.5	mA
V _{OLP}	Output low voltage during programming or verify		–	–	V _{SS} + 0.75	V
V _{OHP}	Output high voltage during programming or verify	See appropriate DC GPIO Specifications on page 21 . For V _{DD} > 3 V use V _{OH4} in Table 12 on page 19 .	V _{OH}	–	V _{DD}	V
Flash _{ENPB}	Flash write endurance	Erase/write cycles per block	50,000	–	–	–
Flash _{DR}	Flash data retention	Following maximum Flash write cycles; ambient temperature of 55 °C	20	–	–	Years

Notes

- 39. Always greater than 50 mV above V_{PPOR1} voltage for falling supply.
- 40. Always greater than 50 mV above V_{PPOR2} voltage for falling supply.
- 41. Always greater than 50 mV above V_{PPOR3} voltage for falling supply.
- 42. Always greater than 50 mV above V_{PPOR0} voltage for falling supply.

DC I²C Specifications

The following tables list guaranteed maximum and minimum specifications for the voltage and temperature ranges: 3.0 V to 5.5 V and $-40\text{ }^{\circ}\text{C} \leq T_A \leq 85\text{ }^{\circ}\text{C}$, 2.4 V to 3.0 V and $-40\text{ }^{\circ}\text{C} \leq T_A \leq 85\text{ }^{\circ}\text{C}$, or 1.71 V to 2.4 V and $-40\text{ }^{\circ}\text{C} \leq T_A \leq 85\text{ }^{\circ}\text{C}$, respectively. Typical parameters apply to 5 V and 3.3 V at 25 °C and are for design guidance only.

Table 24. DC I²C Specifications

Symbol	Description	Conditions	Min	Typ	Max	Units
V _{ILi2C}	Input low level	$3.1\text{ V} \leq V_{DD} \leq 5.5\text{ V}$	–	–	$0.25 \times V_{DD}$	V
		$2.5\text{ V} \leq V_{DD} \leq 3.0\text{ V}$	–	–	$0.3 \times V_{DD}$	V
		$1.71\text{ V} \leq V_{DD} \leq 2.4\text{ V}$	–	–	$0.3 \times V_{DD}$	V
V _{IHi2C}	Input high level	$1.71\text{ V} \leq V_{DD} \leq 5.5\text{ V}$	$0.65 \times V_{DD}$	–	–	V

DC Reference Buffer Specifications

The following tables list guaranteed maximum and minimum specifications for the voltage and temperature ranges: 3.0 V to 5.5 V and $-40\text{ }^{\circ}\text{C} \leq T_A \leq 85\text{ }^{\circ}\text{C}$, 2.4 V to 3.0 V and $-40\text{ }^{\circ}\text{C} \leq T_A \leq 85\text{ }^{\circ}\text{C}$, or 1.71 V to 2.4 V and $-40\text{ }^{\circ}\text{C} \leq T_A \leq 85\text{ }^{\circ}\text{C}$, respectively. Typical parameters apply to 5 V and 3.3 V at 25 °C and are for design guidance only.

Table 25. DC Reference Buffer Specifications

Symbol	Description	Conditions	Min	Typ	Max	Units
V _{Ref}	Reference buffer output	$1.7\text{ V} \leq V_{DD} \leq 5.5\text{ V}$	1	–	1.05	V
V _{RefHi}	Reference buffer output	$1.7\text{ V} \leq V_{DD} \leq 5.5\text{ V}$	1.2	–	1.25	V

DC IDAC Specifications

The following table lists guaranteed maximum and minimum specifications for the entire voltage and temperature ranges.

Table 26. DC IDAC Specifications

Symbol	Description	Min	Typ	Max	Units	Notes
IDAC_DNL	Differential nonlinearity	–4.5	–	+4.5	LSB	
IDAC_INL	Integral nonlinearity	–5	–	+5	LSB	
IDAC_Gain (Source)	Range = 0.5x	6.64	–	22.46	μA	DAC setting = 128 dec. Not recommended for CapSense applications.
	Range = 1x	14.5	–	47.8	μA	
	Range = 2x	42.7	–	92.3	μA	
	Range = 4x	91.1	–	170	μA	DAC setting = 128 dec
	Range = 8x	184.5	–	426.9	μA	DAC setting = 128 dec

AC Chip-Level Specifications

The following table lists guaranteed maximum and minimum specifications for the entire voltage and temperature ranges.

Table 27. AC Chip-Level Specifications

Symbol	Description	Conditions	Min	Typ	Max	Units
F _{IMO24}	IMO frequency at 24 MHz Setting	–	22.8	24	25.2	MHz
F _{IMO12}	IMO frequency at 12 MHz setting	–	11.4	12	12.6	MHz
F _{IMO6}	IMO frequency at 6 MHz setting	–	5.7	6.0	6.3	MHz
F _{CPU}	CPU frequency	–	0.75	–	25.20	MHz
F _{32K1}	ILO frequency	–	19	32	50	kHz
F _{32K_U}	ILO untrimmed frequency	–	13	32	82	kHz
DC _{IMO}	Duty cycle of IMO	–	40	50	60	%
DC _{ILO}	ILO duty cycle	–	40	50	60	%
SR _{POWER_UP}	Power supply slew rate	V _{DD} slew rate during power-up	–	–	250	V/ms
t _{XRST}	External reset pulse width at power-up	After supply voltage is valid	1	–	–	ms
t _{XRST2}	External reset pulse width after power-up ^[43]	Applies after part has booted	10	–	–	μs
t _{OS}	Startup time of ECO	–	–	1	–	s
t _{JIT_IMO} ^[44]	N=32	6 MHz IMO cycle-to-cycle jitter (RMS)	–	0.7	6.7	ns
		6 MHz IMO long term N (N = 32) cycle-to-cycle jitter (RMS)	–	4.3	29.3	ns
		6 MHz IMO period jitter (RMS)	–	0.7	3.3	ns
		12 MHz IMO cycle-to-cycle jitter (RMS)	–	0.5	5.2	ns
		12 MHz IMO long term N (N = 32) cycle-to-cycle jitter (RMS)	–	2.3	5.6	ns
		12 MHz IMO period jitter (RMS)	–	0.4	2.6	ns
		24 MHz IMO cycle-to-cycle jitter (RMS)	–	1.0	8.7	ns
		24 MHz IMO long term N (N = 32) cycle-to-cycle jitter (RMS)	–	1.4	6.0	ns
		24 MHz IMO period jitter (RMS)	–	0.6	4.0	ns

Notes

43. The minimum required XRES pulse length is longer when programming the device (see Table 33 on page 30).

44. Refer to Cypress Jitter Specifications application note, [Understanding Datasheet Jitter Specifications for Cypress Timing Products – AN5054](#) for more information.

AC GPIO Specifications

The following table lists guaranteed maximum and minimum specifications for the entire voltage and temperature ranges.

Table 28. AC GPIO Specifications

Symbol	Description	Conditions	Min	Typ	Max	Units
F_{GPIO}	GPIO operating frequency	Normal strong mode Port 0, 1	0	–	6 MHz for $1.71\text{ V} < V_{DD} < 2.40\text{ V}$ 12 MHz for $2.40\text{ V} < V_{DD} < 5.50\text{ V}$	MHz MHz
t_{RISE23}	Rise time, strong mode, Cload = 50 pF Port 2 or 3 or 4 pins	$V_{DD} = 3.0\text{ to }3.6\text{ V}$, 10% to 90%	15	–	80	ns
$t_{RISE23L}$	Rise time, strong mode low supply, Cload = 50 pF, Port 2 or 3 or 4 pins	$V_{DD} = 1.71\text{ to }3.0\text{ V}$, 10% to 90%	15	–	80	ns
t_{RISE01}	Rise time, strong mode, Cload = 50 pF Ports 0 or 1	$V_{DD} = 3.0\text{ to }3.6\text{ V}$, 10% to 90% LDO enabled or disabled	10	–	50	ns
$t_{RISE01L}$	Rise time, strong mode low supply, Cload = 50 pF, Ports 0 or 1	$V_{DD} = 1.71\text{ to }3.0\text{ V}$, 10% to 90% LDO enabled or disabled	10	–	80	ns
t_{FALL}	Fall time, strong mode, Cload = 50 pF all ports	$V_{DD} = 3.0\text{ to }3.6\text{ V}$, 10% to 90%	10	–	50	ns
t_{FALLL}	Fall time, strong mode low supply, Cload = 50 pF, all ports	$V_{DD} = 1.71\text{ to }3.0\text{ V}$, 10% to 90%	10	–	70	ns

Figure 13. GPIO Timing Diagram

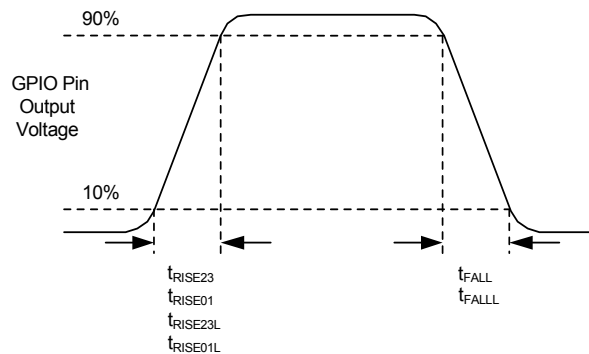

Table 29. AC Characteristics – USB Data Timings

Symbol	Description	Conditions	Min	Typ	Max	Units
t _{DRATE}	Full speed data rate	Average bit rate	12 – 0.25%	12	12 + 0.25%	MHz
t _{JR1}	Receiver jitter tolerance	To next transition	–18.5	–	18.5	ns
t _{JR2}	Receiver jitter tolerance	To pair transition	–9.0	–	9	ns
t _{DJ1}	FS Driver jitter	To next transition	–3.5	–	3.5	ns
t _{DJ2}	FS Driver jitter	To pair transition	–4.0	–	4.0	ns
t _{FDEOP}	Source jitter for differential transition	To SE0 transition	–2.0	–	5	ns
t _{FEOPT}	Source SE0 interval of EOP	–	160.0	–	175	ns
t _{FEOPR}	Receiver SE0 interval of EOP	–	82.0	–	–	ns
t _{FST}	Width of SE0 interval during differential transition	–	–	–	14	ns

Table 30. AC Characteristics – USB Driver

Symbol	Description	Conditions	Min	Typ	Max	Units
t _{FR}	Transition rise time	50 pF	4	–	20	ns
t _{FF}	Transition fall time	50 pF	4	–	20	ns
t _{FRFM} ^[45]	Rise/fall time matching	–	90	–	111	%
V _{CRS}	Output signal crossover voltage	–	1.30	–	2.00	V

AC Comparator Specifications

The following table lists guaranteed maximum and minimum specifications for the entire voltage and temperature ranges.

Table 31. AC Low Power Comparator Specifications

Symbol	Description	Conditions	Min	Typ	Max	Units
t _{LPC}	Comparator response time, 50 mV overdrive	50 mV overdrive does not include offset voltage.	–	–	100	ns

AC External Clock Specifications

The following table lists guaranteed maximum and minimum specifications for the entire voltage and temperature ranges.

Table 32. AC External Clock Specifications

Symbol	Description	Conditions	Min	Typ	Max	Units
F _{OSCEXT}	Frequency (external oscillator frequency)	–	0.75	–	25.20	MHz
	High period	–	20.60	–	5300	ns
	Low period	–	20.60	–	–	ns
	Power-up IMO to switch	–	150	–	–	μs

Note

45. T_{FRFM} is not met under all conditions. There is a corner case at lower supply voltages, such as those under 3.3 V. This condition does not affect USB communications. Signal integrity tests show an excellent eye diagram at 3.15 V.

AC Programming Specifications

Figure 14. AC Waveform

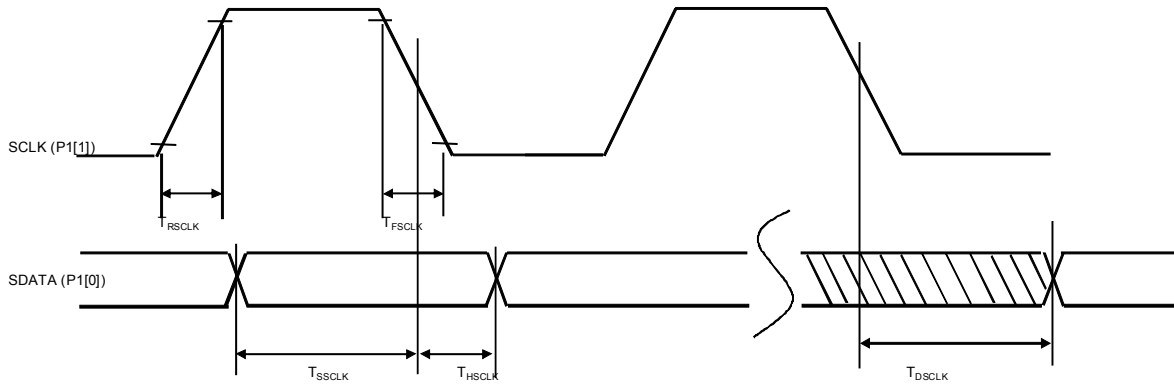

The following table lists the guaranteed maximum and minimum specifications for the entire voltage and temperature ranges.

Table 33. AC Programming Specifications

Symbol	Description	Conditions	Min	Typ	Max	Units
t_{RSCLK}	Rise time of SCLK	–	1	–	20	ns
t_{FSCLK}	Fall time of SCLK	–	1	–	20	ns
t_{SSCLK}	Data setup time to falling edge of SCLK	–	40	–	–	ns
t_{HSCLK}	Data hold time from falling edge of SCLK	–	40	–	–	ns
F_{SCLK}	Frequency of SCLK	–	0	–	8	MHz
t_{ERASEB}	Flash erase time (block)	–	–	–	18	ms
t_{WRITE}	Flash block write time	–	–	–	25	ms
t_{DSCLK}	Data out delay from falling edge of SCLK	$3.6 < V_{DD}$	–	–	60	ns
t_{DSCLK3}	Data out delay from falling edge of SCLK	$3.0 \leq V_{DD} \leq 3.6$	–	–	85	ns
t_{DSCLK2}	Data out delay from falling edge of SCLK	$1.71 \leq V_{DD} \leq 3.0$	–	–	130	ns
t_{XRST3}	External reset pulse width after power-up	Required to enter programming mode when coming out of sleep	300	–	–	μ s
t_{XRES}	XRES pulse length	–	300	–	–	μ s
$t_{VDDWAIT}^{[46]}$	V_{DD} stable to wait-and-poll hold off	–	0.1	–	1	ms
$t_{VDDXRES}^{[46]}$	V_{DD} stable to XRES assertion delay	–	14.27	–	–	ms
t_{POLL}	SDATA high pulse time	–	0.01	–	200	ms
$t_{ACQ}^{[46]}$	“Key window” time after a V_{DD} ramp acquire event, based on 256 ILO clocks.	–	3.20	–	19.60	ms
$t_{XRESINI}^{[46]}$	“Key window” time after an XRES event, based on 8 ILO clocks	–	98	–	615	μ s

Note

46. Valid from 5 to 50 °C. See the spec, CY8C20X66, CY8C20X46, CY8C20X36, CY7C643XX, CY7C604XX, CY8CTST2XX, CY8CTMG2XX, CY8C20X67, CY8C20X47, CY8C20X37, Programming Spec for more details.

AC I²C Specifications

The following table lists guaranteed maximum and minimum specifications for the entire voltage and temperature ranges.

Table 34. AC Characteristics of the I²C SDA and SCL Pins

Symbol	Description	Standard Mode		Fast Mode		Units
		Min	Max	Min	Max	
f _{SCL}	SCL clock frequency	0	100	0	400	kHz
t _{HD;STA}	Hold time (repeated) START condition. After this period, the first clock pulse is generated	4.0	–	0.6	–	µs
t _{LOW}	LOW period of the SCL clock	4.7	–	1.3	–	µs
t _{HIGH}	HIGH Period of the SCL clock	4.0	–	0.6	–	µs
t _{SU;STA}	Setup time for a repeated START condition	4.7	–	0.6	–	µs
t _{HD;DAT}	Data hold time	0	3.45	0	0.90	µs
t _{SU;DAT}	Data setup time	250	–	100 ^[47]	–	ns
t _{SU;STO}	Setup time for STOP condition	4.0	–	0.6	–	µs
t _{BUF}	Bus free time between a STOP and START condition	4.7	–	1.3	–	µs
t _{SP}	Pulse width of spikes are suppressed by the input filter	–	–	0	50	ns

Figure 15. Definition for Timing for Fast/Standard Mode on the I²C Bus

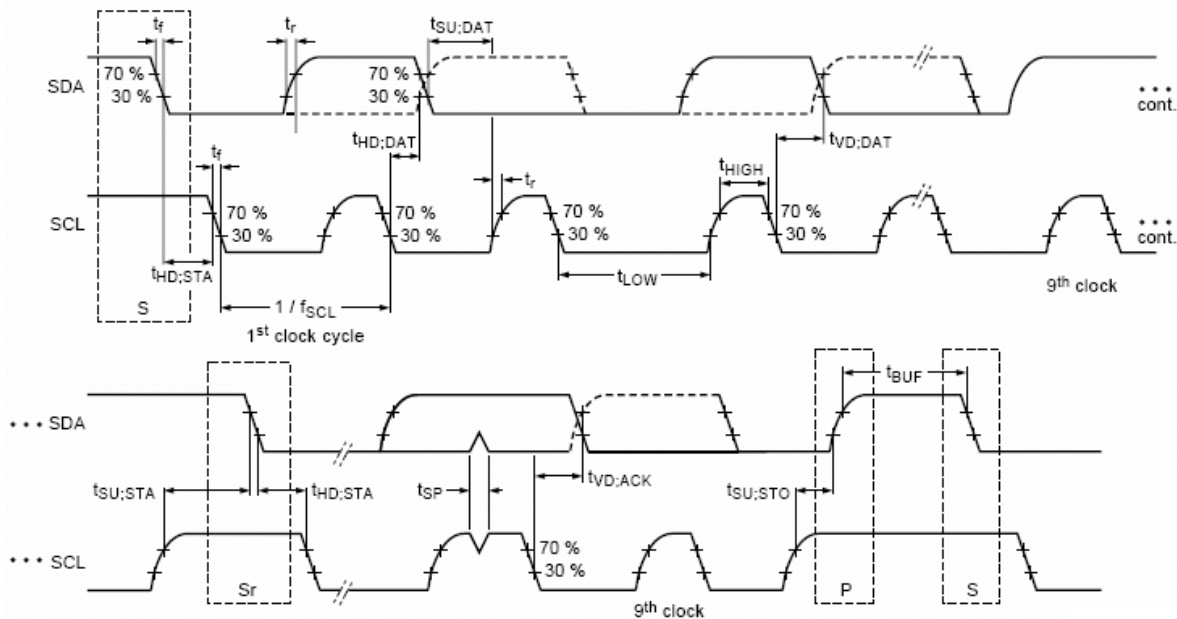

Note

47. A Fast-Mode I²C-bus device can be used in a standard mode I²C-bus system, but the requirement t_{SU;DAT} ≥ 250 ns must then be met. This automatically be the case if the device does not stretch the LOW period of the SCL signal. If such device does stretch the LOW period of the SCL signal, it must output the next data bit to the SDA line t_{rmax} + t_{SU;DAT} = 1000 + 250 = 1250 ns (according to the Standard-Mode I²C-bus specification) before the SCL line is released.

Table 35. SPI Master AC Specifications

Symbol	Description	Conditions	Min	Typ	Max	Units
F_{SCLK}	SCLK clock frequency	$V_{DD} \geq 2.4\text{ V}$ $V_{DD} < 2.4\text{ V}$	– –	– –	6 3	MHz MHz
DC	SCLK duty cycle	–	–	50	–	%
t_{SETUP}	MISO to SCLK setup time	$V_{DD} \geq 2.4\text{ V}$ $V_{DD} < 2.4\text{ V}$	60 100	– –	– –	ns ns
t_{HOLD}	SCLK to MISO hold time	–	40	–	–	ns
t_{OUT_VAL}	SCLK to MOSI valid time	–	–	–	40	ns
t_{OUT_H}	MOSI high time	–	40	–	–	ns

Figure 16. SPI Master Mode 0 and 2

SPI Master, modes 0 and 2

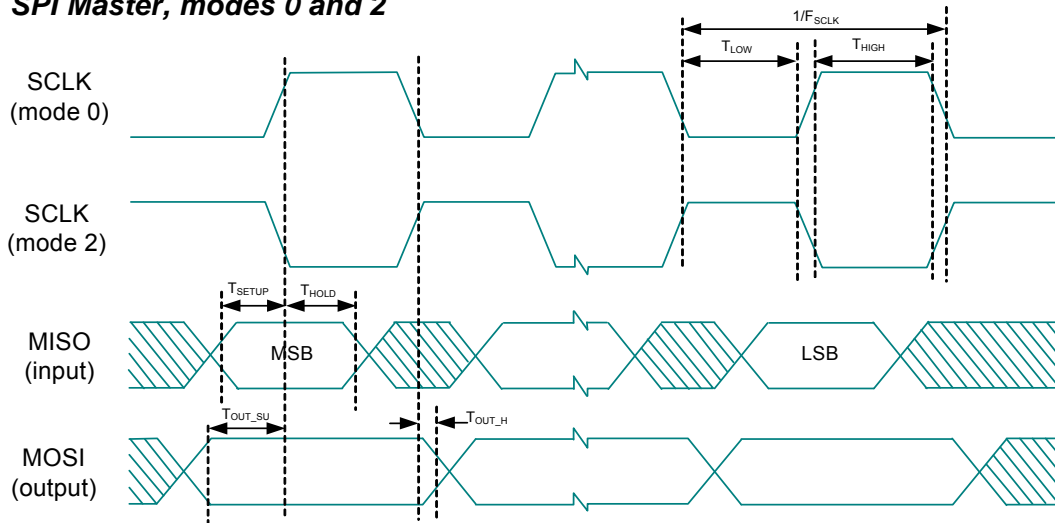

Figure 17. SPI Master Mode 1 and 3

SPI Master, modes 1 and 3

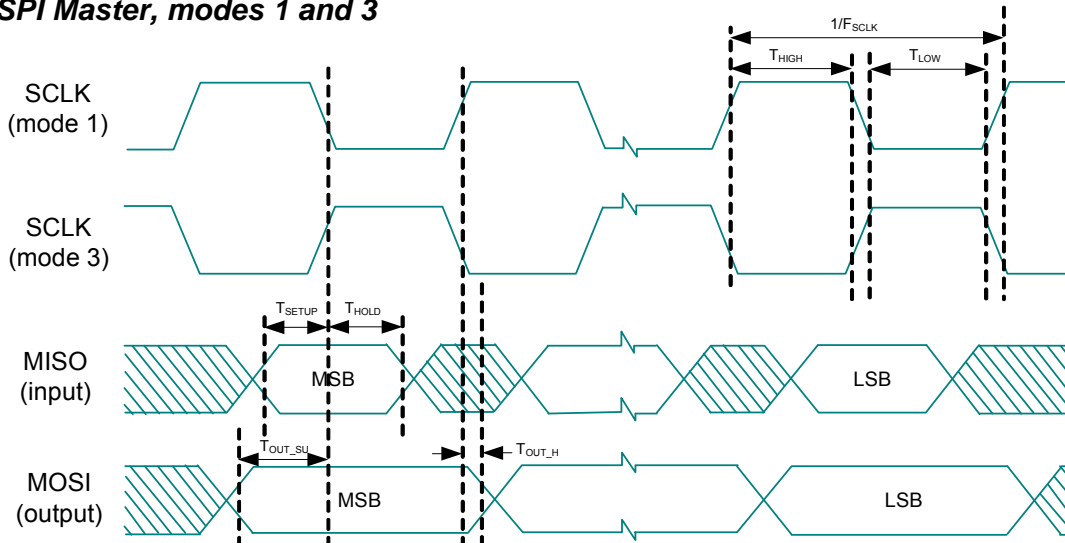

Table 36. SPI Slave AC Specifications

Symbol	Description	Conditions	Min	Typ	Max	Units
F_{SCLK}	SCLK clock frequency	–	–	–	4	MHz
t_{LOW}	SCLK low time	–	42	–	–	ns
t_{HIGH}	SCLK high time	–	42	–	–	ns
t_{SETUP}	MOSI to SCLK setup time	–	30	–	–	ns
t_{HOLD}	SCLK to MOSI hold time	–	50	–	–	ns
t_{SS_MISO}	SS high to MISO valid	–	–	–	153	ns
t_{SCLK_MISO}	SCLK to MISO valid	–	–	–	125	ns
t_{SS_HIGH}	SS high time	–	50	–	–	ns
t_{SS_CLK}	Time from SS low to first SCLK	–	2/SCLK	–	–	ns
t_{CLK_SS}	Time from last SCLK to SS high	–	2/SCLK	–	–	ns

Figure 18. SPI Slave Mode 0 and 2

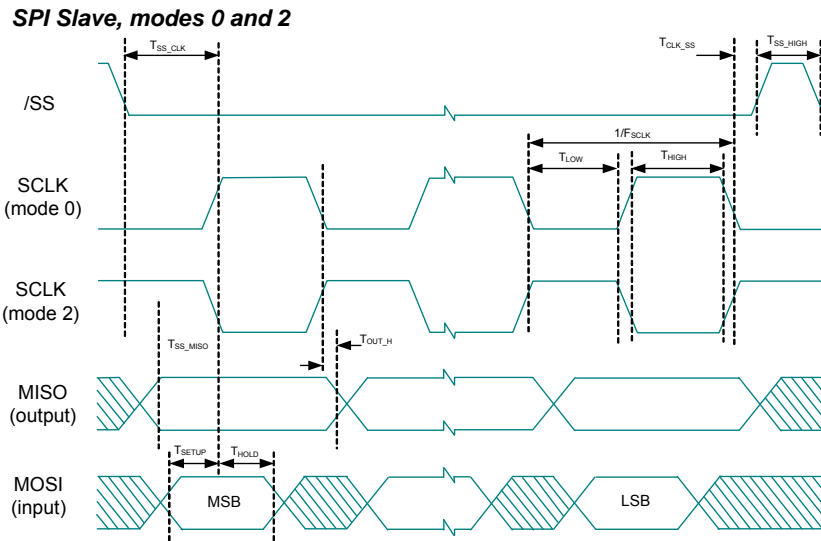
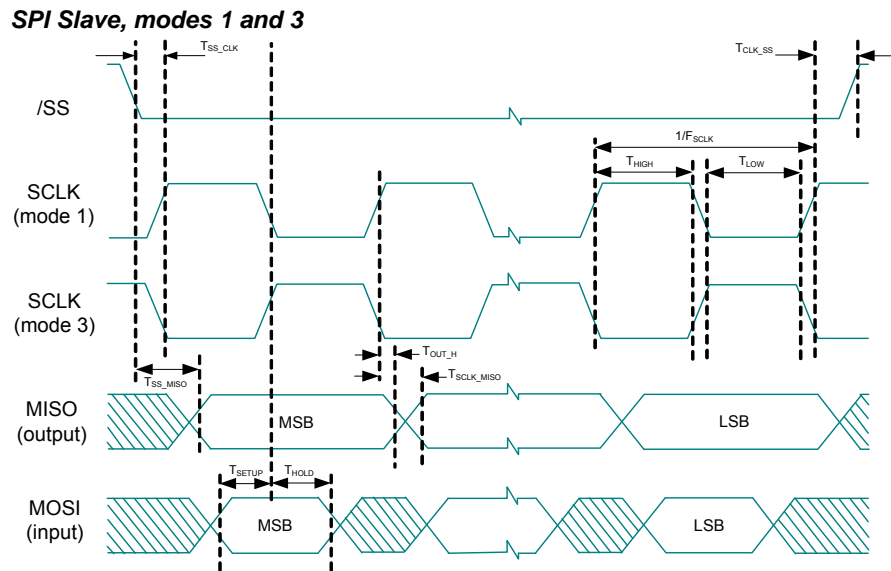

Figure 19. SPI Slave Mode 1 and 3



Packaging Information

This section illustrates the packaging specifications for the CY8C20X36A/46A/66A/96A/46AS/66AS PSoC device, along with the thermal impedances for each package.

Important Note Emulation tools may require a larger area on the target PCB than the chip's footprint. For a detailed description of the emulation tools' dimensions, refer to the document titled *PSoC Emulator Pod Dimensions* at <http://www.cypress.com/design/MR10161>.

Figure 20. 16-pin QFN (No E-Pad) (3 x 3 x 0.6 mm) LG16A (Sawn) Package Outline, 001-09116

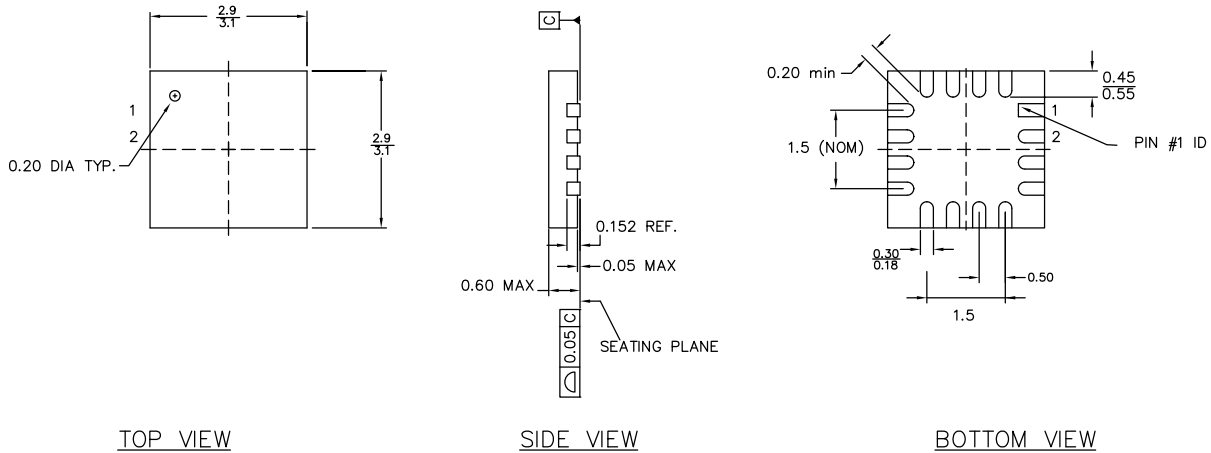

PART NO.	DESCRIPTION
LG16A	LEAD-FREE
LD16A	STANDARD

NOTES:

1. JEDEC # MO-220
2. Package Weight: 0.014g
3. DIMENSIONS IN MM, $\frac{\text{MIN}}{\text{MAX}}$

001-09116 *F

Figure 21. 24-pin QFN (4 x 4 x 0.55 mm) LQ24A 2.65 x 2.65 E-Pad (Sawn) Package Outline, 001-13937

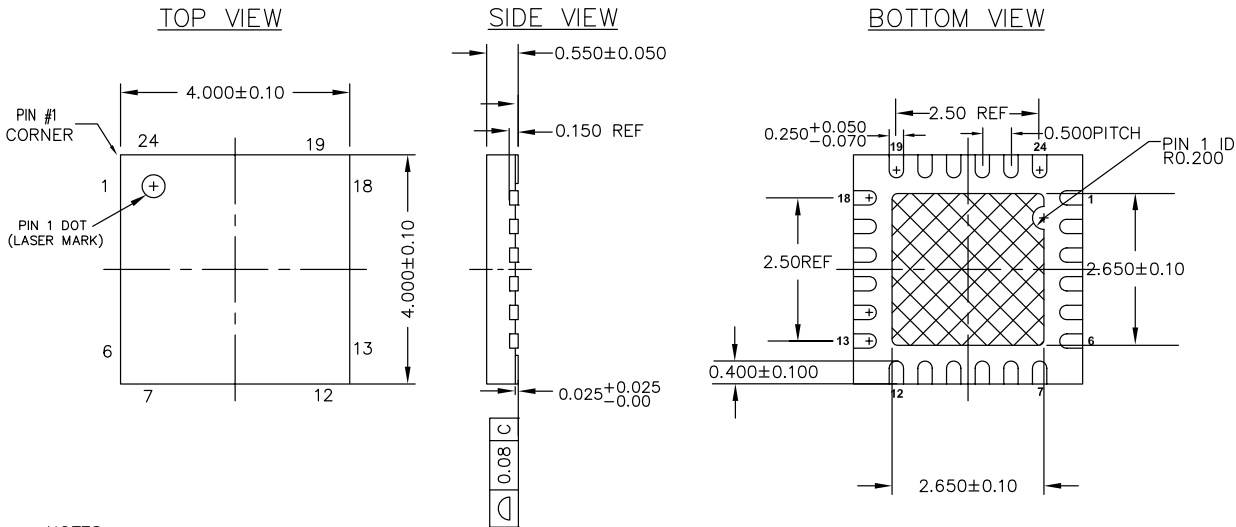

NOTES :

1.  HATCH IS SOLDERABLE EXPOSED METAL.
2. REFERENCE JEDEC # MO-248
3. UNIT PACKAGE WEIGHT : See Cypress Package Material Declaration Datasheet (PMDD) posted on the Cypress web
4. ALL DIMENSIONS ARE IN MILLIMETERS

001-13937 *D

Figure 22. 32-pin QFN (5 x 5 x 0.55 mm) LQ32 3.5 x 3.5 E-Pad (Sawn) Package Outline, 001-42168

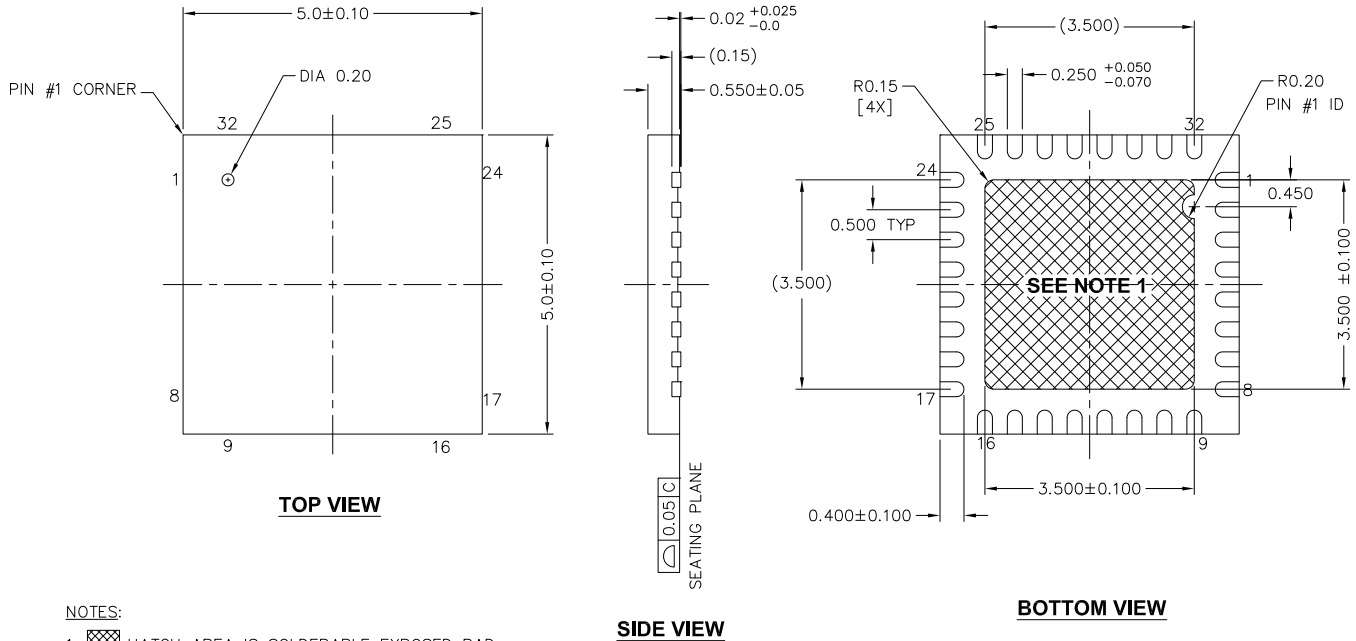

NOTES:

1.  HATCH AREA IS SOLDERABLE EXPOSED PAD
2. BASED ON REF JEDEC # MO-248
3. PACKAGE WEIGHT: 0.0388g
4. DIMENSIONS ARE IN MILLIMETERS

001-42168 *D

Figure 23. 48-pin SSOP (300 Mils) O483 Package Outline, 51-85061

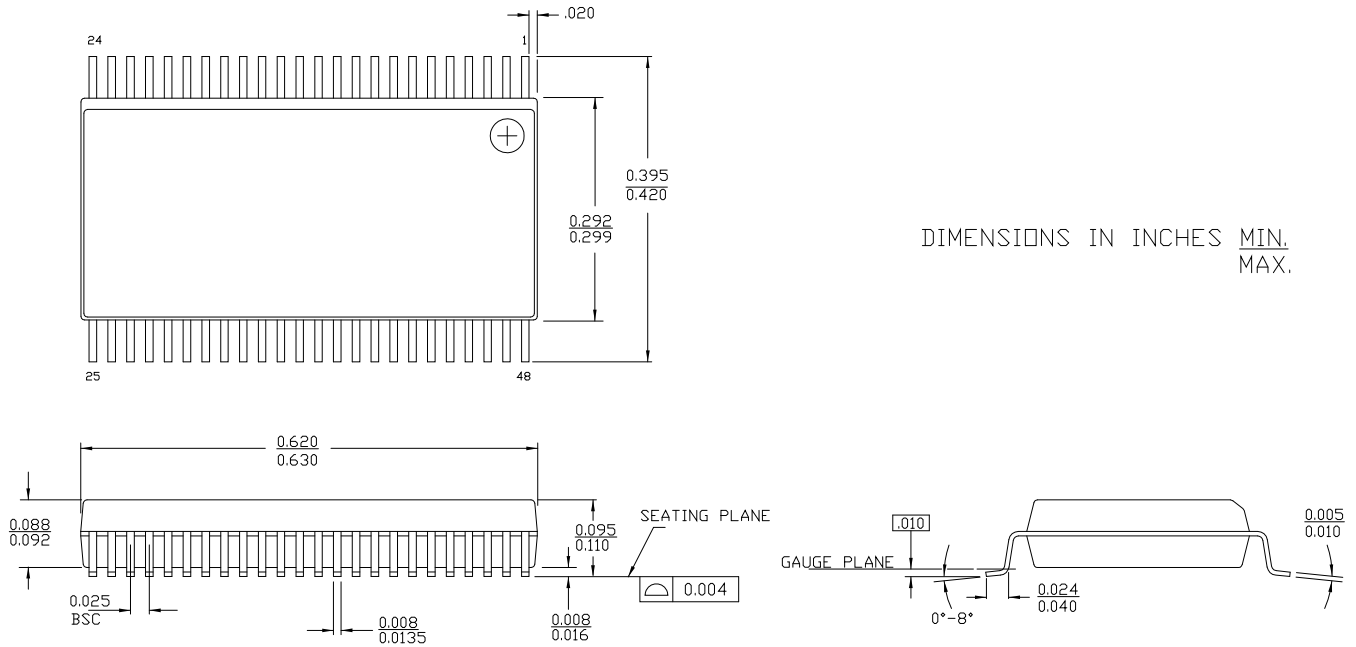

DIMENSIONS IN INCHES MIN. MAX.

51-85061 *E

Figure 24. 48-pin QFN (7 x 7 x 1.0 mm) LT48A 5.1 x 5.1 E-Pad (Sawn) Package Outline, 001-13191

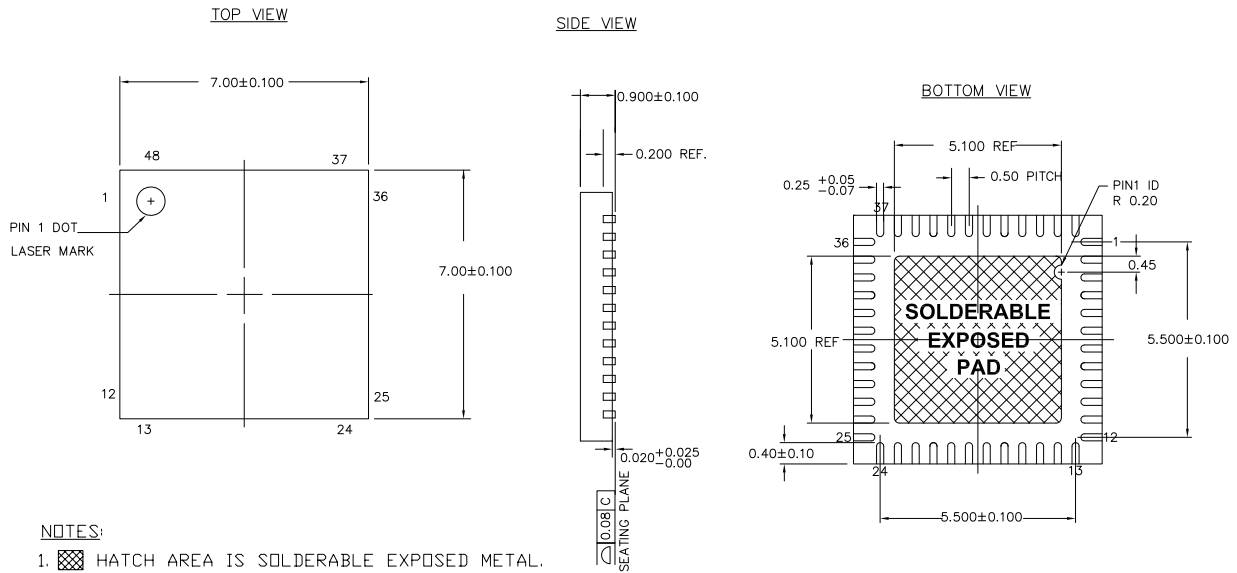

001-13191 *F

Figure 25. 48-pin QFN (6 x 6 x 0.6 mm) LQ48A 4.6 x 4.6 E-Pad (Sawn) Package Outline, 001-57280

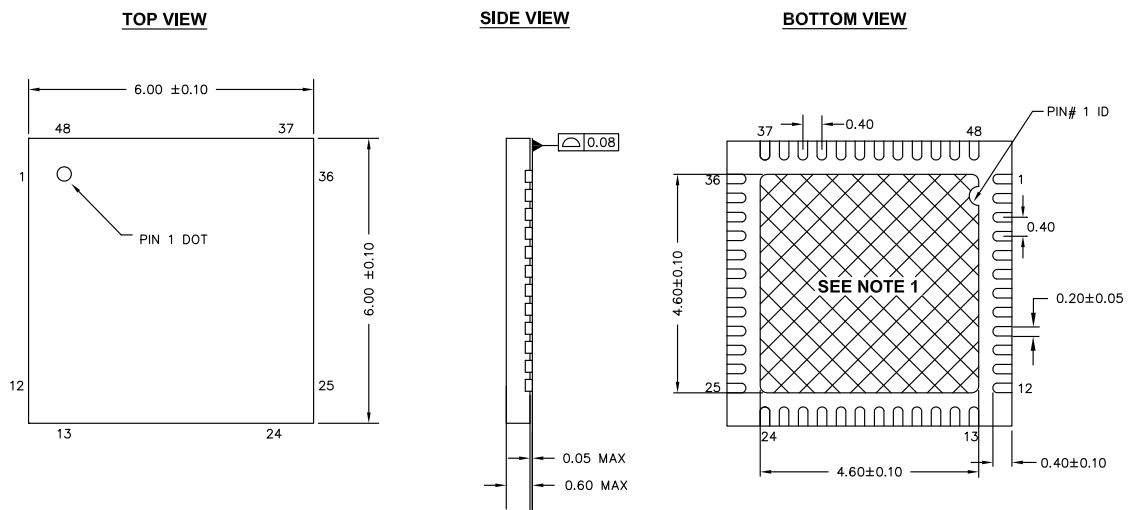

001-57280 *C

Important Notes

- For information on the preferred dimensions for mounting QFN packages, see the following Application Note at http://www.amkor.com/products/notes_papers/MLFAppNote.pdf.
- Pinned vias for thermal conduction are not required for the low power PSoC device.

Thermal Impedances
Table 37. Thermal Impedances per Package

Package	Typical θ_{JA} [48]	Typical θ_{JC}
16-pin QFN (No Center Pad)	33 °C/W	–
24-pin QFN [49]	21 °C/W	–
32-pin QFN [49]	20 °C/W	–
48-pin SSOP	69 °C/W	–
48-pin QFN (6 × 6 × 0.6 mm) [49]	25.20 °C/W	3.04 °C/W
48-pin QFN (7 × 7 × 1.0 mm) [49]	18 °C/W	–
30-ball WLCSP	54 °C/W	–

Capacitance on Crystal Pins
Table 38. Typical Package Capacitance on Crystal Pins

Package	Package Capacitance
32-pin QFN	3.2 pF
48-pin QFN	3.3 pF

Solder Reflow Specifications

Table 39 shows the solder reflow temperature limits that must not be exceeded.

Table 39. Solder Reflow Specifications

Package	Maximum Peak Temperature (T_C)	Maximum Time above $T_C - 5$ °C
16-pin QFN	260 °C	30 seconds
24-pin QFN	260 °C	30 seconds
32-pin QFN	260 °C	30 seconds
48-pin SSOP	260 °C	30 seconds
48-pin QFN (6 × 6 × 0.6 mm)	260 °C	30 seconds
48-pin QFN (7 × 7 × 1.0 mm)	260 °C	30 seconds
30-ball WLCSP	260 °C	30 seconds

Notes

48. $T_J = T_A + \text{Power} \times \theta_{JA}$.

49. To achieve the thermal impedance specified for the QFN package, the center thermal pad must be soldered to the PCB ground plane.

Development Tool Selection

Software

PSoC Designer™

At the core of the PSoC development software suite is PSoC Designer. Utilized by thousands of PSoC developers, this robust software has been facilitating PSoC designs for over half a decade. PSoC Designer is available free of charge at <http://www.cypress.com>.

PSoC Programmer

Flexible enough to be used on the bench in development, yet suitable for factory programming, PSoC Programmer works either as a standalone programming application or it can operate directly from PSoC Designer. PSoC Programmer software is compatible with both PSoC ICE-Cube In-Circuit Emulator and PSoC MiniProg. PSoC Programmer is available free of charge at <http://www.cypress.com>.

Development Kits

All development kits are sold at the Cypress Online Store.

CY3215-DK Basic Development Kit

The CY3215-DK is for prototyping and development with PSoC Designer. This kit supports in-circuit emulation and the software interface enables users to run, halt, and single step the processor and view the content of specific memory locations. PSoC Designer supports the advance emulation features also. The kit includes:

- PSoC Designer Software CD
- ICE-Cube In-Circuit Emulator
- ICE Flex-Pod for CY8C29X66A Family
- Cat-5 Adapter
- Mini-Eval Programming Board
- 110 ~ 240 V Power Supply, Euro-Plug Adapter
- iMAGEcraft C Compiler (Registration Required)
- ISSP Cable
- USB 2.0 Cable and Blue Cat-5 Cable
- 2 CY8C29466A-24PXI 28-PDIP Chip Samples

Evaluation Tools

All evaluation tools are sold at the Cypress Online Store.

CY3210-MiniProg1

The CY3210-MiniProg1 kit enables the user to program PSoC devices via the MiniProg1 programming unit. The MiniProg is a small, compact prototyping programmer that connects to the PC via a provided USB 2.0 cable. The kit includes:

- MiniProg Programming Unit
- MiniEval Socket Programming and Evaluation Board

- 28-pin CY8C29466A-24PXI PDIP PSoC Device Sample
- 28-pin CY8C27443A-24PXI PDIP PSoC Device Sample
- PSoC Designer Software CD
- Getting Started Guide
- USB 2.0 Cable

CY3210-PSoCEval1

The CY3210-PSoCEval1 kit features an evaluation board and the MiniProg1 programming unit. The evaluation board includes an LCD module, potentiometer, LEDs, and plenty of breadboarding space to meet all of your evaluation needs. The kit includes:

- Evaluation Board with LCD Module
- MiniProg Programming Unit
- 28-Pin CY8C29466A-24PXI PDIP PSoC Device Sample (2)
- PSoC Designer Software CD
- Getting Started Guide
- USB 2.0 Cable

CY3280-20X66 Universal CapSense Controller

The CY3280-20X66 CapSense Controller Kit is designed for easy prototyping and debug of CY8C20XX6A CapSense Family designs with pre-defined control circuitry and plug-in hardware. Programming hardware and an I2C-to-USB bridge are included for tuning and data acquisition.

The kit includes:

- CY3280-20X66 CapSense Controller Board
- CY3240-I2USB Bridge
- CY3210 MiniProg1 Programmer
- USB 2.0 Retractable Cable
- CY3280-20X66 Kit CD

Device Programmers

All device programmers are purchased from the Cypress Online Store.

CY3216 Modular Programmer

The CY3216 Modular Programmer kit features a modular programmer and the MiniProg1 programming unit. The modular programmer includes three programming module cards and supports multiple Cypress products. The kit includes:

- Modular Programmer Base
- Three Programming Module Cards
- MiniProg Programming Unit
- PSoC Designer Software CD
- Getting Started Guide
- USB 2.0 Cable

CY3207ISSP In-System Serial Programmer (ISSP)

The CY3207ISSP is a production programmer. It includes protection circuitry and an industrial case that is more robust than the MiniProg in a production programming environment.

Note that CY3207ISSP needs special software and is not compatible with PSoC Programmer. The kit includes:

- CY3207 Programmer Unit
- PSoC ISSP Software CD
- 110 ~ 240 V Power Supply, Euro-Plug Adapter
- USB 2.0 Cable

Accessories (Emulation and Programming)

Table 40. Emulation and Programming Accessories

Part Number	Pin Package	Flex-Pod Kit ^[50]	Foot Kit ^[51]	Adapter ^[52]
CY8C20236A-24LKXI	16-pin QFN (No E-Pad)	CY3250-20246QFN	CY3250-20246QFN-POD	See note 49
CY8C20246A-24LKXI	16-pin QFN (No E-Pad)	CY3250-20246QFN	CY3250-20246QFN-POD	See note 52
CY8C20246AS-24LKXI	16-pin QFN (No E-Pad)	Not Supported		
CY8C20336A-24LQXI	24-pin QFN	CY3250-20346QFN	CY3250-20346QFN-POD	See note 49
CY8C20346A-24LQXI	24-pin QFN	CY3250-20346QFN	CY3250-20346QFN-POD	See note 52
CY8C20346AS-24LQXI	24-pin QFN	Not Supported		
CY8C20396A-24LQXI	24-pin QFN	Not Supported		
CY8C20436A-24LQXI	32-pin QFN	CY3250-20466QFN	CY3250-20466QFN-POD	See note 49
CY8C20446A-24LQXI	32-pin QFN	CY3250-20466QFN	CY3250-20466QFN-POD	See note 52
CY8C20446AS-24LQXI	32-pin QFN	Not Supported		
CY8C20466A-24LQXI	32-pin QFN	CY3250-20466QFN	CY3250-20466QFN-POD	See note 52
CY8C20466AS-24LQXI	32-pin QFN	Not Supported		
CY8C20496A-24LQXI	32-pin QFN	Not Supported		
CY8C20536A-24PVXI	48-pin SSOP	CY3250-20566	CY3250-20566-POD	See note 52
CY8C20546A-24PVXI	48-pin SSOP	CY3250-20566	CY3250-20566-POD	See note 52
CY8C20566A-24PVXI	48-pin SSOP	CY3250-20566	CY3250-20566-POD	See note 52

Third Party Tools

Several tools have been specially designed by third-party vendors to accompany PSoC devices during development and production. Specific details for each of these tools can be found at <http://www.cypress.com> under Documentation > Evaluation Boards.

Build a PSoC Emulator into Your Board

For details on how to emulate your circuit before going to volume production using an on-chip debug (OCD) non-production PSoC device, refer Application Note [Debugging - Build a PSoC Emulator into Your Board – AN2323](#).

Notes

50. Flex-Pod kit includes a practice flex-pod and a practice PCB, in addition to two flex-pods.

51. Foot kit includes surface mount feet that can be soldered to the target PCB.

52. Programming adapter converts non-DIP package to DIP footprint. Specific details and ordering information for each of the adapters can be found at <http://www.emulation.com>.

Ordering Information

The following table lists the CY8C20X36A/46A/66A/96A/46AS/66AS PSoC devices' key package features and ordering codes.

Table 41. PSoC Device Key Features and Ordering Information

Package	Ordering Code	Flash (Bytes)	SRAM (Bytes)	CapSense Blocks	Digital I/O Pins	Analog Inputs ^[53]	XRES Pin	USB	ADC
16-pin (3 × 3 × 0.6 mm) QFN (no E-Pad)	CY8C20236A-24LKXI	8 K	1 K	1	13	13	Yes	No	Yes
16-pin (3 × 3 × 0.6 mm) QFN (no E-Pad) (Tape and Reel)	CY8C20236A-24LKXIT	8 K	1 K	1	13	13	Yes	No	Yes
16-pin (3 × 3 × 0.6 mm) QFN (no E-Pad)	CY8C20246A-24LKXI	16 K	2 K	1	13	13	Yes	No	Yes
16-pin (3 × 3 × 0.6 mm) QFN (no E-Pad)	CY8C20246AS-24LKXI	16 K	2 K	1	13	13	Yes	No	Yes
16-pin (3 × 3 × 0.6 mm) QFN (no E-Pad) (Tape and Reel)	CY8C20246A-24LKXIT	16 K	2 K	1	13	13	Yes	No	Yes
16-pin (3 × 3 × 0.6 mm) QFN (no E-Pad) (Tape and Reel)	CY8C20246AS-24LKXIT	16 K	2 K	1	13	13	Yes	No	Yes
24-pin (4 × 4 × 0.6 mm) QFN	CY8C20336A-24LQXI	8 K	1 K	1	20	20	Yes	No	Yes
24-pin (4 × 4 × 0.6 mm) QFN (Tape and Reel)	CY8C20336A-24LQXIT	8 K	1 K	1	20	20	Yes	No	Yes
24-pin (4 × 4 × 0.6 mm) QFN	CY8C20346A-24LQXI	16 K	2 K	1	20	20	Yes	No	Yes
24-pin (4 × 4 × 0.6 mm) QFN	CY8C20346AS-24LQXI	16 K	2 K	1	20	20	Yes	No	Yes
24-pin (4 × 4 × 0.6 mm) QFN (Tape and Reel)	CY8C20346A-24LQXIT	16 K	2 K	1	20	20	Yes	No	Yes
24-pin (4 × 4 × 0.6 mm) QFN (Tape and Reel)	CY8C20346AS-24LQXIT	16 K	2 K	1	20	20	Yes	No	Yes
24-pin (4 × 4 × 0.6 mm) QFN	CY8C20396A-24LQXI	16 K	2 K	1	19	19	Yes	Yes	Yes
24-pin (4 × 4 × 0.6 mm) QFN (Tape and Reel)	CY8C20396A-24LQXIT	16 K	2 K	1	19	19	Yes	Yes	Yes
32-pin (5 × 5 × 0.6 mm) QFN	CY8C20436A-24LQXI	8 K	1 K	1	28	28	Yes	No	Yes
32-pin (5 × 5 × 0.6 mm) QFN (Tape and Reel)	CY8C20436A-24LQXIT	8 K	1 K	1	28	28	Yes	No	Yes
32-pin (5 × 5 × 0.6 mm) QFN	CY8C20446A-24LQXI	16 K	2 K	1	28	28	Yes	No	Yes
32-pin (5 × 5 × 0.6 mm) QFN	CY8C20446AS-24LQXI	16 K	2 K	1	28	28	Yes	No	Yes
32-pin (5 × 5 × 0.6 mm) QFN (Tape and Reel)	CY8C20446A-24LQXIT	16 K	2 K	1	28	28	Yes	No	Yes
32-pin (5 × 5 × 0.6 mm) QFN (Tape and Reel)	CY8C20446AS-24LQXIT	16 K	2 K	1	28	28	Yes	No	Yes
32-pin (5 × 5 × 0.6 mm) QFN	CY8C20466A-24LQXI	32 K	2 K	1	28	28	Yes	No	Yes
32-pin (5 × 5 × 0.6 mm) QFN	CY8C20466AS-24LQXI	32 K	2 K	1	28	28	Yes	No	Yes
32-pin (5 × 5 × 0.6 mm) QFN (Tape and Reel)	CY8C20466A-24LQXIT	32 K	2 K	1	28	28	Yes	No	Yes
32-pin (5 × 5 × 0.6 mm) QFN (Tape and Reel)	CY8C20466AS-24LQXIT	32 K	2 K	1	28	28	Yes	No	Yes
32-pin (5 × 5 × 0.6 mm) QFN	CY8C20496A-24LQXI	16 K	2 K	1	25	25	Yes	Yes	Yes
32-pin (5 × 5 × 0.6 mm) QFN (Tape and Reel)	CY8C20496A-24LQXIT	16 K	2 K	1	25	25	Yes	Yes	Yes

Table 41. PSoC Device Key Features and Ordering Information (continued)

Package	Ordering Code	Flash (Bytes)	SRAM (Bytes)	CapSense Blocks	Digital I/O Pins	Analog Inputs ^[53]	XRES Pin	USB	ADC
48-pin SSOP ^[54]	CY8C20536A-24PVXI ^[54]	8 K	1 K	1	34	34	Yes	No	Yes
48-pin SSOP (Tape and Reel) ^[54]	CY8C20536A-24PVXIT ^[54]	8 K	1 K	1	34	34	Yes	No	Yes
48-pin SSOP ^[54]	CY8C20546A-24PVXI ^[54]	16 K	2 K	1	34	34	Yes	No	Yes
48-pin SSOP (Tape and Reel) ^[54]	CY8C20546A-24PVXIT ^[54]	16 K	2 K	1	34	34	Yes	No	Yes
48-pin SSOP ^[54]	CY8C20566A-24PVXI ^[54]	32 K	2 K	1	34	34	Yes	No	Yes
48-pin SSOP (Tape and Reel) ^[54]	CY8C20566A-24PVXIT ^[54]	32 K	2 K	1	34	34	Yes	No	Yes
48-pin (6 × 6 × 0.6 mm) QFN	CY8C20636A-24LQXI	8 K	1 K	1	36	36	Yes	No	Yes
48-pin (6 × 6 × 0.6 mm) QFN (Tape and Reel)	CY8C20636A-24LQXIT	8 K	1 K	1	36	36	Yes	No	Yes
48-pin (7 × 7 × 1.0 mm) QFN ^[54]	CY8C20636A-24LTXI ^[54]	8 K	1 K	1	36	36	Yes	No	Yes
48-pin (7 × 7 × 1.0 mm) QFN (Tape and Reel) ^[54]	CY8C20636A-24LTXIT ^[54]	8 K	1 K	1	36	36	Yes	No	Yes
48-pin (6 × 6 × 0.6 mm) QFN	CY8C20646A-24LQXI	16 K	2 K	1	36	36	Yes	Yes	Yes
48-pin (6 × 6 × 0.6 mm) QFN (Tape and Reel)	CY8C20646A-24LQXIT	16 K	2 K	1	36	36	Yes	Yes	Yes
48-pin (7 × 7 × 1.0 mm) QFN ^[54]	CY8C20646A-24LTXI ^[54]	16 K	2 K	1	36	36	Yes	Yes	Yes
48-pin (7 × 7 × 1.0 mm) QFN (Tape and Reel) ^[54]	CY8C20646A-24LTXIT ^[54]	16 K	2 K	1	36	36	Yes	Yes	Yes
48-pin (6 × 6 × 0.6 mm) QFN	CY8C20666A-24LQXI	32 K	2 K	1	36	36	Yes	Yes	Yes
48-pin (6 × 6 × 0.6 mm) QFN (Tape and Reel)	CY8C20666A-24LQXIT	32 K	2 K	1	36	36	Yes	Yes	Yes
48-pin (7 × 7 × 1.0 mm) QFN ^[54]	CY8C20666A-24LTXI ^[54]	32 K	2 K	1	36	36	Yes	Yes	Yes
48-pin (7 × 7 × 1.0 mm) QFN (Tape and Reel) ^[54]	CY8C20666A-24LTXIT ^[54]	32 K	2 K	1	36	36	Yes	Yes	Yes
48-pin (7 × 7 × 1.0 mm) QFN (Tape and Reel) ^[54]	CY8C20666AS-24LTXI ^[54]	32 K	2 K	1	36	36	Yes	Yes	Yes
48-pin (7 × 7 × 1.0 mm) QFN (Tape and Reel) ^[54]	CY8C20666AS-24LTXIT ^[54]	32 K	2 K	1	36	36	Yes	Yes	Yes
48-pin (7 × 7 × 1.0 mm) QFN (Tape and Reel) ^[54]	CY8C20666AS-24LTXIT ^[54]	32 K	2 K	1	36	36	Yes	Yes	Yes
48-pin (7 × 7 × 1.0 mm) QFN (OCD) ^[53]	CY8C20066A-24LTXI ^[53]	32 K	2 K	1	36	36	Yes	Yes	Yes
30-ball WLCSP	CY8C20746A-24FDXC	16 K	1 K	1	27	27	Yes	No	Yes
30-ball WLCSP (Tape and Reel)	CY8C20746A-24FDXCT	16 K	1 K	1	27	27	Yes	No	Yes
30-ball WLCSP	CY8C20766A-24FDXC	32 K	2 K	1	27	27	Yes	No	Yes
30-ball WLCSP (Tape and Reel)	CY8C20766A-24FDXCT	32 K	2 K	1	27	27	Yes	No	Yes
24-pin (4 × 4 × 0.6 mm) QFN	CY8C20336AN-24LQXI	8 K	1 K	1	20	20	Yes	No	No
24-pin (4 × 4 × 0.6 mm) QFN (Tape and Reel)	CY8C20336AN-24LQXIT	8 K	1 K	1	20	20	Yes	No	No
32-pin (5 × 5 × 0.6 mm) QFN	CY8C20436AN-24LQXI	8 K	1 K	1	28	28	Yes	No	No
32-pin (5 × 5 × 0.6 mm) QFN (Tape and Reel)	CY8C20436AN-24LQXIT	8 K	1 K	1	28	28	Yes	No	No
48-pin (7 × 7 × 1.0 mm) QFN ^[54]	CY8C20636AN-24LTXI ^[54]	8 K	1 K	1	36	36	Yes	No	No
48-pin (7 × 7 × 1.0 mm) QFN (Tape and Reel) ^[54]	CY8C20636AN-24LTXIT ^[54]	8 K	1 K	1	36	36	Yes	No	No

Table 41. PSoC Device Key Features and Ordering Information (continued)

Package	Ordering Code	Flash (Bytes)	SRAM (Bytes)	CapSense Blocks	Digital I/O Pins	Analog Inputs ^[53]	XRES Pin	USB	ADC
16-pin (3 × 3 × 0.6 mm) QFN (no E-Pad)	CY8C20246AS-24LKXI	16 K	2 K	1	13	13	Yes	No	Yes
16-pin (3 × 3 × 0.6 mm) QFN (no E-Pad, Tape and Reel)	CY8C20246AS-24LKXIT	16 K	2 K	1	13	13	Yes	No	Yes
24-pin (4 × 4 × 0.6 mm) QFN	CY8C20346AS-24LQXI	16 K	2 K	1	20	20	Yes	No	Yes
24-pin (4 × 4 × 0.6 mm) QFN (Tape and Reel)	CY8C20346AS-24LQXIT	16 K	2 K	1	20	20	Yes	No	Yes
32-pin (5 × 5 × 0.6 mm) QFN	CY8C20446AS-24LQXI	16 K	2 K	1	28	28	Yes	No	Yes
32-pin (5 × 5 × 0.6 mm) QFN (Tape and Reel)	CY8C20446AS-24LQXIT	16 K	2 K	1	28	28	Yes	No	Yes
32-pin (5 × 5 × 0.6 mm) QFN	CY8C20466AS-24LQXI	32 K	2 K	1	28	28	Yes	No	Yes
32-pin (5 × 5 × 0.6 mm) QFN (Tape and Reel)	CY8C20466AS-24LQXIT	32 K	2 K	1	28	28	Yes	No	Yes
48-pin (6 × 6 × 0.6 mm) QFN	CY8C20666AS-24LQXI	32 K	2 K	1	36	36	Yes	Yes	Yes
48-pin (6 × 6 × 0.6 mm) QFN (Tape and Reel)	CY8C20666AS-24LQXIT	32 K	2 K	1	36	36	Yes	Yes	Yes
48-pin (7 × 7 × 1.0 mm) QFN ^[54]	CY8C20666AS-24LTXI ^[54]	32 K	2 K	1	36	36	Yes	Yes	Yes
48-pin (7 × 7 × 1.0 mm) QFN (Tape and Reel) ^[54]	CY8C20666AS-24LTXIT ^[54]	32 K	2 K	1	36	36	Yes	Yes	Yes
48-pin (6 × 6 × 0.6 mm) QFN	CY8C20646AS-24LQXI	16 K	2 K	1	36	36	Yes	Yes	Yes
48-pin (6 × 6 × 0.6 mm) QFN (Tape and Reel)	CY8C20646AS-24LQXIT	16 K	2 K	1	36	36	Yes	Yes	Yes
48-pin (7 × 7 × 1.0 mm) QFN ^[54]	CY8C20646AS-24LTXI ^[54]	16 K	2 K	1	36	36	Yes	Yes	Yes
48-pin (7 × 7 × 1.0 mm) QFN (Tape and Reel) ^[54]	CY8C20646AS-24LTXIT ^[54]	16 K	2 K	1	36	36	Yes	Yes	Yes

Ordering Code Definitions

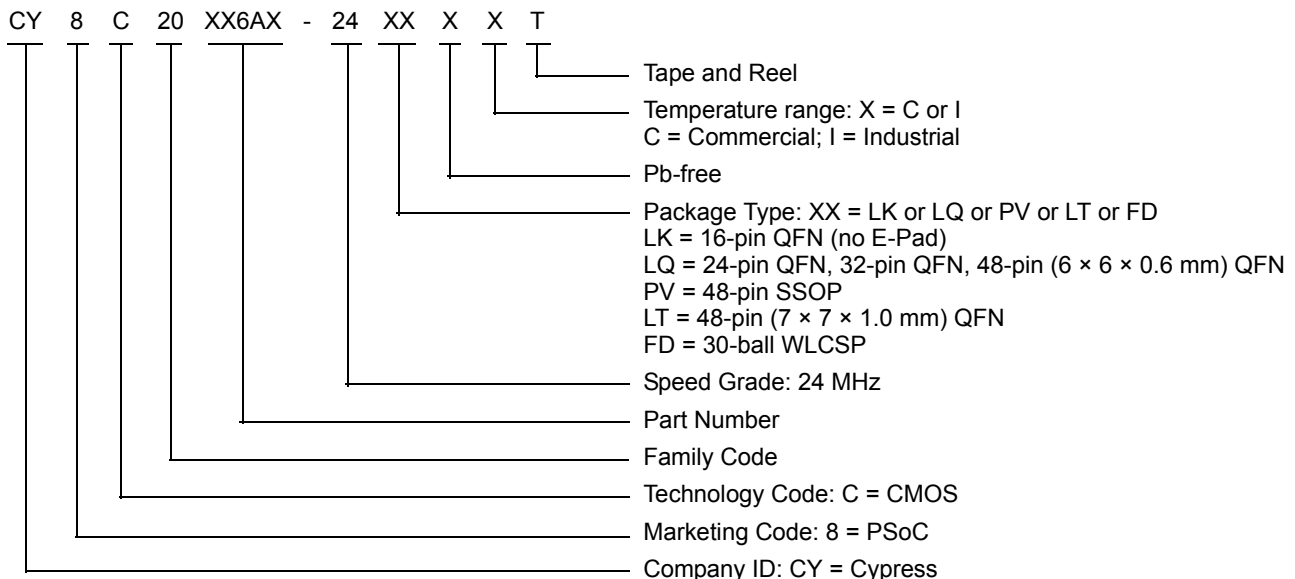

Notes

- 53. Dual-function Digital I/O Pins also connect to the common analog mux.
- 54. Not Recommended for New Designs.

Acronyms

Table 42. Acronyms Used in this Document

Acronym	Description
AC	alternating current
ADC	analog-to-digital converter
API	application programming interface
CMOS	complementary metal oxide semiconductor
CPU	central processing unit
DAC	digital-to-analog converter
DC	direct current
EOP	end of packet
FSR	full scale range
GPIO	general purpose input/output
GUI	graphical user interface
I ² C	inter-integrated circuit
ICE	in-circuit emulator
IDAC	digital analog converter current
ILO	internal low speed oscillator
IMO	internal main oscillator
I/O	input/output
ISSP	in-system serial programming
LCD	liquid crystal display
LDO	low dropout (regulator)
LSB	least-significant bit
LVD	low voltage detect
MCU	micro-controller unit
MIPS	mega instructions per second
MISO	master in slave out
MOSI	master out slave in
MSB	most-significant bit
OCD	on-chip debugger
POR	power on reset
PPOR	precision power on reset
PSRR	power supply rejection ratio
PWRSYS	power system
PSoC [®]	Programmable System-on-Chip
SLIMO	slow internal main oscillator
SRAM	static random access memory
SNR	signal to noise ratio
QFN	quad flat no-lead
SCL	serial I2C clock
SDA	serial I2C data
SDATA	serial ISSP data
SPI	serial peripheral interface
SS	slave select
SSOP	shrink small outline package
TC	test controller
USB	universal serial bus
USB D+	USB Data+
USB D-	USB Data-
WLCSP	wafer level chip scale package
XTAL	crystal

Reference Documents

- *Technical reference manual for CY8C20xx6 devices*
- *In-system Serial Programming (ISSP) protocol for 20xx6 (AN2026C)*
- *Host Sourced Serial Programming for 20xx6 devices (AN59389)*

Document Conventions

Units of Measure

Table 43. Units of Measure

Symbol	Unit of Measure
°C	degree Celsius
dB	decibels
fF	femtofarad
g	gram
Hz	hertz
KB	1024 bytes
Kbit	1024 bits
KHz	kilohertz
Ksps	kilo samples per second
kΩ	kilohm
MHz	megahertz
MΩ	megaohm
μA	microampere
μF	microfarad
μH	microhenry
μs	microsecond
μW	microwatt
mA	milliampere
ms	millisecond
mV	millivolt
nA	nanoampere
nF	nanofarad
ns	nanosecond
nV	nanovolt
W	ohm
pA	picoampere
pF	picofarad
pp	peak-to-peak
ppm	parts per million
ps	picosecond
sps	samples per second
s	sigma: one standard deviation
V	volt
W	watt

Numeric Naming

Hexadecimal numbers are represented with all letters in uppercase with an appended lowercase 'h' (for example, '14h' or '3Ah'). Hexadecimal numbers may also be represented by a '0x' prefix, the C coding convention. Binary numbers have an appended lowercase 'b' (for example, '01010100b' or '01000011b'). Numbers not indicated by an 'h', 'b', or 0x are decimal.

Glossary

Crosspoint connection	Connection between any GPIO combination via analog multiplexer bus.
Differential non-linearity	Ideally, any two adjacent digital codes correspond to output analog voltages that are exactly one LSB apart. Differential non-linearity is a measure of the worst case deviation from the ideal 1 LSB step.
Hold time	Hold time is the time following a clock event during which the data input to a latch or flip-flop must remain stable in order to guarantee that the latched data is correct.
I ² C	It is a serial multi-master bus used to connect low speed peripherals to MCU.
Integral nonlinearity	It is a term describing the maximum deviation between the ideal output of a DAC/ADC and the actual output level.
Latch-up current	Current at which the latch-up test is conducted according to JESD78 standard (at 125 degree Celsius)
Power supply rejection ratio (PSRR)	The PSRR is defined as the ratio of the change in supply voltage to the corresponding change in output voltage of the device.
Scan	The conversion of all sensor capacitances to digital values.
Setup time	Period required to prepare a device, machine, process, or system for it to be ready to function.
Signal-to-noise ratio	The ratio between a capacitive finger signal and system noise.
SPI	Serial peripheral interface is a synchronous serial data link standard.

Document History Page

Document Title: CY8C20X36A/46A/66A/96A/46AS/66AS, 1.8 V CapSense® Controller with SmartSense™ Auto-tuning Document Number: 001-54459				
Rev.	ECN	Orig. of Change	Submission Date	Description of Change
**	2737924	SNV	07/14/09	New silicon and document
*A	2764528	MATT	09/16/2009	Updated AC Chip Level Specifications Updated ADC User Module Electrical Specifications table Added Note 5. Added SR _{POWER_UP} parameter. Updated Ordering information. Updated Capacitance on Crystal Pins
*B	2803229	VZD	11/10/09	Added Contents on page 3 . Added Note 6 on page 20. Edited Features section to include reference to Incremental ADC.
*C	2846083	DST / KEJO	01/12/2010	Updated AC Programming Specifications on page 30 per CDT 56531. Updated Idd typical values in DC Chip-Level Specifications on page 20 . Added 30-pin WLCSP pin and package details. Added Contents on page 2.
*D	2935141	KEJO / ISW / SSHH	03/05/2010	Updated Features on page 1 . Added SmartSense on page 4 . Updated PSoC® Functional Overview on page 4 . Removed SNR statement regarding on page 4 (Analog Multiplexer section). Updated on page 7 with the I2C enhanced slave interface point. Removed references to “system level” in Designing with PSoC Designer on page 8 . Changed TC CLK and TC DATA to ISSP CLK and ISSP DATA respectively in all the pinouts. Modified notes in Pinouts. Updated 30-ball pin diagram. Removed IMO frequency trim options diagram in Electrical Specifications on page 19 . Updated and formatted values in DC and AC specifications. Updated Ordering information table. Updated 48-pin SSOP package diagram. Added 30-Ball WLCSP package spec 001-50669. Removed AC Analog Mux Bus Specifications section. Added SPI Master and Slave mode diagrams. Modified Definition for Timing for Fast/Standard Mode on the I2C Bus on page 28 . Updated Thermal Impedances on page 37 . Combined Development Tools with Development Tool Selection on page 38 . Removed references to “system level”. Updated Evaluation Tools on page 38 . Added Ordering Code Definitions on page 42 . Updated Acronyms on page 43 . Added Glossary and Reference Documents on page 43 . Changed datasheet status from Preliminary to Final
*E	3043291	SAAC	09/30/10	Change: Added the line “Supports SmartSense” in the “Low power CapSense® block” bullet in the Features section. Impact: Helps to know that this part has the feature of Auto Tuning. Change: Replaced pod MPNs. Areas affected: Foot kit column of table 37. Change: Template and Styles update. Areas affected: Entire datasheet. Impact: Datasheet adheres to Cypress standards.
*F	3071632	JPX	10/26/10	In Table 36 on page 33 , modified t _{LOW} and t _{HIGH} min values to 42. Updated t _{SS_HIGH} min value to 50; removed max value.

Document History Page (continued)

Document Title: CY8C20X36A/46A/66A/96A/46AS/66AS, 1.8 V CapSense® Controller with SmartSense™ Auto-tuning Document Number: 001-54459				
Rev.	ECN	Orig. of Change	Submission Date	Description of Change
*G	3247491	TTO/JPM/ ARVM/BVI	06/16/11	Add 4 new parameters to Table 14 on page 21 , and 2 new parameters to Table 15 on page 22 . Changed Typ values for the following parameters: I _{DD24} , I _{DD12} , I _{DD6} , V _{OSLPC} . Added footnote # 31 and referred it to pin numbers 1, 14, 15, 42, and 43 under Table 10 on page 18 . Added footnote # 34 and referred it to parameter V _{IOZ} under Table 11 on page 19 . Added “t _{JIT_IMO} ” parameter to Table 27 on page 27 . Included footnote # 44 and added reference to t _{JIT_IMO} specification under Table 27 on page 27 . Updated Solder Reflow Specifications on page 37 as per specs 25-00090 and 25-00103. I _{SB0} Max value changed from 0.5 µA to 1.1 µA in Table 13 on page 20 . Added Table 26 on page 26 . Updated part numbers for “SmartSense_EMC” enabled CapSense controller.
*H	3367332	BTK / SSHH / JPM/TTO/ VMAD	09/09/11	Added parameter “t _{OS} ” to Table 27 on page 27 . Added parameter “I _{SB12C} ” to Table 13 on page 20 . Added Table 24 on page 26 . Added Table 25 on page 26 . Replaced text “Port 2 or 3 pins” with “Port 2 or 3 or 4 pins” in Table 14 , Table 15 , Table 16 , and Table 28 .
*I	3371807	MATT	09/30/2011	Updated Packaging Information (Updated the next revision package outline for Figure 20 , Figure 23 and included a new package outline Figure 25). Updated Ordering Information (Added new part numbers CY8C20636A-24LQXI, CY8C20636A-24LQXIT, CY8C20646A-24LQXI, CY8C20646A-24LQXIT, CY8C20666A-24LQXI, CY8C20666A-24LQXIT, CY8C20666AS-24LQXI, CY8C20666AS-24LQXIT, CY8C20646AS-24LQXI and CY8C20646AS-24LQXIT). Updated in new template.
*J	3401666	MATT	10/11/2011	No technical updates.
*K	3414479	KPOL	10/19/2011	Removed clock stretching feature on page 1. Removed I ² C enhanced slave interface point from Additional System Resources .
*L	3452591	BVI / UDYG	12/01/2011	Changed document title. Updated DC Chip-Level Specifications table. Updated Solder Reflow Specifications section. Updated Getting Started and Designing with PSoC Designer sections. Included Development Tools section. Updated Software under Development Tool Selection section.
*M	3473330	ANBA	12/22/2011	Updated DC Chip-Level Specifications under Electrical Specifications (updated maximum value of I _{SB0} parameter from 1.1 µA to 1.05 µA).
*N	3587003	DST	04/16/2012	Added note for WLCSP package on page 1. Added Sensing inputs to pin table captions. Updated Conditions for DC Reference Buffer Specifications . Updated t _{JIT_IMO} description in AC Chip-Level Specifications . Added note for t _{VDDWAIT} , t _{VDDXRES} , t _{ACQ} , and t _{XRESINI} specs. Removed WLCSP package outline.
*O	3638569	BVI	06/06/2012	Updated F _{SCLK} parameter in the Table 36 , “ SPI Slave AC Specifications ,” on page 33. Changed t _{OUT_HIGH} to t _{OUT_H} in Table 35 , “ SPI Master AC Specifications ,” on page 32. Updated package diagram 001-57280 to *C revision.

Sales, Solutions, and Legal Information

Worldwide Sales and Design Support

Cypress maintains a worldwide network of offices, solution centers, manufacturer's representatives, and distributors. To find the office closest to you, visit us at [Cypress Locations](#).

Products

Automotive	cypress.com/go/automotive
Clocks & Buffers	cypress.com/go/clocks
Interface	cypress.com/go/interface
Lighting & Power Control	cypress.com/go/powerpsoc
	cypress.com/go/plc
Memory	cypress.com/go/memory
Optical & Image Sensing	cypress.com/go/image
PSoC	cypress.com/go/psoc
Touch Sensing	cypress.com/go/touch
USB Controllers	cypress.com/go/USB
Wireless/RF	cypress.com/go/wireless

PSoC Solutions

psoc.cypress.com/solutions
PSoC 1 | PSoC 3 | PSoC 5

© Cypress Semiconductor Corporation, 2009-2012. The information contained herein is subject to change without notice. Cypress Semiconductor Corporation assumes no responsibility for the use of any circuitry other than circuitry embodied in a Cypress product. Nor does it convey or imply any license under patent or other rights. Cypress products are not warranted nor intended to be used for medical, life support, life saving, critical control or safety applications, unless pursuant to an express written agreement with Cypress. Furthermore, Cypress does not authorize its products for use as critical components in life-support systems where a malfunction or failure may reasonably be expected to result in significant injury to the user. The inclusion of Cypress products in life-support systems application implies that the manufacturer assumes all risk of such use and in doing so indemnifies Cypress against all charges.

Any Source Code (software and/or firmware) is owned by Cypress Semiconductor Corporation (Cypress) and is protected by and subject to worldwide patent protection (United States and foreign), United States copyright laws and international treaty provisions. Cypress hereby grants to licensee a personal, non-exclusive, non-transferable license to copy, use, modify, create derivative works of, and compile the Cypress Source Code and derivative works for the sole purpose of creating custom software and or firmware in support of licensee product to be used only in conjunction with a Cypress integrated circuit as specified in the applicable agreement. Any reproduction, modification, translation, compilation, or representation of this Source Code except as specified above is prohibited without the express written permission of Cypress.

Disclaimer: CYPRESS MAKES NO WARRANTY OF ANY KIND, EXPRESS OR IMPLIED, WITH REGARD TO THIS MATERIAL, INCLUDING, BUT NOT LIMITED TO, THE IMPLIED WARRANTIES OF MERCHANTABILITY AND FITNESS FOR A PARTICULAR PURPOSE. Cypress reserves the right to make changes without further notice to the materials described herein. Cypress does not assume any liability arising out of the application or use of any product or circuit described herein. Cypress does not authorize its products for use as critical components in life-support systems where a malfunction or failure may reasonably be expected to result in significant injury to the user. The inclusion of Cypress' product in a life-support systems application implies that the manufacturer assumes all risk of such use and in doing so indemnifies Cypress against all charges.

Use may be limited by and subject to the applicable Cypress software license agreement.