

Hybrid IC Isolation Amplifiers 20 Series

ISOLATION AMPLIFIER

(current and voltage output, output isolation)

Functions & Features

- Being used for printed wiring board installation
- High-linearity
- Low power consumption
- Small installation area in printed wiring board
- Isolation and 1500 V AC dielectric strength between input or power supply and output
- ± 15 V DC power supply
- Current/voltage output type

Typical Applications

- Isolating the fields and output circuit of microprocessor to reduce common mode noise
- Available for manufacturers of small-lot products to omit the development of isolation circuit

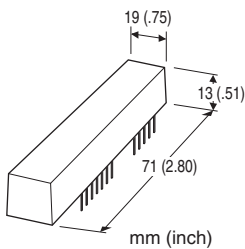

MODEL: 20VS5-207-UB

ORDERING INFORMATION

- Code number: 20VS5-207-UB

INPUT RANGE -5 - +5 V DC

OUTPUT CURRENT RANGE 0 - 20 mA DC

OUTPUT VOLTAGE RANGE -5 - +5 V DC

POWER INPUT

DC Power

UB: ± 15 V DC

GENERAL SPECIFICATIONS

Construction: Hybrid IC

Isolation: Input or power to output

INPUT SPECIFICATIONS

■ DC Voltage

Input : -5.67 - +5.67 V DC

Input resistance: ≥ 1 M Ω (10 k Ω in power failure)

Overload input voltage: ± 30 V DC continuous

Input offset voltage: ± 15 mV

Input bias current: 2 nA TYP. (@25°C)

OUTPUT SPECIFICATIONS

■ DC Current: 0 - 22 mA DC (output of 0 - 5.67 V input)

Current output is not available for negative output.

Load resistance: ≤ 750 Ω @ ± 15 V power input and 20 mA output (power)

Output impedance: ≥ 1 M Ω

■ DC Voltage: -5.5 - +5.5 V DC

Load resistance: ≥ 10 k Ω (max. 0.5 mA)

Output impedance: ≤ 1 Ω

INSTALLATION

Power input

• DC:

Operational voltage range: Rating ± 10 %;

ripple 2 % p-p max.; 41 mA max. @ 20 mA output

Operating temperature: -10 to +70°C (14 to 158°F)

Operating humidity: 30 to 90 %RH (non-condensing)

Mounting: Soldering to the printed wiring board

Weight: 25 g (0.88 oz)

PERFORMANCE in percentage of span

Unless otherwise specified, G = 1.

Linearity

Current output: ± 0.05 % TYP., ± 0.1 % MAX.

at 0 - 20 mA output

Voltage output: ± 0.02 % TYP., ± 0.05 % MAX.

at -5 - +5 V output

Temp. coefficient:

Offset drift 20 ppm/°C

Span drift 50 ppm/°C

Frequency characteristics: Approx. 50 Hz, -3 dB

Response time: ≤ 10 msec. (0 - 90 %)

Conversion gain: $\times 0.97 \pm 2$ %

Gain adjustable range: G = $\times 1$ to $\times 10$

Line voltage effect: ± 0.05 % over voltage range

Insulation resistance: ≥ 100 M Ω with 500 V DC

Dielectric strength:

1500 V AC @ 1 minute (input or power to output)

CMRR: ≥ 100 dB (500 V AC 50/60 Hz)

EXTERNAL DIMENSIONS & TERMINAL ASSIGNMENTS unit: mm (inch)

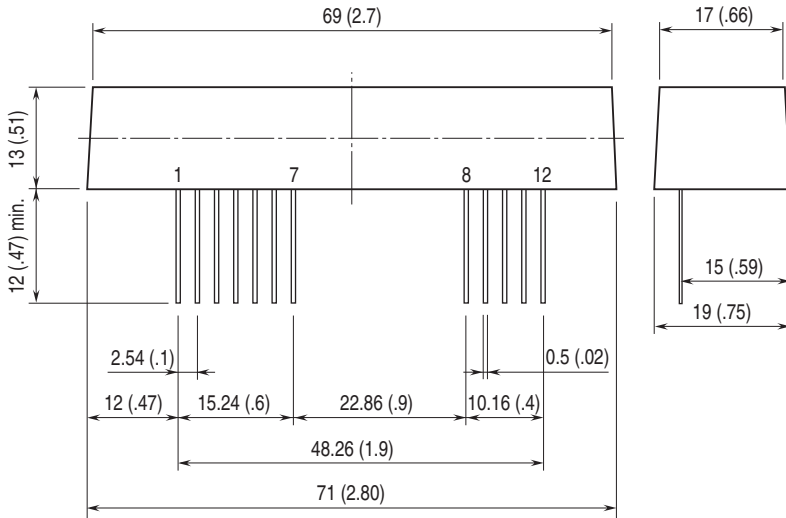

PIN ASSIGNMENT

Pin	Assignment
1	FEEDBACK
2	INVERTING INPUT
3	NON-INVERTING INPUT
4	COM (-)
5	POWER SUPPLY (0V)
6	POWER SUPPLY (-)
7	POWER SUPPLY (+)
8	VOLTAGE OUTPUT (-)
9	VOLTAGE OUTPUT (+)
10	CURRENT OUTPUT (+)
11	CURRENT OUTPUT (-)
12	CURRENT OUTPUT (-)

SCHEMATIC CIRCUITRY & CONNECTION DIAGRAM

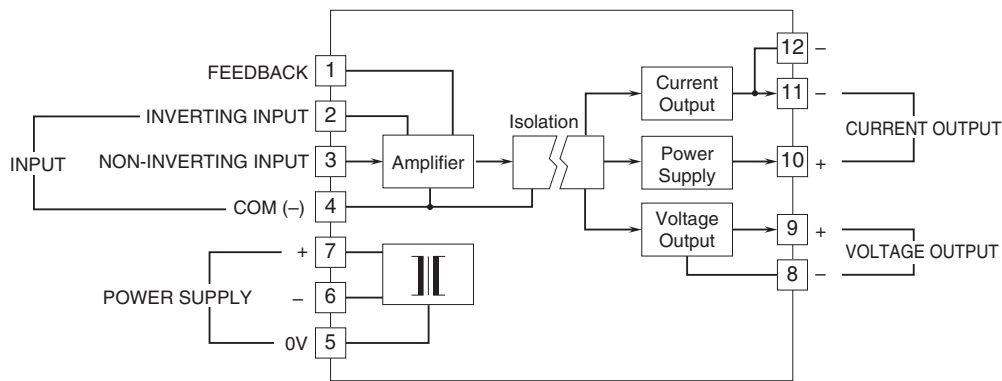

APPLICATION EXAMPLE

The total resistance of the resistors connected to the amplifier must be 20 kΩ minimum and 100 kΩ maximum.

$$(100 \text{ k}\Omega \geq R_1 \times R_2 \div (R_1 + R_2) \geq 20 \text{ k}\Omega)$$

Negative current output is not available.

■ Non-inverting amplifier circuit: Basic example

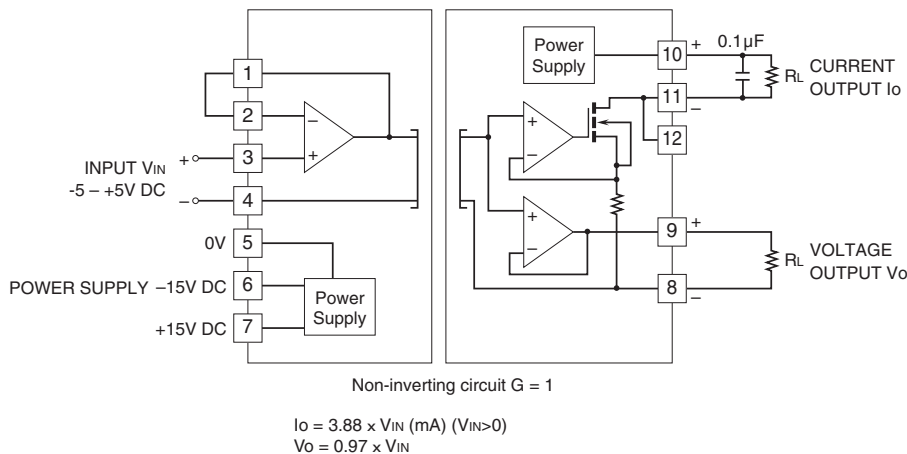

■ Inverting amplifier circuit: Basic example (output inverted to the input)

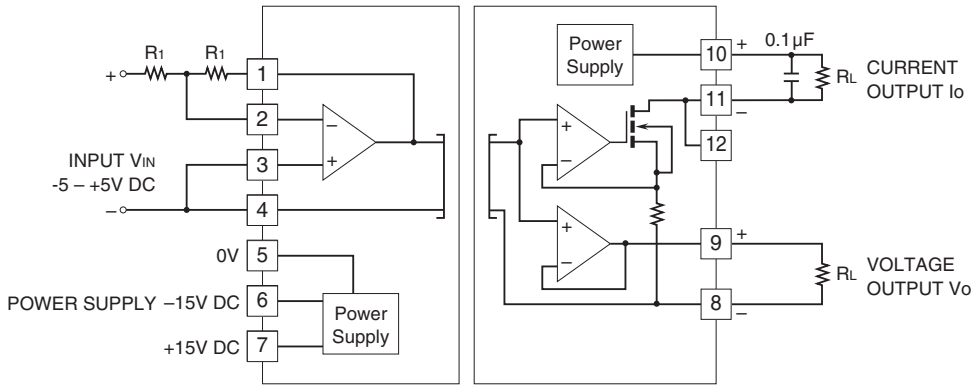

Inverting circuit $G = -1$

$$I_o = -3.88 \times V_{IN} \text{ (mA)} \quad (V_{IN} < 0)$$

$$V_o = -0.97 \times V_{IN}$$

■ Non-inverting amplifier circuit

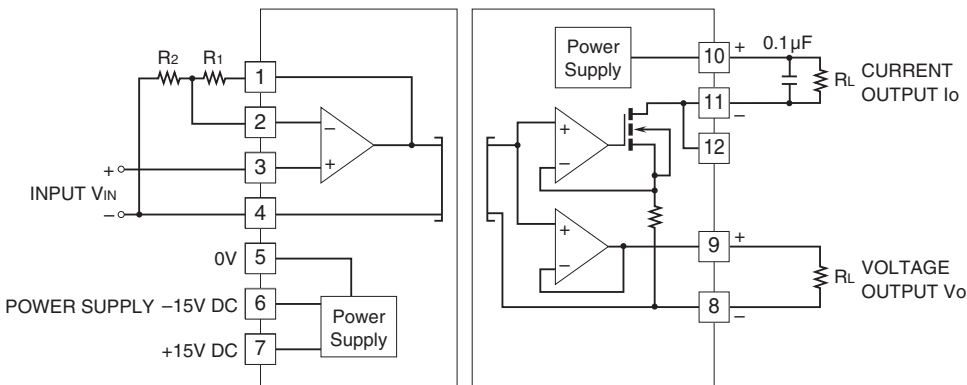

Non-inverting amplifier circuit $G = 1 + R_1/R_2$

$$I_o = 3.88 \times G \times V_{IN} \text{ (mA)} \quad (V_{IN} > 0)$$

$$V_o = 0.97 \times G \times V_{IN}$$

■ Inverting amplifier circuit

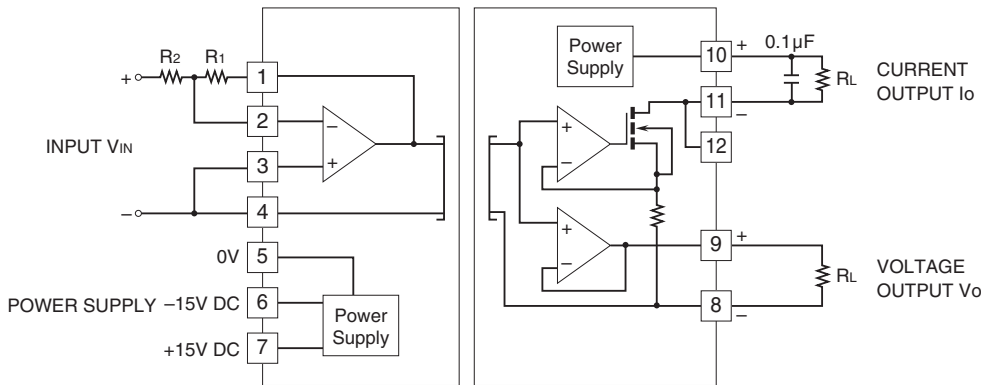

Inverting amplifier circuit $G = -R_1 / R_2$

$$I_o = 3.88 \times G \times V_{IN} \text{ (mA)} \quad (V_{IN} < 0)$$

$$V_o = 0.97 \times G \times V_{IN}$$



Specifications are subject to change without notice.