

5-V, Qi Compliant Wireless Power Transmitter Manager

 Check for Samples: [bq500211](#)

FEATURES

- **Intelligent Control of Wireless Power Transfer**
- **5-V Operation Conforms to Wireless Power Consortium (WPC) Type A5 and Type A11 Transmitter Specifications**
- **Dynamic Power Limiting for USB and Limited Source Operation**
- **Digital Demodulation Reduces Components**
- **Comprehensive Charge Status Mode and Fault Indication**

APPLICATIONS

- **WPC 1.0.3 Compliant Wireless Chargers**
 - Mobile and Smart Phones
 - Handheld Devices
 - Hermetically Sealed Devices and Tools
 - Cars and Other Vehicles
 - Tabletop Charge Surfaces
- See www.ti.com/wirelesspower for More Information on TI's Wireless Charging Solutions

DESCRIPTION

The bq500211 is a second generation digital wireless power controller that integrates all functions required to control wireless power transfer to a single WPC compliant receiver. Designed for 5-V systems, the bq500211 *pings* the surrounding environment for WPC compliant devices to be powered, safely engages the device, receives packet communication from the powered device and manages the power transfer. To maximize flexibility in wireless power applications, Dynamic Power Limiting (DPL) is featured on the BQ500211 wireless-power transmitter manager. DPL enhances user experience by seamlessly optimizing the usage of power available from limited input supplies. The bq500211 can operate as both a WPC type A5 transmitter with a magnetic positioning guide or as a WPC type A11 transmitter without the magnetic guide. With comprehensive status and fault monitoring, should any abnormal condition develop during power transfer, the bq500211 handles it and provides indicator outputs.

The bq500211 is available in a 48-pin, 7 mm x 7 mm QFN package and operates over a temperature range from -40°C to 110°C .

Functional Diagram and Efficiency Versus System Output Power

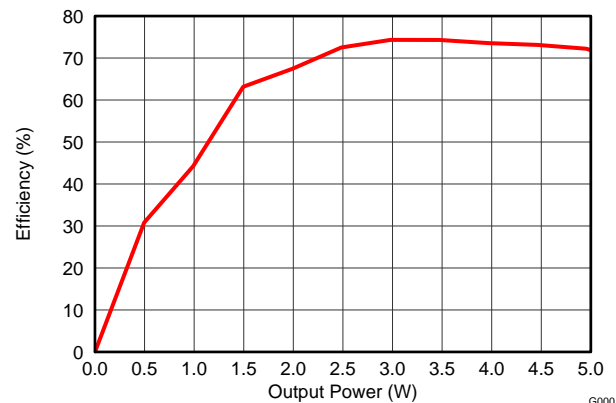
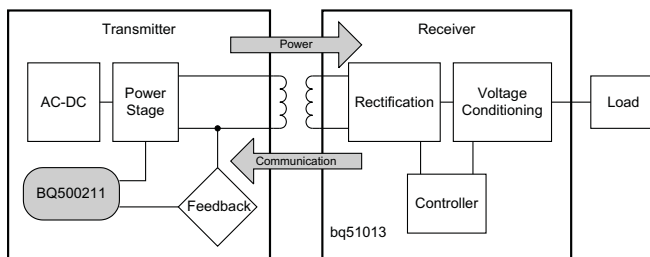

Please be aware that an important notice concerning availability, standard warranty, and use in critical applications of Texas Instruments semiconductor products and disclaimers thereto appears at the end of this data sheet.



These devices have limited built-in ESD protection. The leads should be shorted together or the device placed in conductive foam during storage or handling to prevent electrostatic damage to the MOS gates.

ORDERING INFORMATION⁽¹⁾

OPERATING TEMPERATURE RANGE, T _A	ORDERABLE PART NUMBER	PIN COUNT	SUPPLY	PACKAGE	TOP SIDE MARKING
-40°C to 110°C	bq500211RGZR	48 pin	Reel of 2500	QFN	bq500211
	bq500211RGZT	48 pin	Reel of 250	QFN	bq500211

(1) For the most current package and ordering information, see the Package Option Addendum at the end of this document, or see the TI web site at www.ti.com.

ABSOLUTE MAXIMUM RATINGS⁽¹⁾

over operating free-air temperature range (unless otherwise noted)

	VALUE		UNIT
	MIN	MAX	
Voltage applied at V33D to GND	-0.3	3.6	V
Voltage applied at V33A to GND	-0.3	3.6	
Voltage applied to any pin ⁽²⁾	-0.3	3.6	
Storage temperature, T _{STG}	-40	150	°C

(1) Stresses beyond those listed under *absolute maximum ratings* may cause permanent damage to the device. These are stress ratings only and functional operation of the device at these or any other conditions beyond those indicated under *recommended operating conditions* is not implied. Exposure to absolute-maximum-rated conditions for extended periods may affect device reliability.

(2) All voltages referenced to GND.

RECOMMENDED OPERATING CONDITIONS

over operating free-air temperature range (unless otherwise noted)

		MIN	TYP	MAX	UNIT
V	Supply voltage during operation, V33D, V33A	3.0	3.3	3.6	V
T _A	Operating free-air temperature range	-40		110	°C
T _J	Junction temperature			110	

THERMAL INFORMATION

THERMAL METRIC ⁽¹⁾	bq500211		UNITS
	RGZ		
	48 PINS		
θ _{JA}	Junction-to-ambient thermal resistance ⁽²⁾	28.4	°C/W
θ _{JC(top)}	Junction-to-case(top) thermal resistance ⁽³⁾	14.2	
θ _{JB}	Junction-to-board thermal resistance ⁽⁴⁾	5.4	
ψ _{JT}	Junction-to-top characterization parameter ⁽⁵⁾	0.2	
ψ _{JB}	Junction-to-board characterization parameter ⁽⁶⁾	5.3	
θ _{JC(bottom)}	Junction-to-case(bottom) thermal resistance ⁽⁷⁾	1.4	

- (1) For more information about traditional and new thermal metrics, see the *IC Package Thermal Metrics* application report, [SPRA953](#).
- (2) The junction-to-ambient thermal resistance under natural convection is obtained in a simulation on a JEDEC-standard, high-K board, as specified in JESD51-7, in an environment described in JESD51-2a.
- (3) The junction-to-case (top) thermal resistance is obtained by simulating a cold plate test on the package top. No specific JEDEC standard test exists, but a close description can be found in the ANSI SEMI standard G30-88.
- (4) The junction-to-board thermal resistance is obtained by simulating in an environment with a ring cold plate fixture to control the PCB temperature, as described in JESD51-8.
- (5) The junction-to-top characterization parameter, ψ_{JT}, estimates the junction temperature of a device in a real system and is extracted from the simulation data for obtaining θ_{JA}, using a procedure described in JESD51-2a (sections 6 and 7).
- (6) The junction-to-board characterization parameter, ψ_{JB}, estimates the junction temperature of a device in a real system and is extracted from the simulation data for obtaining θ_{JA}, using a procedure described in JESD51-2a (sections 6 and 7).
- (7) The junction-to-case (bottom) thermal resistance is obtained by simulating a cold plate test on the exposed (power) pad. No specific JEDEC standard test exists, but a close description can be found in the ANSI SEMI standard G30-88.

ELECTRICAL CHARACTERISTICS

over operating free-air temperature range (unless otherwise noted)

PARAMETER		TEST CONDITIONS	MIN	TYP	MAX	UNIT
SUPPLY CURRENT						
I_{V33A}	Supply current	V33A = 3.3 V		8	15	mA
I_{V33D}		V33D = 3.3 V		44	55	
I_{TOTAL}		V33D = V33A = 3.3 V		52	60	
INTERNAL REGULATOR CONTROLLER INPUTS/OUTPUTS						
V33	3.3-V linear regulator	Emitter of NPN transistor	3.25	3.3	3.6	V
V33FB	3.3-V linear regulator feedback			4	4.6	
I_{V33FB}	Series pass base drive	$V_{IN} = 12\text{ V}$; current into V33FB pin		10		mA
Beta	Series NPN pass device		40			
EXTERNALLY SUPPLIED 3.3 V POWER						
V33D	Digital 3.3-V power	$T_A = 25^\circ\text{C}$	3		3.6	V
V33A	Analog 3.3-V power	$T_A = 25^\circ\text{C}$	3		3.6	
V33Slew	V33 slew rate	V33 slew rate between 2.3 V and 2.9 V, V33A = V33D	0.25			V/ms
DIGITAL DEMODULATION INPUTS COMM_A+, COMM_A-, COMM_B+, COMM_B-						
V_{CM}	Common mode voltage each pin		-0.15		1.631	V
COMM+, COMM-	Modulation voltage digital resolution			1		mV
R_{EA}	Input impedance	Ground reference	0.5	1.5	3	M Ω
I_{OFFSET}	Input offset current	1-k Ω source impedance	-5		5	μA
ANALOG INPUTS V_SENSE, I_SENSE, T_SENSE, LED_MODE						
V_{ADDR_OPEN}	Voltage indicating open pin	LED_MODE open	2.37			V
V_{ADDR_SHORT}	Voltage indicating pin shorted to GND	LED_MODE shorted to ground			0.36	
V_{ADC_RANGE}	Measurement range for voltage monitoring	ALL ANALOG INPUTS	0		2.5	
INL	ADC integral nonlinearity		-2.5		2.5	mV
I_{lkg}	Input leakage current	3 V applied to pin			100	nA
R_{IN}	Input impedance	Ground reference	8			M Ω
C_{IN}	Input capacitance				10	pF
DIGITAL INPUTS/OUTPUTS						
V_{OL}	Low-level output voltage	$I_{OL} = 6\text{ mA}$, V33D = 3 V			DGND1 + 0.25	V
V_{OH}	High-level output voltage	$I_{OH} = -6\text{ mA}$, V33D = 3 V		V33D - 0.6V		
V_{IH}	High-level input voltage	V33D = 3V	2.1		3.6	
V_{IL}	Low-level input voltage	V33D = 3.5 V			1.4	
$I_{OH(MAX)}$	Output high source current				4	mA
$I_{OL(MAX)}$	Output low sink current				4	
SYSTEM PERFORMANCE						
V_{RESET}	Voltage where device comes out of reset	V33D Pin	2.3		2.4	V
t_{RESET}	Pulse width needed for reset	RESET pin	2			μs
f_{SW}	Switching Frequency		112		205	kHz
t_{detect}	Time to detect presence of device requesting power				0.5	s
$t_{retention}$	Retention of configuration parameters	$T_J = 25^\circ\text{C}$	100			Years

DEVICE INFORMATION

Functional Block Diagram

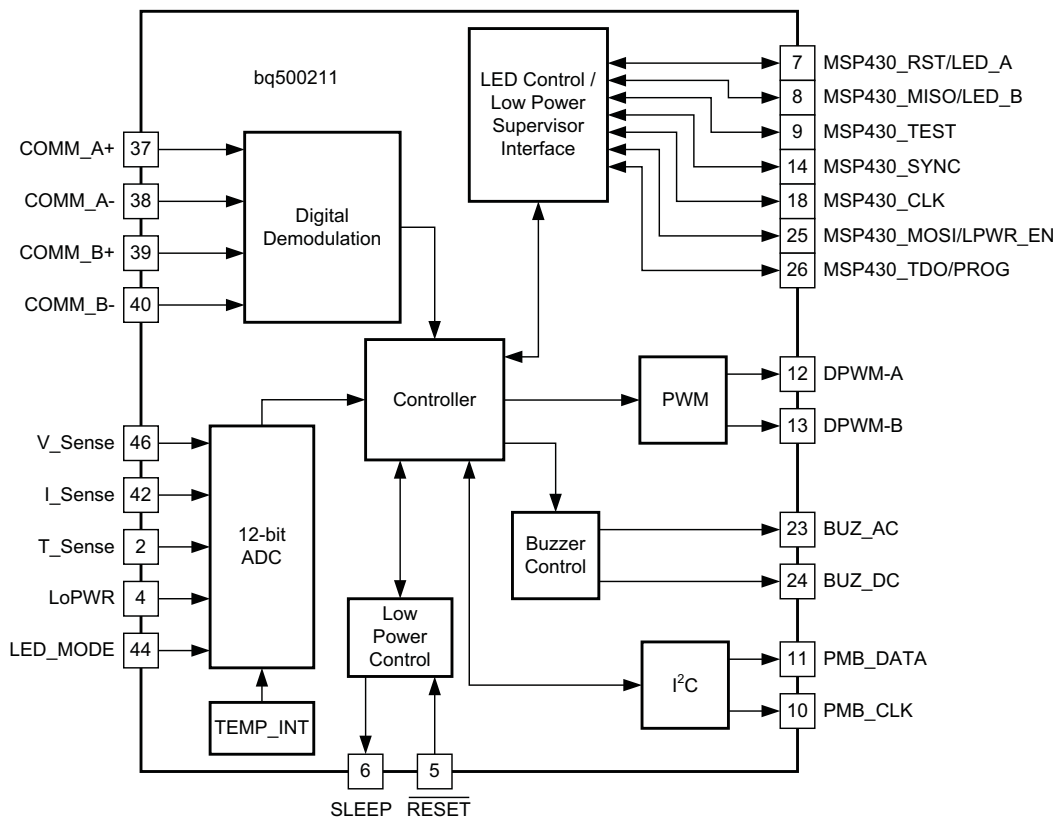

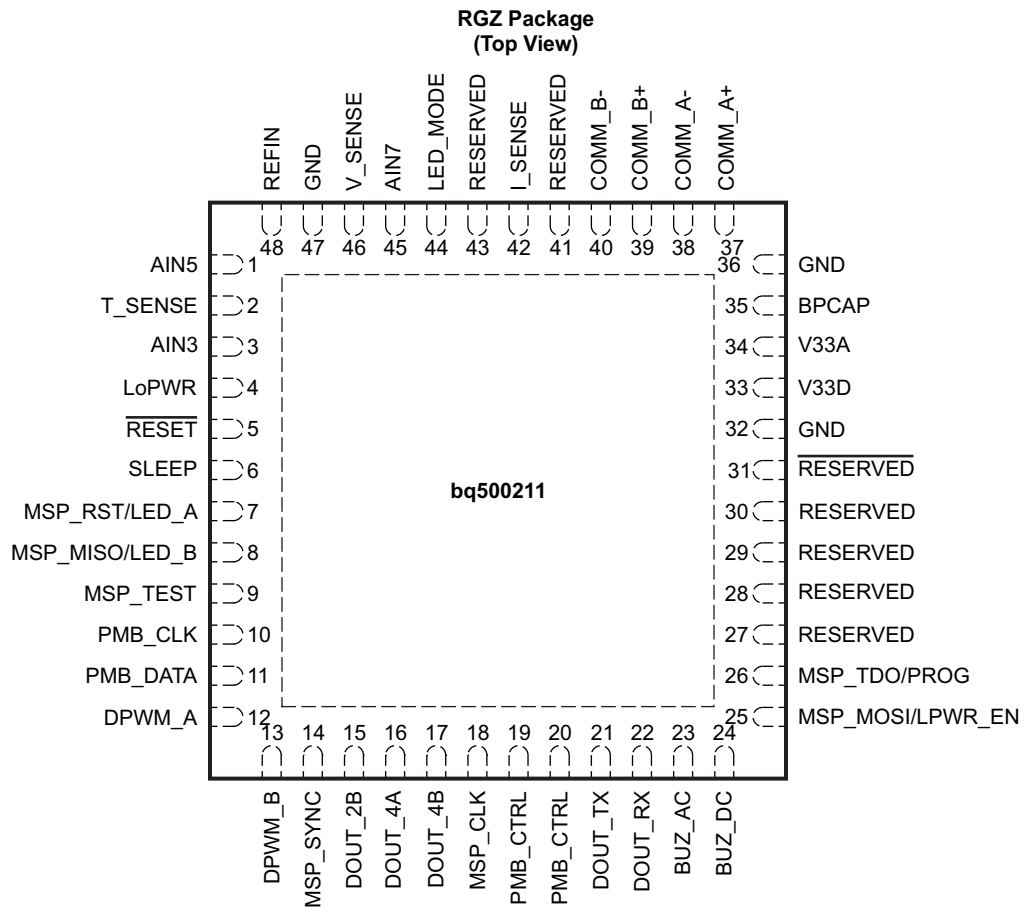

PIN FUNCTIONS

PIN		I/O	DESCRIPTION
NO.	NAME		
3	AIN3	I	This pin can be either connected to GND or left open. Connecting to GND can improve layout grounding.
1	AIN5	I	This pin can be either connected to GND or left open. Connecting to GND can improve layout grounding.
45	AIN7	I	This pin can be either connected to GND or left open. Connecting to GND can improve layout grounding.
35	BPCAP	—	Bypass capacitor for internal 1.8-V core regulator. Connect bypass capacitor to GND.
23	BUZ_AC	O	AC Buzzer Output. Outputs a 400-ms, 4-kHz AC pulse when charging begins.
24	BUZ_DC	O	DC Buzzer Output. Outputs a 400-ms DC pulse when charging begins. This could also be connected to an LED via 470-Ω resistor.
37	COMM_A+	I	Digital demodulation non-inverting input A, connect parallel to input B+.
38	COMM_A-	I	Digital demodulation inverting input A, connect parallel to input B-.
39	COMM_B+	I	Digital demodulation non-inverting input B, connect parallel to input A+.
40	COMM_B-	I	Digital demodulation inverting input B, connect parallel to input A-.
22	DOUT_RX	I	Leave this pin open.
21	DOUT_TX	I	Leave this pin open.
15	DOUT_2B	O	Optional Logic Output 2B. Leave this pin open.
16	DOUT_4A	O	Optional Logic Output 4A. Leave this pin open.
17	DOUT_4B	O	Optional Logic Output 4B. Leave this pin open.
12	DPWM_A	O	PWM Output A, controls one half of the full bridge in a phase-shifted full bridge. Switching deadtimes must be externally generated.
13	DPWM_B	O	PWM Output B, controls other half of the full bridge in a phase-shifted full bridge. Switching deadtimes must be externally generated.
49	EPAD	-	Flood with copper GND plane and stitch vias to PCB internal GND plane.
32	GND	—	GND.
36	GND	—	GND.
47	GND	—	GND.
42	I_SENSE	I	Transmitter input current, used for efficiency calculations. Use 20-mΩ sense resistor and A=50 gain current sense amplifier.
44	LED_MODE	I	Input to select from 4 LED modes.
4	LoPWR	I	Dynamic Power Limiting (DPL) control pin. To set power mode to 500 mA, pull to GND. For full-power operation pull to 3.3-V supply.
18	MSP_CLK	I/O	Used for boot loading the MSP430 low power supervisor. If MSP430 is not used, leave this pin floating.
8	MSP_MISO/LED_B	I	MSP – TMS, SPI-MISO, LED-B -- If external MSP430 is not used, connect to an LED via 470-Ω resistor for status indication.
7	MSP_RST/LED_A	I	MSP – Reset, LED-A -- If external MSP430 is not used, connect to an LED via 470-Ω resistor for status indication.
14	MSP_SYNC	O	MSP SPI_SYNC, if external MSP430 is not used, leave this pin open.
26	MSP_TDO/PROG	I/O	MSP-TDO, MSP430 programmed indication.
9	MSP_TEST	I	MSP – Test, If external MSP430 is not used, leave this pin open.
25	MSP_MOSI/LPWR_EN	I/O	Low standby power supervisor enable. If low power is not needed, connect this to GND.

PIN FUNCTIONS (continued)

PIN		I/O	DESCRIPTION
NO.	NAME		
19	PMB_ALERT	O	Reserved, leave this pin open.
10	PMB_CLK	I/O	10-kΩ pull-up resistor to 3.3-V supply.
20	PMB_CTRL	I	Reserved, connect to GND.
11	PMB_DATA	I/O	10-kΩ pull-up resistor to 3.3-V supply.
48	REFIN	I	External Reference Voltage Input. Connect this input to GND.
27	RESERVED	I/O	Reserved, leave this pin open.
28	RESERVED	I/O	Reserved, leave this pin open.
29	RESERVED	I/O	Reserved, leave this pin open.
30	RESERVED	I/O	Reserved, leave this pin open.
31	RESERVED	I/O	Reserved, connect 10-kΩ pull-down resistor to GND.
41	RESERVED	O	Reserved, leave this pin open.
43	RESERVED	I	Reserved, leave this pin open.
5	RESET	I	Device reset. Use a 10-kΩ to 100-kΩ pull-up resistor to the 3.3-V supply.
6	SLEEP	O	Low-power mode output. Starts low-power ping cycle.
2	T_SENSE	I	Sensor Input. Device shuts down when below 1 V. If not used, keep above 1 V by connecting to the 3.3-V supply.
46	V_SENSE	I	Transmitter input voltage, used for efficiency calculations. Use 76.8-kΩ to 10-kΩ divider to minimize quiescent current.
34	V33A	—	Analog 3.3-V Supply. This pin can be derived from V33D supply, decouple with 10-Ω resistor and additional bypass capacitors
33	V33D	—	Digital core 3.3-V supply. Be sure to decouple with bypass capacitors as close to the part as possible.

Typical Characteristics Curves

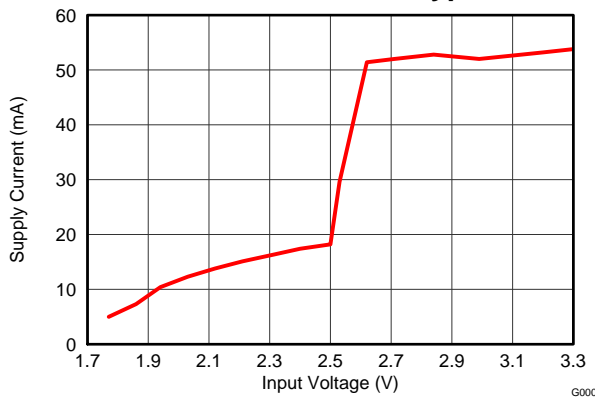

Figure 1. bq500211 Supply Current vs. VCC Voltage

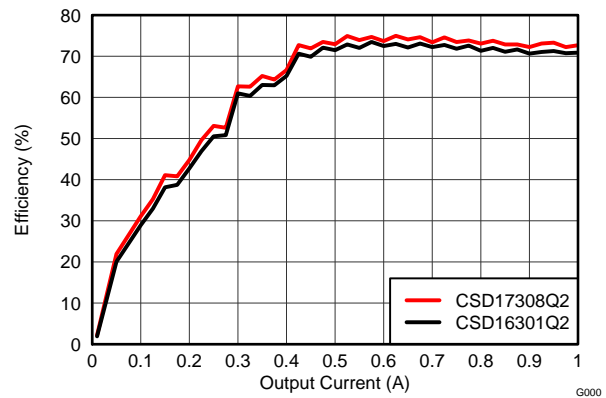

Figure 2. System Efficiency Using Alternate MOSFETs

Principles of Operation

Fundamentals

The principle of wireless power transfer is simply an open cored transformer consisting of primary and secondary coils and associated electronics. The primary coil and electronics are also referred to as the transmitter, and the secondary side the receiver. The transmitter coil and electronics are typically built into a charger pad. The receiver coil and electronics are typically built into a portable device, such as a cell-phone.

When the receiver coil is positioned on the transmitter coil, magnetic coupling occurs when the transmitter coil is driven. The flux is coupled into the secondary coil which induces a voltage, current flows, it is rectified and power can be transferred quite effectively to a load - wirelessly. Power transfer can be managed via any of various familiar closed-loop control schemes.

Wireless Power Consortium (WPC)

The Wireless Power Consortium (WPC) is an international group of companies from diverse industries. The WPC standard was developed to facilitate cross compatibility of compliant transmitters and receivers. The standard defines the physical parameters and the communication protocol to be used in wireless power. For more information, go to www.wirelesspowerconsortium.com.

Power Transfer

Power transfer depends on coil coupling. Coupling is dependant on the distance between coils, alignment, coil dimensions, coil materials, number of turns, magnetic shielding, impedance matching, frequency and duty cycle.

Most importantly, the receiver and transmitter coils must be aligned for best coupling and efficient power transfer. The closer the space between the coils, the better the coupling, but the practical distance is set to be less than 5 mm (as defined within the WPC Specification) to account for housing and interface surfaces.

Shielding is added as a backing to both the transmitter and receiver coils to direct the magnetic field to the coupled zone. Magnetic fields outside the coupled zone do not transfer power. Thus, shielding also serves to contain the fields to avoid coupling to other adjacent system components.

Regulation can be achieved by controlling any one of the coil coupling parameters. For WPC compatibility, the transmitter coils and capacitance are specified and the resonant frequency point is fixed at 100 kHz. Power transfer is regulated by changing the operating frequency between 112 kHz to 205 kHz. The higher the frequency, the further from resonance and the lower the power. Duty cycle remains constant at 50% throughout the power band and is reduced only once 205 kHz is reached.

The WPC standard describes the dimension and materials of the coils. It also has information on tuning the coils to resonance. The value of the inductor and resonant capacitor are critical to proper operation and system efficiency.

Communication

Communication within the WPC is from the receiver to the transmitter, where the receiver tells the transmitter to send power and how much. In order to regulate, the receiver must communicate with the transmitter whether to increase or decrease frequency. The receiver monitors the rectifier output and using Amplitude Modulation (AM), sends packets of information to the transmitter. A packet is comprised of a preamble, a header, the actual message and a checksum, as defined by the WPC standard.

The receiver sends a packet by modulating an impedance network. This AM signal reflects back as a change in the voltage amplitude on the transmitter coil. The signal is demodulated and decoded by the transmitter side electronics and the frequency of its coil drive output is adjusted to close the regulation loop. The bq500211 features internal digital demodulation circuitry.

The modulated impedance network on the receiver can either be resistive or capacitive. [Figure 3](#) shows the resistive modulation approach, where a resistor is periodically added to the load and also shows the resulting change in resonant curve which causes the amplitude change in the transmitter voltage indicated by the two operating points at the same frequency. [Figure 4](#) shows the capacitive modulation approach, where a capacitor is periodically added to the load and also shows the resulting amplitude change in the transmitter voltage.

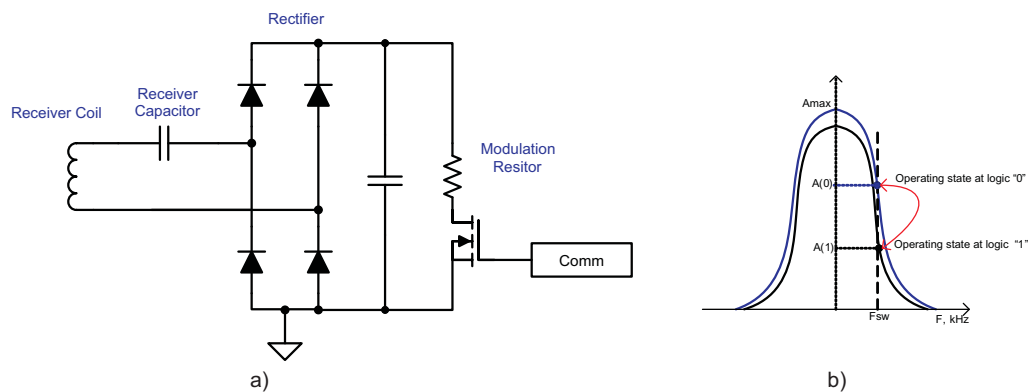

Figure 3. Receiver Resistive Modulation Circuit

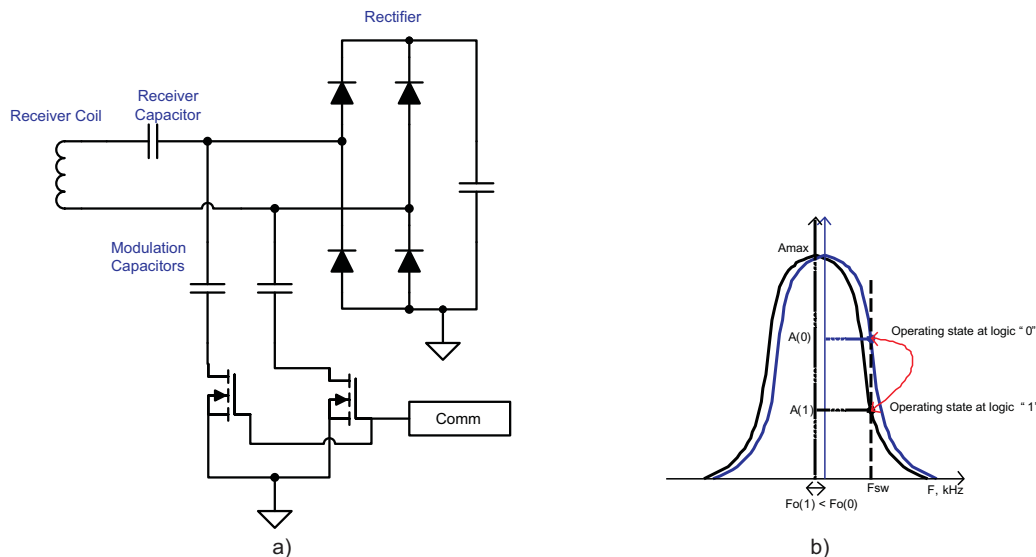

Figure 4. Receiver Capacitive Modulation Circuit

Application Information

Coils and Matching Capacitors

The coil and matching capacitor selection for the transmitter has been established by WPC standard. This is fixed and cannot be changed on the transmitter side. The following is a list of available and compatible A5 transmitter coils:

Table 1. Summary of A5 Transmitter Coils

COIL MANUFACTURER	WPC A5 PART NUMBER (with magnet)	RESONANT TANK CAPACITANCE
Elytone	YT-56886	400 nF/50 V C0G
Mingstar	312-00004	400 nF/50 V C0G
TDK	TTX-52-TIS	400 nF/50 V C0G
Toko	X1415	400 nF/50 V C0G

Capacitor selection is critical to proper system operation. A total capacitance value of 400 nF is required in the resonant tank. This is the WPC system compatibility requirement, not a guideline.

NOTE

A total capacitance value of 400 nF/50 V (C0G dielectric type or equivalent) is required in the resonant tank to achieve a 100-kHz resonance frequency.

The capacitors chosen must be rated for at least 50 V and must be of quality C0G dielectric or equivalent. These are typically available in a 5% tolerance. The use of X7R types or below is not recommended if WPC compliance is required because critical WPC certification testing, such as the minimum modulation requirement, might fail.

A 400-nF capacitor is not a standard value and therefore several must be combined in parallel. The designer can combine a (4 nF x 100 nF) or a (180 nF + 220 nF) along with other combinations depending on market availability. All capacitors must be of high quality C0G type or equivalent and not mixed with lesser dielectric types.

Dynamic Power Limiting

Dynamic Power Limiting (DPL) allows operation from a 5-V supply with limited current capability (such as a USB port). There are two modes of operation selected via an input pin. In the dynamic mode, when the input voltage is observed drooping, the output power is limited to reduce the load and provides margin relative to the supply's capability. The second mode, or constant current mode, is designed specifically for operation from a 500-mA capable USB port, it restricts the output such that the input current remains below the 500-mA limit.

NOTE

Pin 4 must always be terminated, else erratic behavior may result.

Anytime the DPL control loop is regulating the operating point of the transmitter, the LED will indicate that DPL is active. The LED color and flashing pattern are determined by the LED Table. If the receiver sends a Control Error Packet (CEP) with a negative value, (for example, to reduce power to the load), the WPTX in DPL mode will respond to this CEP via the normal WPC control loop.

NOTE

Depending on LED_MODE selected, the power limit indication may be either solid amber (green + red) or solid red.

Option Select Pin

Pin 44 of the bq500211 is dedicated to programming the LED mode of the device. At power-up, an output bias current is applied to this pin to develop a voltage across the programming resistor. The resulting voltage is read by an internal ADC and the bin corresponding to that reading determines the operation mode and blink pattern based on [Table 2](#).

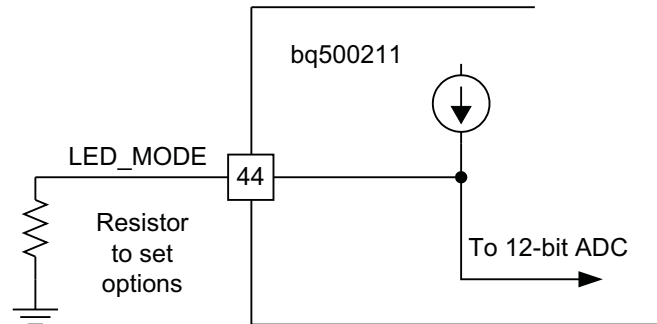

Figure 5. Option Select Pin Programming

LED Indication Modes

The bq500211 can directly drive two LED outputs (pin 7 and pin 8) through a simple current limit resistor (typically 470 Ω), based on the mode selected. The two current limit resistors can be individually adjusted to tune or match the brightness of the two LEDs. Do not exceed the maximum output current rating of the device.

The resistor in [Figure 5](#) connected to pin 44 and GND selects the desired LED indication scheme in [Table 2](#).

Table 2. LED Modes

LED CONTROL OPTION	LED SELECTION RESISTOR	DESCRIPTION	LED	Operational States				
				STANDBY	POWER TRANSFER	CHARGE COMPLETE	FAULT	DYNAMIC POWER LIMITING
X	< 36.5 k Ω	Reserved, do not use	LED1, green	-	-	-	-	-
			LED2, red					
1	42.2 k Ω	Choice number 1	LED1, green	Off	Blink slow	On	Off	Blink slow
			LED2, red	Off	Off	Off	On	Blink slow
2	48.7 k Ω	Choice number 2	LED1, green	On	Blink slow	On	Off	Blink slow
			LED2, red	On	Off	Off	On	Blink slow
3	56.2 k Ω	Choice number 3	LED1, green	Off	Off	On	Off	Off
			LED2, red	Off	On	Off	Blink slow	On
4	64.9 k Ω	Choice number 4	LED1, green	Off	On	Off	Off	Off
			LED2, red	Off	Off	Off	On	Blink slow
	> 75 k Ω	Reserved, all LED off	-	-	-	-	-	-

Shut Down via External Thermal Sensor or Trigger

Typical applications of the bq500211 will not require additional thermal protection. This shutdown feature is provided for enhanced applications and is not only limited to thermal shutdown. The key parameter is the 1.0 V threshold on pin 2. Voltage below 1.0 V on pin 2 causes the device to shutdown.

The application of thermal monitoring via a Negative Temperature Coefficient (NTC) sensor, for example, is straightforward. The NTC forms the lower leg of a temperature dependant voltage divider. The NTC leads are connected to the bq500211 device, pin 2 and GND. The threshold on pin 2 is set to 1.0 V, below which the system shuts down and a fault is indicated (depending on LED mode chosen).

To implement this feature follow these steps:

- 1) Consult the NTC datasheet and find the resistance vs temperature curve.
- 2) Determine the actual temperature where the NTC will be placed by using a thermal probe.
- 3) Read the NTC resistance at that temperature in the NTC datasheet, that is R_{NTC} .
- 4) Use the following formula to determine the upper leg resistor ($R_{Setpoint}$):

$$R_{Setpoint} = 2.3 \times R_{NTC} \tag{1}$$

The system will restore normal operation after approximately five minutes or if the receiver is removed. If the feature is not used, this pin must be pulled high.

NOTE

Pin 2 must always be terminated, else erratic behavior may result.

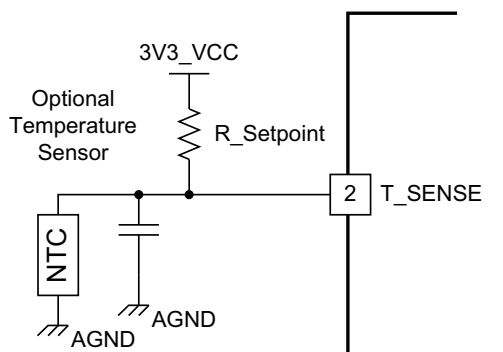

Figure 6. Negative Temperature Coefficient (NTC) Application

Power Transfer Start Signal

The bq500211 features two signal outputs to indicate that power transfer has begun. Pin 23 outputs a 400-ms duration, 4-kHz square wave for driving low cost AC type ceramic buzzers. Pin 24 outputs logic high, also for 400 ms, which is suitable for DC type buzzers with built-in tone generators, or as a trigger for any type of customized indication scheme. If not used, these pins can be left open.

Power-On Reset

The bq500211 has an integrated Power-On Reset (POR) circuit which monitors the supply voltage and handles the correct device startup sequence. Additional supply voltage supervisor or reset circuits are not needed.

External Reset, $\overline{\text{RESET}}$ Pin

The bq500211 can be forced into a reset state by an external circuit connected to the $\overline{\text{RESET}}$ pin. A logic low voltage on this pin holds the device in reset. For normal operation, this pin is pulled up to 3.3 V_{CC} with a 10-k Ω pull-up resistor.

Trickle Charge and CS100

The WPC specification provides an End-of-Power Transfer message (EPT–01) to indicate charge complete. Upon receipt of the charge complete message, the bq500211 will change the LED indication to solid green LED output and halt power transfer for 5 seconds.

In some battery charging applications there is a benefit to continue the charging process in trickle-charge mode to top off the battery. There are several information packets in the WPC specification related to the levels of battery charge (Charge Status). The bq500211 uses these commands to enable top-off charging. The bq500211 changes the LED indication to reflect charge complete when a Charge Status message is 100% received, but unlike the response to an EPT, it will not halt power transfer while the LED is solid green. The mobile device can use a CS100 packet to enable trickle charge mode.

If the reported charge status drops below 90% normal, charging indication will be resumed.

MSP430G2001 Low Power Supervisor

This is an optional low-power feature. By adding the MSP430G2001, the entire bq500211 is periodically shut down to conserve power, yet all relevant states are recalled and all running LED status indicators remain on.

MSP430 Low Power Supervisor Details

Since the bq500211 needs an external low-power mode to significantly reduce power consumption, one way of positively achieving that goal is to remove its supply and completely shut it down. In doing so, however, the bq500211 goes through a reset and any data in memory would be lost. Important information regarding charge state, fault condition and operating mode would be cleared. The MSP430G2001 maintains the LED indication and stores previous charge state during the bq500211 reset period.

The LEDs indicators are now driven by the MSP430G2001, do not exceed the pin output current drive limit.

Using the suggested circuitry, a standby power reduction from 300 mW to less than 90 mW can be expected making it possible to achieve Energy Star rating.

The user does not need to program the MSP430G2001, an off-the-shelf part and any of the available packages can be used as long as the connections are correct. The required MSP430G2001 firmware is embedded in the bq500211 and is boot loaded at first power up, similar to a field update. The MSP430G2001 code cannot be modified by the user.

NOTE

The user cannot program the MSP430G2001 in this system.

All Unused Pins

All unused pins can be left open unless otherwise indicated. Pins 1, 7, 45 can be tied to GND to improve ground shielding. Please refer to the pin definition table for further explanations.

APPLICATION INFORMATION

Overview

The application schematic for the transmitter with reduced standby power is shown in [Figure 7](#).

CAUTION

Please check the bq500211 product page for the most up-to-date application schematic and list of materials package before starting a new design.

Input Regulator

The bq500211 requires 3.3 VDC to operate. A buck regulator or a linear regulator can be used to step down from the 5-V system input. Either choice is fully WPC compatible, the decision lies in the user's requirements with respect to cost or efficiency.

The application example circuit utilizes a low-cost buck regulator, TPS62237, which on account of a 3-MHz switching frequency, can use a 0805 size chip inductor. This results in a very attractive combination, high performance, small size, ease of use and low cost.

Power Train

The bq500211 drives a phase-shifted full bridge. This is essentially twin half bridges and the choice of driver devices is quite simple, a pair of TPS28225 synchronous MOSFET drivers are used with four CSD17308Q2 NexFETs. Other combinations work and system performance with regards to efficiency and EMI emissions vary. Any alternate MOSFETs chosen must be fully saturated at 5-V gate drive and be sure to pay attention whether or not to use gate resistors; some tuning might be required.

Low Power Supervisor

Power reduction is achieved by periodically disabling the bq500211 while LED and housekeeping control functions are continued by U4 – the low-cost, low quiescent current microcontroller MSP430G2001. When U4 is present in the circuit (which is set by a pull-up resistor on bq500211 pin 25), the bq500211 at first power-up boots the MSP430G2001 with the necessary firmware and the two chips operate in tandem. During standby operation, the bq500211 periodically issues a SLEEP command, Q12 pulls the $\overline{\text{RESET}}$ pin low, therefore reducing its power consumption. Meanwhile, the MSP430G2001 maintains the LED indication and stores previous charge state during this bq500211 reset period. This bq500211 reset period is set by the RC time constant network of R26, C22 (from [Figure 7](#)). WPC compliance mandates receive detection within 500 ms, the power transmitter controller, bq500211, awakes every 400 ms to produce an analog ping and check if a valid device is present. Increasing this time constant, therefore is not advised; shortening could result in faster detection time with some decrease in efficiency.

Disabling Low Power Supervisor Mode

For lowest cost or if the low-power supervisor is not needed, please refer to [Figure 8](#) for the application schematic.

NOTE

Current sense shunt and amplifier circuitry are optional. The circuitry is needed to enable Foreign Object Detection (FOD) and a forward migration path to WPC1.1 compliance.

PCB Layout

A good PCB layout is critical to proper system operation and due care should be taken. There are many references on proper PCB layout techniques.

Generally speaking, the system layout will require a 4-layer PCB layout, although a 2-layer PCB layout can be achieved. A proven and recommended approach to the layer stack-up has been:

- Layer 1, component placement and as much ground plane as possible.
- Layer 2, clean ground.
- Layer 3, finish routing.
- Layer 4, clean ground.

Thus, the circuitry is virtually sandwiched between grounds. This minimizes EMI noise emissions and also provides a noise free voltage reference plane for device operation.

Keep as much copper as possible. Make sure the bq500211 GND pins and the power pad have a continuous flood connection to the ground plane. The power pad should also be stitched to the ground plane, which also acts as a heat sink for the bq500211. A good GND reference is necessary for proper bq500211 operation, such as analog-digital conversion, clock stability and best overall EMI performance.

Separate the analog ground plane from the power ground plane and use only one tie point to connect grounds. Having several tie points defeats the purpose of separating the grounds.

The COMM return signal from the resonant tank should be routed as a differential pair. This is intended to reduce stray noise induction. The frequencies of concern warrant low-noise analog signaling techniques, such as differential routing and shielding, but the COMM signal lines do not need to be impedance matched.

Typically a single chip controller solution with integrated power FET and synchronous rectifier will be used. To create a tight loop, pull in the buck inductor and power loop as close as possible. Likewise, the power-train, full-bridge components should be pulled together as tight as possible. See the bq500211EVM-045, bqTESLA Wireless Power TX EVM User's Guide ([Texas Instruments Literature Number SLVU536](#)) for layout examples.

References

Building a Wireless Power Transmitter, SLUA635

Technology, Wireless Power Consortium. <http://www.wirelesspowerconsortium.com/>

An Introduction to the Wireless Power Consortium Standard and TI's Compliant Solutions, Johns, Bill.

[BQ500210 Datasheet](#)

[BQ51013 Datasheet](#)

Typical Application Diagram

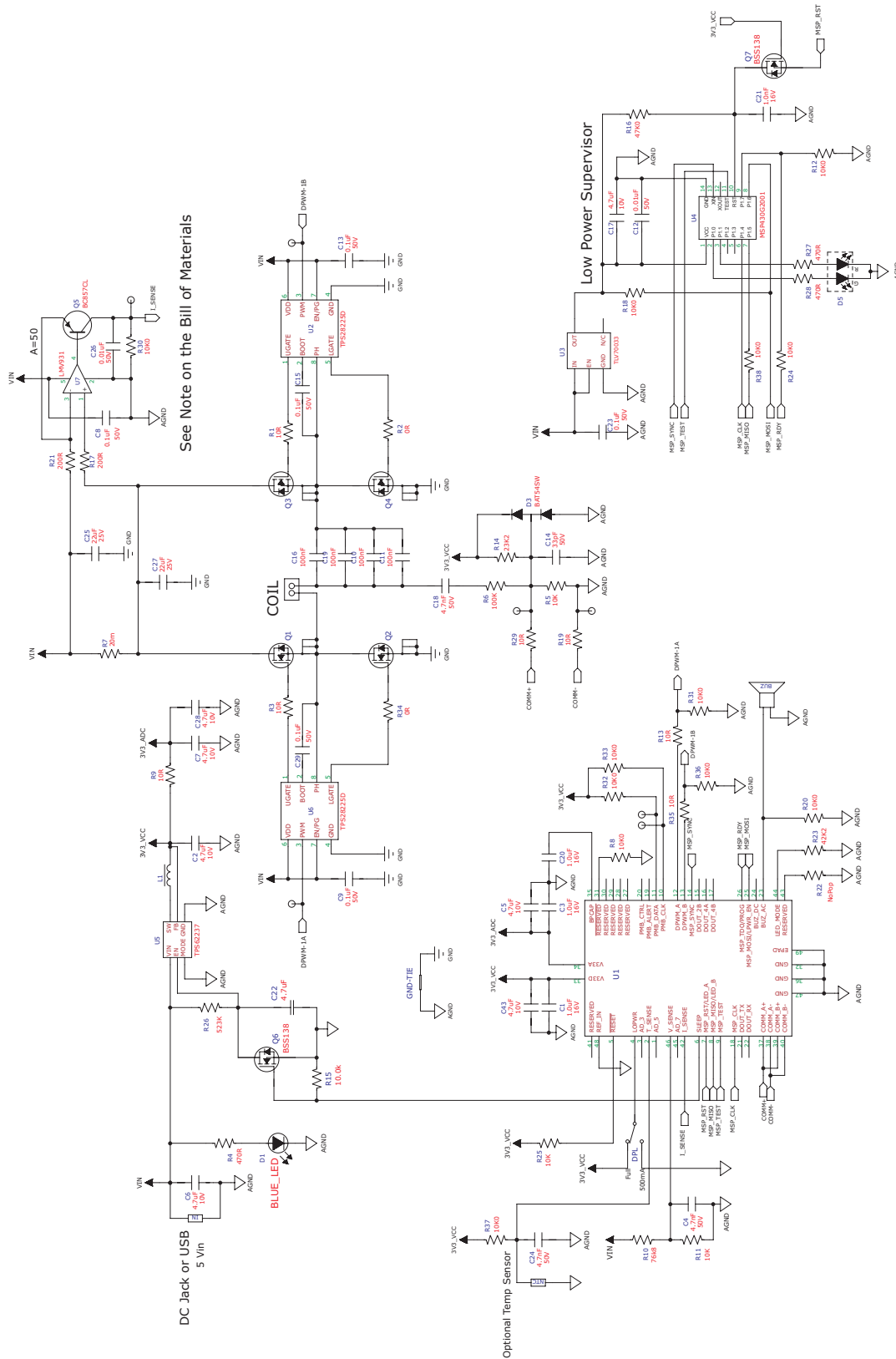

Figure 7. bq500211 Typical Low-Standby Power Application Diagram

PACKAGING INFORMATION

Orderable Device	Status ⁽¹⁾	Package Type	Package Drawing	Pins	Package Qty	Eco Plan ⁽²⁾	Lead/ Ball Finish	MSL Peak Temp ⁽³⁾	Samples (Requires Login)
BQ500211RGZR	ACTIVE	VQFN	RGZ	48	2500	Green (RoHS & no Sb/Br)	CU NIPDAU	Level-3-260C-168 HR	
BQ500211RGZT	ACTIVE	VQFN	RGZ	48	250	Green (RoHS & no Sb/Br)	CU NIPDAU	Level-3-260C-168 HR	

⁽¹⁾ The marketing status values are defined as follows:

ACTIVE: Product device recommended for new designs.

LIFEBUY: TI has announced that the device will be discontinued, and a lifetime-buy period is in effect.

NRND: Not recommended for new designs. Device is in production to support existing customers, but TI does not recommend using this part in a new design.

PREVIEW: Device has been announced but is not in production. Samples may or may not be available.

OBsolete: TI has discontinued the production of the device.

⁽²⁾ Eco Plan - The planned eco-friendly classification: Pb-Free (RoHS), Pb-Free (RoHS Exempt), or Green (RoHS & no Sb/Br) - please check <http://www.ti.com/productcontent> for the latest availability information and additional product content details.

TBD: The Pb-Free/Green conversion plan has not been defined.

Pb-Free (RoHS): TI's terms "Lead-Free" or "Pb-Free" mean semiconductor products that are compatible with the current RoHS requirements for all 6 substances, including the requirement that lead not exceed 0.1% by weight in homogeneous materials. Where designed to be soldered at high temperatures, TI Pb-Free products are suitable for use in specified lead-free processes.

Pb-Free (RoHS Exempt): This component has a RoHS exemption for either 1) lead-based flip-chip solder bumps used between the die and package, or 2) lead-based die adhesive used between the die and leadframe. The component is otherwise considered Pb-Free (RoHS compatible) as defined above.

Green (RoHS & no Sb/Br): TI defines "Green" to mean Pb-Free (RoHS compatible), and free of Bromine (Br) and Antimony (Sb) based flame retardants (Br or Sb do not exceed 0.1% by weight in homogeneous material)

⁽³⁾ MSL, Peak Temp. -- The Moisture Sensitivity Level rating according to the JEDEC industry standard classifications, and peak solder temperature.

Important Information and Disclaimer: The information provided on this page represents TI's knowledge and belief as of the date that it is provided. TI bases its knowledge and belief on information provided by third parties, and makes no representation or warranty as to the accuracy of such information. Efforts are underway to better integrate information from third parties. TI has taken and continues to take reasonable steps to provide representative and accurate information but may not have conducted destructive testing or chemical analysis on incoming materials and chemicals. TI and TI suppliers consider certain information to be proprietary, and thus CAS numbers and other limited information may not be available for release.

In no event shall TI's liability arising out of such information exceed the total purchase price of the TI part(s) at issue in this document sold by TI to Customer on an annual basis.

TAPE AND REEL INFORMATION

REEL DIMENSIONS

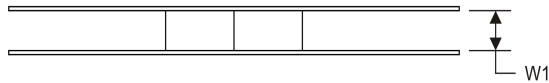
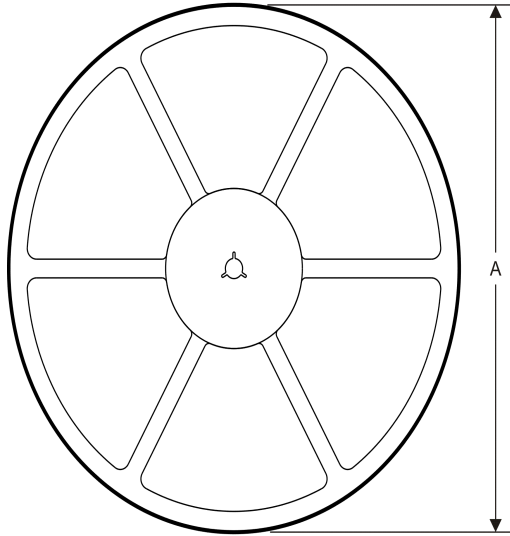

TAPE DIMENSIONS

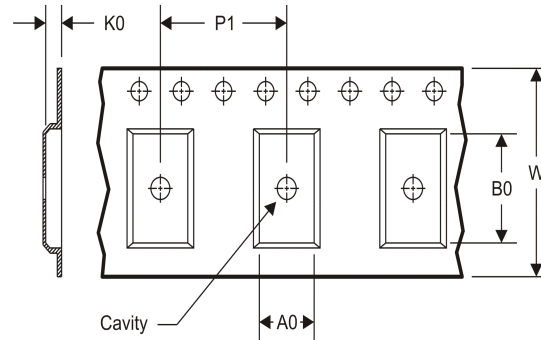

A0	Dimension designed to accommodate the component width
B0	Dimension designed to accommodate the component length
K0	Dimension designed to accommodate the component thickness
W	Overall width of the carrier tape
P1	Pitch between successive cavity centers

TAPE AND REEL INFORMATION

*All dimensions are nominal

Device	Package Type	Package Drawing	Pins	SPQ	Reel Diameter (mm)	Reel Width W1 (mm)	A0 (mm)	B0 (mm)	K0 (mm)	P1 (mm)	W (mm)	Pin1 Quadrant
BQ500211RGZR	VQFN	RGZ	48	2500	330.0	16.4	7.3	7.3	1.5	12.0	16.0	Q2
BQ500211RGZT	VQFN	RGZ	48	250	180.0	16.4	7.3	7.3	1.5	12.0	16.0	Q2

TAPE AND REEL BOX DIMENSIONS

*All dimensions are nominal

Device	Package Type	Package Drawing	Pins	SPQ	Length (mm)	Width (mm)	Height (mm)
BQ500211RGZR	VQFN	RGZ	48	2500	367.0	367.0	38.0
BQ500211RGZT	VQFN	RGZ	48	250	210.0	185.0	35.0

RGZ (S-PVQFN-N48)

PLASTIC QUAD FLATPACK NO-LEAD

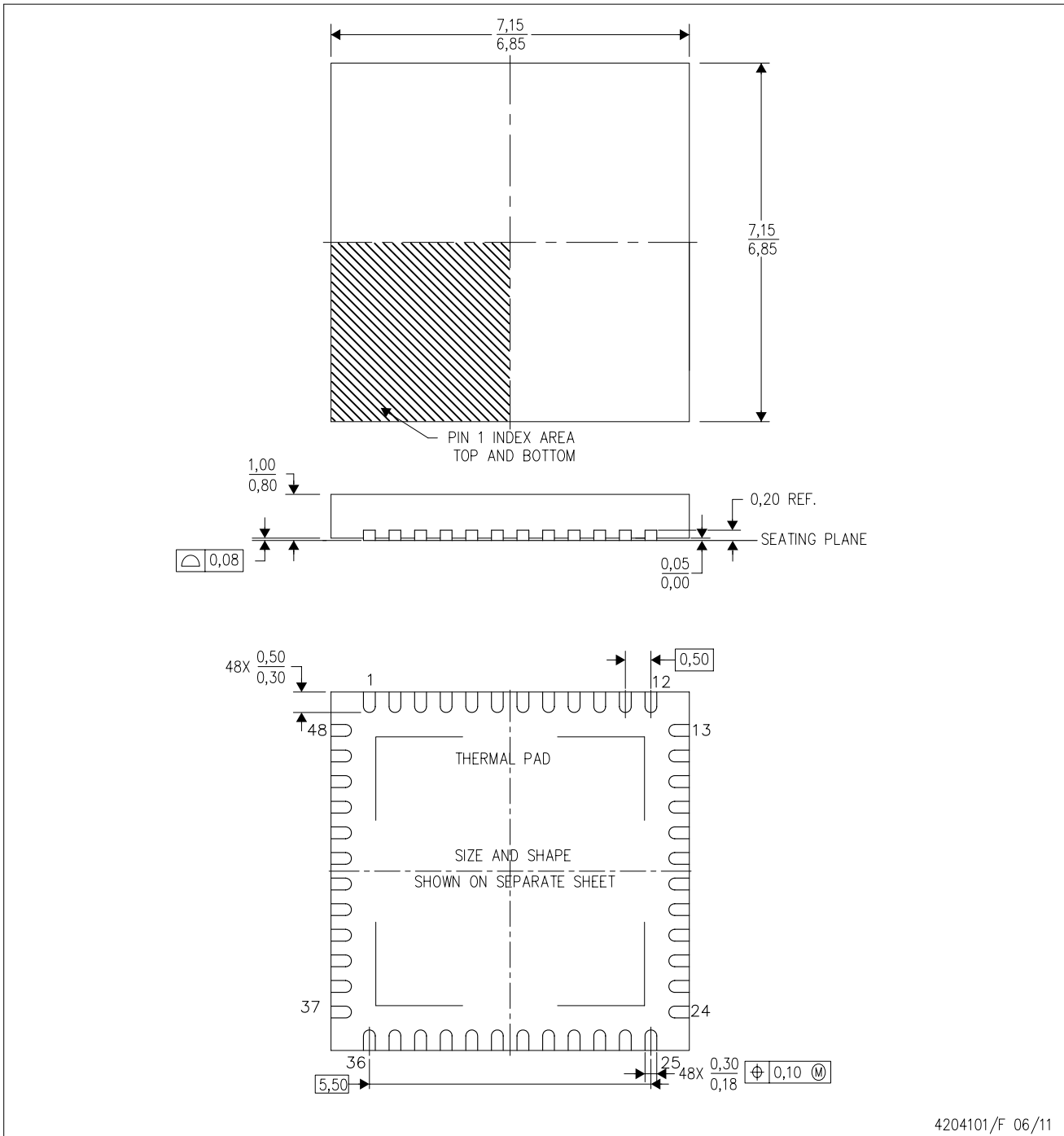

4204101/F 06/11

- NOTES:
- A. All linear dimensions are in millimeters. Dimensioning and tolerancing per ASME Y14.5M-1994.
 - B. This drawing is subject to change without notice.
 - C. Quad Flatpack, No-leads (QFN) package configuration.
 - D. The package thermal pad must be soldered to the board for thermal and mechanical performance.
 - E. See the additional figure in the Product Data Sheet for details regarding the exposed thermal pad features and dimensions.
 - F. Falls within JEDEC MO-220.

THERMAL INFORMATION

This package incorporates an exposed thermal pad that is designed to be attached directly to an external heatsink. The thermal pad must be soldered directly to the printed circuit board (PCB). After soldering, the PCB can be used as a heatsink. In addition, through the use of thermal vias, the thermal pad can be attached directly to the appropriate copper plane shown in the electrical schematic for the device, or alternatively, can be attached to a special heatsink structure designed into the PCB. This design optimizes the heat transfer from the integrated circuit (IC).

For information on the Quad Flatpack No-Lead (QFN) package and its advantages, refer to Application Report, QFN/SON PCB Attachment, Texas Instruments Literature No. SLUA271. This document is available at www.ti.com.

The exposed thermal pad dimensions for this package are shown in the following illustration.

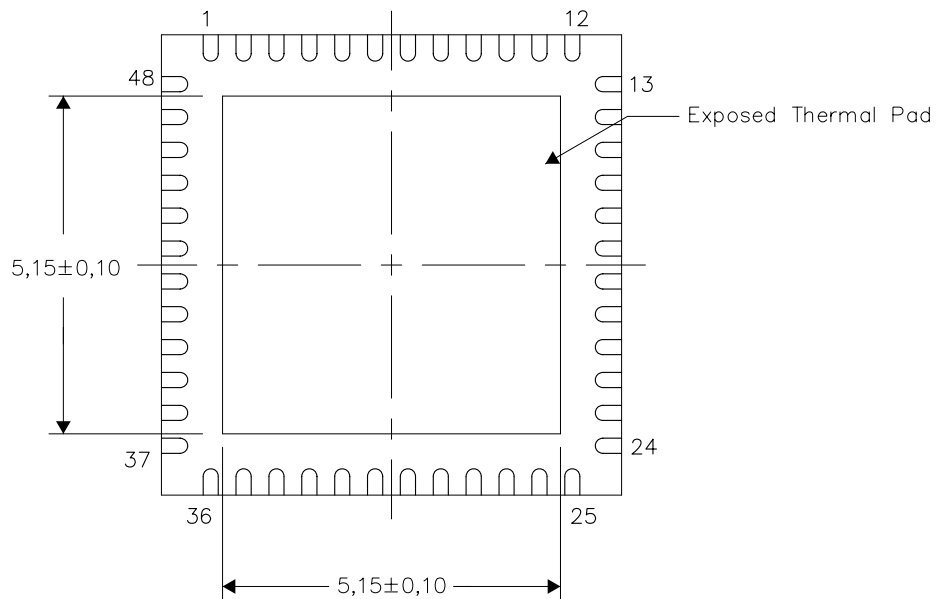

Bottom View

Exposed Thermal Pad Dimensions

4206354-2/R 08/11

NOTE: All linear dimensions are in millimeters

IMPORTANT NOTICE

Texas Instruments Incorporated and its subsidiaries (TI) reserve the right to make corrections, enhancements, improvements and other changes to its semiconductor products and services per JESD46C and to discontinue any product or service per JESD48B. Buyers should obtain the latest relevant information before placing orders and should verify that such information is current and complete. All semiconductor products (also referred to herein as "components") are sold subject to TI's terms and conditions of sale supplied at the time of order acknowledgment.

TI warrants performance of its components to the specifications applicable at the time of sale, in accordance with the warranty in TI's terms and conditions of sale of semiconductor products. Testing and other quality control techniques are used to the extent TI deems necessary to support this warranty. Except where mandated by applicable law, testing of all parameters of each component is not necessarily performed.

TI assumes no liability for applications assistance or the design of Buyers' products. Buyers are responsible for their products and applications using TI components. To minimize the risks associated with Buyers' products and applications, Buyers should provide adequate design and operating safeguards.

TI does not warrant or represent that any license, either express or implied, is granted under any patent right, copyright, mask work right, or other intellectual property right relating to any combination, machine, or process in which TI components or services are used. Information published by TI regarding third-party products or services does not constitute a license to use such products or services or a warranty or endorsement thereof. Use of such information may require a license from a third party under the patents or other intellectual property of the third party, or a license from TI under the patents or other intellectual property of TI.

Reproduction of significant portions of TI information in TI data books or data sheets is permissible only if reproduction is without alteration and is accompanied by all associated warranties, conditions, limitations, and notices. TI is not responsible or liable for such altered documentation. Information of third parties may be subject to additional restrictions.

Resale of TI components or services with statements different from or beyond the parameters stated by TI for that component or service voids all express and any implied warranties for the associated TI component or service and is an unfair and deceptive business practice. TI is not responsible or liable for any such statements.

Buyer acknowledges and agrees that it is solely responsible for compliance with all legal, regulatory and safety-related requirements concerning its products, and any use of TI components in its applications, notwithstanding any applications-related information or support that may be provided by TI. Buyer represents and agrees that it has all the necessary expertise to create and implement safeguards which anticipate dangerous consequences of failures, monitor failures and their consequences, lessen the likelihood of failures that might cause harm and take appropriate remedial actions. Buyer will fully indemnify TI and its representatives against any damages arising out of the use of any TI components in safety-critical applications.

In some cases, TI components may be promoted specifically to facilitate safety-related applications. With such components, TI's goal is to help enable customers to design and create their own end-product solutions that meet applicable functional safety standards and requirements. Nonetheless, such components are subject to these terms.

No TI components are authorized for use in FDA Class III (or similar life-critical medical equipment) unless authorized officers of the parties have executed a special agreement specifically governing such use.

Only those TI components which TI has specifically designated as military grade or "enhanced plastic" are designed and intended for use in military/aerospace applications or environments. Buyer acknowledges and agrees that any military or aerospace use of TI components which have **not** been so designated is solely at the Buyer's risk, and that Buyer is solely responsible for compliance with all legal and regulatory requirements in connection with such use.

TI has specifically designated certain components which meet ISO/TS16949 requirements, mainly for automotive use. Components which have not been so designated are neither designed nor intended for automotive use; and TI will not be responsible for any failure of such components to meet such requirements.

Products

Audio	www.ti.com/audio
Amplifiers	amplifier.ti.com
Data Converters	dataconverter.ti.com
DLP® Products	www.dlp.com
DSP	dsp.ti.com
Clocks and Timers	www.ti.com/clocks
Interface	interface.ti.com
Logic	logic.ti.com
Power Mgmt	power.ti.com
Microcontrollers	microcontroller.ti.com
RFID	www.ti-rfid.com
OMAP Mobile Processors	www.ti.com/omap
Wireless Connectivity	www.ti.com/wirelessconnectivity

Applications

Automotive and Transportation	www.ti.com/automotive
Communications and Telecom	www.ti.com/communications
Computers and Peripherals	www.ti.com/computers
Consumer Electronics	www.ti.com/consumer-apps
Energy and Lighting	www.ti.com/energy
Industrial	www.ti.com/industrial
Medical	www.ti.com/medical
Security	www.ti.com/security
Space, Avionics and Defense	www.ti.com/space-avionics-defense
Video and Imaging	www.ti.com/video

TI E2E Community e2e.ti.com