

Rechargeable Solid State Bare Die Batteries

Features

- All Solid State Construction
- Designed for Wirebond Attachment
- Lead-Free Reflow Tolerant
- Thousands of Recharge Cycles
- Low Self-Discharge
- Fast Recharge
- Eco-friendly, RoHS Tested Compliant
- Smallest Commercially Available Rechargeable Energy Storage Device
- Flat Output Voltage Profile
- 100% Non-cytotoxic

Electrical Properties

Output voltage (nominal): 3.8V
 Capacity (nominal): 5μAh, 50μAh
 Charging source: 4.1V
 Recharge time to 80%: Varies by device
 Charge/discharge cycles: >5000 at 10% discharge

Physical Properties

Die size (mm): Varies by device
 Operating temperature: -40 °C to 70 °C
 Storage temperature: -40 °C to 125 °C

Applications

- **Standby supply** for non-volatile SRAM, real-time clocks, controllers, supply supervisors, and other system-critical components.
- **Portable devices** requiring ultra-slim profile and small footprint backup power source.
- **Localized power source** to keep microcontrollers and other devices alert in standby mode.
- **Power bridging** to provide backup power to system during exchange of main battery.
- **Internet of Things** - EnerChips used as primary rechargeable system power for devices such as wireless sensors and micro-Wearables
- **Medical, Health and Fitness** - EnerChip batteries are ideal for these applications as the EnerChip battery has been tested in vitro and in vivo settings and shown to be 100% non-cytotoxic.

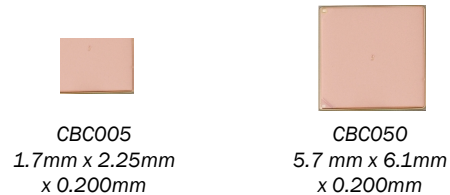

EnerChip™ bare die batteries are solid state, thin film, rechargeable energy storage devices rated at 5μAh and 50μAh at 3.8V. They are ideal as an integrated power source for power backup or primary rechargeable applications. EnerChip bare die are the smallest and thinnest rechargeable energy storage devices available to Original Equipment Manufacturers (OEMs) and are a superior alternative to coin cell batteries and super-capacitors for many handheld, sensors and wearable systems.

The mounting footprint of EnerChip bare die are less than legacy energy storage devices and up to 15 times thinner than a coin cell battery in a holder. Small dimensions make the EnerChips ideal for space-constrained applications.

Because of their solid state design, EnerChip™ energy storage devices are able to withstand solder reflow temperatures and can be processed in high-volume manufacturing lines similar to conventional semiconductor devices. In contrast to traditional rechargeable batteries and super-capacitors, there are no harmful gases, liquids or special disposal procedures associated with the EnerChip.

EnerChip bare die are based on a patented, all solid state, rechargeable lithium cell with a nominal 3.8V output. Recharge is fast and simple with a direct connection to a 4.1V voltage source and no current limiting components are required. Recharge time averages 20 minutes to 80% capacity. A robust design offers thousands of charge/discharge cycles. The EnerChip bare die have two wirebondable pads for co-packaging with other components or chip-on-board mounting. Die are shipped as full wafers, dice and ground on tape backing or in waffle packs.

Operating Characteristics - CBC005

| PARAMETER | | CONDITION | MIN | TYPICAL | MAX | UNITS |
|---|-------|------------------------|-------------------------------|--------------------|---------------------|------------|
| Discharge Cutoff Voltage | | 25 °C | 3.0 ⁽¹⁾ | - | - | V |
| Charge Voltage | | 25 °C | 4.0 ⁽²⁾ | 4.1 | 4.3 | V |
| Pulse Discharge Current | | 25 °C | Variable - see App. Note 1025 | | | - |
| Self-Discharge (5-yr. average; 25 °C) | | Non-recoverable | - | 2.5 | - | % per year |
| | | Recoverable | - | 1.5 ⁽³⁾ | - | % per year |
| Operating Temperature | | - | -40 | 25 | +70 | °C |
| Storage Temperature | | - | -40 | - | +125 ⁽⁴⁾ | °C |
| Cell Resistance (25 °C) | | Charge cycle 2 | - | 7 | 11 | kΩ |
| | | Charge cycle 1000 | - | 30 | 60 | |
| Recharge Cycles (to 80% of rated capacity; 4.1V charge voltage) | 25 °C | 10% depth-of-discharge | 5000 | - | - | cycles |
| | | 50% depth-of-discharge | 1000 | - | - | cycles |
| | 40 °C | 10% depth-of-discharge | 2500 | - | - | cycles |
| | | 50% depth-of-discharge | 500 | - | - | cycles |
| Recharge Time (to 80% of rated capacity; 4.1V charge voltage; 25 °C) ⁽⁵⁾ | | Charge cycle 2 | - | 11 | 22 | minutes |
| | | Charge cycle 1000 | - | 45 | 70 | |
| Capacity | | 40nA discharge; 25 °C | 5 | - | - | μAh |

- (1) Failure to cutoff the discharge voltage at 3.0V will result in EnerChip performance degradation.
- (2) Charging at 4.0V will charge the cell to approximately 70% of its rated capacity.
- (3) First month recoverable self-discharge is 4% average.
- (4) Storage temperature is for uncharged EnerChip.
- (5) EnerChip charging time and cell resistance increase approximately 2x per 10°C decrease in temperature.

CBC005 EnerChip Discharge Characteristics

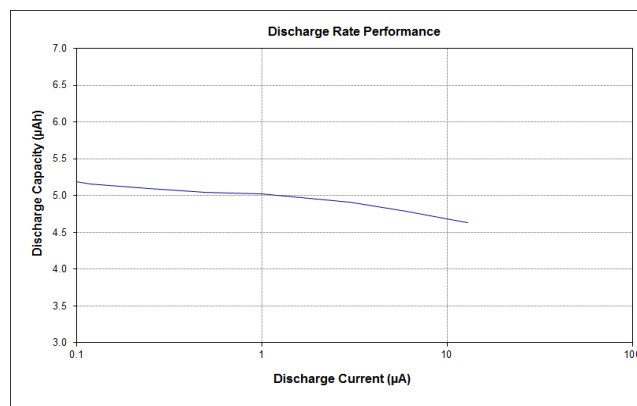
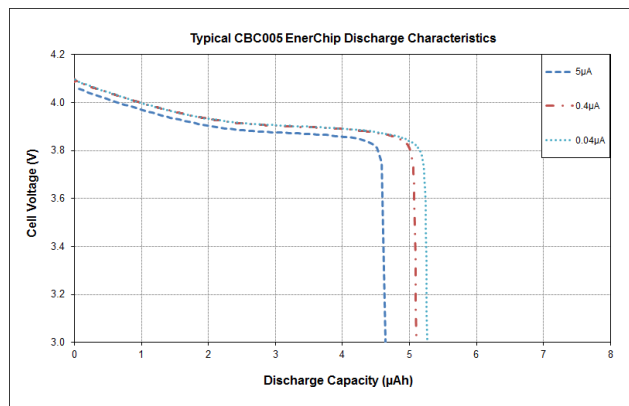

Note: All specifications contained within this document are subject to change without notice.

CBC005 Charging Characteristics

The EnerChip can be recharged quickly. The following graphs illustrate the correlation between charging time and charging current into a discharged cell, and also the cumulative charge vs. charging time. Both graphs are typical based on constant 4.1V charging at room temperature. Charging time increases at lower temperature.

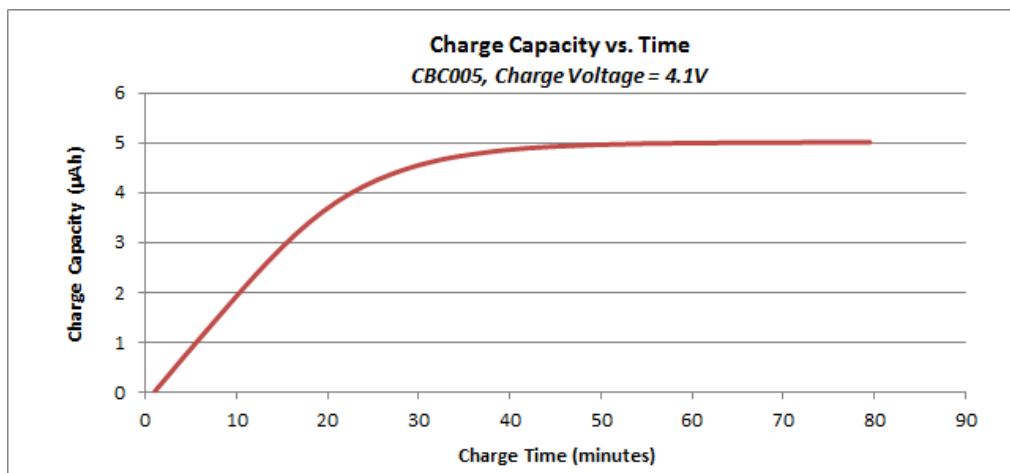
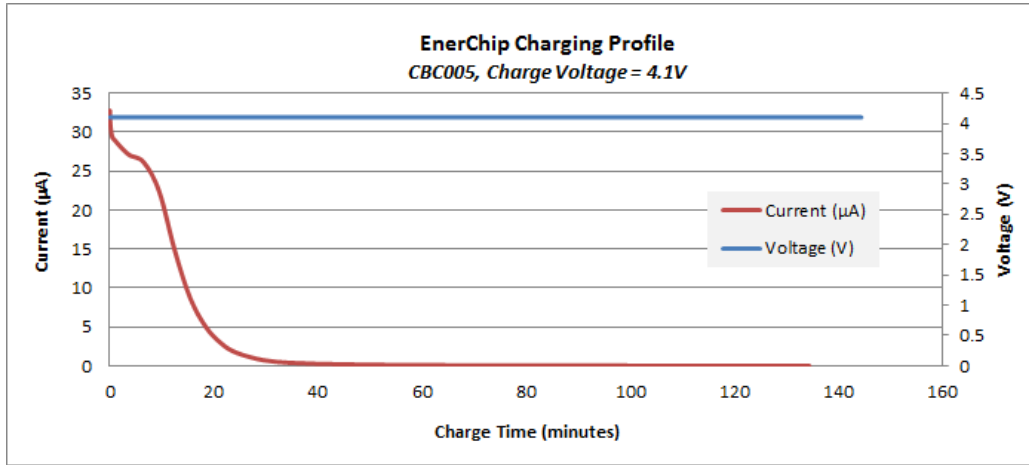

EnerChip Temperature Characteristics

EnerChip cell resistance increases (decreases) with decreasing (increasing) temperature. The following graph represents typical cell resistance over the rated operating temperature range.

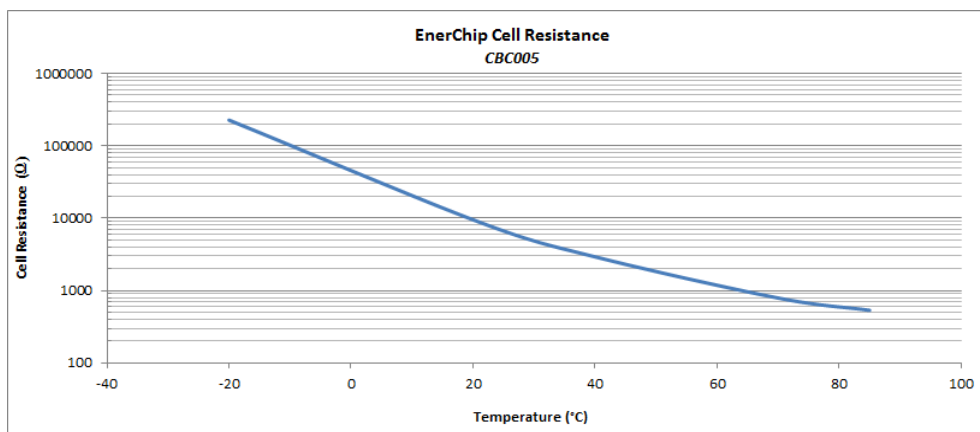

Operating Characteristics - CBC050

| Parameter | | Condition | Min | Typical | Max | Units |
|--|-------|------------------------|-------------------------------|--------------------|--------------------|------------|
| Discharge Cutoff Voltage | | 25 °C | 3.0 ⁽¹⁾ | - | - | V |
| Charge Voltage | | 25 °C | 4.0 ⁽²⁾ | 4.1 | 4.3 | V |
| Pulse Discharge Current | | 25 °C | Variable - see App. Note 1025 | | | - |
| Cell Resistance (25 °C) | | Charge cycle 2 | - | 500 | 1250 | Ω |
| | | Charge cycle 1000 | - | 2250 | 5000 | |
| Self-Discharge (5-yr. average; 25 °C) | | Non-recoverable | - | 2.5 | - | % per year |
| | | Recoverable | - | 1.5 ⁽³⁾ | - | % per year |
| Operating Temperature | | - | -40 | 25 | +70 | °C |
| Storage Temperature | | - | -40 | - | 125 ⁽⁴⁾ | °C |
| Recharge Cycles (to 80% of rated capacity; 4.1V charge voltage) | 25 °C | 10% depth-of-discharge | 5000 | - | - | cycles |
| | | 50% depth-of-discharge | 1000 | - | - | cycles |
| | 40 °C | 10% depth-of-discharge | 2500 | - | - | cycles |
| | | 50% depth-of-discharge | 500 | - | - | cycles |
| Recharge Time (to 80% of rated capacity; 4.1V charge voltage) ⁽⁵⁾ | | Charge cycle 2 | - | 20 | 35 | minutes |
| | | Charge cycle 1000 | - | 60 | 95 | |
| Capacity | | 100µA discharge; 25 °C | 50 | - | - | µAh |

- (1) Failure to cutoff the discharge voltage at 3.0V will result in EnerChip performance degradation.
- (2) Charging at 4.0V will charge the cell to approximately 70% of its rated capacity.
- (3) First month recoverable self-discharge is 5% average.
- (4) Storage temperature is for uncharged EnerChip.
- (5) EnerChip charging time and cell resistance increase approximately 2x per 10°C decrease in temperature.

CBC050 EnerChip Discharge Characteristics

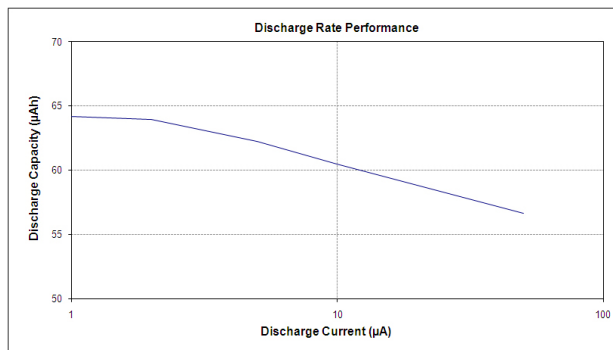
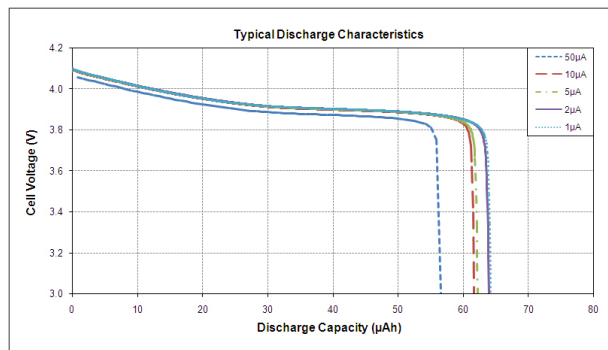

Note: All specifications contained within this document are subject to change without notice.

CBC050 Charging Characteristics

The EnerChip can be recharged quickly. The following graphs illustrate the correlation between charging time and charging current into a discharged cell, and also the cumulative charge vs. charging time. Both graphs are typical based on constant 4.1V charging at room temperature. Charging time increases at lower temperature.

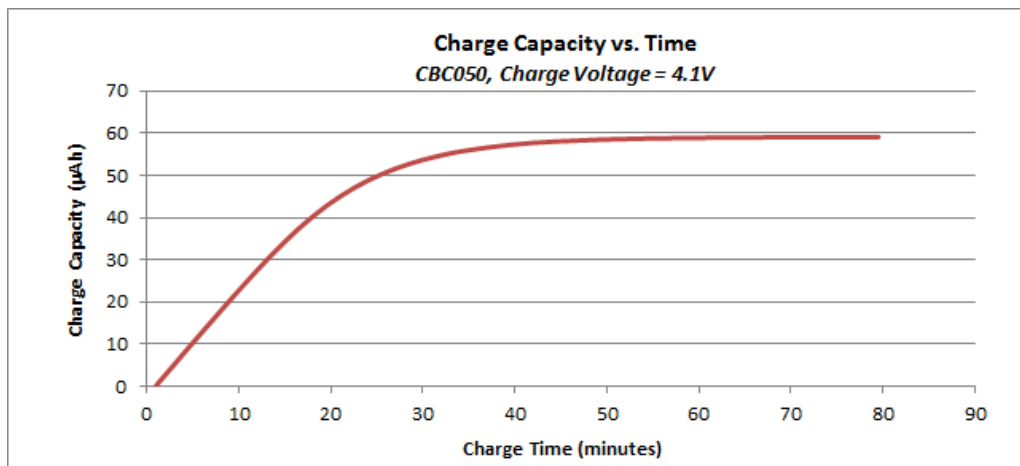
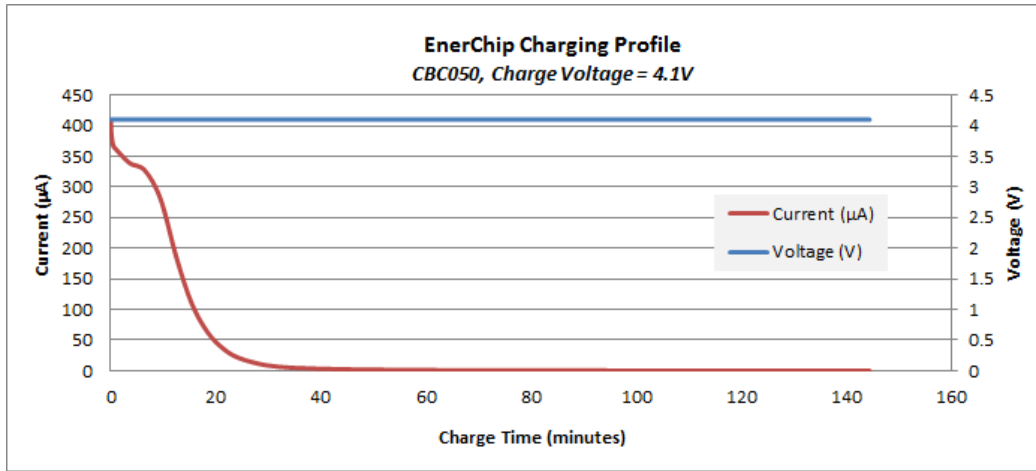

EnerChip Temperature Characteristics

EnerChip cell resistance increases (decreases) with decreasing (increasing) temperature. The following graph represents typical cell resistance over the rated operating temperature range.

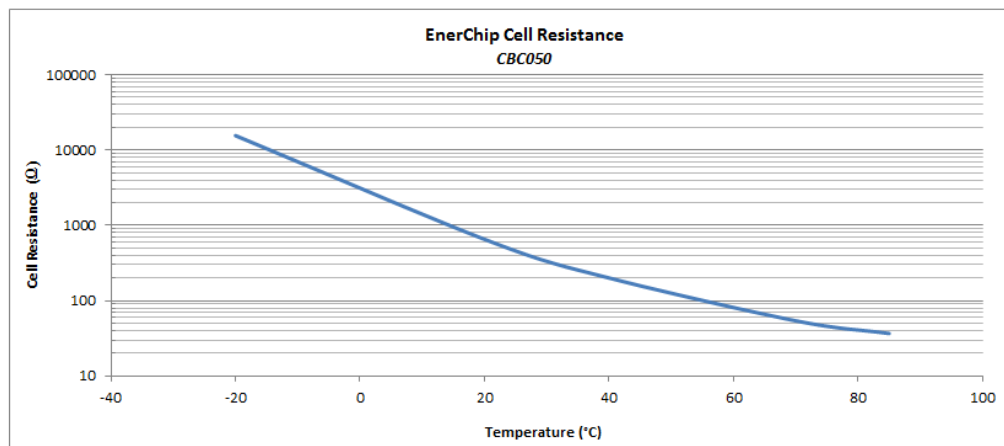

ENERCHIP CHARGING GUIDELINES

As with other rechargeable batteries, discharge capacity and cycle life are a function of charge voltage, discharge cutoff voltage, depth-of-discharge, temperature, and other factors. The system designer must understand the effect of these factors when designing the charge control circuit. Cymbet encourages all designers to utilize the CBC910 Power Management IC (datasheet is DS-72-11) to optimize performance.

- Never charge EnerChip batteries before soldering or exposing to temperatures above the specified operating temperatures. The EnerChip will be damaged or may not work at all.
- Never apply more than 4.3V across the battery terminals as cycle life will be dramatically reduced.
- There is no need to externally limit the charging current of small surface-mount batteries. The intrinsic cell resistance is sufficient to limit the current to an acceptable level as long as the applied voltage does not exceed 4.3V.
- The charging voltage and charge time determine the amount of charge delivered to, and accessible from, the battery. A higher charging voltage will deliver more charge, but will also result in greater long-term capacity fade as a function of charge/discharge cycling. Figure 1 shows trade-offs between charging voltage, charge capacity and cycle fade.
- The batteries may be charged at a constant current (CC) followed by a constant voltage (CV). During the CC phase, the current may be set to any value that results in an acceptable charging time and does not cause the battery voltage to exceed 4.3V.
- CV charging will normally result in faster charging times than the combined CC-CV approach. The latter may become necessary with future, larger batteries with lower intrinsic cell resistance. Please refer to the Operating Characteristics data tables for these batteries.

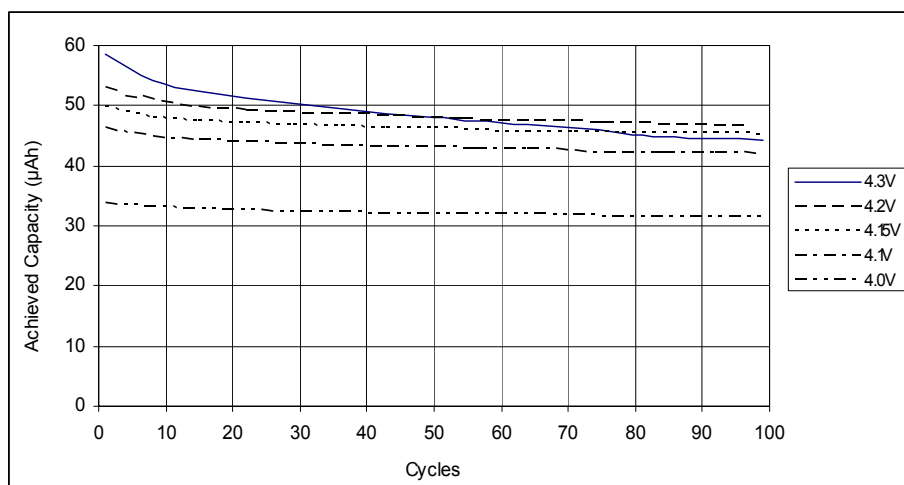

Figure 1: Effect of Charging Voltage on Battery Charge and Cycle Fade

BATTERY PERFORMANCE CONSIDERATIONS

There are several considerations that determine EnerChip performance over time and with use. These are:

Temperature

- Battery aging accelerates with increasing temperature.
- The operating temperature range is narrower than the storage temperature range; moreover, the storage temperature range for an EnerChip that has never been charged is different from that of an EnerChip that has been charged one or more times - partially or fully.
- Battery impedance increases with decreasing temperature - by a factor of approximately 2 for every 10°C reduction in operating temperature.

Number of Charge/Discharge Cycles

- As the depth-of-discharge on the cell increases, the number of charge/discharge cycles decrease.
- The charge/discharge cycle life of the EnerChip is dependent on a number of variables, including temperature, depth-of-discharge, charging voltage, and discharge cutoff voltage. Note that the CBC910 PMIC has built in temperature compensation for battery charging.

Input Charging Conditions

- It is important to regulate the charging voltage applied to the EnerChip in order to ensure a long service life and delivery of the rated capacity.
- Charging at a lower voltage at high temperatures reduces the EnerChip per charge capacity but increased the number of charge/discharge cycles. The CBC910 power management IC performs this function using temperature compensation circuitry.

Discharge Cutoff Conditions

- During discharge of the EnerChip, the minimum discharge cutoff voltage as specified in the data sheet must be enforced. If the discharge voltage is allowed to drop below the rated value, particularly at low discharge currents, the performance of the EnerChip will be degraded, and under certain conditions, the device will ultimately fail to operate according to specifications.
- Regarding resistance to humidity, chemical exposure, and g-forces, the EnerChip product family is designed to meet JEDEC standards.

In-Circuit Use Guidelines

- Do not connect these batteries to other types of batteries except through an approved charging circuit.
- To increase battery life, avoid installing near heat-generating devices.

GUIDELINES FOR HANDLING ENERCHIPS

Certain precautions should be taken when handling and storing EnerChips.

Temperature and Moisture Sensitivity Level

- Store the EnerChip wafers and bare die batteries in waffle packs in their original packaging in an environment where the temperature and humidity do not undergo large fluctuations. Store at 10°C to 30°C and at less than 60% relative humidity.
- Treat EnerChip bare die batteries as you would other MSL-1 devices when handling for assembly.

Electrostatic Discharge (ESD)

- Similar to integrated circuits, the batteries are sensitive to ESD damage prior to receiving a charge cycle. Therefore, adherence to ESD prevention guidelines is required.
- Remove devices from protective shipping and storage containers at approved ESD workstations only.
- All equipment used to process the devices must be configured to minimize the generation of static charges. This includes soldering and de-soldering equipment and tools, pick-and-place equipment, test equipment, and all other tools and equipment used to handle or process the devices.
- Failure to observe these precautions can lead to premature failure and shall void product warranty.

REFLOW SOLDERING

- The maximum number of times the battery may be reflow soldered is three times.
- The surface temperature of the battery must not exceed 240 °C.
- The recommended solder reflow profile is shown in Figure 2 below; refer to Figure 3 Parameters table for time and temperature requirements. Whenever possible, use lower temperature solder reflow profiles.
- Never hand solder or reflow solder an EnerChip battery that has been charged as damage will occur.

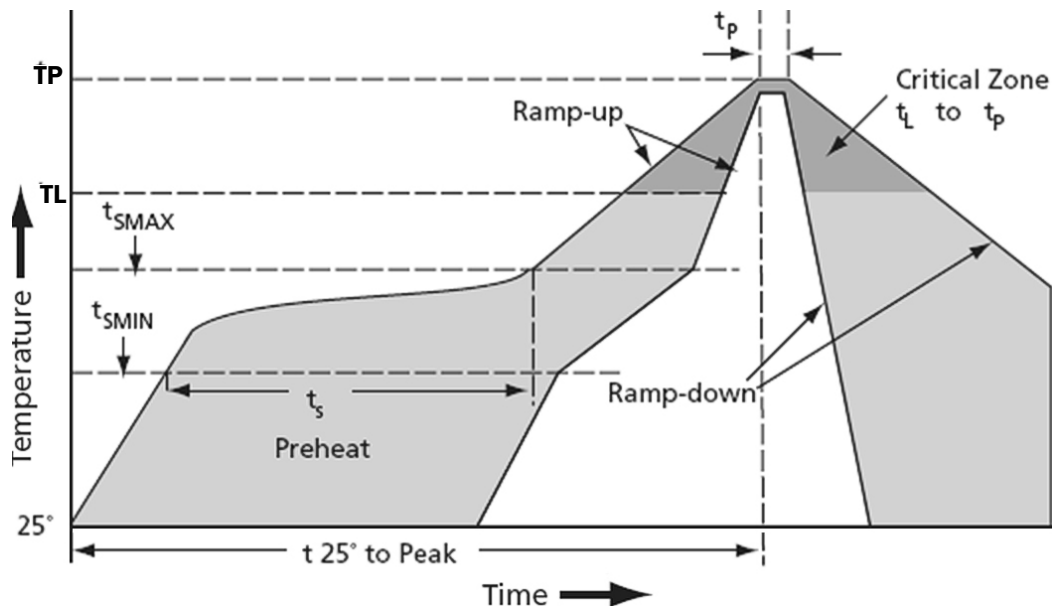

Figure 2: EnerChip Solder Reflow Profile

| Parameter | Sn/Pb | Pb-free |
|------------------------------------|------------|------------|
| Soak temperature, min, TSMIN | 100 °C | 150 °C |
| Soak temperature, max, TSMAX | 150 °C | 200 °C |
| Soak time, max, tS | 2 min | 2 min |
| Max ramp-up rate (TL to TP) | 3 °C/sec | 3 °C/sec |
| Liquidous temperature, TL | 183 °C | 217 °C |
| Time tL maintained above TL | 60-150 sec | 60-150 sec |
| Max peak temperature, TP | 220 °C | 240 °C |
| Max time tP at peak temperature TP | 20 sec | 30 sec |
| Max ramp-down rate (TP to TL) | 6 °C/sec | 6 °C/sec |
| Time 25 °C to peak temperature | 6 min max | 8 min max |

Figure 3: Solder Reflow Parameters as per IPC/JEDEC J-STD-020D.1

BARE DIE DELIVERY OPTIONS

EnerChip bare die applications often require custom procedures and significant variation exists among package vendors and assembly equipment, making specific guidelines difficult. Contact Cymbet Application Engineering to review handling, wirebonding, bumping, and assembly guidelines.

Bare die undergo the following screening procedures prior to leaving the manufacturing facility:

- Electrical test to ensure the cell is not shorted, open, and is within the specification limits of cell resistance.
- MIL-STD-883 optical inspection.

BARE DIE HANDLING GUIDELINES

- When unpacking, storing, inspecting, or handling bare die EnerChips, all operations should be performed in a Class-1,000 (or better) clean room - ISO 6 equivalent.
- When removing die from waffle packs, use the minimum downward force possible with the handling mechanism.
- Handling and insertion forces need to be kept to a minimum to reduce damage to the device materials.
- Tool recommendations: Use pick-and-place tool having a “soft” tip, e.g., rubber or other pliable material.
- EnerChips are sensitive to electrostatic discharge (ESD) and should always be handled in an ESD-controlled environment.
- EnerChips should be stored in a humidity-controlled environment to prevent excess moisture from penetrating the EnerChip.
- Never use tweezers (or other mechanical means) on the film surface of the bare die. When using mechanical means (vs. vacuum pick and place tool) always pick up EnerChip bare by the outside edges of the part.

DIE BUMPING AND WIREBONDING

EnerChip bare die have bond pads that are suitable for either wirebonding. The pad structure on the EnerChip bare die described in this datasheet are designed for wire bonds. With only two bond pads on an EnerChip die, gold stud bumping is not suggested as it would yield a mechanically unsound configuration.

Bond pads are made of aluminum with a small amount of silicon and copper and therefore either gold or aluminum wires may be attached to the bond pad.

Standard wirebond machine and process settings are generally applicable when wirebonding to EnerChip die. When placing EnerChip die onto the die attach material, use the minimum downward force possible. Ensure there is a uniform coating of die attach material on the substrate (i.e., no voids or gaps) and that the die attach material extends to the edge of the EnerChip die during die placement.

Recommended wirebond process time and temperatures are as follows:

Die Attach Epoxy Cure

190 °C +/- 10 °C for 1.5 hours

Wirebond

Pre-heat: 190 °C

Wirebond: 200 °C

Post-heat: 190 °C

Package Epoxy Cure

175 °C +/- 10 °C

BARE DIE TEMPERATURE GUIDELINES

Temperature Guidelines:

- Operating temperature (charged): -40°C to +70°C.
- Storage temperature (uncharged): -40°C to +125°C.
- Bare die assembly process temperatures: Do not exceed +200°C for duration consistent with die attach, wire bond & mold compound cure periods.

BARE DIE ENCAPSULATION AND UNDERFILL GUIDELINES

EnerChip die undergo a minute amount of expansion and contraction when being charged and discharged. Consequently, it is important to not encapsulate the die with overly compressive or rigid materials. Similarly, application of rigid epoxy underfill compounds between a flip-chipped die and printed circuit board material is discouraged.

If applying a protective overcoat on the die, Cymbet recommends either of the following silicone encapsulants, applied at a minimum thickness of 100 microns:

Q1-4939
Q3-6646

Both materials are products from Dow Corning.

Contact Cymbet Applications Engineering to discuss any encapsulation or underfill requirements.

IN-CIRCUIT TESTING OF ENERCHIPS

Once the EnerChip has been assembled in system, it may be charged. If in-circuit testing is to be done for purposes of testing the EnerChip itself or other circuitry on the board, the following guidelines should be observed:

- Never apply a voltage outside the rated charge or discharge voltage range as specified in the respective EnerChip data sheet.
- As with all batteries, the EnerChip has an inherent internal resistance. Never force a current into or out of the EnerChip that would result in the battery voltage rising above or falling below a voltage outside the rated charge or discharge voltage range as specified in the data sheet.
- Once the EnerChip has been charged - partially or fully - do not store or operate the EnerChip outside of the operating temperature range as specified in the data sheet.

Please contact Cymbet Applications Engineering to discuss In-Circuit and System Testing when using EnerChip Bare Die. All customer applications are unique and the EnerChip testing techniques may vary between different end-user products. Please use the Cymbet.com Support Form or call +1-763-633-1780.

CBC005 Bare Die Dimensions

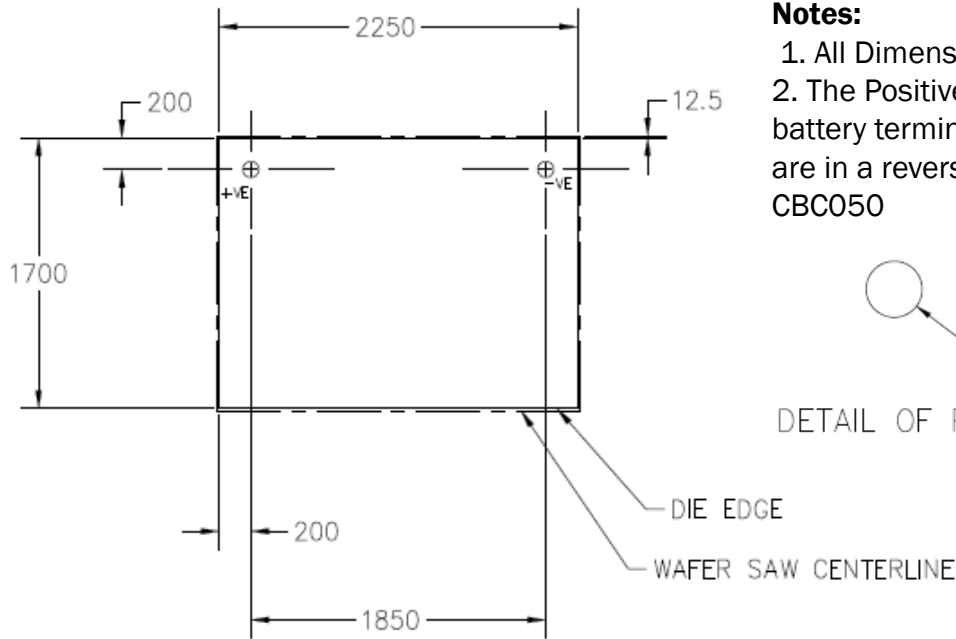

Notes:

1. All Dimensions in Microns
2. The Positive and Negative battery terminals on the CBC005 are in a reversed position from the CBC050

CBC005 Bare Die Anode Pad Cross-Section (Not to Scale)

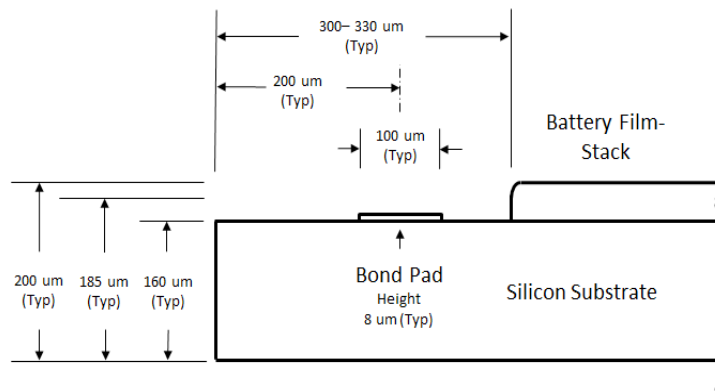

CBC005 Bare Die Cathode Pad Cross-Section (Not to Scale)

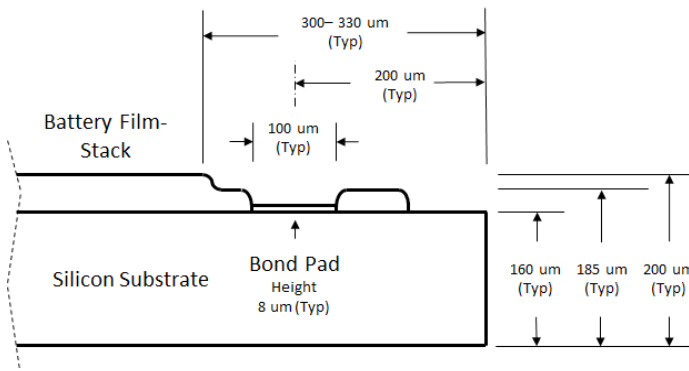

CBC050 Bare Die Dimensions

NOTES:
1. ALL DIMENSIONS IN MICRONS

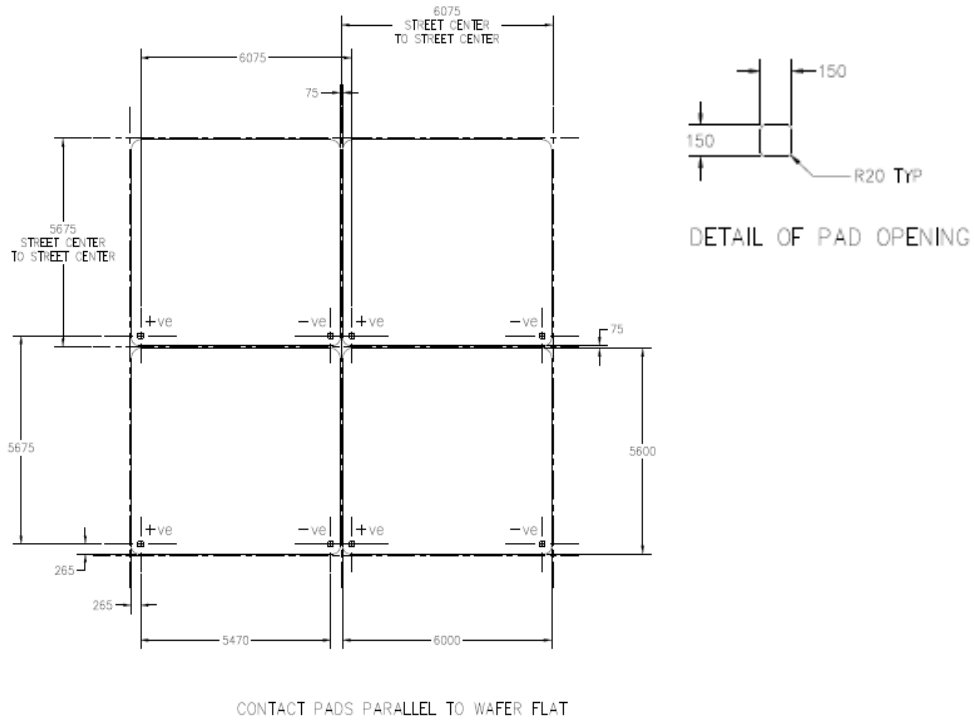

CBC050 Bare Die Anode Pad Cross-Section (Not to Scale)

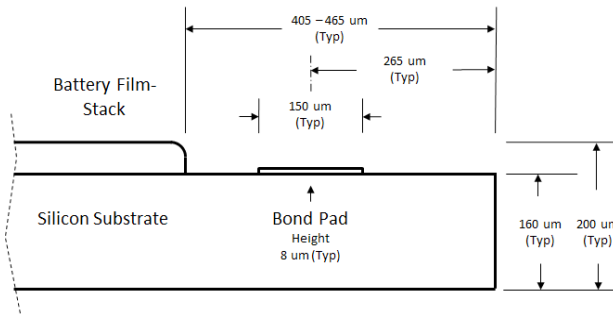

CBC050 Bare Die Cathode Pad Cross-Section (Not to Scale)

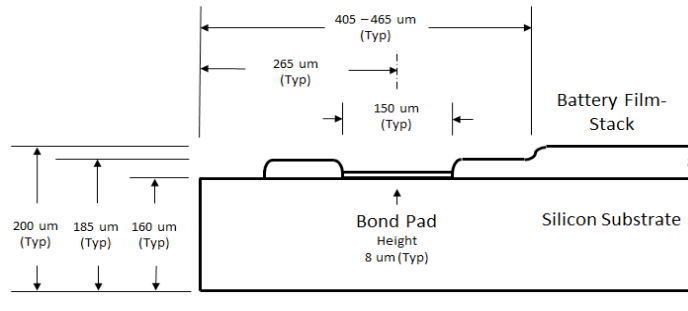

ENERCHIP BARE DIE ASSEMBLY EXAMPLES

The following photos demonstrate how easy it is to use EnerChip bare die batteries in products. The first example in Figure 4 shows the internal construction of the EnerChip RTC device. This device combines a CBC005 5uAh EnerChip bare die battery, a CBC910 Power Management IC, a Real Time Clock bare die, and a capacitor.

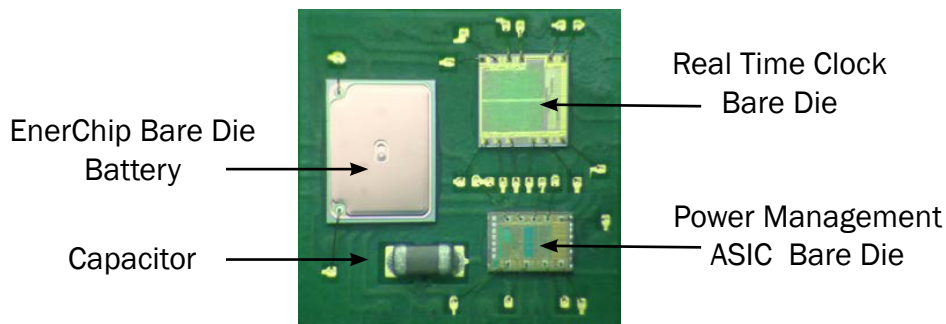

Figure 4: EnerChip RTC multiple bare die in single package

Figure 5 illustrates a three layer EnerChip bare die battery stack using a waterfall wirebond approach.

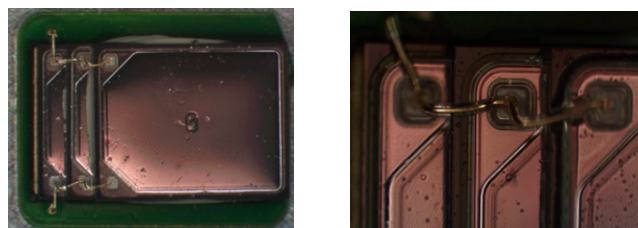

Figure 5: EnerChip bare die battery stack with close-up view

Ordering Information

| EnerChip Part Number | Description | Notes |
|----------------------|--|----------------|
| CBC005-BDC-WP | 5µAh EnerChip Bare Die, Waffle Pack | Contact Cymbet |
| CBC005-BDC-WF | 5µAh EnerChip Bare Die, Wafer for wire bond | Contact Cymbet |
| CBC050-BDC-WP | 50µAh EnerChip Bare Die, Waffle Pack | Contact Cymbet |
| CBC050-BDC-WP | 50µAh EnerChip Bare Die, Wafer for wire bond | Contact Cymbet |

Disclaimer of Warranties; As Is

The information provided in this data sheet is provided "As Is" and Cymbet Corporation disclaims all representations or warranties of any kind, express or implied, relating to this data sheet and the Cymbet EnerChip product described herein, including without limitation, the implied warranties of merchantability, fitness for a particular purpose, non-infringement, title, or any warranties arising out of course of dealing, course of performance, or usage of trade. Cymbet EnerChip products are not authorized for use in life critical applications. Users shall confirm suitability of the Cymbet EnerChip product in any products or applications in which the Cymbet EnerChip product is adopted for use and are solely responsible for all legal, regulatory, and safety-related requirements concerning their products and applications and any use of the Cymbet EnerChip product described herein in any such product or applications.

Cymbet, the Cymbet Logo, and EnerChip are Cymbet Corporation Trademarks