



DESCRIPTION : 150W Wide input AC/DC switching power supply

The rated output power of TPC/PWF-150-XS series is 150W, input voltage range: 85-264VAC, output voltage: 12V, 24V, 27.6V, 48V, High reliability, precision, efficiency, ultra-small size, no external heat sink required, stable output voltage and etc, with short circuit, over-load protection, Widely used in telecommunications, industrial control, instrument, data acquisition, signal control, New Energy, Security, and other electronic systems.

FEATURES

Universal AC input : 85VAC-264VAC	100% full load burn-in test	short circuit, over-load, over-voltage protection
Operating temperature: -20°C~65°C	RoHS complaint	Miniature size, high power density, high efficiency, long life and high reliability
Built-in Active PFC function, PF>0.95	Easy assembling from top side	PCB soldering side with conformal coating

SELECTION GUIDE

Part Number	Input		Output					Efficiency @25°C, (Typ) %	
	Voltage (VAC)		Voltage (VDC)	Pre-set voltage @25°C (V)	Rated current (A)	Current range (A)	Rated power(W)	120VAC input	230VAC input
	Rated	Range							
TPC/PWF-150-12S	220	85-264	12	12.00-12.10	12.5	0-12.5	150	83	86
TPC/PWF-150-24S	220	85-264	24	24.00-24.10	6.3	0-6.3	151.2	83	86
TPC/PWF-150-27.6S	220	85-264	27.6	27.6-27.7	5.4	0-5.4	149.04	83	86
TPC/PWF-150-48S	220	85-264	48	48.00-48.10	3.2	0-3.2	153.6	84	87

All specifications typical at TA=25°C, nominal input voltage and rated output current unless otherwise specified.

OUTPUT CHARACTERISTICS

Conditions	Conditions	Parameter
Ripple and noise, Ta is ambient, 0<Ta≤65°C	12V output voltage	≤100mVp-p
	24V output voltage	≤150mVp-p
	27.6V, 48V output voltage	≤240mVp-p
Ripple and noise, Ta is ambient, -20<Ta≤0°C	12V output voltage	≤200mVp-p
	24V output voltage	≤300mVp-p
	27.6V, 48V output voltage	≤480mVp-p
Dynamic load characteristics, -20<Ta≤65°C	10%-100%: <±10%Vp-p	50%-100%: <±5%Vp-p 10%-50%: <±5%Vp-p
Output adjustment range @25°C	12V output voltage	10.8V-13.2V
	24V output voltage	21.6V-26.4V
	27.6V output voltage	24.8V~30.3V
	48V output voltage	43.2V-52.8V
Voltage regulation accuracy@-20~65°C	±1.0%	
Line regulation@-20~65°C	±0.5%	
Load regulation@-20~65°C	±1.0%	
Temp. coefficient@-20~65°C	±0.03%/°C	
Set-up time@25°C	≤2S (230Vac input, full load), ≤4S (115Vac input, full load)	
Hold-up time@25°C	≥15mS(230Vac input, Full load)	
Overshoot&Undershoot@-20~65°C	<5.0%	

INPUT CHARACTERISTICS

Conditions	Parameter
Input voltage range	85Vac~264Vac
Power factor @25°C	PF>0.98/115VAC & PF>0.95/230VAC (at full load)
Rated input voltage range	100Vac~240Vac
Frequency Range	47Hz~63Hz

INPUT CHARACTERISTICS

Set-up voltage@-20~65℃	90Vac (refer to the derating curve)
Input current@25℃	1.7A@115Vac / 0.8A@230Vac
Inrush current @25℃	≤50A@230Vac Cold start & <30A@115VAC Cold start

PROTECTION @-30~70℃

Conditions	Parameter
Over-power	105%~150% of rated output current, hiccup mode, auto recovery
Over-load	105%~150% of rated output current, hiccup mode, auto recovery
Output short circuit protection	Long-term mode, Auto recovery

ENVIRONMENT CHARACTERISTICS

Conditions	Parameter
Operating amb. Temp.&Humi.	-25℃~65℃; 20%~90%RH No condensing (refer to the derating curve)
Storage Temp. & Humi.	-20℃~85℃; 10%~95%RH No condensing
Vibration	10 ~ 500Hz, 5G 10min./1cycle, period for60min. each along X,Y, Z axes
Pulse	20G/11mS pulse ,3 times at each X,Y,Z axes
Altitude	5000m

SAFETY&EMC STANDARDS @25℃

Conditions	Parameter
Safety Standards	GB4943 / EN60950
Withstand Voltage	I/P-O/P:3.0KVac/10mA; I/P-FG:1.5KVac/10mA; O/P-FG:0.5KVdc/10mA test time:1min.
Grounding test	Test condition: 32A / 2min.; Grounding resistance: <0.1 ohms.
Leakage Current	I/P-Grounding≤3.5mA; I/P-O/P ≤0.25mA 264Vac input 63Hz
Isolation resistance	I/P-O/P: 10M ohms; I/P-FG : 10M ohms; O/P-FG : 10M ohms
EMC emission	EN55032 EN55024, Class B/FCC Part15 Class B
EMC immunity	EN61000-4-2,3,4,5,6,8,11 heavy industry level
Harmaonic current	EN61000-3-2, CLASS D

OTHERS

Conditions	Parameter
Cooling method	Cooling by free air flow
Dimension (L*W*H)	199*99*38mm
Net Weight	0.7kg

RELIABILITY CHARACTERISTICS

Conditions	Parameter
MTBF	200,000Hrs AT 25℃, MIL-217 Method 2 Components Stress Method

MECHANICAL DIMENSIONS

Unit: mm tolerance: +1mm

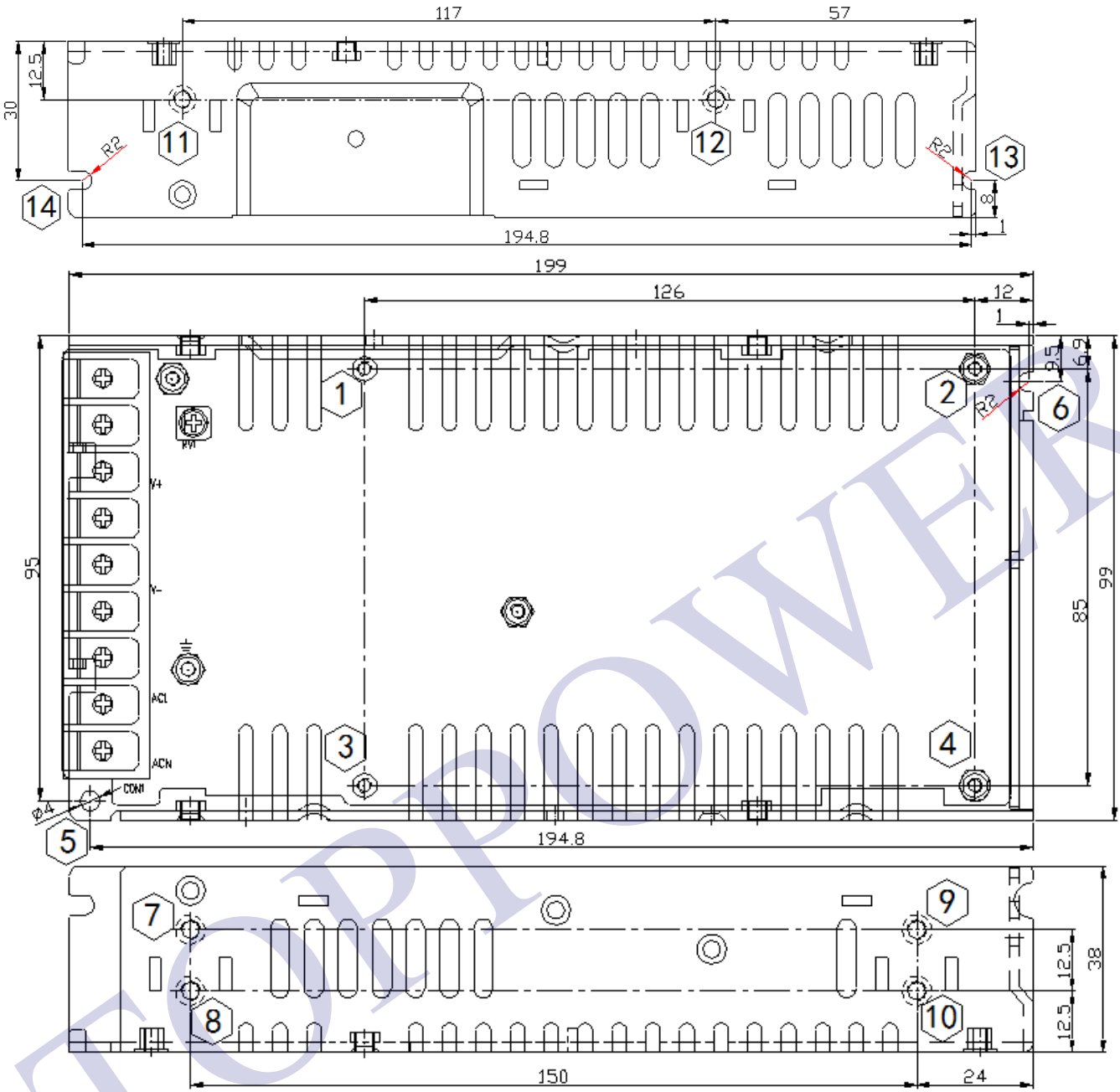

Mounting position No.	Screw Type	L (Max)	Mounting torque(Max)
1 — 4	M3	2.5MM	6.5Kgf. cm
5 — 6	M3	4MM	6.5Kgf. cm
7 — 10 11 — 12	M4	4MM	6.5Kgf. cm
13 — 14	M4	4MM	6.5Kgf. cm

BLOCK DIAGRAM

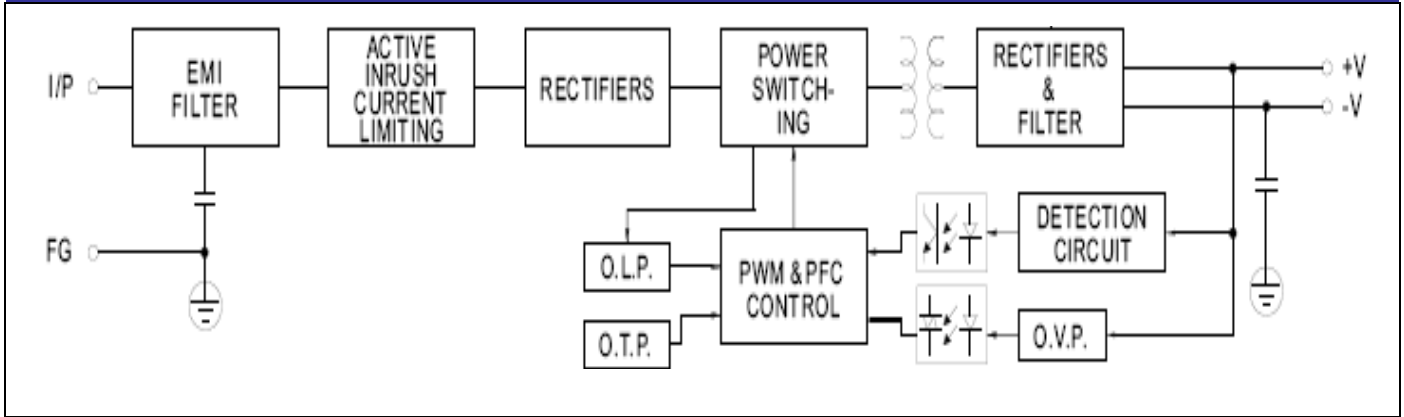

DERATING CURVE

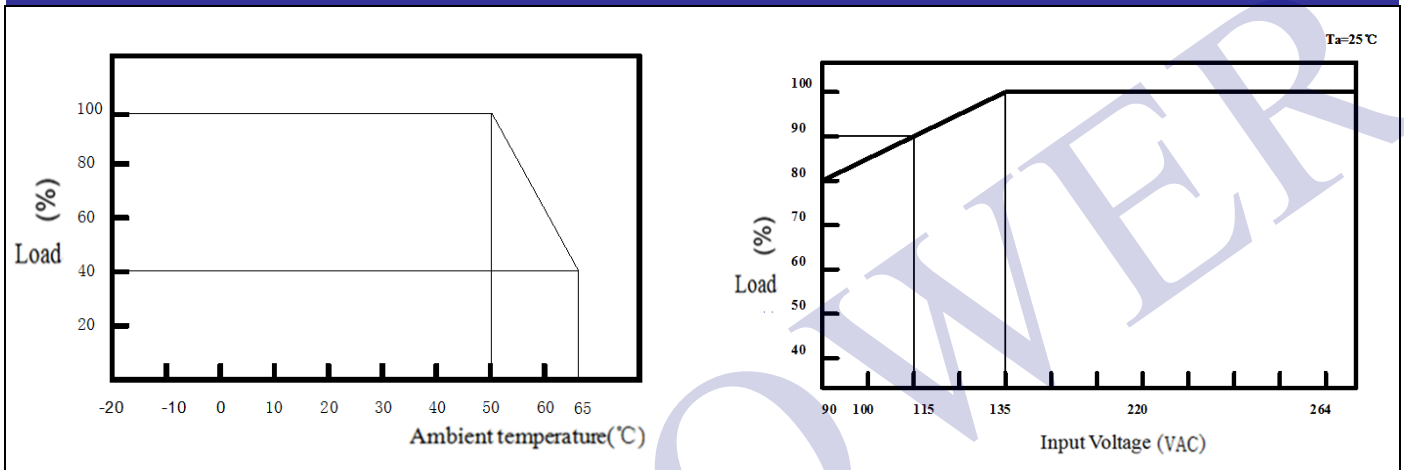

MODEL SELECTION

