



SV7321, SV7358, SV7324

Low Power, Low Noise, 1.2MHz, Rail-to-Rail Input/Output,
General Purpose CMOS Operational Amplifiers

V1.0
SAVITECH Corporation

Low Power, Low Noise, 1.2MHz, Rail-to-Rail Input/Output, General Purpose CMOS Operational Amplifiers

Features

Wide power supply range: +2.1V to +5.5V
 Gain-bandwidth product, GBP (typ.) = 1.2MHz
 Low Noise Voltage Density: 20nV/√Hz
 Very low quiescent current per amplifier: 60μA
 Low input bias current: 1pA
 Low Offset: V_{OS} (typ.) = 1mV, I_{OS} (typ.) = 1pA
 Unity Gain Stable

Description

The SV7321, SV7358 and SV7324 consist of 1/2/4 independent, low power, low noise, internally frequency-compensated CMOS operational amplifiers. It also features wider bandwidth, lower quiescent and lower offset than legacy LMV operational amplifier family. They operate from a single power supply ranging from +2.1V to +5.5V. Operation from split power supplies is also possible and the low power supply current drain is independent of the magnitude of the power supply voltage.

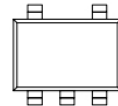

SC70-5

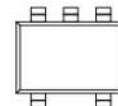

SOT23-5

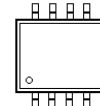

MSOP-8

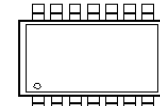

TSSOP-14

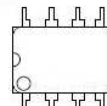

DIP-8

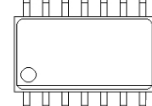

SOP-14

Pin Connection

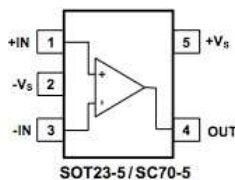

SOT23-5/SC70-5

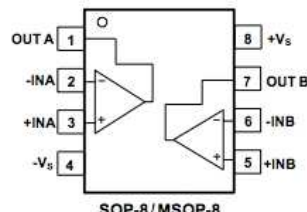

SOP-8/MSOP-8

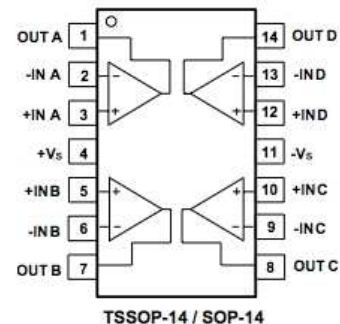

TSSOP-14 / SOP-14

Ordering Information

Part number	Operation range	Package	Packing
SV7321-05OT-TR3	-40°C ~ +85°C	SOT23-5	Tape & Reel, 3000pcs
SV7321-05SC-TR3		SC70-5	Tape & Reel, 3000pcs
SV7324-14SP-TR2		SOP-14	Tape & Reel, 2500pcs
SV7324-14TP-TR2		TSSOP-14	Tape & Reel, 2500pcs
SV7358-08SP-TR2		SOP-8	Tape & Reel, 2500pcs
SV7358-08DP-TR2		DIP-8	Tube, 50pcs
SV7358-08MP-TR3		MSOP-8	Tape & Reel, 3000pcs

Absolute Maximum Ratings

Symbol	Parameter	SV7321	SV7324	SV7358	Unit
V_{CC}	Supply voltage	7.5			V
V_{in}	Input voltage	-0.5 to 7.5			V
	Output short-circuit duration	Infinite			
I_{in}	Input current : V_{in} driven negative Input current : V_{in} driven positive above	5 mA in DC or 50 mA in AC (duty cycle = 10%, T=1s)			mA
T_{oper}	Operating free-air temperature range	-40 to +85			°C
T_{stg}	Storage temperature range	-65 to +150			°C
T_j	Maximum junction temperature	150			°C
R_{thja}	Thermal resistance junction to ambient SOP-14 MSOP-8 SOT23-5	103 216 190			°C/W
ESD	HBM: human body mode	8K			V
	MM: machine mode	400			

NOTE: Stresses above those listed under Absolute Maximum Ratings may cause permanent damage to the device. This is a stress rating only; functional operation of the device at these or any other conditions above those indicated in the operational section of this specification is not implied. Exposure to absolute maximum rating conditions for extended periods may affect device reliability.

CAUTION

This integrated circuit can be damaged by ESD if you don't pay attention to ESD protection. SAVITECH recommends that all integrated circuits be handled with appropriate precautions. Failure to observe proper handling and installation procedures can cause damage. ESD damage can range from subtle performance degradation to complete device failure. Precision integrated circuits may be more susceptible to damage because very small parametric changes could cause the device not to meet its published specifications.

Electrical Characteristics

Vs = +5V, TA = +25°C, VCM = Vs/2, RL = 600 , unless otherwise noted						
PARAMETER	CONDITION	TYP	MIN/MAX OVER TEMPERATURE			
		+25°C	+25°C	-40°C to 85°C	UNITS	MIN/MAX
INPUT CHARACTERISTICS						
Input Offset Voltage (V _{OS})		1	3	3.7	mV	MAX
Input Bias Current (I _B)		1			pA	TYP
Input Offset Current (I _{OS})		1			pA	TYP
Common-Mode Voltage Range (V _{CM})	V _S = 5.5V	-0.1 to +5.6			V	TYP
Common-Mode Rejection Ratio (CMRR)	V _S = 5.5V, V _{CM} = -0.1V to 4V	91	75	73	dB	MIN
	V _S = 5.5V, V _{CM} = -0.1V to 5.6V	86	64	63	dB	MIN
Open-Loop Voltage Gain (A _{OL})	R _L = 600 , V _O = 0.15V to 4.85V	80	70		dB	MIN
	R _L = 10k , V _O = 0.05V to 4.95V	85	75		dB	MIN
Input Offset Voltage Drift (V _{OS} / T)		2.1			V/°C	TYP
OUTPUT CHARACTERISTICS						
Output Voltage Swing from Rail	R _L = 600	0.1			V	TYP
	R _L = 100k	0.015			V	TYP
Output Current (I _{OUT})		25	20	18	mA	MIN
POWER SUPPLY						
Operating Voltage Range			2.1	2.1	V	MIN
			5.5	5.5	V	MAX
Power Supply Rejection Ratio (PSRR)	V _S = +2.5V to +5.5V V _{CM} = (-V _S) + 0.5V	80	70	78	dB	MIN
Quiescent Current/ Amplifier (I _Q)	I _{OUT} = 0	60	85		uA	MAX
DYNAMIC PERFORMANCE						
Gain-Bandwidth Product (GBP)	R _L = 600	1.2			MHz	TYP
Phase Margin (φ)		63.5			degree	TYP
Full Power Bandwidth (BW _p)	< 1% distortion	400			kHz	TYP
Slew Rate (SR)	G = +1, 2V Output Step	0.38			V/ s	TYP
Settling Time to 0.1% (t _s)	G = +1, 2V Output Step	0.36			s	TYP
Overload Recovery Time	V _{in} Gain = V _s	0.4			s	TYP
NOISE PERFORMANCE						
Voltage Noise Density	f = 1kHz	20			nV/√Hz	TYP
	f = 10kHz	14			nV/√Hz	TYP

Output Voltage vs. Output Current Source Sweep

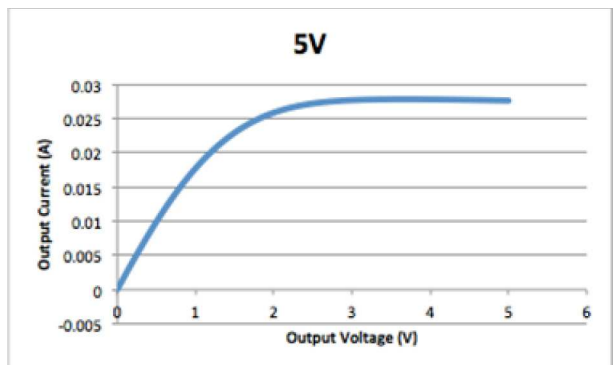
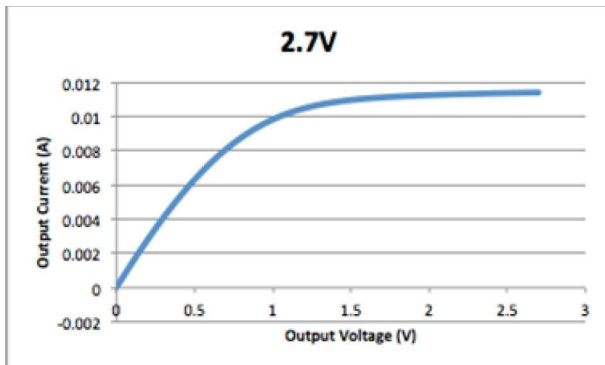

Output Voltage vs. Output Current Sink Sweep

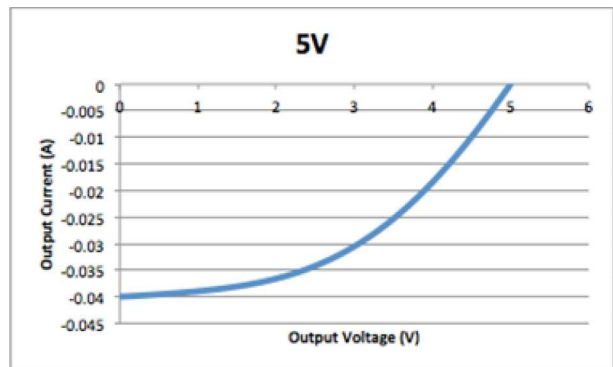
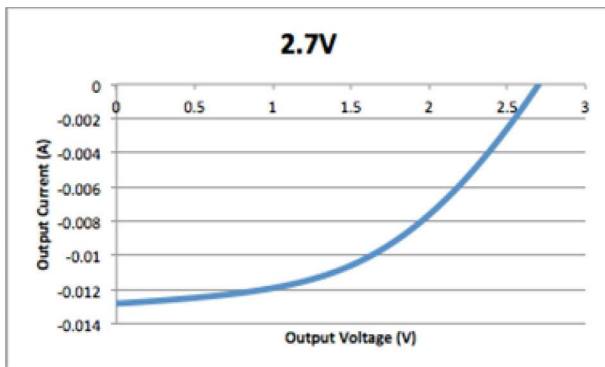

Rail Output

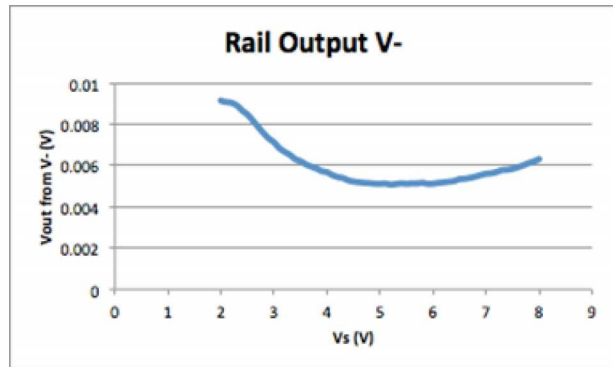
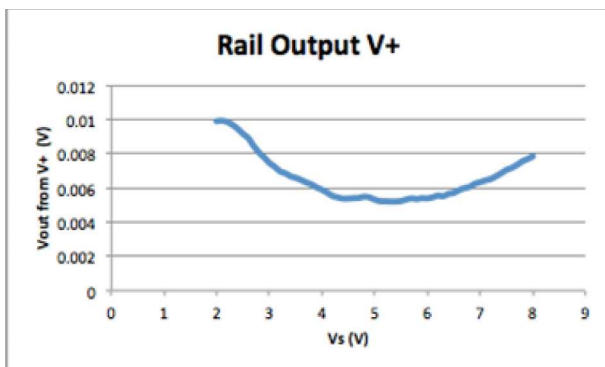

CMRR vs. Frequency

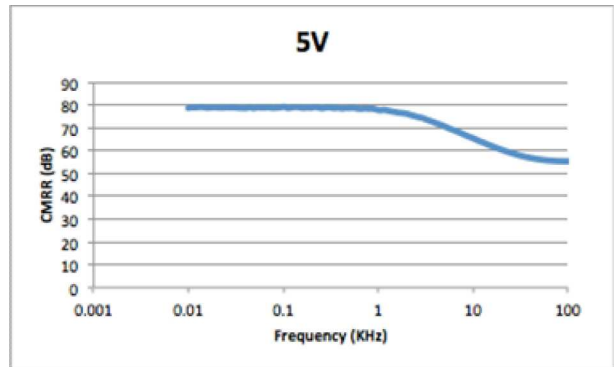
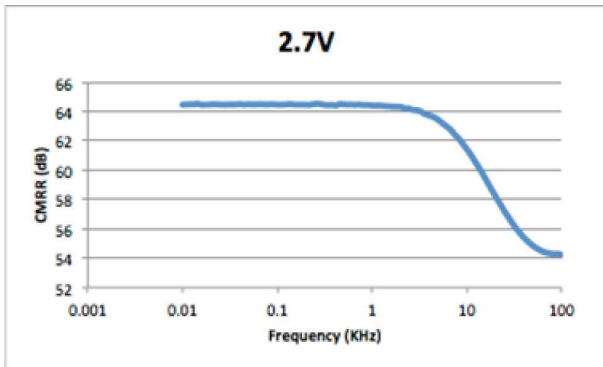

I_Q Current vs. V_{cc}

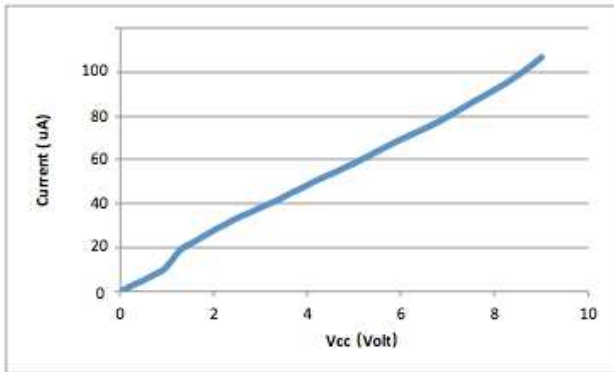

Input Noise vs. Frequency

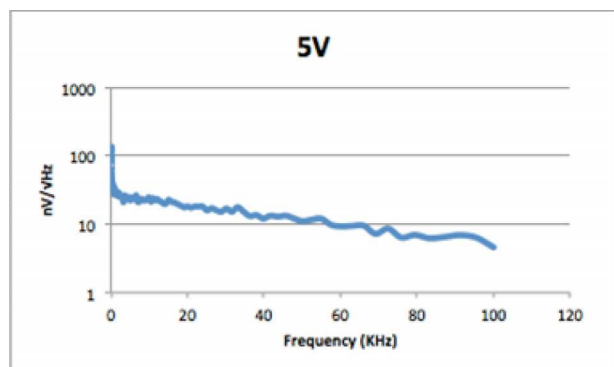
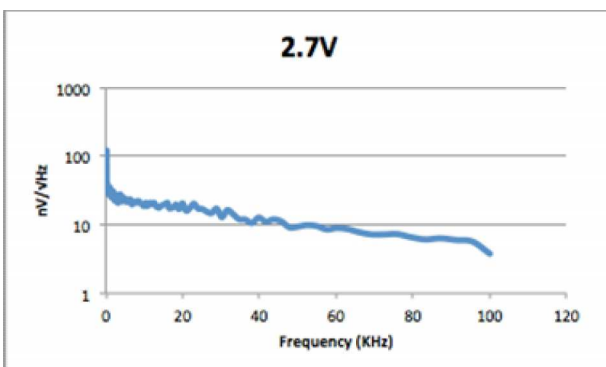

PSRR vs. Frequency

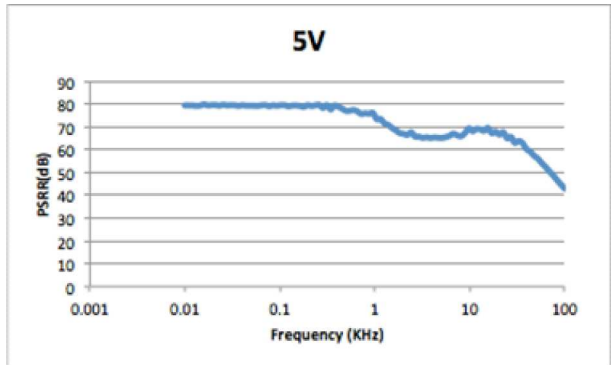
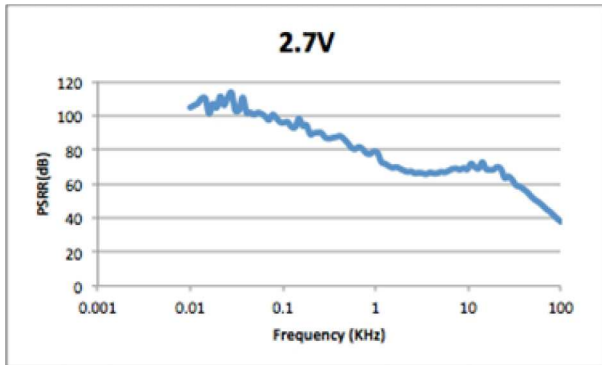

SOT23-5 MECHANICAL DATA

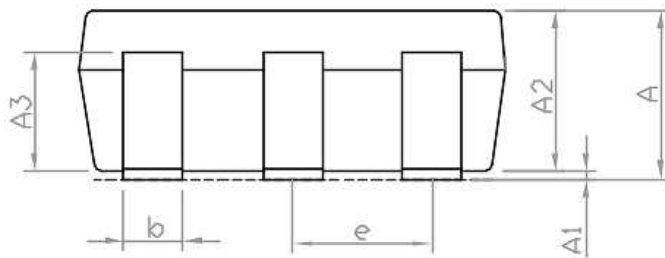
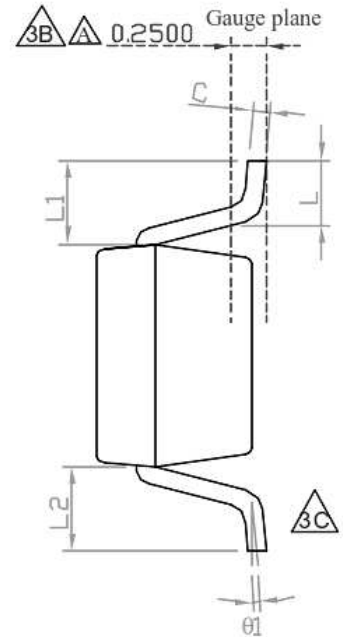
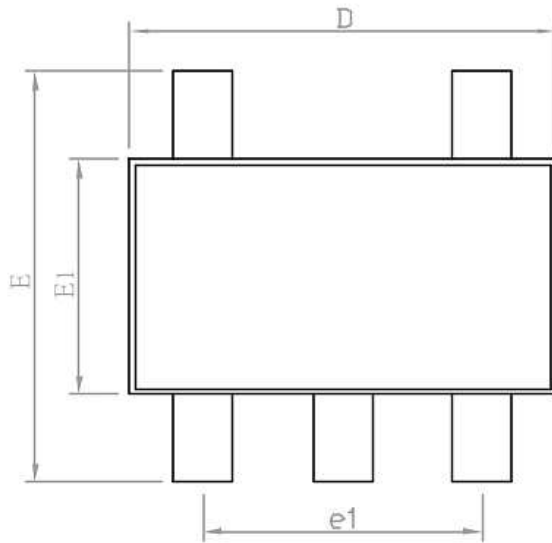

SYMBOLS	DIMENSIONS IN MILLIMETERS		
	MIN	NOM	MAX
$\Delta 3A$ A	1.00	1.10	1.40
A1	0.00	0.05	0.10
A2	1.00	1.10	1.30
A3	0.70	0.80	0.90
b	0.35	0.40	0.50
$\Delta 3A$ C	0.12	0.125	0.225
D	2.70	2.90	3.10
E	2.60	2.80	3.00
E1	1.40	1.60	1.80
e	----	0.95(TYP)	----
e1	----	1.90(TYP)	----
θ_1	1°	5°	9°
L	0.37	----	----
$\Delta 3A$ L1	----	0.6REF	----
$\Delta 3A$ L1-L2	----	----	0.12

NOTE

1. PACKAGE BODY SIZES EXCLUDE MOLD FLASH PROTRUSIONS OR GATE BURRS
2. TOLERANCE ± 0.1000 mm (4 mil) UNLESS OTHERWISE SPECIFIED
3. COPLANARITY : 0.1000 mm
4. DIMENSION L IS MEASURED IN GAUGE PLANE

SOP-14 MECHANICAL DATA

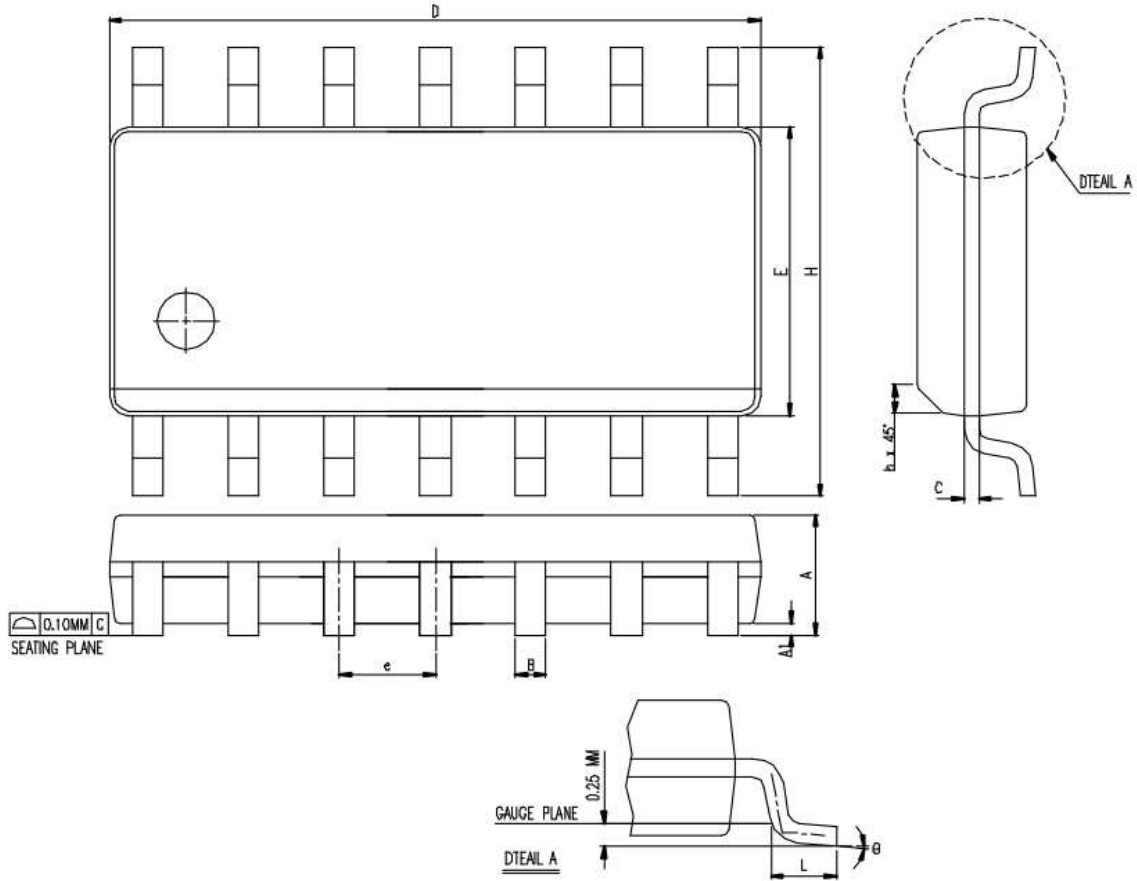

Symbol	Dimension in MM		Dimension in Inch	
	Min.	Max.	Min.	Max.
A	1.35	1.75	0.0532	0.0688
A1	0.10	0.25	0.004	0.0098
B	0.33	0.51	0.013	0.02
C	0.19	0.25	0.0075	0.0098
e	1.27BSC		0.050 BSC	
D	8.55	8.75	0.3367	
H	5.80	6.20	0.2284	0.344
E	3.80	4.00	0.1497	0.244
L	0.40	1.27	0.016	0.1574
h	0.25	0.50	0.0099	0.0196
Θ	0*	8*	0*	8*
JEDEC	MS-012 (AB)			

***Notes:**

Dimension "D" does not include mold flash, Protrusions or gate burrs.
 Mold flash, protrusions and gate burrs shall not exceed 0.15 MM (0.006 Inch) per side.

MSOP-8 MECHANICAL DATA

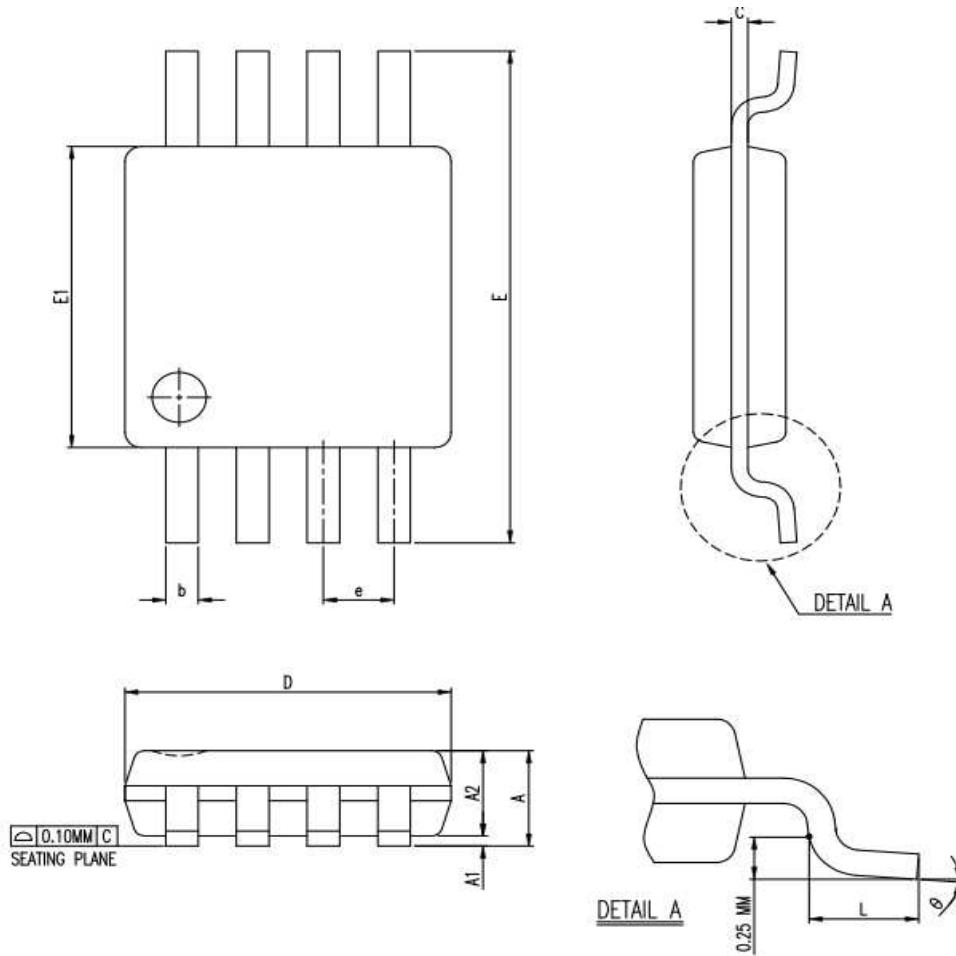

Symbol	Dimension in MM			Dimension in Inch		
	Min.	Mon.	Max.	Min.	Mon.	Max.
A	0.81	1.02	1.10	0.032	0.040	0.043
A1	0.05		0.15	0.002		0.006
B	0.76	0.86	0.95	0.030	0.034	0.037
C	0.28	0.30	0.38	0.011	0.012	0.015
E	0.13	0.15	0.23	0.005	0.006	0.009
E	0.29	3.00	3.10	0.114	0.118	0.122
E1	4.75	4.90	5.05	0.187	0.193	0.199
E	2.90	3.00	3.10	0.114	0.118	0.122
E	0.65 BASIC			0.026 BASIC		
L	0.40	0.55	0.70	0.016	0.022	0.028
Θ	0*	3*	6*	0*	3*	6*
JEDEC	MS-012 (AB)					

***Notes:**

Dimension "D" does not include mold protrusions or gate burrs.
 Mold protrusions and gate burrs shall not exceed 0.15 MM (0.006 Inch) per side.
 Dimension "E1" does not include mold protrusions. Mold protrusions shall not exceed 0.25 MM (0.010 Inch) per side.

SOP-8 MECHANICAL DATA

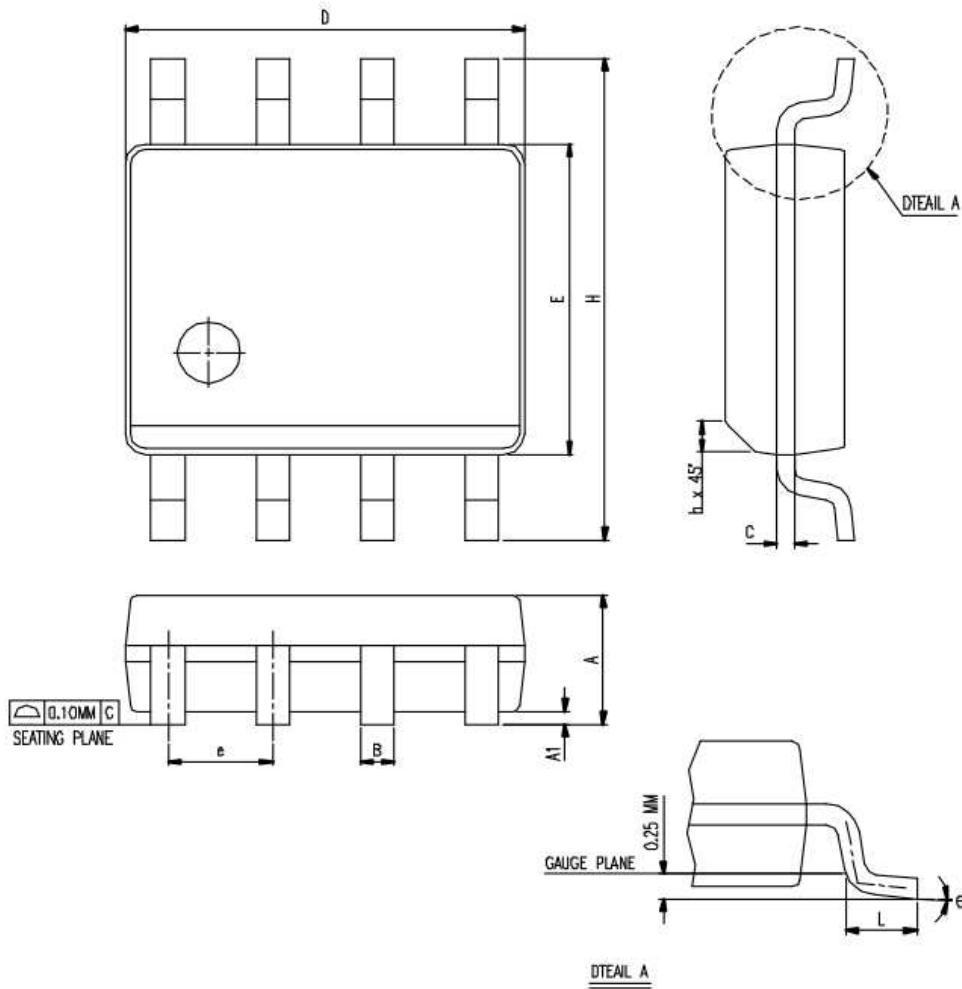

Symbol	Dimension in MM		Dimension in Inch	
	Min.	Max.	Min.	Max.
A	1.35	1.75	0.0532	0.0688
A1	0.10	0.25	0.004	0.0098
B	0.33	0.51	0.013	0.02
C	0.19	0.25	0.0075	0.0098
e	1.27BSC		0.050 BSC	
D	4.80	5.00	0.1890	0.1968
H	5.80	6.20	0.2284	0.2440
E	3.80	4.00	0.1497	0.1574
L	0.40	1.27	0.016	0.050
h	0.25	0.50	0.0099	0.0196
⌀	0*	8*	0*	8*
JEDEC	MS-012 (AA)			

***Notes:**

Dimension "D" does not include mold flash, Protrusions or gate burrs.
 Mold flash, protrusions and gate burrs shall not exceed 0.15 MM (0.006 Inch) per side.

Information furnished is believed to be accurate and reliable. However, SAVITECH assumes no responsibility for the consequences of use of such information nor for any infringement of patents or other rights of third parties that may result from its use. No license is granted by implication or otherwise under any patent or patent rights of SAVITECH. Specifications mentioned in this publication are subject to change without notice. This publication supersedes and replaces all information previously supplied. SAVITECH products are not authorized for use as critical components in life support devices or systems without express written approval of SAVITECH.

The SAVITECH logo is a registered trademark of Savitech Corporation.

All other names are the property of their respective owners

© 2011 Savitech Corporation - All Rights Reserved