

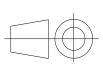

CRIMP DATA (TE TERMINAL)					
TERMINAL NAME	RING TONGUE. 25 SQ MM / M8 - INTERCABLE				
CRIMP	SIZE	TYPE		RANGE	
WIRE	COROPLAST			25 mm ²	
INSUL					
WIRE STRIP LENGHT	10.5 ±0.5		APPLICATOR INSTRUCTION		
TERMINAL APPL SPEC		PRODUCT SPECIFICATION		FEED	
TERMINALS APPLIED			SEALS		
2177380-1	-	-	-	-	-
-	-	-	-	-	-
-	-	-	-	-	-
-	-	-	-	-	-
-	-	-	-	-	-
-	-	-	-	-	-
WIRE SIZE (mm ² AWG)		CRIMP HEIGHT		REF SETTING	
25 mm ²		4.35 ±0.1			
-		-		-	
-		-		-	
-		-		-	
-		-		-	
-		-		-	
-		-		-	
-		-		-	
REMARK: Applicator only used in combination with COROPLAST (LV216-2) Application Spec. VW TAB 016.358.AC					
TYPE: Applicator for LP-Terminals					
TERMINATOR: HV CRIMPING MACHINE 528008-4					

P	LTR	REVISION RECORD	DATE	DWN	APVD	PRINTED	DWN	09MAR12	CHK	APVD
-	B	SEE SHEET 1	-	-	-	07MAY13	R. GERMANN	-	-	-
-	C	SEE SHEET 1	-	-	-	WEIGHT	DIMENSION (mm)	MATERIAL	HT TR	
-	C1	SEE SHEET 1	-	-	-	-	-	-	-	-
-	D	SEE SHEET 1	-	-	-	 TOLERANCES UNLESS OTHERWISE SPECIFIED SEE SHEET 1		 tyco Electronics AMP GmbH D-64625 Bensheim SPARE AND WEAR PARTS LIST		
THIS DRAWING IS A CONTROLLED DOCUMENT FOR TYCO ELECTRONICS CORPORATION. IT IS SUBJECT TO CHANGE AND THE CONTROLLING ENGINEERING ORGANIZATION SHOULD BE CONTACTED FOR THE LATEST REVISION. DIESES ZEICHNUNGSDOKUMENT WIRD DURCH TYCO ELECTRONICS CORPORATION KONTROLLIERT. ÄNDERUNGEN DIE DEM TECHNISCHEN FORTSCHRITT DIENEN, SIND VORBEHALTEN. DEN JEWEILS LETZTGÜLTIGEN ÄNDERUNGSSTAND ERFAHREN SIE AUF ANFRAGE						NAME DIE SET IPT-VW WIRE CRIMP 25 SQMM				RESTRICTED TO
SCALE		SIZE	DRAWING NO		SHEET	REV				
SEE SHEET 1		A4	C-528041-3		1 / 3	D				

THIS DRAWING IS UNPUBLISHED. RELEASED FOR PUBLICATION 2012
 © COPYRIGHT 2012 Tyco Electronics AMP GmbH ALL RIGHTS RESERVED.

LOC	DIST	REVISIONS			
P	LTR	DESCRIPTION	DATE	DWN	APVD
AI	-				
		C	Initial release	06JUN2012	RG GS
		D	ECR-13-007573	07MAY2013	BM GS

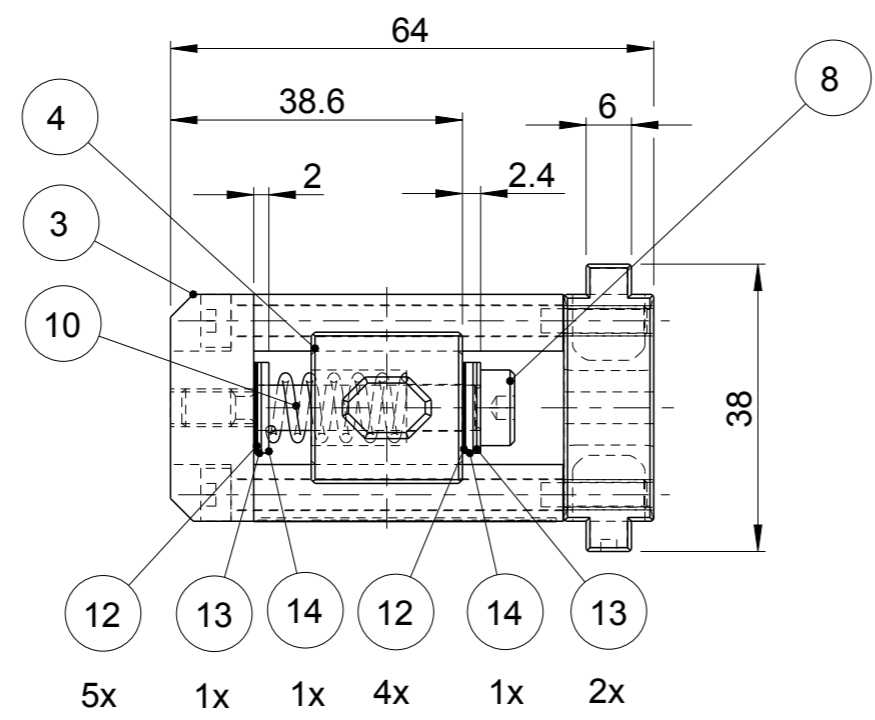
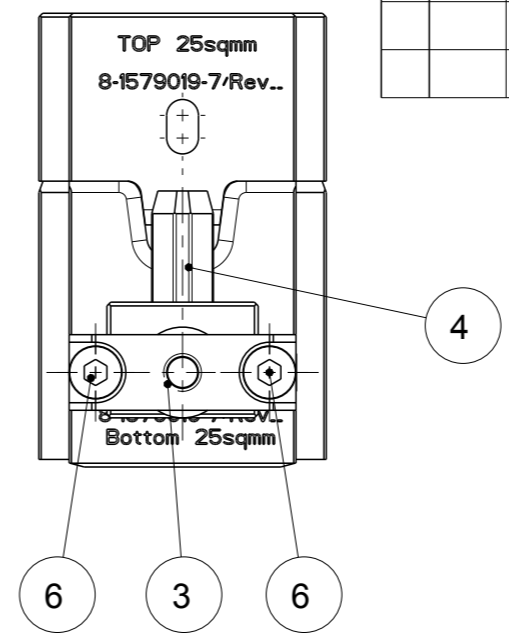
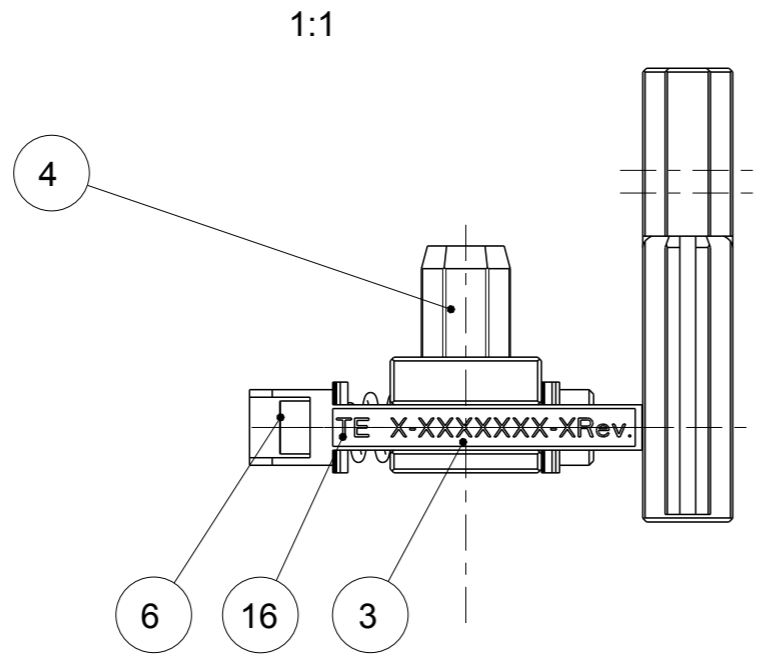
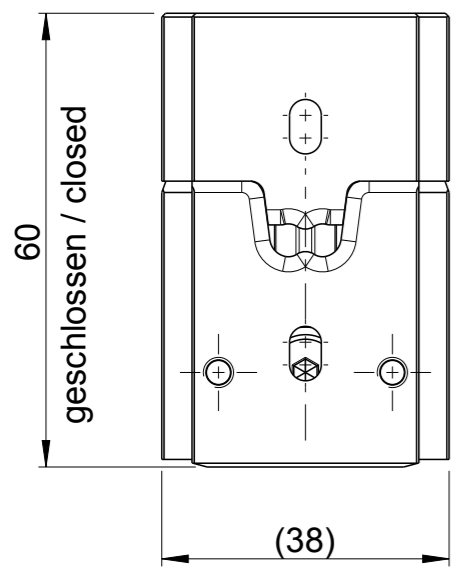

Anwendungsbereich / Application range

For Tubular Cable lug 8-25mm²-Sn
 Intercable-Art.-Nr. 380078

Einsatz nur in / Only in combination with

HV-Crimpmaschine / HV-Crimpmachine □	mit AT66 DIE-SET ADAPTER, HV / with AT66 DIE-SET ADAPTER, HV
P/N 528008-4	P/N 541868-1
P/N 528008-3 und P/N 528008-5	P/N 541868-2

THIS DRAWING IS A CONTROLLED DOCUMENT		DWN 06JUN2012 R. Germann	TE TE Connectivity
		CHK 06JUN2012 G. Stegmayer	
DIMENSIONS: mm	TOLERANCES UNLESS OTHERWISE SPECIFIED:	APVD -	NAME DIE SET IPT-VW WIRE CRIMP 25 SQMM MATRIZE IPT-VW DRAHTCRIMP 25 qmm
	0 PLC ±-	PRODUCT SPEC -	SIZE CAGE CODE DRAWING NO
	1 PLC ±-	APPLICATION SPEC -	A3 00779 C-528041-3
	2 PLC ±-	WEIGHT -	RESTRICTED TO
	3 PLC ±-		
	4 PLC ±-		
	ANGLES ±1°		
MATERIAL -	FINISH -		
CUSTOMER DRAWING		SCALE 1:1	SHEET 3 OF 3 REV D