



FC3255 1.5A PWM Switching Regulators

Description

3255 products are 280 kHz switching regulators with a high efficiency, 1.5 A integrated switch. These parts operate over a wide input voltage range, from 2.7 V to 30 V. The flexibility of the design allows the chips to operate in most power supply configurations, including boost, flyback, forward, inverting, and SEPIC. The ICs utilize current mode architecture, which allows excellent load and line regulation, as well as a practical means for limiting current. Combining high frequency operation with a highly integrated regulator circuit results in an extremely compact power supply solution. The circuit design includes provisions for features such as frequency synchronization, shut-down, and feedback controls for either positive or negative voltage regulation.

Features

- ◆ **Integrated Power Switch: 1.5 A Guaranteed**
- ◆ **Input Voltage Range: 2.7 V to 30 V**
- ◆ **High Frequency Allows for Small Components**
- ◆ **Minimum External Components**
- ◆ **Easy External Synchronization**
- ◆ **Built in Overcurrent Protection**
- ◆ **Frequency Foldback Reduces Component Stress During an Overcurrent Condition**
- ◆ **Thermal Shutdown with Hysteresis**
- ◆ **Regulates Either Positive or Negative Output Voltages**
- ◆ **Shut Down Current: 50 μ A Maximum**
- ◆ **Wide Temperature Range Commercial Commercial Grade : 0 to 70°C (3255)**

Application

Boost Regulators

CCFL Backlight Driver

Laptop Computer Supplies

Multiple Output Flyback Supplies

Inverting Supplies

TFT LCD Bias Supplies

TYPICAL APPLICATION CIRCUITS

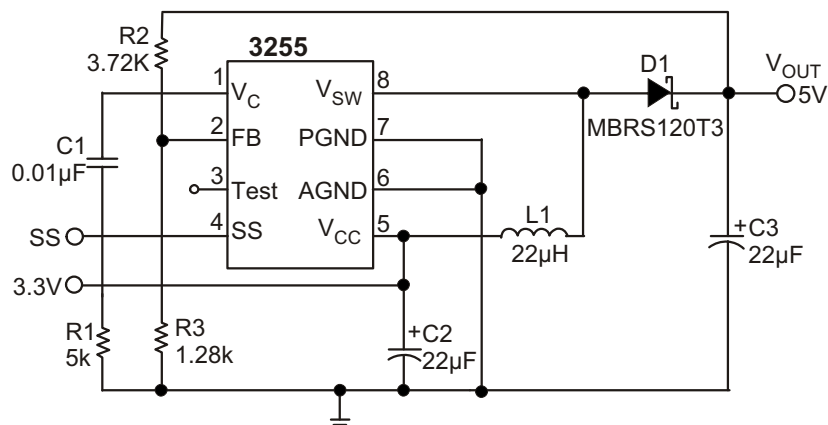



FC3255 1.5A PWM Switching Regulators

◆ MARKING INFORMATION & PIN CONFIGURATIONS (TOP VIEW) SOP-8

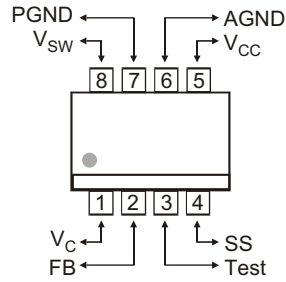

Ordering Number	Package	Shipping
3255S8T	SOP - 8	100 Units / Tube
3255S8R	SOP - 8	2,500 Units / Tape & Reel

* For detail Ordering Number identification, please see last page.

◆ PIN DESCRIPTION

PIN NUMBER	PIN SYMBOL	FUNCTION
1	V_C	Loop compensation pin. The V_C pin is the output of the error amplifier and is used for loop compensation, current limit and start. Loop compensation can be implemented by a simple RC network as shown in the application diagram on page 2 as R1 and C1.
2	FB	Positive regulator feedback pin. This pin senses a positive output voltage and is referenced to 1.276V. When the voltage at this pin falls below 0.4 V, chip switching frequency reduces to 20% of the nominal frequency.
3	Test	These pins are connected to internal test logic and should either be left floating or tied to ground. Connection to a voltage between 9.5V and 15V shuts down the internal oscillator and leaves the power switch running.
4	SS	Synchronization and shutdown pin. This pin may be used to synchronize the part to nearly twice the base frequency. ATTL low shut the part down and put it into low current mode. If synchronization is not used, this pin should be either tied high or left floating for normal operation.
5	V_{CC}	Input power supply pin. This pin supplies power to the part and should have a bypass capacitor connected to AGND.
6	AGND	Analog ground. This pin provides a clean ground for the controller circuitry and should not be in the path of large currents. The output voltage sensing resistors should be connected to the IC substrate.
7	PGND	Power ground. This pin is the ground connection for the emitter of the power switching transistor. Connection to a good ground plane is essential.
8	V_{SW}	High current switch pin. This pin connects internally to the collector of the power switch. The open voltage across the power switch can be as high as 40V. To minimize radiation, use a trace as short as practical.

◆ ABSOLUTE MAXIMUM RATINGS

PARAMETER	VALUE	UNITS
Package Thermal Resistance Junction-to-Case, R_{JC} Junction-to-Ambient, R_{JA}	45 165	$^{\circ}\text{C} / \text{W}$ $^{\circ}\text{C} / \text{W}$
Junction Temperature Range, T_J	-40 to +150	$^{\circ}\text{C}$
Storage Temperature Range, T_{STG}	-65 to +150	$^{\circ}\text{C}$
Lead Temperature (Peak) (reflow - soldering 60sec. maximum above 183 $^{\circ}\text{C}$)	230	$^{\circ}\text{C}$
ESD, Human Body Model	1.2	kV

* The maximum package power dissipation must be observed.



FC3255 1.5A PWM Switching Regulators

◆ MAXIMUM RATINGS:

PIN NAME	PIN SYMBOL	V _{MAX}	V _{MIN}	I _{SOURCE}	I _{SINK}
IC Power Input	V _{CC}	30 V	-0.3 V	N / A	200 mA
Shutdown / Sync	SS	30 V	-0.3 V	1 mA	1 mA
Loop Compensation	V _C	6 V	-0.3 V	10 mA	10 mA
Voltage Feedback Input	FB	10 V	-0.3 V	1 mA	1 mA
Test Pin	Test	6 V	-0.3 V	1 mA	1.0 mA
Power Ground	PGND	0.3 V	-0.3 V	4 A	10 mA
Analog Ground	AGND	0 V	0 V	N / A	10 mA
Switch Input	V _{SW}	40 V	-0.3 V	10 mA	3 A

◆ BLOCK DIAGRAM

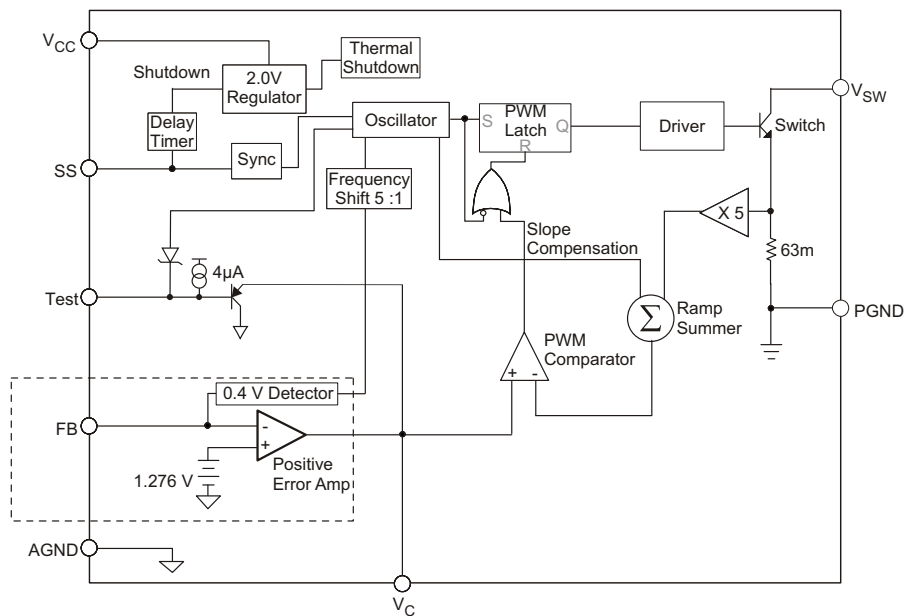



FC3255 1.5A PWM Switching Regulators

◆ ELECTRICAL CHARACTERISTICS

(2.7 V < V_{CC} < 30 V; Industrial Grade: 0°C < T_J < 70°C; Commercial Grade: 0°C < T_J < 125°C; unless otherwise noted)

CHARACTERISTICS	TEST CONDITIONS	MIN	TYP	MAX	UNIT
Error Amplifier Section					
FB Reference Voltage	V _C tied to FB; measure at FB	1.246	1.276	1.300	V
FB Input Current	FB = V _{REF}	-1.0	0.1	1.0	μA
FB Reference Voltage Line Regulation	V _C = FB	-	0.01	0.03	% / V
Error Amp Transconductance	I _{V_C} = ±25 μA	300	550	800	μMho
Error Amp Gain	(Note 2)	200	500	-	V / V
Negative Error Amp Gain	(Note 2)	100	180	320	V / V
V _C Source Current	FB = 1.0V, V _C = 1.25V	25	50	90	μA
V _C Sink Current	FB = 1.5V, V _C = 1.25V	200	625	1500	μA
V _C High Clamp Voltage	FB = 1.0V; V _C sources 25μA	1.5	1.7	1.9	V
V _C Low Clamp Voltage	FB = 1.5V, V _C sinks 25μA	0.25	0.50	0.65	V
V _C Threshold	Reduce V _C from 1.5V until switching stops	0.75	1.05	1.30	V
Oscillator Section					
Base Operating Frequency	FB = 1.0V	230	280	310	kHz
Reduced Operating Frequency	FB = 0V	30	52	120	kHz
Maximum Duty Cycle	-	90	94	-	%
FB Frequency Shift Threshold	Frequency drops to reduced operating frequency	0.36	0.40	0.44	V
Sync/ Shutdown Section					
Sync Range	-	320	-	500	kHz
Sync Pulse Transition Threshold	Rise time = 20ns	2.5	-	-	V
SS Bias Current	SS = 0V SS = 3.0V	-15 -	-3.0 3.0	- 8.0	μA
Shutdown Threshold	-	0.5	0.85	1.2	μs
Shutdown Delay	2.7 V ≤ V _{CC} ≤ 12V 12 V < V _{CC} ≤ 30V	12 12	80 36	350 200	μs

(Note 1) The maximum package power dissipation must be observed.

(Note 2) Guaranteed by design, not 100% tested in production.



FC3255 1.5A PWM Switching Regulators

◆ ELECTRICAL CHARACTERISTICS

(2.7 V < V_{CC} < 30 V; Industrial Grade: 0°C < T_J < 70°C; Commercial Grade: 0°C < T_J < 125°C; unless otherwise noted)

CHARACTERISTICS	TEST CONDITIONS	MIN	TYP	MAX	UNIT
Power Switch Section					
Switch Saturation Voltage	I _{SWITCH} = 1.5A, (Note 2)	-	0.8	1.4	V
	I _{SWITCH} = 1.0A, 0°C ≤ T _J ≤ 85°C	-	0.55	1.00	
	I _{SWITCH} = 1.0A, -40°C ≤ T _A ≤ 0°C (Note 2)	-	0.75	1.30	
	I _{SWITCH} = 10mA	-	0.09	0.45	
Switch Current Limit	50% duty cycle (Note 2) 80% duty cycle (Note 2)	1.6 1.5	1.9 1.7	2.4 2.2	A
Minimum Pulse Width	FB = 0 V, I _{SW} = 4.0A (Note 2)	200	250	300	ns
I _{CC} / V _{SW}	2.7 V ≤ V _{CC} ≤ 12V, 10mA ≤ I _{SW} ≤ 1.0A	-	10	30	mA / A
	12V ≤ V _{CC} ≤ 30V, 10mA ≤ I _{SW} ≤ 1.0A	-	-	100	
	2.7 V ≤ V _{CC} ≤ 12V, 10mA ≤ I _{SW} ≤ 1.5A (Note 2)	-	17	30	
	12V ≤ V _{CC} ≤ 30V, 10mA ≤ I _{SW} ≤ 1.5A (Note 2)	-	-	100	
Switch Leakage	V _{SW} = 40 V, V _{CC} = 0V	-	2.0	100	μA
General Section					
Operating Current	I _{SW} = 0	-	5.5	8.0	mA
Shutdown Mode Current	V _C < 0.8V, SS = 0V, 2.7V ≤ V _{CC} ≤ 12V	-	12	60	μA
	V _C < 0.8V, SS = 0V, 12V ≤ V _{CC} ≤ 30V	-	-	100	
Minimum Operation Input Voltage	V _{SW} switching, maximum I _{SW} = 10mA	-	2.45	2.70	V
Thermal Shutdown	(Note 2)	150	180	210	°C
Thermal Hysteresis	(Note 2)	-	25	-	°C

(Note 2) Guaranteed by design, not 100% tested in production.



◆ TYPICAL PERFORMANCE CHARACTERISTICS

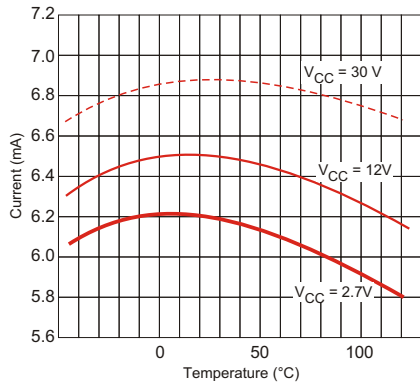

Figure 1. I_{CC} (No Switching) vs. Temperature

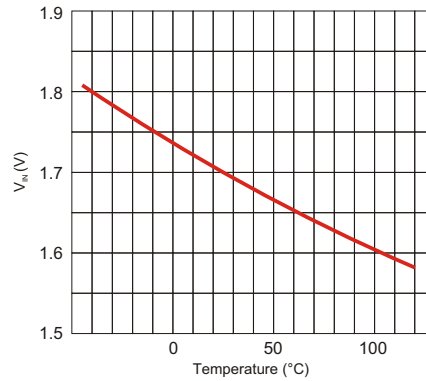

Figure 2. Minimum Input Voltage vs. Temperature

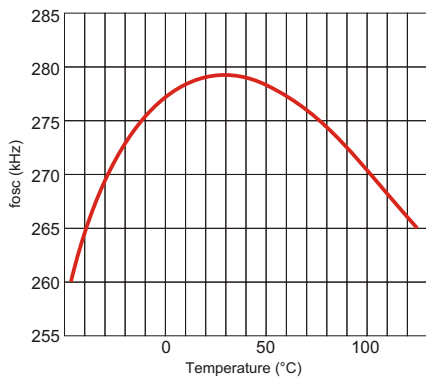

Figure 3. Switching Frequency vs. Temperature (GM3255 only)

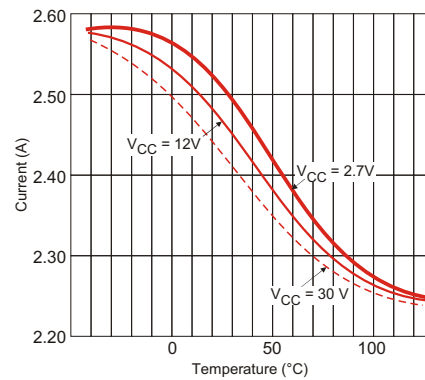

Figure 4. Current Limit vs. Temperature

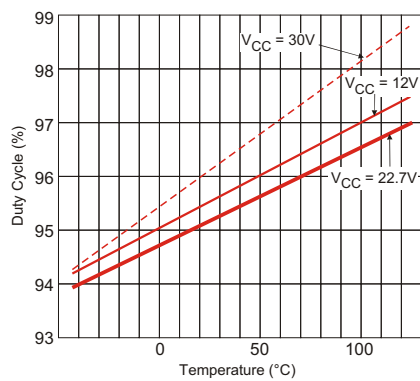

Figure 5. Maximum Duty Cycle vs. Temperature



◆ APPLICATION INFORMATION

Current Mode Control

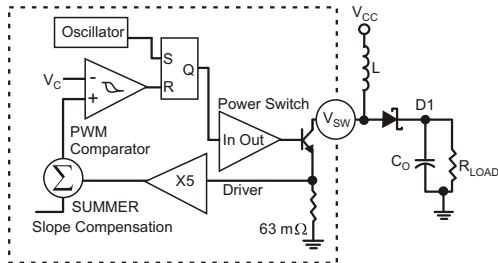
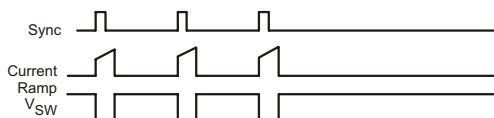

Figure 6. Current Mode Control Scheme

The 3255 family incorporates a current mode control scheme. In which the PWM ramp signal is derived from the power switch current. This ramp signal is compared to the output of the error amplifier to control the on-time power switch. The oscillator is used as a fixed-frequency clock to ensure a constant operational frequency. The resulting control scheme features several advantages over conventional voltage mode control. First, derived directly from the inductor, the ramp signal responds immediately to line voltage changes. This eliminates the delay caused by the output filter and error amplifier, which is commonly found in voltage mode controllers. The second benefit comes from inherent pulse-by-pulse current limiting by merely clamping the peak switching current. Finally, current mode commands an output current rather than voltage, then the filter offers only a single pole to the feedback loop. This allows both a simpler compensation and a higher gain-bandwidth over a comparable voltage mode circuit.

Without discrediting its apparent merits, current mode control comes with its own peculiar problems, and mainly subharmonic oscillation at duty cycles over 50%. The 3255 family solves this problem by adopting a slope compensation scheme, in which, a fixed ramp generated by the oscillator is added to the current ramp. A proper slope rate is provided to improve circuit stability without sacrificing the advantages of current mode control.

Oscillator and Shutdown



Shown in Figure 6. The power switch is turned off by the output of the PWM Comparator.

A TTL-compatible sync input at the SS pin is capable of syncing up to 1.8 times the base oscillator frequency. As shown in Figure 7, in order to sync to higher frequency, a positive transition turns on the power switch before the output of the oscillator goes high, thereby resetting the oscillator. The sync operation allows multiple power supplies to operate at the same frequency.

A sustained logic low at the SS pin will shut down the IC and reduce the supply current.

An additional feature includes frequency shift to 20% of the nominal frequency when either the NFB or FB pins trigger the threshold. During power up, overload, or short circuit conditions, the minimum switch on-time is limited by the PWM comparator minimum pulse width. Extra switch off-time reduces the minimum duty cycle to protect external components and the IC itself.

As Previously mentioned, this block also produces a ramp for the slope compensation to improve regulator stability.

Error Amplifier

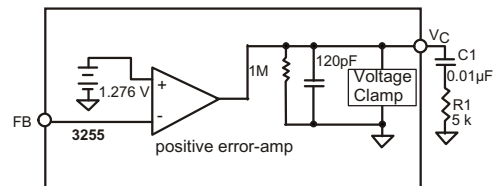

Figure 8. Error Amplifier Equivalent Circuit

The FB pin is directly connected to the inverting input of the positive error amplifier, whose non-inverting input is fed by the 1.276V reference. The amplifier is transconductance amplifier with a high output impedance of approximately 1MΩ, as shown in Figure 8. The V_C pin is connected to the output of the error amplifiers and is internally clamped between 0.5V and 1.7V. A typical connection at the V_C pin includes a capacitor in series with a resistor to ground, forming a pole / zero for loop compensation.

An external shunt can be connected between the V_C pin and ground to reduce its clamp voltage.



Consequently, the current limit of the internal power transistor current is reduced from its nominal value.

Switch Driver and Power Switch

The switch driver receives a control signal from the logic section to drive the output power switch. The switch is grounded through emitter resistors (63m total) to the PGND pin. PGND is not connected to the IC substrate so that switching noise can be isolated from the analog ground. The peak switching current is clamped by an internal circuit. The clamp current is guaranteed to be greater than 1.5A and varies with duty cycle due to slope compensation. The power switch can withstand a maximum voltage of 40V on the collector(V_{SW} pin). The saturation voltage of the switch is typically less than 1V to minimize power dissipation.

Short Circuit Condition

When a short circuit condition happens in a boost circuit, the inductor current will increase during the whole switching cycle, causing excessive current to be drawn from the input power supply. Since control ICs don't have the means to limit load current, an external current limit circuit(such as a fuse or relay) has to be implemented to protect the load, power supply and ICs.

In other topologies, the frequency shift built into the IC prevents damage to the chip and external components. This feature reduces the minimum duty cycle and allows the transformer secondary to absorb excess energy before the switch turns back on.

3255 can be activated by either connecting the V_{CC} pin to a voltage source or by enabling the SS pin.

When the V_{CC} voltage is below the minimum supply voltage, the V_{SW} pin is in high impedance. Therefore, current conduces directly from the input power source to the output through the inductor and diode. Once V_{CC} reaches approximately 1.5V, the internal power switch briefly turns on. This is a part of normal operation. The turn-on of the power switch accounts for the initial current swing.

When the V_C pin voltage rises above the threshold, the internal power switch starts to switch and a voltage pulse can be seen at the V_{SW} pin. Detecting a low output voltage at the FB pin, the built-in frequency shift feature reduces the switching frequency to a fraction of its nominal value, reducing the minimum duty cycle, which is otherwise limited by the minimum on-time of the switch. The peak current during this phase is clamped by the internal current limit.

When the FB pin voltage rises above 0.4V, the frequency increases to its nominal value, and the peak current begins to decrease as the output approaches the regulation voltage. The overshoot of the output voltage is prevented by the active pull-on, by which the sink current of the error amplifier is increased once an overvoltage condition is detected. The overvoltage condition is defined as when the FB pin voltage is 50mV greater than the reference voltage.

COMPONENT SELECTION

Frequency Compensation

The goal of frequency compensation is to achieve desirable transient response and DC regulation while ensuring the stability of the system. A typical compensation network, as shown in Figure 9, provides a frequency response of two poles and one zero. This frequency response is further illustrated in the Bode plot shown in Figure 9.

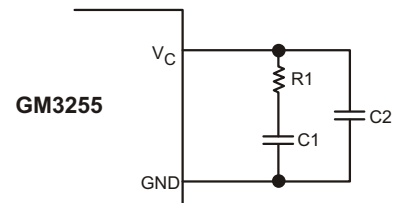

Figure 9. A Typical Compensation Network

The high DC gain in Figure 10 is desirable for achieving DC accuracy over ling and load variations. The DC gain of a transconductance error amplifier can be calculated as follows:

$$\text{Gain}_{DC} = G_M \times R_O$$

Where:

G_M = error amplifier transconductance;

R_O = error amplifier output resistance ≈ 1M

The low frequency pole, f_{p1}, is determined by the error amplifier output resistance and C1 as:

$$f_{p1} = \frac{1}{2 \times C1R_O}$$

The first zero generated C1 and R1 is:

$$f_{z1} = \frac{1}{2 \times C1R1}$$



The phase lead provided by this zero ensures that the loop has at least a 45° phase margin at the crossover frequency. Therefore, this zero should be placed close to the pole generated in the power stage, which can be identified at frequency:

$$f_{P1} = \frac{1}{2 C_O R_{LOAD}}$$

where:

C_O = equivalent output capacitance of the error amplifier $\approx 120\text{pF}$;
 R_{LOAD} = load resistance.

The high frequency pole, f_{P2} , can be placed at the output filter's ESR zero or at half the switching frequency. Placing the pole at this frequency will cut down on switching noise. The frequency of this pole is determined by the value of $C2$ and $R1$:

$$f_{P2} = \frac{1}{2 C1 R1}$$

One simple method to ensure adequate phase margin is to design the frequency response with a -20 dB per decade slope, until unity-gain crossover. The crossover frequency should be selected at the midpoint between f_{Z1} and f_{P2} where the phase margin is maximized.

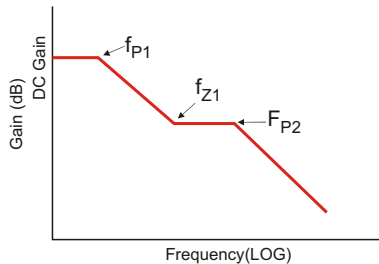

Figure 10. Bode Plot of the Compensation Network Shown in Figure 9.

V_{SW} Voltage Limit

In the boost topology, V_{SW} pin maximum voltage is set by the maximum output voltage plus the output diode forward voltage. The diode forward voltage is typically 0.5V for Schottky diodes and 0.8V for ultrafast diodes

$$V_{SW(MAX)} = V_{OUT(MAX)} + V_F$$

Where:

V_F = output diode forward voltage.

In the flyback topology, peak V_{SW} voltage is governed by:

$$V_{SW(MAX)} = V_{CC(MAX)} + (V_{OUT} + V_F) \times N$$

Where:

N = transformer turns ratio, primary over secondary

When the power switch turns off, there exists a voltage spike superimposed on top of the steady-state voltage. Usually, this voltage spike is caused by transformer leakage inductance charging stray capacitance between the V_{SW} and PGND pins. To prevent the voltage at the V_{SW} pin from exceeding the maximum rating, a transient voltage suppressor in series with a diode is paralleled with the primary windings. Another method of clamping switch voltage is to connect a transient voltage suppressor between the V_{SW} pin and ground.

Magnetic Component Selection

When choosing a magnetic component, one must consider factors such as peak current, core and ferrite material, output voltage ripple, EMI, temperature range, physical size, and cost. In boost circuits, the average inductor current is the product of output current and voltage gain (V_{OUT} / V_{CC}), assuming 100% energy transfer efficiency. In continuous conduction mode, inductor ripple current is

$$I_{RIPPLE} = \frac{V_{CC}(V_{OUT} - V_{CC})}{(f)(L)(V_{OUT})}$$

where:

$f = 280\text{kHz}$.

The peak inductor current is equal to average current plus half of the ripple current, which should not cause inductor saturation. The above equation can also be referenced when selecting the value of the inductor based on the tolerance of the ripple current in the circuits. Small ripple current provides the benefits of small input capacitors and greater output current capability. A core geometry like a rod or barrel is prone to generating high magnetic field radiation, but is relatively cheap and small. Other core geometries, such as toroids, provide a closed magnetic loop to prevent EMI.

Input Capacitor Selection

In boost circuits, the inductor becomes part of the input filter, as shown in Figure 11. In continuous mode, the input current waveform is triangular and does not contain a large pulsed current. During continuous conduction mode, the peak to peak inductor ripple current is given in the previous section. In most applications, input capacitors in the range of $10\mu\text{F}$ to $100\mu\text{F}$ with an ESR less than 0.3 work well up to a full 1.5A switch current.

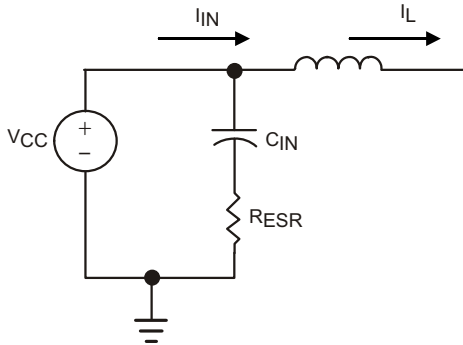

Figure 11. Boost Circuit Effective Input Filter

The situation is different in a flyback circuit. The input current is discontinuous and a significant pulse current is seen by the input capacitors. Therefore, there are two requirements for capacitors in a flyback regulator: energy storage and filtering. To maintain a stable voltage supply to the chip, a storage capacitor larger than 20µF with low ESR is required. To reduce the noise generated by the inductor, insert a 1.0µF ceramic capacitor between V_{CC} and ground as close as possible to the chip.

When the power switch is turned on, I_L is shunted to ground and I_{OUT} discharges the output capacitor. When the I_L ripple is small enough, I_L can be treated as a constant and is equal to input current I_{IN}. Summing up, the output voltage peak-peak ripple can be calculated by:

$$V_{OUT(RIPPLE)} = \frac{(I_{IN} - I_{OUT})(1 - D)}{(C_{OUT})(f)} + \frac{I_{OUT}D}{(C_{OUT})(f)} + I_{IN} \times ESR$$

The equation can be expressed more conveniently in terms of V_{CC}, V_{OUT} and I_{OUT} for design purposes as follows:

$$V_{OUT(RIPPLE)} = \frac{I_{OUT}(V_{OUT} - V_{CC})}{(C_{OUT})(f)} \times \frac{1}{(C_{OUT})(f)} + \frac{(I_{OUT})(V_{OUT})(ESR)}{V_{CC}}$$

The capacitor RMS ripple current is:

$$I_{RIPPLE} = \sqrt{(I_{IN} - I_{OUT})^2 (1 - D) + (I_{OUT})^2 (D)} = I_{OUT} \sqrt{\frac{V_{OUT} - V_{CC}}{V_{CC}}}$$

Although the above equations apply only for boost circuits, similar equations can be derived for flyback circuits.

Reducing the Current Limit

In some applications, the designer may prefer a lower limit on the switch current than 1.5A. An external shunt can be connected between the V_C pin and ground to reduce its clamp voltage. Consequently, the current limit of the internal power transistor current is reduced from its nominal value.

The voltage on the V_C pin can be evaluated with the equation

$$V_C = I_{SW} R_E A_V$$

where:

R_E = 0.063 Ω, the value of the internal emitter resistor; A_V = 5V/V, the gain of the current sense amplifier. Since R_E and A_V cannot be changed by the end user, the only available method for limiting switch current below 1.5A is to clamp the V_C pin at a lower voltage. If the maximum switch or inductor current is substituted into the equation above, the desired clamp voltage will result.

A simple clamp, as shown in Figure 12, clamps the V_C voltage to a diode drop above the voltage on resistor R3. Unfortunately, such a simple circuit is not generally acceptable if V_{IN} is loosely regulated.

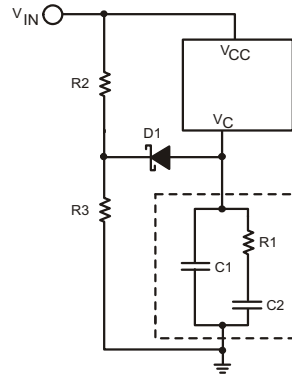

Figure 12. Current Limiting using a Diode Clamp



Another solution to the current limiting problem is to externally measure the current through the switch using a sense resistor. Such a circuit is illustrated in Figure 13.

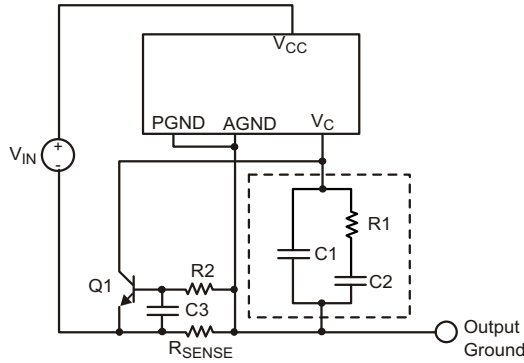

Figure 13. Current Limiting using a Current Sense Resistor

The switch current is limited to

$$I_{\text{SWITCH(PEAK)}} = \frac{V_{\text{BE(Q1)}}}{R_{\text{SENSE}}}$$

Where:

$V_{\text{BE(Q1)}}$ = the base - emitter voltage drop of Q1, typically 0.65V.

The improved circuit does not require a regulated voltage to operate properly. Unfortunately, a price must be paid for this convenience in the overall efficiency of the circuit. The designer should note that the input and output grounds are no longer common. Also, the addition of the current sense resistor, R_{SENSE} , results in a considerable power loss which increase with the duty cycle. Resistor R2 and capacitor C3 form a low - pass filter to remove noise.

Subharmonic Oscillation

Subharmonic oscillation (SHM) is a problem found in Current-mode control systems, where instability results when duty cycle exceeds 50%. SHM only occurs in switching regulators with a continuous inductor current. This instability is not harmful to the converter and usually does not affect the output voltage regulation. SHM will increase the radiated EM noise from the converter and can cause, under certain circumstances, the inductor to emit high - frequency audible noise.

SHM is an easily remedied problem. The rising slope of the inductor current is supplemented with internal "slope compensation" to prevent any duty cycle instability from carrying through to the next switching cycle. In the 3255, slope compensation is added during the entire switch on-time, typically in the amount of 180 mA/μs.

In some cases, SHM can rear its ugly head despite the presence of the onboard slope compensation. The simple cure to this problem is more slope compensation avoid the unwanted oscillation. In that case, an external circuit, shown in Figure 14, can be added to increase the amount of slope compensation used. This circuit requires only a few components and is "tacked on" to the compensation network.

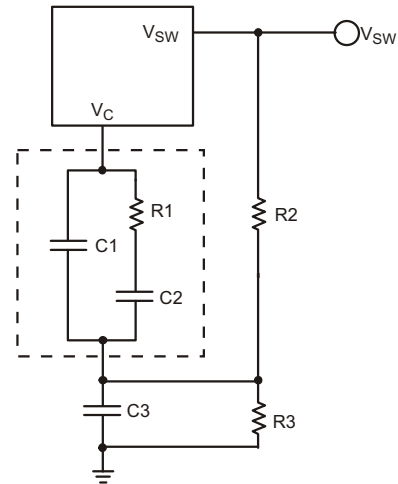

Figure 14. Technique for Increasing Slope Compensation

The dashed box contains the normal compensation circuitry to limit the bandwidth of the error amplifier. Resistors R2 and R3 form a voltage divider off of the V_{SW} pin. In normal operation V_{SW} looks similar to a square wave, and is dependent on the converter topology.

Formulas for calculating V_{SW} in the boost and flyback topologies are given in the section " V_{SW} Voltage Limit." The voltage on V_{SW} charges capacitor C3 when the switch is off, causing the voltage at the V_{C} pin to shift upwards. When the switch turns on, C3 discharges through R3, producing a negative slope at the V_{C} pin. The negative slope provides the slope compensation.

The amount of slope compensation added by this circuit is

$$\frac{I}{T} = V_{\text{SW}} \left(\frac{R3}{R2 + R3} \right) \left(1 - e^{-\frac{(1-D)}{R3 C3 f_{\text{SW}}}} \right) \left(\frac{f_{\text{SW}}}{(1-D) R_E A_V} \right)$$



Where:

- I/T = the amount of slope compensation added (A/s);
- V_{SW} = the voltage at the switch node when the transistor is turned off (V);
- f_{SW} = the switching frequency, typically 280kHz (3255) or 560kHz
- D = the duty cycle;
- $R_E = 0.063$, the value of the internal emitter resistor;
- $A_V = 5V/V$, the gain of the current sense amplifier.

In selecting appropriate values for the slope compensation network, the designer is advised to choose a convenient capacitor, then select values for R2 and R3 such that the amount of slope compensation added is 100mA / μ s. Then R2 may increased or decreased as necessary. Of course, the series combination of R2 and R3 should be large enough to avoid drawing excessive current from V_{SW} . Additionally, to ensure that the control loop stability is improved, the time constant formed by the additional components should be chosen such that

$$R_3 C_3 < \frac{1-D}{f_{SW}}$$

Finally, it is worth mentioning that the added slope compensation is a trade-off between duty cycle stability and transient response. The more slope compensation a designer adds, the slower the transient response will be, due to the external circuitry interfering with the proper operation of the error amplifier.

Soft Start

Through the addition of an external circuit, a soft-start function can be added to 3255 of components. Soft-start circuitry prevents the V_C pin from slamming high during startup, thereby inhibiting the inductor current from rising at a high slope.

This circuit, shown in Figure 15, requires a minimum number of components and allows the soft-start circuitry to activate any time the SS pin is used to restart the converter.

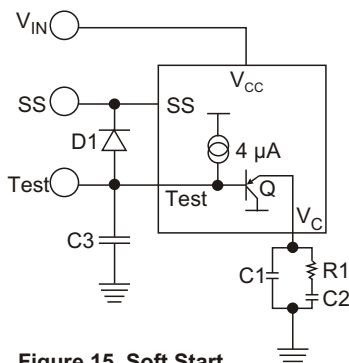

Figure 15. Soft Start

Resistor R1 and capacitors C1 and C2 form the compensation network. At turn on, the voltage at the V_C pin starts to come up, charging capacitor C3 through Schottky diode D2, clamping the voltage at the V_C pin such that switching begins when V_C reaches the V_C threshold, typically 1.05V (refer to graphs for detail over temperature).

$$V_C = V_{F(D2)} + V_{C3}$$

Therefore, C3 slows the startup of the circuit by limiting the voltage on the V_C pin. The soft-start time increases with the size of C3.

Diode D1 discharges C3 when SS is low. If the shut-down function is not used with this part, the cathode of D1 should be connected to V_{IN} .

Calculating Junction Temperature

To ensure safe operation of the GM3255, the designer must calculate the on-chip power dissipation and determine its expected junction temperature. Internal thermal protection circuitry will turn the part off once the junction temperature exceeds $180^\circ\text{C} \pm 30^\circ\text{C}$. However, repeated operation at such high temperatures will ensure a reduced operating life.

Calculation of the junction temperature is an imprecise but simple task. First, the power losses must be quantified. There are three major sources of power loss on 3255:

- Biasing of internal control circuitry, P_{BIAS}
- Switch driver, P_{DRIVER}
- Switch saturation, P_{SAT}

The internal control circuitry, including the oscillator and linear regulator, requires a small amount of power even when the switch is turned off. The specifications section of this datasheet reveals that the typical operating current I_Q , due to this circuitry is 5.5 mA.

Additional guidance can be found in the graph of operating current vs. temperature. This graph shows that I_Q is strongly dependent on input voltage, V_{IN} , and temperature. Then

$$P_{BIAS} = V_{IN} I_Q$$

Since the onboard switch is an NPN transistor, the base drive current must be factored in as well. This current is drawn from the V_{IN} pin, in addition to the control circuitry current. The base drive current is listed in the specifications as I_{CC}/I_{SW} , or switch transconductance. As before the designer will find additional guidance in the graphs. With that information, the designer can calculate

$$P_{DRIVER} = V_{IN} I_{SW} \times \frac{I_{CC}}{I_{SW}} \times D$$



Where

I_{SW} = the current through the switch;

D = the duty cycle or percentage of switch on-time.

I_{SW} and D are dependent on the type of converter. In a boost convert,

$$I_{SW(AVG)} = I_{LOAD} \times D \times \frac{1}{\text{Efficiency}}$$

$$D = \frac{V_{OUT} - V_{IN}}{V_{OUT}}$$

In a flyback converter,

$$I_{SW(AVG)} = \frac{V_{OUT} I_{LOAD}}{V_{IN}} \times \frac{1}{\text{Efficiency}}$$

$$D = \frac{V_{OUT}}{V_{OUT} + \frac{N_S}{N_P} V_{IN}}$$

The switch saturation voltage, $V_{(CE)SAT}$, is the last major source of on-chip power loss. $V_{(CE)SAT}$ is the collector-emitter voltage of the internal NPN transistor when it is driven into saturation by its base drive current. The value for $V_{(CE)SAT}$ can be obtained from the specifications or from the graphs, as "Switch Saturation Voltage." Thus,

$$P_{SAT} = V_{(CE)SAT} I_{SW} \times D$$

Finally, the total on-chip power losses are

$$P_D = P_{BIAS} + P_{DRIVER} + P_{SAT}$$

Power dissipation in a semiconductor device results in the generation of heat in the junctions at the surface of the chip. This heat is transferred to the surface of the IC package, but a thermal gradient exists due to the resistive properties of the package molding compound. The magnitude of the thermal gradient is expressed in manufacturers' data sheets as θ_{JA} , or junction-to-ambient thermal resistance. The on-chip junction temperature can be calculated if θ_{JA} , the air temperature near the surface of the IC, and the on-chip power dissipation are known.

$$T_J = T_A + (P_D \theta_{JA})$$

where:

T_J = IC or FET junction temperature (°C);

T_A = ambient temperature (°C);

P_D = power dissipated by part in question(W);

θ_{JA} = junction-to ambient thermal resistance (°C / W).

For 3255, $\theta_{JA} = 165^\circ\text{C} / \text{W}$. Once the designer has calculated T_J , the question of whether the 3255 can be used in an application is settled. If T_J exceeds 150°C , the absolute maximum allowable junction temperature, the 3255 is not suitable for that application.

If T_J approaches 150°C , the designer should consider possible means of reducing the junction temperature. Perhaps another converter topology could be selected to reduce the switch current. Increasing the airflow across the surface of the chip might be considered to reduce T_A .

Output Setting

3255 develops a 1.276 V reference (V_{REF}) from the FB pin to ground. Output voltage is set by connecting the FB pin to an output resistor divider (Figure 16). The FB pin bias current represents a small error and can usually be ignored for values of R2 up to 7k. The suggested value for R2 is 6.19k.

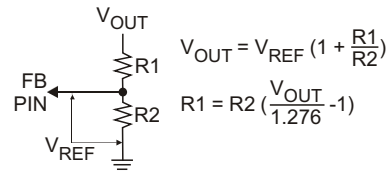

Figure 16. Output Resistor Divider

Circuit Layout Guidelines

In any switching power supply, circuit layout is very important for proper operation. Rapidly switching currents combined with trace inductance generates voltage transitions that can cause problems. Therefore the following guidelines should be followed in the layout.

1. In boost circuits, high AC current circulates within the loop composed of the diode, output capacitor, and on-chip power transistor. The length of associated traces and leads should be kept as short as possible. In the flyback circuit, high AC current loops exist on both sides of the transformer. On the primary side, the loop consists of the input capacitor, transformer, and on-chip power transistor, while the transformer, rectifier diodes, and output capacitors form another loop on the secondary side. Just as in the boost circuit, all traces and leads containing large AC current should be kept short.
2. Separate the low current signal grounds from the power grounds. Use single point grounding or ground plane construction for the best results.
3. Locate the voltage feedback as near the IC as, possible to keep the sensitive feedback wiring short. Connect feedback resistors to the low current analog ground.



FC3255 1.5A PWM Switching Regulators

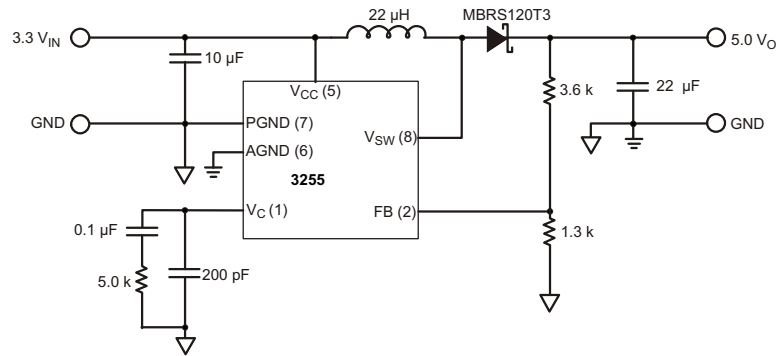

Figure 17. Additional Application Diagram, 3.3 V Input, 5.0 V/ 400mA Output Boost Converter

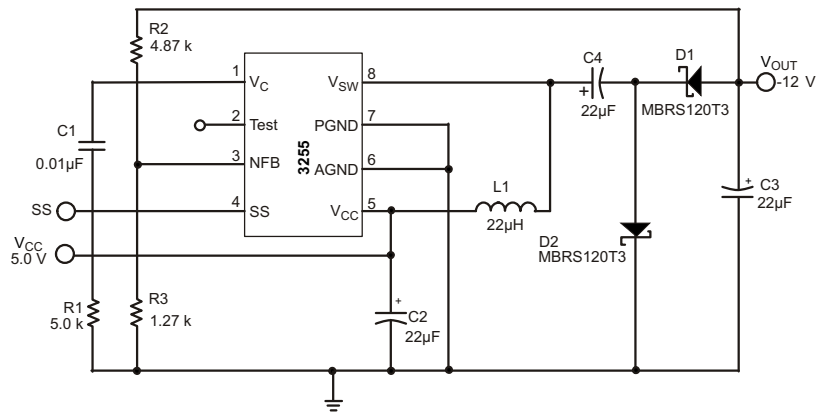

Figure 18. Additional Application Diagram, 5.0V to -12V/ 75mA Inverting Converter

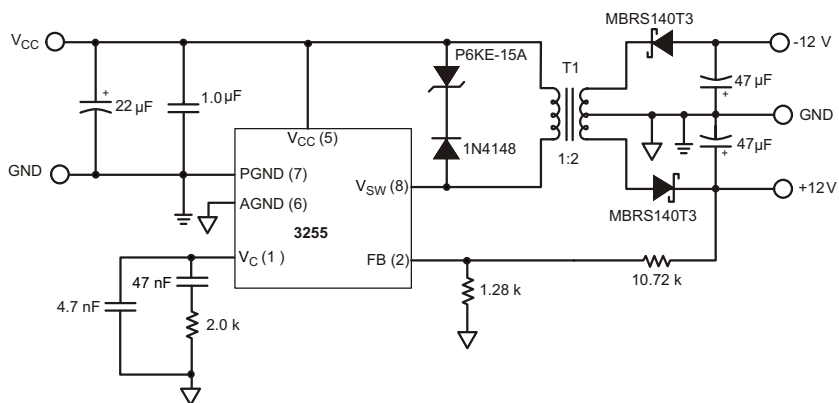

Figure 19. Additional Application Diagram, 2.7 to 13 V Input, ±12 V/ 200 mA Output Flyback Converter



FC3255 1.5A PWM Switching Regulators

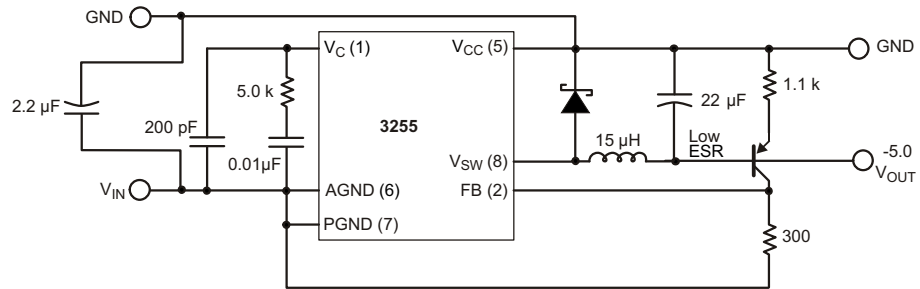

Figure 20. Additional Application Diagram, -9.0 V to -28 V Input, -5.0 V/700 mA Output Inverted Buck Converter

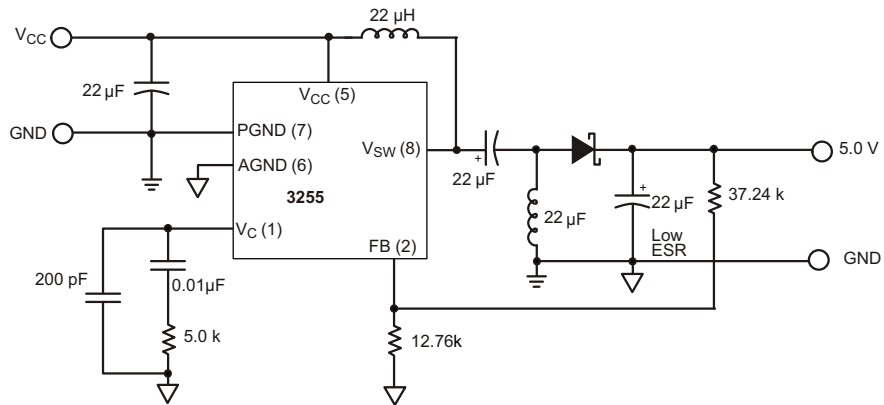

Figure 21. Additional Application Diagram, 2.7 V to 28 V Input, 5.0 V Output SEPIC Converter

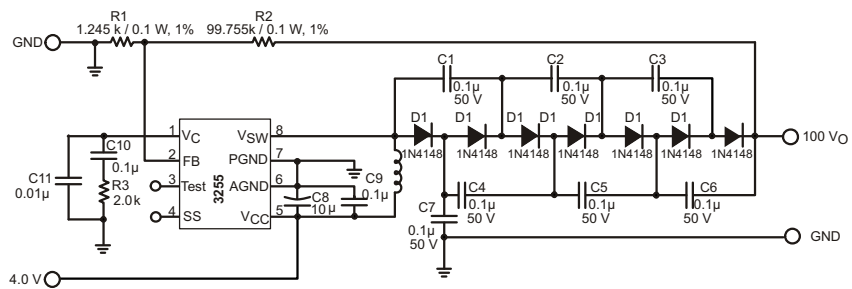

Figure 22. Additional Application Diagram, 4.0 V Input, 100 V/ 10 mA Output Boost Converter with Output Voltage Multiplier



FC3255 1.5A PWM Switching Regulators

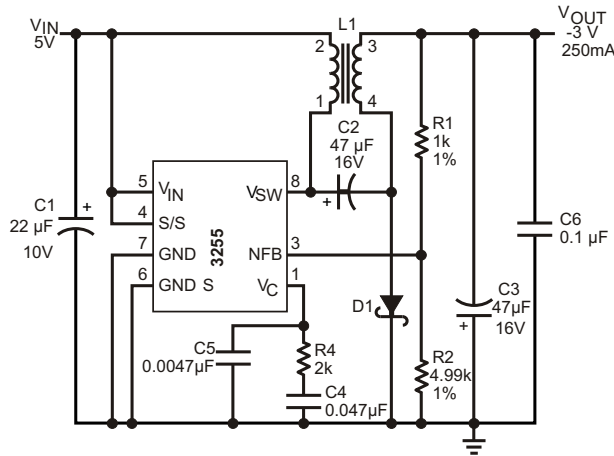

Figure 26. Low Ripple 5V to -3V "Cuk" Converter

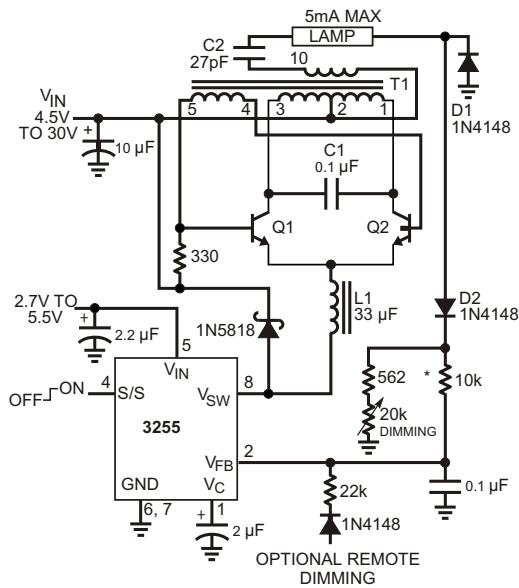

Figure 27. CCFL Supply

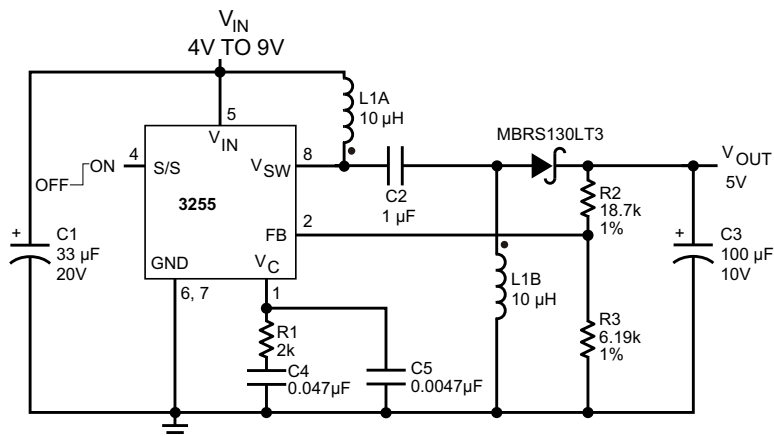

Figure 28. 2 Li - Lion Cell to 5V SEPIC Converter



FC3255 1.5A PWM Switching Regulators

◆ SOP-8 PACKAGE OUTLINE DIMENSIONS

