

Distributor: **Electro-Stock** www.electrostock.com Tel: 630-682-1542 Fax: 630-682-1562

FEATURES:

- H-Bridge contact configuration available
- Small size and light weight
- 25A switching capacity
- F Class materials standard
- QS-9000, ISO-9002 Certified Manufacturing



14.5 x 7.7 x 13.7 mm 14.5 x 14.0 x 14.3 mm

CONTACT DATA

Contact Arrangement	1C = SPDT 1H = H-Bridge
Contact Rating	25A @ 14VDC
Contact Resistance	< 50 milliohms initial
Contact Material	AgSnO ₂
Maximum Switching Power	480W
Maximum Switching Voltage	20VDC
Maximum Switching Current	30A

COIL DATA

Coil Voltage VDC		Coil Resistance Ω ± 10%		Pick Up Voltage VDC (max)	Release Voltage VDC (min)	Coil Power W	Operate Time ms	Release Time ms
Rated	Max.	.64W	.80W	75% of rated voltage	10% of rated voltage			
12	15.6	225	180	8.4	1.2	.64 & .80	10	5

CAUTION:

1. The use of any coil voltage less than the rated coil voltage may compromise the operation of the relay.
2. Pickup and release voltages are for test purposes only and are not to be used as design criteria.

GENERAL DATA

Electrical Life @ rated load	100K cycles, typical
Mechanical Life	10M cycles, typical
Insulation Resistance	100MΩ min @ 500VDC
Dielectric Strength, Coil to Contact	1500V rms min. @ sea level
Contact to Contact	1000V rms min. @ sea level
Shock Resistance	100m/s ² for 11ms
Vibration Resistance	1.27mm double amplitude 10-40Hz
Terminal (Copper Alloy) Strength	4N
Operating Temperature	-40 °C to + 105 °C
Storage Temperature	-40 °C to + 155 °C
Solderability	230 °C ± 2 °C for 10 ± 0.5s
Weight	4.1g

Distributor: **Electro-Stock** www.electrostock.com Tel: 630-682-1542 Fax: 630-682-1562

ORDERING INFORMATION

1. Series:	CTA16	1C	S	12VDC	.64
CTA16					
2. Contact Arrangement:					
1C = SPDT					
1H = H-bridge					
3. Sealing Options:					
S = Sealed					
C = Dust Cover					
4. Coil Voltage:					
12VDC					
5. Coil Power:					
.64 = .64W					
.80 = .80W					

DIMENSIONS (Units = mm)

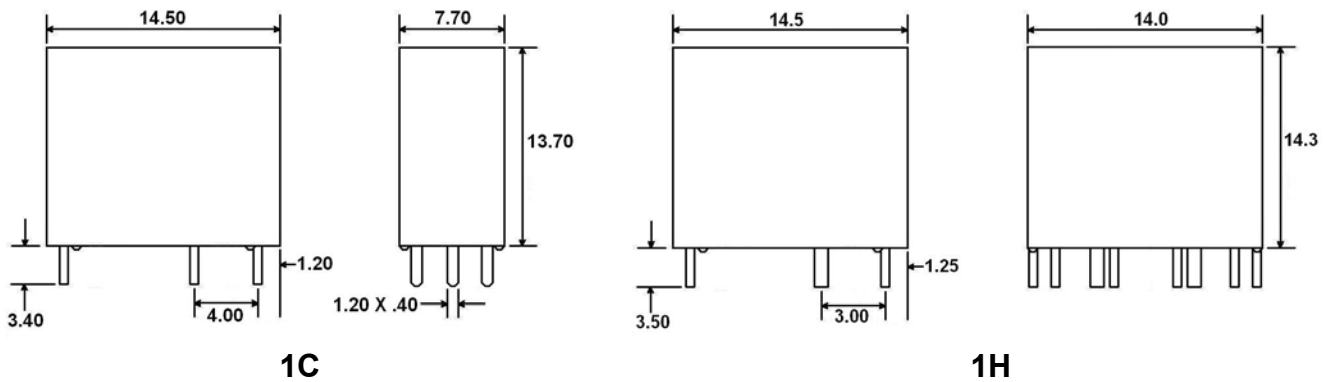

SCHEMATICS & PC LAYOUTS (BOTTOM VIEWS)

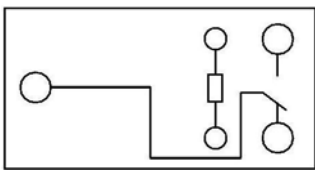

1C

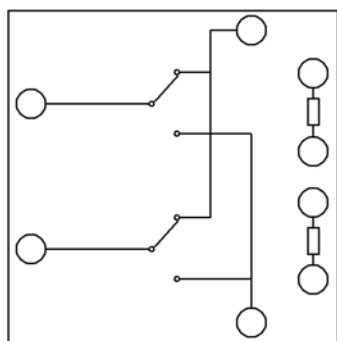
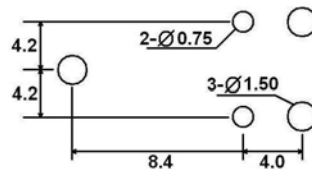

1H

