

ELM185xB Laser Diode Driver

■General description

ELM185xB is a bipolar type laser diode driver IC with internal APC circuit which consists of a reference voltage source, an error amplifier, and a thermal shutdown circuit for protection. With reference voltage source, the output of laser is comparatively stable during the change of power voltage and temperature. With its small package, ELM185xB is possible to be assembled within small areas on the board. When control loop damage occurs, ELM185xB is also capable of limiting the laser drive current; limited current value can be adjusted by an external resistor on ILM. KLD output drive current can reach up to 400mA (max.). For avoidance of damage of laser diode, the Zener diode which is included in ELM185xB is able to absorb 8V surge between VCC-GND.

ELM185xB is able to drive various types of laser diode modules (LDM); please refer to applicable laser diode modules for further information. ELM185xB can not only drive laser diode by APC control, but also by constant current with internal constant current setup function; therefore, ELM185xB can also be used as constant current driver for laser diode, high luminous LED, etc.

■Features

- Low voltage operation : 2.0V
- Low current consumption operation : Typ.1mA
- Laser drive current : Max.400mA
- Internal voltage reference : Typ.0.30V
- Thermal shutdown circuit : Typ.150°C
- Package : SOT-26, VSON6-2x2
- Zener diode for surge absorption included

■Application

- Driver for laser diode in laser pointer, laser level, etc.
- Driver for constant load current such as LED, etc.

■Maximum absolute ratings

Parameter	Symbol	Limit	Unit
Operation voltage	VCC	GND-0.3 to 7.0	V
CMP voltage	Vcmp	GND-0.3 to 7.0	V
ILM voltage	Vilm	GND-0.3 to 7.0	V
KLD voltage	Vkld	GND-0.3 to 18.0	V
AMD voltage	Vamd	GND-0.3 to VCC+0.3	V
KLD current	Ikld	500	mA
Power dissipation	Pd	300 (SOT-26)	mW
		1000 (VSON6-2x2)	
Operation temperature	Top	-30 to +85	°C
Storage temperature	Tstg	-40 to +125	°C

ELM185xB Laser Diode Driver

■ Selection guide

ELM185xB-S

Symbol		
a	Package	B: SOT-26, G: VSON6-2x2
b	Product version	B
c	Taping direction	S: Refer to PKG file

ELM185 x B - S
 ↑ ↑ ↑
 a b c

■ Pin configuration

SOT-26(TOP VIEW)

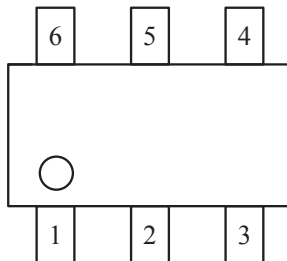

Pin No.	Pin Name
1	AMD
2	GND
3	CMP
4	ILM
5	VCC
6	KLD

VSON6-2x2(TOP VIEW)

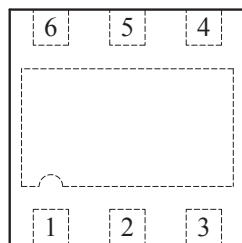

Pin No.	Pin Name
1	KLD
2	VCC
3	ILM
4	CMP
5	GND
6	AMD

VSON6-2x2(BOTTOM VIEW)

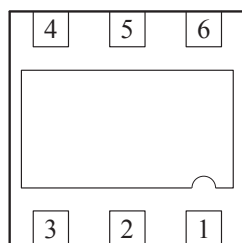

ELM185xB Laser Diode Driver

■Block diagram

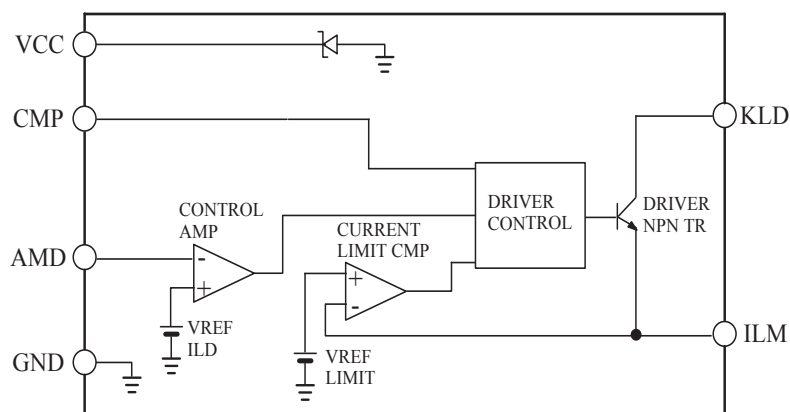

Pin description

Pin	Name	Content
AMD	LD monitor input	connected to anode of monitoring diode
CMP	phase compensation	input of phase compensation capacitor for control feedback loop stabilization
ILM	LD current limit	input of detection of laser diode driver drive current limit
KLD	LD drive output	connected to cathode of laser diode
VCC	power output	power input of IC
GND	ground	ground of IC

Description :

The internal APC circuit of ELM185xB controls the output of laser oscillation at constant value with the feedback of monitor photo diode light output current. Monitor photo diode light current will be changed to voltage by resistance and becomes the input of AMD; this voltage is set to be 0.3V, which is the same as the reference voltage inside IC. It is possible to acquire constant laser output by the laser diode drive current which is controlled by this voltage; hence, laser light output can be adjusted by the resistor connected to AMD.

Laser diode drive current can be changed to voltage by resistance connected to ILM, and the increase of this voltage is limited under current limit voltage (Typ.0.15V). ILM is also capable of avoiding the damage of overmuch drive current of laser diode which is caused by control loop abnormality.

For stability of control return loop, a phase compensation capacitor is required to be connected to CMP. Please set to small value at least above 3nF when making ON/OFF control with fast speed.

Laser diode is driven by the open collector output of NPN transistor inside ELM185xB; therefore, drive current (Max.18V) higher than power voltage of IC can be added as drive voltage of laser diode. ELM recommends inserting resistance between laser diode module (LDM) and KLD if the drive voltage is high so as to disperse power loss.

By monitor current detection function of ELM185xB, AMD can be used as ON/OFF control pin. It is also possible to control switching of laser diode when the input source is from external control signal; the ON/OFF control will become 0.3V threshold voltage.

By 7V voltage, the Zener diode between power and ground of ELM185xB is able to absorb power surge; meanwhile, the Zener diode is also capable of decreasing the damage of surge by clipping the surge voltage of power line.

ELM185xB Laser Diode Driver

■Electrical characteristics

Parameter	Symbol	Condition	Min.	Typ.	Max.	Unit
Operation voltage	VCC		2.0		6.5	V
Current consumption	ICC	VCC=3.6V		1	3	mA
AMDreference voltage	Vamd	VCC=3.6V	0.285	0.300	0.315	V
Vamd temperature characteristics	$\frac{\Delta V_{amd}}{\Delta T_{top}}$	VCC=3.6V		±200		ppm/°C
KLD current	IDkld	VCC=2.7V, Vkld=1.0V	400			mA
KLD leak current	ILkld	VCC=5.5V			1.0	μA
ILM current limit voltage	Vilm	VCC=3.6V	0.13	0.15	0.17	V
Max. external clock frequency	Fext	VCC=3.6V			20	kHz
AMD input current	Iamd	VCC=5.5V, Vamd=1.0V	-0.5		0.5	μA
Zener diode avalanche voltage	ZDBV		6.8		8.0	V

■Marking

SOT-26

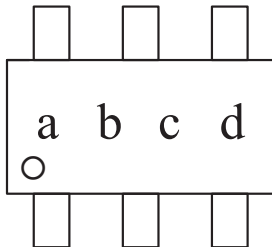

Symbol	Mark	Content
a, b, c	2NW	Series : 185
		Package : SOT-26
d	0 to 9 and A to Z (I, O, X excepted)	Assembly lot No.

VSON6-2x2

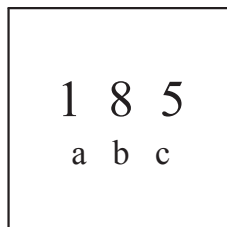

Symbol	Mark	Content
185	185	185 series
a, b, c	0 to 9 and A to Z (I, O, X excepted)	Assembly lot No.

ELM185xB Laser Diode Driver

■ Application circuit example 1 (continuous drive circuit)

Circuit that laser diode is driven by constant output continuously. LDM, which is the combination of laser diode (LD) and monitor diode (MD), is commonly used.

Based on various ways of handling poles and common pins, there are many different types of internal wire of anode and cathode of LDM. Examples which LDM can be easily connected to ELM185xB are shown as following three application circuits.

The fittest value of circuit constants will be different according to the used laser diode. Table 2 shows the example when the forward current of laser diode is 35mA and monitor diode light current is 0.1μA.

circuit (1)

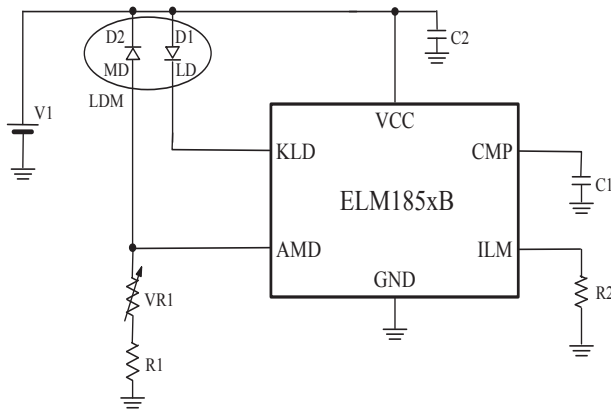

circuit (2)

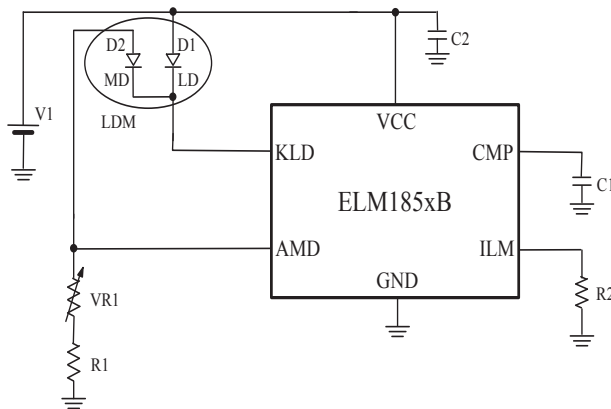

circuit (3)

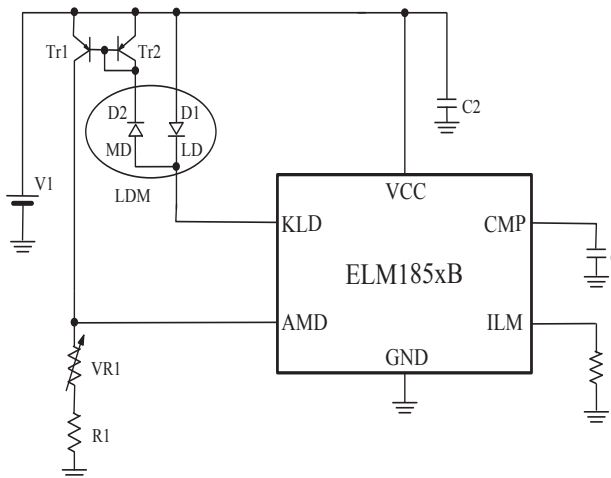

ELM185xB Laser Diode Driver

Typical Electric characteristics of LDM

table 1

Parameter	Symbol	Min.	Typ.	Max.	Unit
Action current	Iop	-	35	50	mA
Monitor current	Im	0.05	0.10	0.30	mA

Recommendation of absolute ratings of each circuit when using the LDM of table 1

table 2

No.	parts	Recommended absolute ratings	Notes
R1 *1	fixed resistor	1.0kΩ	LD output adjustment
VR1 *2	adjustable resistor	5.0kΩ	LD output adjustment
R2 *3	fixed resistor	3.3Ω	current limit setting (no limit under 0Ω)
C1	ceramic capacitor	3300pF	control loop stabilization
C2	electrolysis, ceramic, etc.	1μF to 100μF	power stabilization
Tr1 Tr2	PNP transistor	small signal transistor	monitor current mirror circuit

* 1 $R1=0.3/ I_m$ (Max.)

* 2 $(R1 + VR1) = 0.3/ I_m$ (Min.)

* 3 $R2=0.15/ I_{op}$ (Max.)

Application circuit example 2 (Pulse drive circuit)

For application circuit of intermittent diode output controlled by external signal, please refer to application circuit (4).

Max. frequency can set to be on/off by limit of response speed of laser diode output control loop is 20kHz. By using logic gate, the control of on/off is easy; it is required that the resistances of R1, R3 and VR1 are much larger than the output resistance of logic gate.

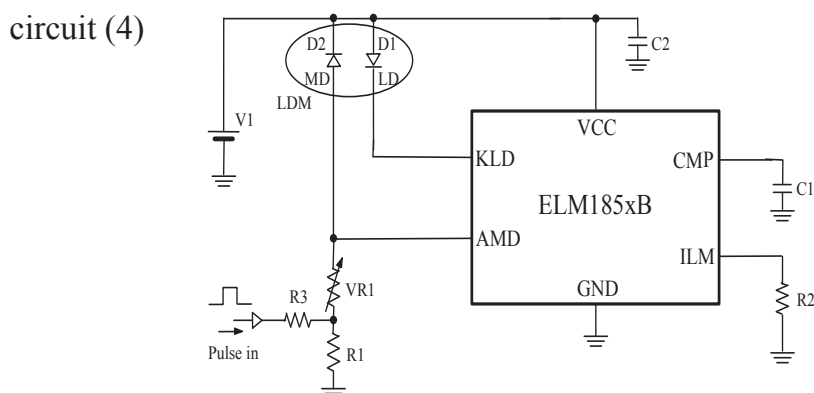

* For pulse drive, please add resistor to AMD pin in circuit (1) to control signal of pulse drive.

* Adjustable resistor (VR1) is inserted in the place as shown above in order to adjust monitor current; pulse drive control signal shall be added between R1 and VR1.

* R3: resistor of the input of pulse drive control signal. V_{CC} is set to be higher than $V_{amd}=0.30V$ (Typ.)

$$V_{CC} * R1 / (R3 + R1) > V_{amd}$$

e.g.) when $V_{CC}=3.3V$, $R1=1k\Omega$, $R3 < R1 * (V_{CC}-V_{amd})/V_{amd} = 1k\Omega * (3.3-0.3)/0.3 = 10k\Omega$.

* The control signal is logic level; laser light will be switched off when the signal is H and switched on when it is L.

ELM185xB Laser Diode Driver

• Pulse drive wave

This drive wave is tested base upon standard circuit (4) under the conditions that $R1=22k\Omega$, $R2=2.2\Omega$, $R3=220k\Omega$, $VR1=0$, $C1=3300pF$, $C2=1\mu F$, $V1=3.6V$

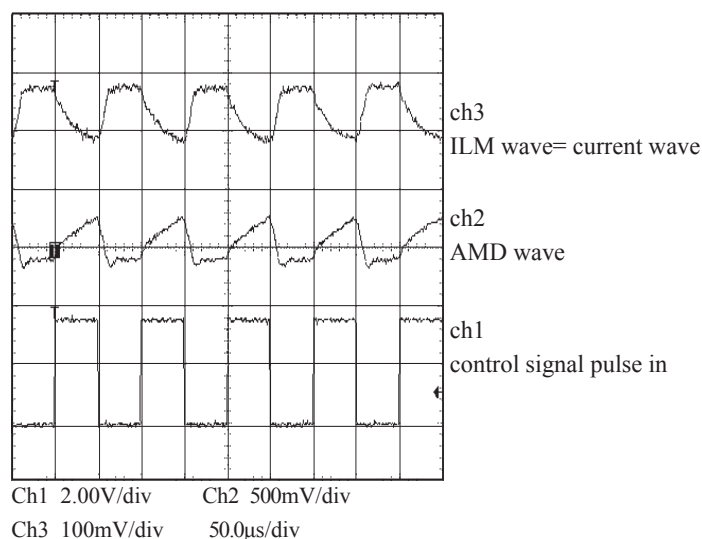

■ Application circuit example 3 (Drive circuit with detection circuit of single fault mode)

Based on different applications of laser, it is required that laser output can be maintained in safety region when single fault error happens. The example of single fault detection circuit is shown as application circuit (5).

If any of following 3 conditions happens, laser output of ELM185xB will be overmuch when single fault of all pin occurs:

- 1) Ground short fault happens to KLD (Ground current will be flowed directly from laser and thus result in overmuch of laser diode light output.)
- 2) Ground short fault happens to AMD (laser diode light output will be overmuch since output is judged to be 0)
- 3) VCC short fault happens to CMP (laser diode light output will be overmuch since circuit cannot be controlled.)

If any of these 3 conditions is detected, laser drive will be stopped forcibly and become single fault detection circuit. Meanwhile, the condition when single fault occurs is the same as initial power input, solutions (start-up circuit) of error detection for normal action when the circuit starts is required additionally.

For example of this safety circuit, please refer to application (5). When abnormality occurs, ELM742B, the comparator will detect the error, the latch which is composed by ELM7SU04BW will be turned reversely, and ELM33405CA, P-ch MOS will be off and thus shut down the power. When comparison voltage of 3 comparators is under 0.9V of KLD, under 0.1V of AMD, and above 2.5V of CMP, it will be judged as abnormality by OR condition of the comparator and thus the power will be shut down. This circuit is only for reference use; confirmation of safety standard fit actions on actual application is still required.

Start-up circuit consists of time constant of R1 and C1. The ratio of disperse voltage of R3, R4, R5, R8 is required to be changed with power voltage. For best solution, ELM recommends using ELM742B as the voltage detector, ELM7SU04BW as the latch and ELM33405CA as the transistor.

This circuit is for reference use only; additional inspection of safety standard suitability is required.

It is possible to insert detection circuit as shown in circuit (2) and (3) in this circuit.

ELM185xB Laser Diode Driver

circuit (5)

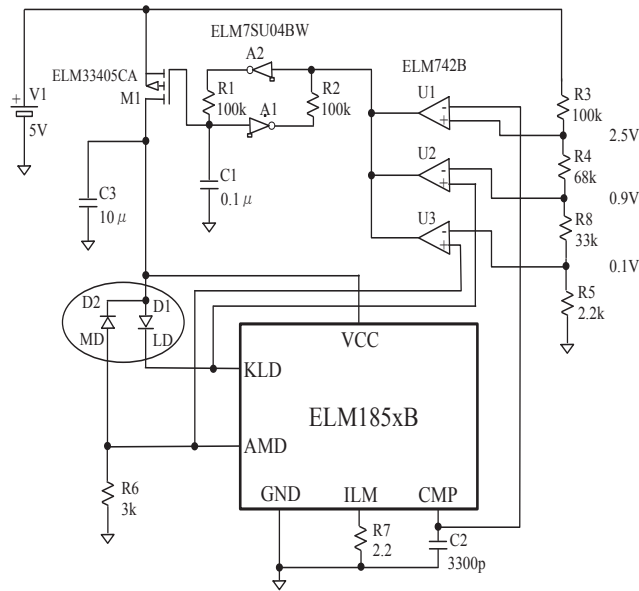

■ Application circuit example 4 (white LED constant current drive circuit)

Example of application of ELM185xBA as LED constant current drive current is shown as circuit (6).

This circuit is white LED drive circuit which is driven by constant current with external resistance of ILM. Since the voltage limit of KLD can reach 18V, it is possible to design several LEDs in series connection. The VCC voltage is controlled to be constant by internal Zener diode of ELM185xB.

circuit (6)

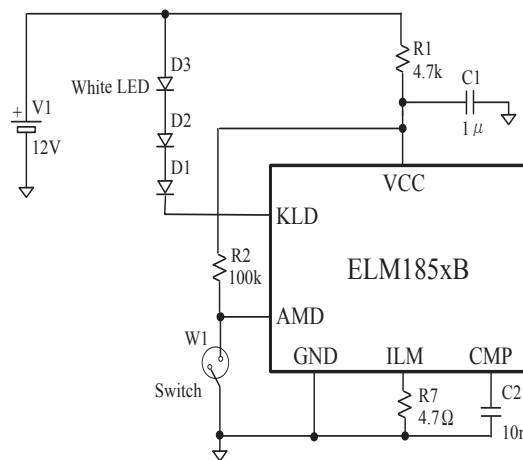

This circuit is designed by 3 series-connected white LEDs with power of 12V.

In this circuit, AMD is not used to control light feedback, but on/off only. Current control, which is constant current type, is monitored by the voltage of ILM. Capacitors of 0.1μF-0.01μF for anti-oscillation are connected to CMP. Resistance of R7 is set by constant current value; it will be 34mA under 4.7Ω. This value is calculated by the formula that $I_{out}=0.16/R7$. The power of ELM185xB will be lowered from 12V to 7V by R1 and internal Zener. Light will be turned on when the switch of W1 is ON, and be off when it is OFF.

ELM185xB Laser Diode Driver

■Notice

1. Safety standard

For different applications of laser diode, it is sometimes required that the application should obey the safety standard which is ruled by the law. Please make complete confirmation about which safety or law should be obeyed while designing the circuit. ELM185xB drives laser diode by the conditions which is set by external circuit; please confirm the actual output of light by instruments such as light power meter.

2. Laser diode damaged caused by surge voltage

Laser diode can be easily damaged by static or surge voltage when the power is turned on/off because of its low surge resistance. ELM185xB includes Zener for absorption of surge; for best protection, ELM recommends connecting ELM185xB and laser diode in the shortest distance.

connection in shortest distance

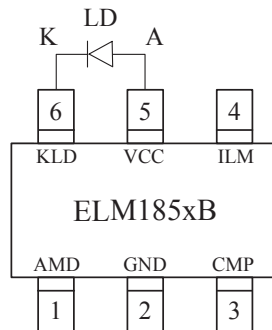

■Applicable laser diode modules

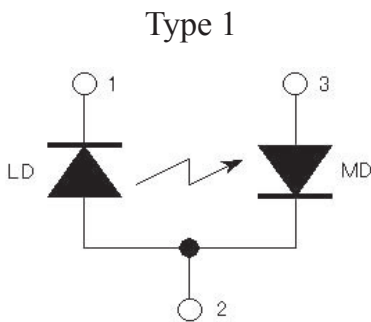

- 1 : LD cathode
- 2 : LD anode, MD cathode
- 3 : MD anode

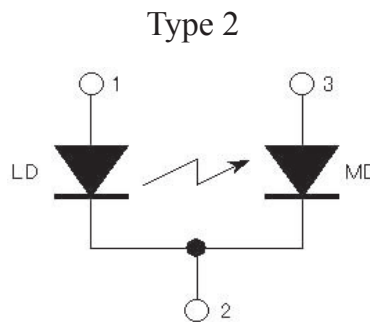

- 1 : LD anode
- 2 : LD cathode, MD cathode
- 3 : MD anode

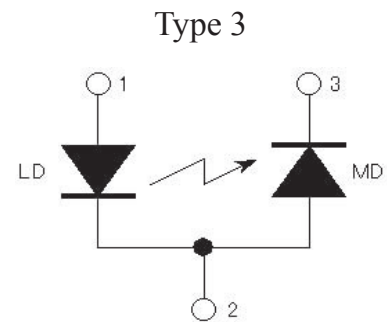

- 1 : LD anode
- 2 : LD cathode, MD anode
- 3 : MD cathode

It is possible to connect separate LD and MD to ELM185xB.

When connecting different LDMs other than these 3 types, additional parts are required.

ELM185xB Laser Diode Driver

Electrical characteristics

1. Icc consumption current

characteristics of power voltage vs. consumption current

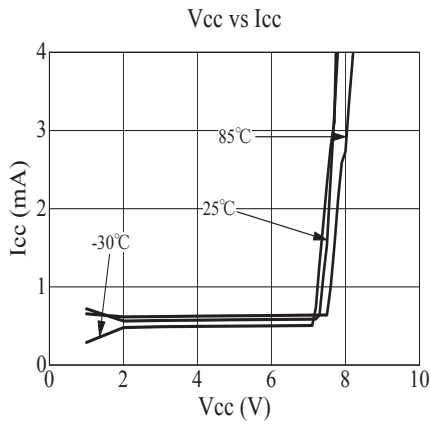

Icc consumption current test circuit

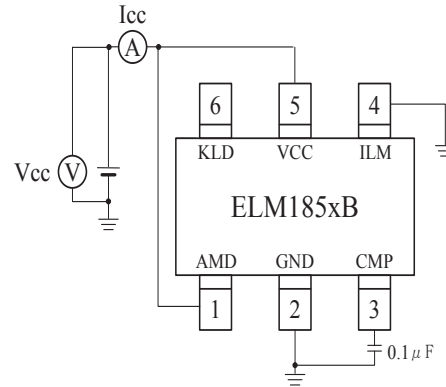

2. Vamd standard voltage

power voltage vs. AMD standard voltage

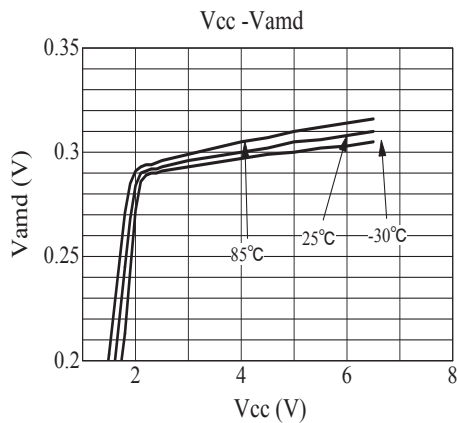

Vamd standard voltage test circuit

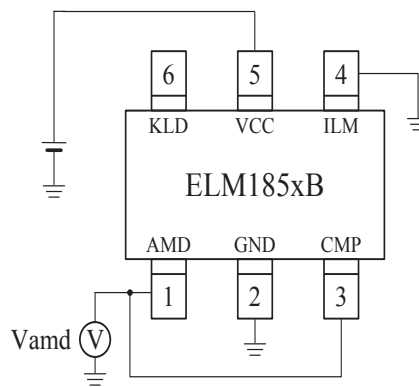

3. Ikld constant current

KLD output current voltage characteristics

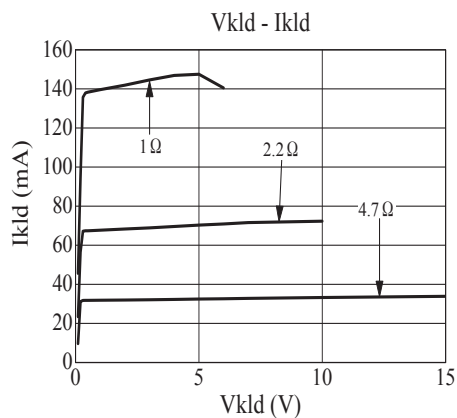

Ikld constant current test circuit

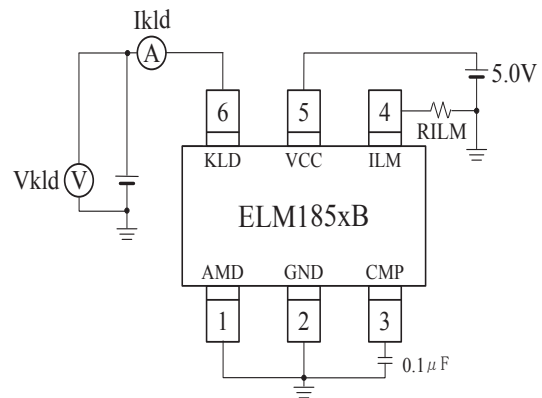

* When V_{kld} , I_{kld} are large, protection circuit operates according to the heat generation of IC; the limit will be determined by heat characteristic of actual assembly.