

## Features

- Ultra small package: 0.6x0.3x0.3mm
- Ultra low capacitance: 0.2 pF typical
- Ultra low leakage: nA level
- Low operating voltage: 5V
- Low clamping voltage
- 2-pin leadless package
- Complies with following standards:
  - - IEC 61000-4-2 (ESD) immunity test  
Air discharge: ±18kV  
Contact discharge: ±12kV
  - - IEC61000-4-5 (Lightning) 3A (8/20 μs)
- These are Pb-Free Devices
- Response Time is Typically < 1 ns

## Mechanical Characteristics

- Package: DFN0603-2 (0201)
- Lead Finish: Matte Tin
- Case Material: "Green" Molding Compound.
- Moisture Sensitivity: Level 3 per J-STD-020
- Terminal Connections: See Diagram Below

## Applications

- Cellular Handsets and Accessories
- Personal Digital Assistants
- Notebooks and Handhelds
- Portable Instrumentation
- Digital Cameras
- Peripherals

## Ordering Information

Part Number	Qty per Reel	Reel Size
TPESD112-B1-02ELS	10000 or 15000	7"

## Dimensions and Pin Configuration

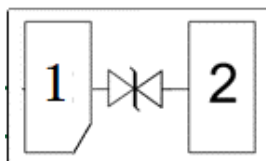

**Absolute Maximum Ratings** (T<sub>amb</sub>=25°C unless otherwise specified)

Parameter	Symbol	Value	Unit
Peak Pulse Power (8/20μs)	Ppk	70	W
Peak Pulse Current (8/20μs)	I <sub>pp</sub>	3	A
ESD per IEC 61000-4-2 (Air)	V <sub>ESD</sub>	±18	kV
ESD per IEC 61000-4-2 (Contact)		±12	
Operating Temperature Range	T <sub>J</sub>	-55 to +125	°C
Storage Temperature Range	T <sub>stg</sub>	-55 to +150	°C

**Electrical Characteristics** (T<sub>A</sub>=25°C unless otherwise specified)

Parameter	Symbol	Min	Typ	Max	Unit	Test Condition
Reverse Working Voltage	V <sub>RWM</sub>			5	V	
Breakdown Voltage	V <sub>BR</sub>	6	7.5	8.6	V	I <sub>T</sub> = 1mA
Reverse Leakage Current	I <sub>R</sub>			0.07	μA	V <sub>RWM</sub> = 5V
Clamping Voltage	V <sub>C</sub>			12	V	I <sub>pp</sub> =1A(8x 20us pulse)
Clamping Voltage	V <sub>C</sub>			20	V	I <sub>pp</sub> =3A(8x 20us pulse)
Junction Capacitance	C <sub>J</sub>		0.2	0.25	pF	V <sub>R</sub> = 0V, f = 1MHz

**Typical Performance Characteristics ( $T_A=25^\circ\text{C}$  unless otherwise Specified)**

Fig1. 8/20 $\mu\text{s}$  Pulse Waveform

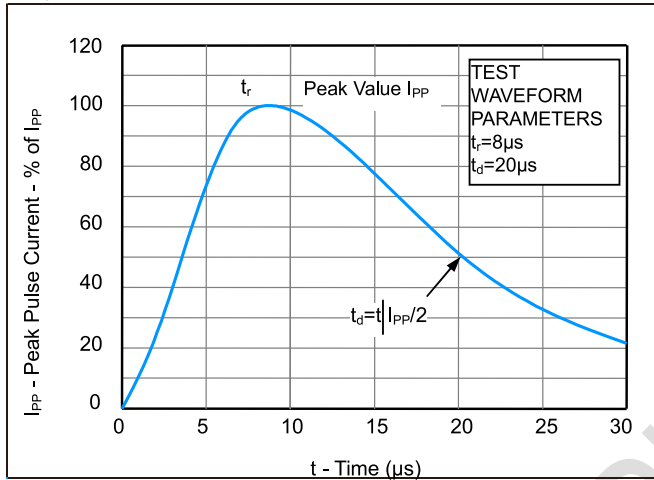

Fig2. ESD Pulse Waveform (according to IEC 61000-4-2)

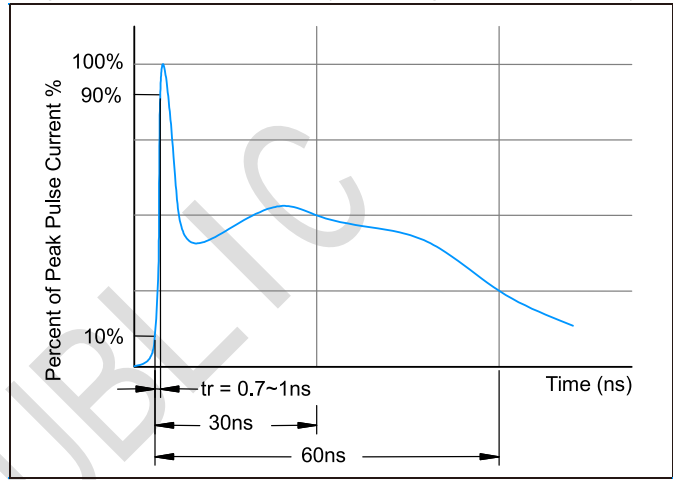
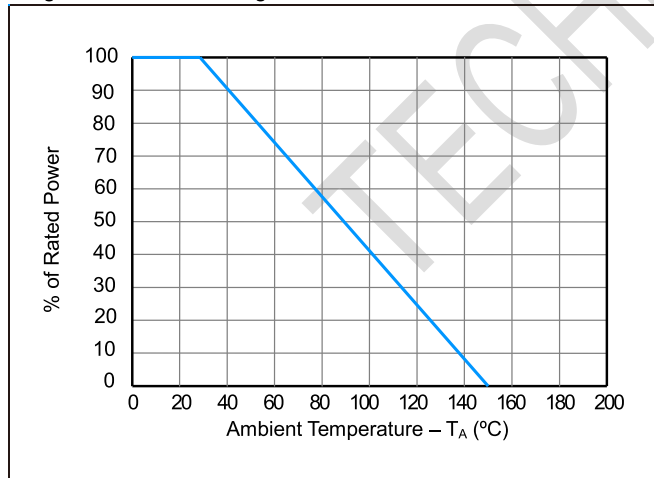
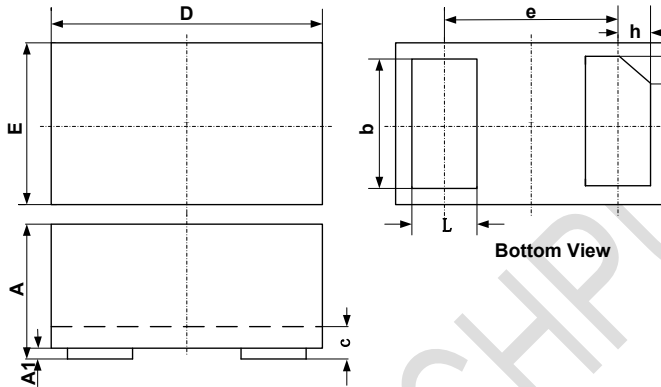

Fig3. Power Derating Curve



**DFN0603-2 Package Outline Drawing (0201)**



SYM	DIMENSIONS		
	MILLIMETERS		
	MIN	NOM	MAX
A	0.230	0.300	0.330
A1	0.000	0.020	0.050
b	0.215	0.245	0.275
c	0.120	0.150	0.180
D	0.550	0.600	0.650
e	0.355 BSC		
E	0.250	0.300	0.350
L	0.160	0.190	0.220
h	0.079 BSC		

**Suggested Land Pattern**

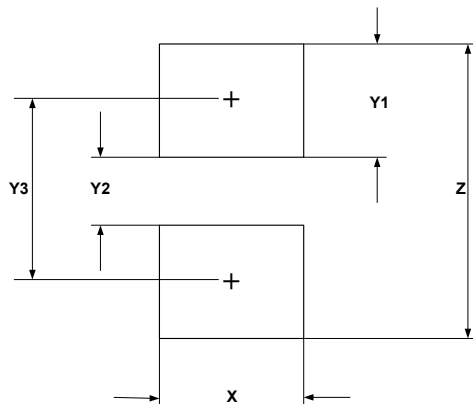

SYM	DIMENSIONS	
	MILLIMETERS	INCHES
X	0.30	0.012
Y1	0.25	0.010
Y2	0.15	0.006
Y3	0.40	0.016
Z	0.65	0.026