

PANEL CUTOUT

| PANEL THICKNESS | X |
|-----------------|------|
| 0.75 - 1.25 | 19.2 |
| 1.25 - 2.00 | 19.4 |
| 2.00 - 3.00 | 19.6 |

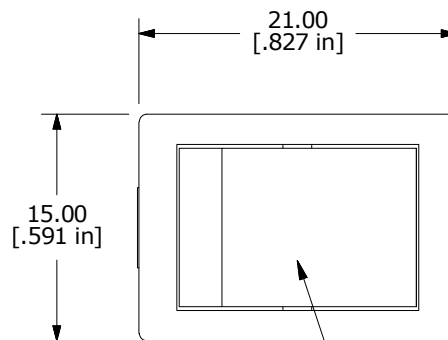

▲ LENS COLOR: GREEN

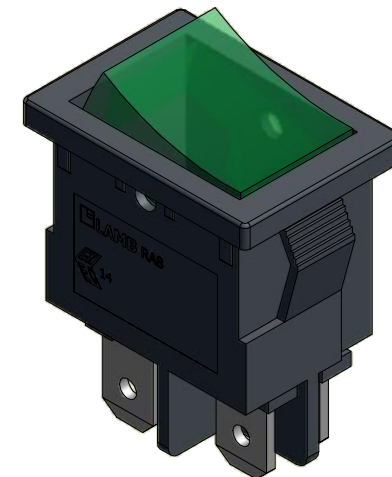

| SWITCH FUNCTION | |
|-----------------|-----------|
| POS. 1 | POS. 2 |
| | |
| OFF | ON |
| OPEN | 1-1a,2-2a |

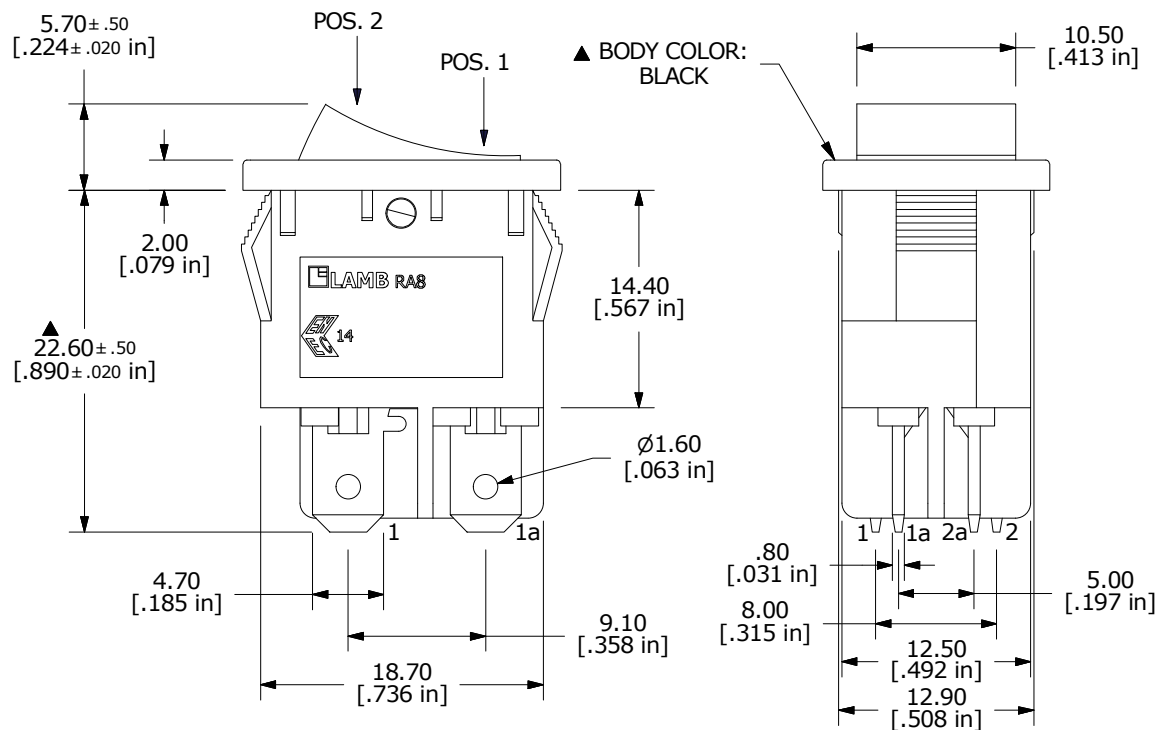
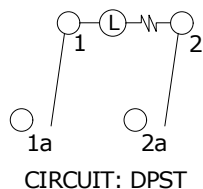

NOTE:

1. DIMENSIONS IN MM [INCH]
2. GENERAL TOLERANCE: X.X = ± 0.4
X.XX = ± 0.25
3. TERMINAL NUMBERS FOR REF ONLY
4. CONTACT MATERIAL: SILVER
5. CONTACT RATINGS: 10A @ 125VAC [UR, cUR]
6(2)A 250V~ 1E4 T85 [ENEC]
6. CONTACT RESISTANCE: 35mΩ MAX. @ 50VAC
7. INSULATION RESISTANCE: 500MΩ MIN. @ 500VAC
8. DIELECTRIC STRENGTH: 1,500VAC FOR 1 MINUTE
9. ELECTRICAL LIFE: 6,000 CYCLES [UR, cUR]
10,000 CYCLES [ENEC]
10. OPERATING TEMPERATURE: -20°C TO 105°C [UR, cUR]
-20°C TO 125°C [ENEC]
11. ▲ DENOTES CRITICAL PARAMETER
12. 2002/95/EC (ROHS) COMPLIANT
- ▲ 13. LAMP VOLTAGE: 250V



TITLE RA81231000-137

| | | | | |
|-----|--------|------------------------|-----------|----|
| A | 21835 | RELEASE FOR PRODUCTION | 4/20/2015 | MW |
| REV | PCR NO | DESCRIPTION | DATE | BY |

| | | | | |
|-------|-----------|----|------------------|-----|
| SCALE | DATE | DR | DWG | REV |
| 2:1 | 4/20/2015 | MW | 38-RA81231000137 | A |

THE INFORMATION CONTAINED IN THIS DOCUMENT IS PROPRIETARY TO E-SWITCH AND IS NOT TO BE COPIED OR TRANSFERRED