

Description

The AM4406/4406F are 2-phase, half-wave motor predrivers fabricated for fan motors. These ICs are equipped with lock shutdown and automatic restart functions. The lock shutdown function turns off the output current when the motor is under lock condition. And when the motor is unlocked, the ICs will automatically restart and allow DC fan to run.

In addition, the AM4406 and AM4406F have RD and FG functions respectively. The RD function is to detect the motor status and FG function enables frequency generation.

The AM4406/4406F are available in SOIC-8 package.

Pin Assignments

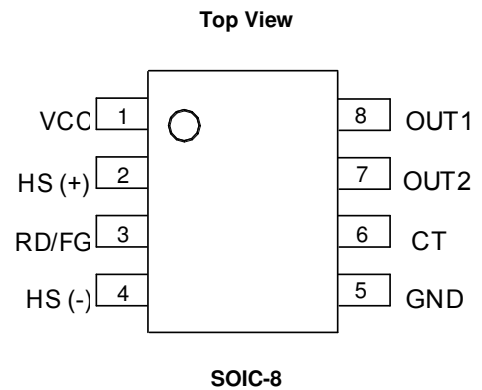

Features

- Hall Inputs with a Hysteresis
- Lock Shutdown and Automatic Restart
- Rotation Detection (RD) Output
- Frequency Generation (FG) Output
- Supply Voltage: 4 to 28V
- Output Current: 70mA Max.
- Operating Temperature: -40 to +95°C

Applications

- High Voltage, High Current Brushless DC Fan
- Power Supply and Switchboards
- Communications Facilities
- Industrial Equipment

Typical Applications Circuit

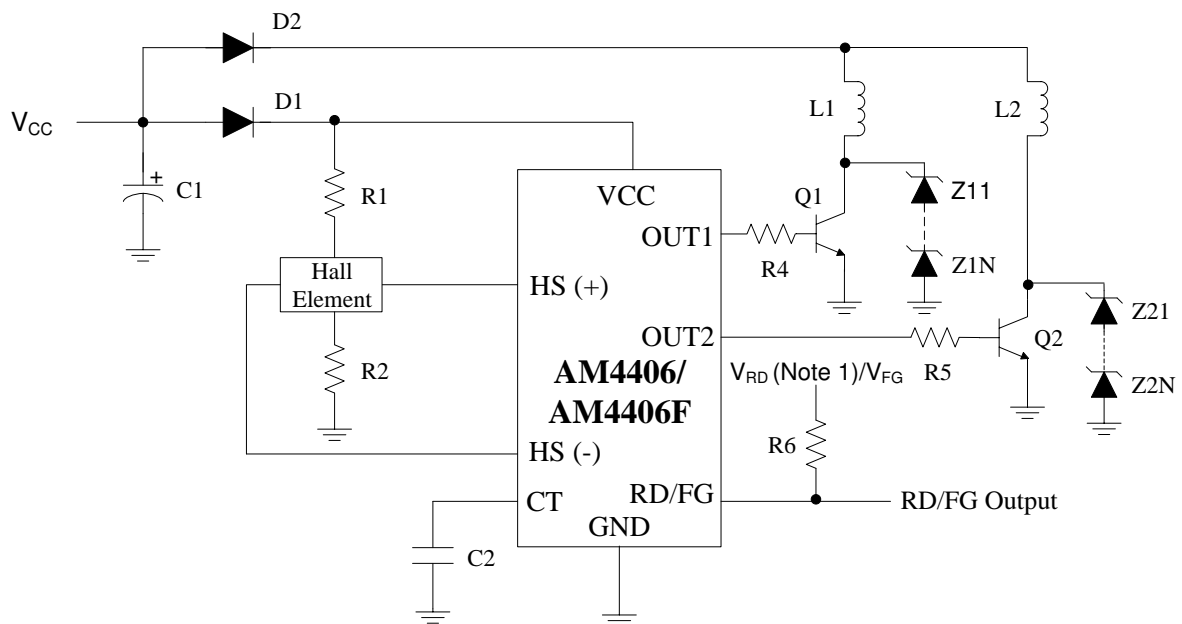

Note1: V_{RD} should be equal or smaller than V_{CC}

Pin Descriptions

Pin Number	Pin Name		Function
	AM4406	AM4406F	
1	VCC	VCC	Power supply
2	HS (+)	HS (+)	Hall input (+)
3	RD	FG	Rotation detection/Frequency generation
4	HS (-)	HS (-)	Hall input (-)
5	GND	GND	Ground
6	CT	CT	Timing capacitor
7	OUT2	OUT2	Driver output 2
8	OUT1	OUT1	Driver output 1

Functional Block Diagram

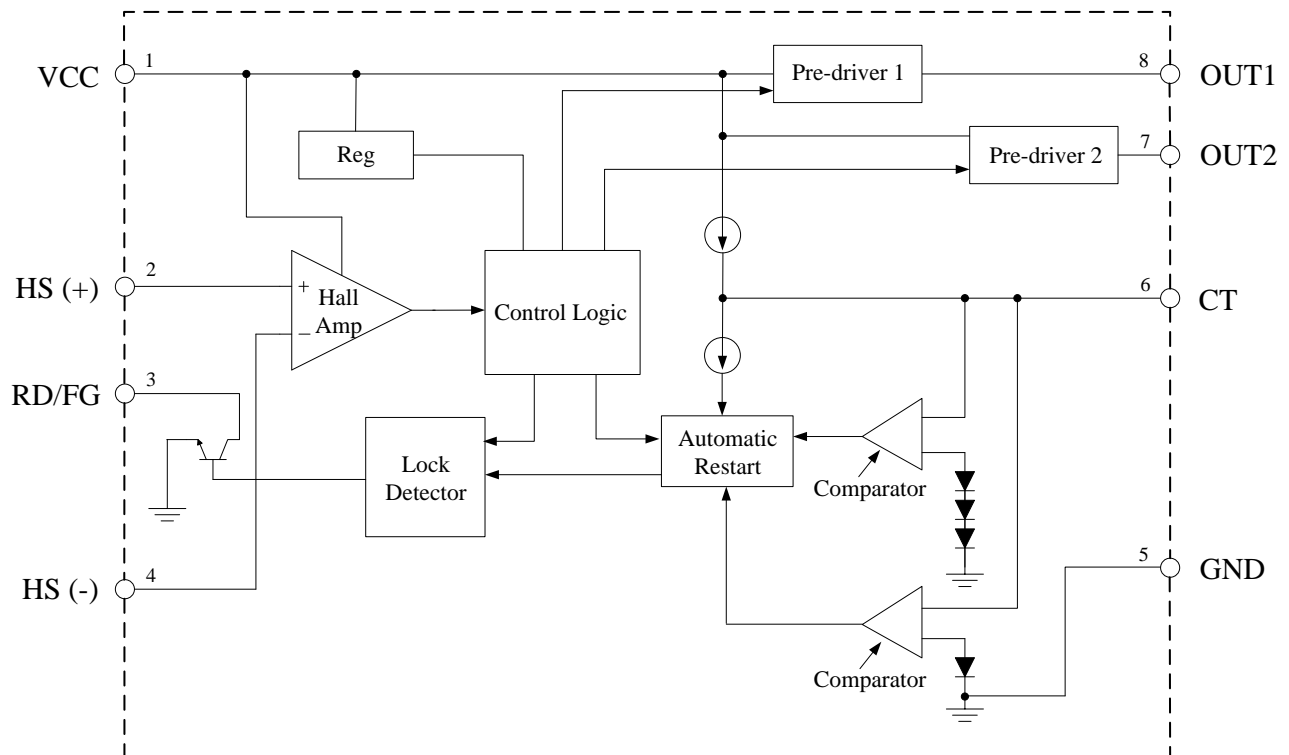

Absolute Maximum Ratings (Note 2)

Symbol	Parameter	Value	Unit
V _{CC}	Supply Voltage	30	V
I _{OUT}	Output Current	70	mA
P _D	Power Dissipation	550 (Note 3)	mW
T _{STG}	Storage Temperature Range	-55 to +125	°C
ESD	ESD (Human Body Model)	3000	V
ESD	ESD (Machine Model)	300	V

Note 2: Stresses greater than those listed under "Absolute Maximum Ratings" may cause permanent damage to the device. These are stress ratings only, and functional operation of the device at these or any other conditions beyond those indicated under "Recommended Operating Conditions" is not implied. Exposure to "Absolute Maximum Ratings" for extended periods may affect device reliability.

Note 3: Reduced by 5.5mW/°C when T_A is over +25°C.

Recommended Operating Conditions

Symbol	Parameter	Min	Max	Unit
V _{CC}	Supply Voltage	4	28	V
V _{HS (+)}	Hall Input Voltage (+) (Note 4)	1.0	V _{CC} -0.5	V
V _{HS (-)}	Hall Input Voltage (-) (Note 4)	1.0	V _{CC} -0.5	V
T _A	Operating Temperature	-40	+95	°C

Note 4: Hall input voltage range includes the amplitude of signal.

Electrical Characteristics ($V_{CC}=12V$, $T_A=+25^{\circ}C$, unless otherwise specified.)

Symbol	Parameter	Conditions	Min	Typ	Max	Unit
I_{CC}	Supply Current	No load	–	3.2	5.0	mA
$V_{HYS (+)}$	Hall Amplifier Input Hysteresis (+)	Zero to peak including offset and hysteresis	3	–	15	mV
$V_{HYS (-)}$	Hall Amplifier Input Hysteresis (-)	Zero to peak including offset and hysteresis	-3	–	-15	mV
I_{CHG}	CT Charge Current	$V_{CT}=1.5V$	2	3.45	5.25	μA
I_{DHG}	CT Discharge Current	$V_{CT}=1.5V$	0.35	0.8	1.45	μA
R_{CD}	CT Charge and Discharge Ratio	I_{CHG}/I_{DHG}	3	4.5	8	–
V_{CL}	CT Clamp Voltage	–	2.2	2.6	3	V
V_{CP}	CT Comparator Voltage	–	0.4	0.6	0.8	V
V_{OH1}	OUT1 High Level Voltage	$I_{OUT1}=10mA$	10	10.5	–	V
V_{OH2}	OUT2 High Level Voltage	$I_{OUT2}=10mA$	10	10.5	–	V
$V_{RD L}$	RD Output Low Level Voltage	$I_{RD}=5mA$	–	0.2	0.5	V
I_{RD}	RD Current Capacity	$V_{RD}=2V$	8	18	–	mA
V_{FGL}	FG Output Low Level Voltage	$I_{FG}=5mA$	–	0.2	0.5	V
I_{FG}	FG Current Capacity	$V_{FG}=2V$	8	18	–	mA

Performance Characteristics

Supply Current vs. Supply Voltage

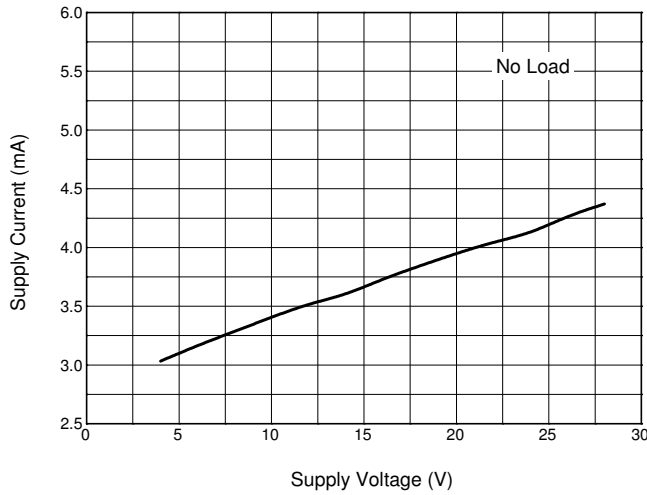

Output Voltage vs. Output Current

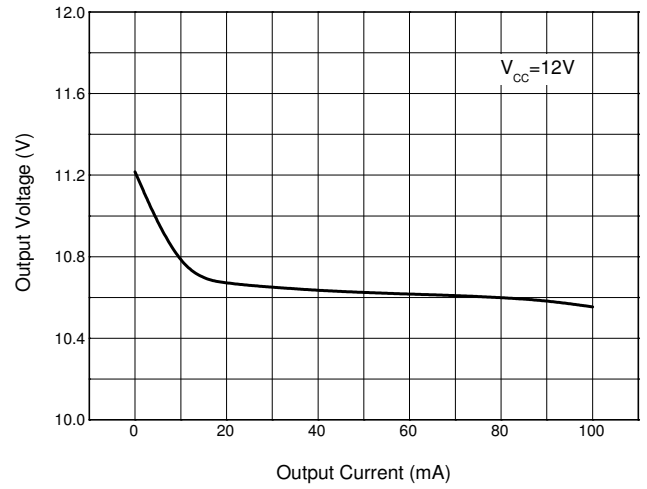

RD/FG Current vs. RD/FG Supply Voltage

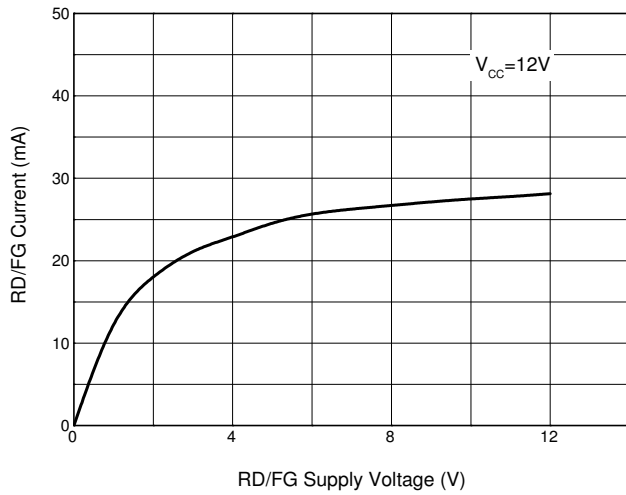

RD/FG Low Voltage vs. RD/FG Current

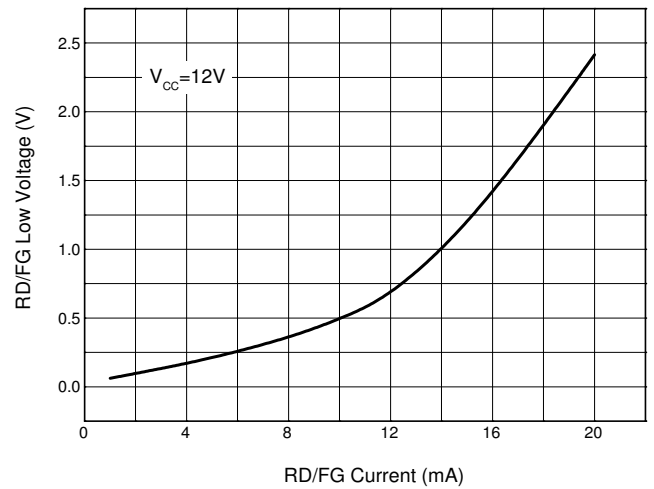

Power Dissipation vs. Ambient Temperature

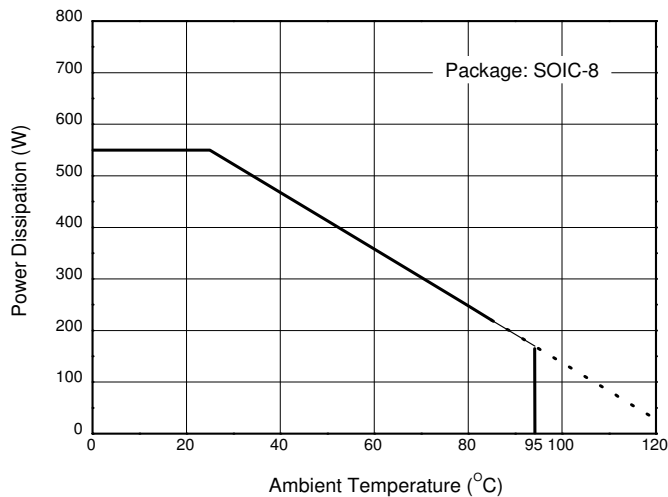

Operating Diagram

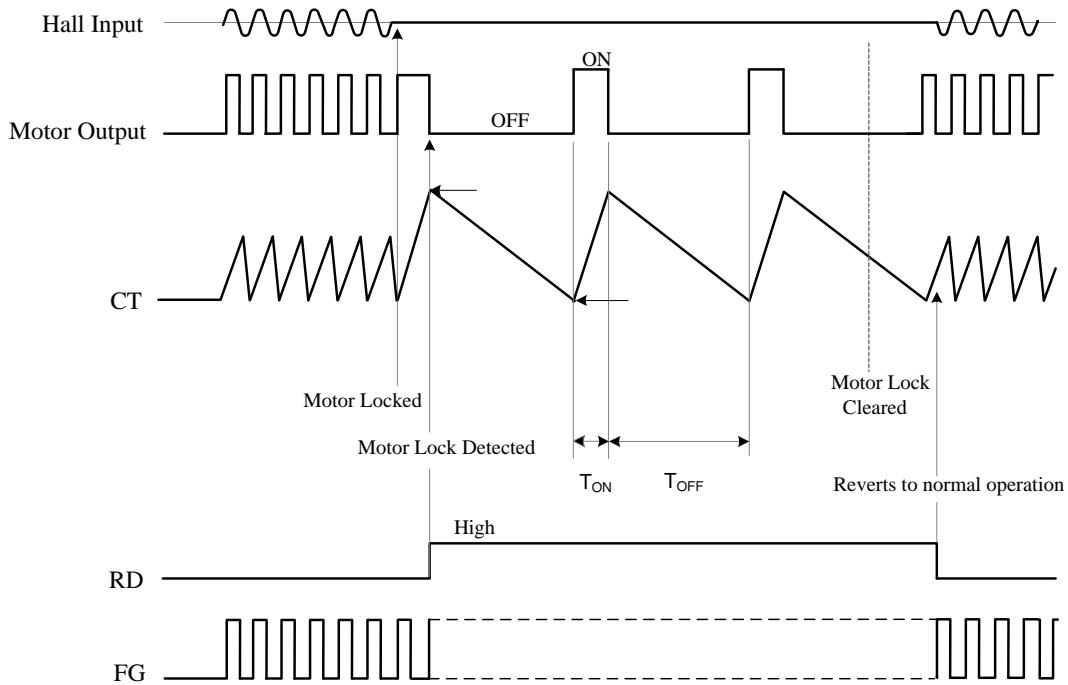

Note 5: Automatic restart is performed in the following manner. A motor lock condition is detected when the Hall signal stops switching. The output is ON when CT pin is being charged. C2 is the external capacitor of the CT pin. Output ON time and OFF time are determined by the capacitance of C2.

Note 6: RD pin is ON during normal operation, and OFF when the motor is locked. It is an open collector output pin.

$$T_{ON} = \frac{C2 * (V_{CL} - V_{CP})}{I_{CHG}} (Sec.)$$

$$T_{OFF} = \frac{C2 * (V_{CL} - V_{CP})}{I_{DHG}} (Sec.)$$

Note 7: The RD pin may maintain HIGH level for a few hundred milliseconds when the power is turned on.

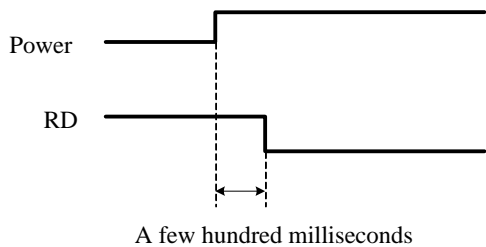

Ordering Information

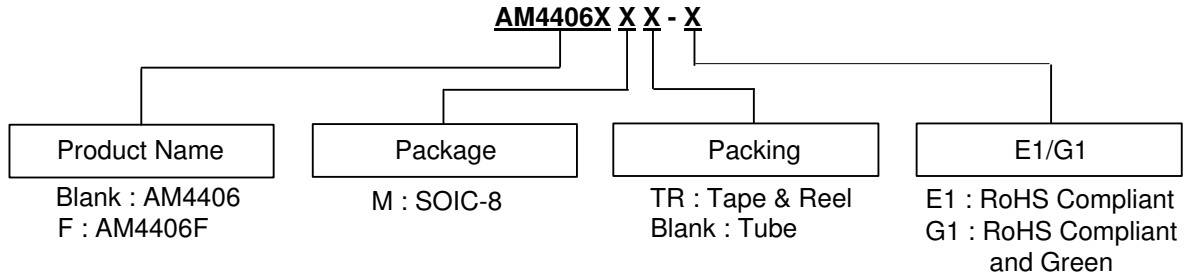

Package	Temperature Range	Part Number		Marking ID		Packing
		RoHS Compliant	RoHS Compliant and Green	RoHS Compliant	RoHS Compliant and Green	
SOIC-8	-40 to +95°C	AM4406M-E1	AM4406M-G1	AM4406M	AM4406M-G1	Tube
		AM4406MTR-E1	AM4406MTR-G1	AM4406M	AM4406M-G1	Tape & Reel
		-	AM4406FMTR-G1	-	AM4406FM-G1	Tape & Reel

Package Outline Dimensions (All dimensions in mm(inch).)

(1) Package Type: SOIC-8

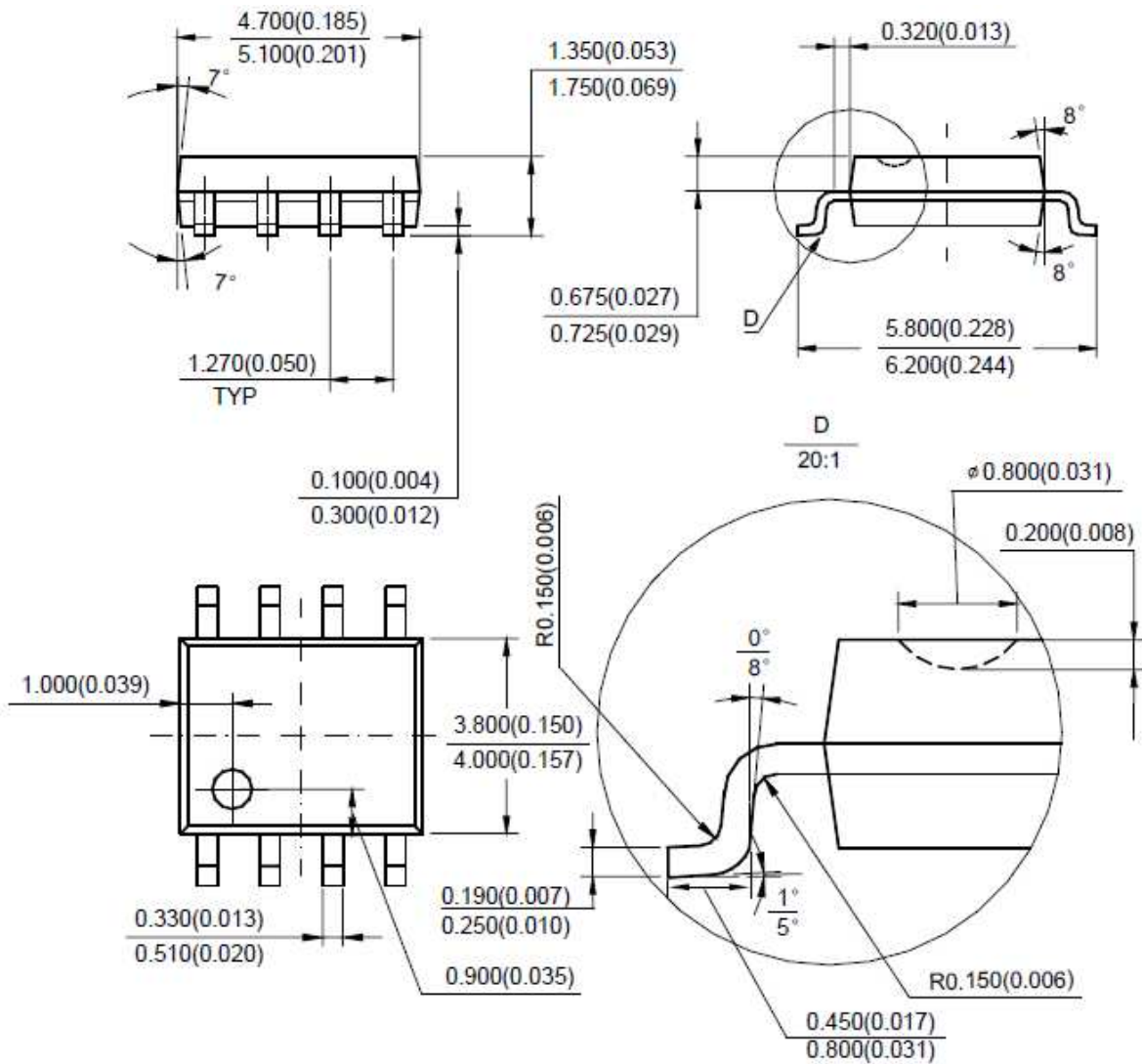

Note: Eject hole, oriented hole and mold mark is optional.

IMPORTANT NOTICE

DIODES INCORPORATED MAKES NO WARRANTY OF ANY KIND, EXPRESS OR IMPLIED, WITH REGARDS TO THIS DOCUMENT, INCLUDING, BUT NOT LIMITED TO, THE IMPLIED WARRANTIES OF MERCHANTABILITY AND FITNESS FOR A PARTICULAR PURPOSE (AND THEIR EQUIVALENTS UNDER THE LAWS OF ANY JURISDICTION).

Diodes Incorporated and its subsidiaries reserve the right to make modifications, enhancements, improvements, corrections or other changes without further notice to this document and any product described herein. Diodes Incorporated does not assume any liability arising out of the application or use of this document or any product described herein; neither does Diodes Incorporated convey any license under its patent or trademark rights, nor the rights of others. Any Customer or user of this document or products described herein in such applications shall assume all risks of such use and will agree to hold Diodes Incorporated and all the companies whose products are represented on Diodes Incorporated website, harmless against all damages.

Diodes Incorporated does not warrant or accept any liability whatsoever in respect of any products purchased through unauthorized sales channel. Should Customers purchase or use Diodes Incorporated products for any unintended or unauthorized application, Customers shall indemnify and hold Diodes Incorporated and its representatives harmless against all claims, damages, expenses, and attorney fees arising out of, directly or indirectly, any claim of personal injury or death associated with such unintended or unauthorized application.

Products described herein may be covered by one or more United States, international or foreign patents pending. Product names and markings noted herein may also be covered by one or more United States, international or foreign trademarks.

This document is written in English but may be translated into multiple languages for reference. Only the English version of this document is the final and determinative format released by Diodes Incorporated.

LIFE SUPPORT

Diodes Incorporated products are specifically not authorized for use as critical components in life support devices or systems without the express written approval of the Chief Executive Officer of Diodes Incorporated. As used herein:

A. Life support devices or systems are devices or systems which:

1. are intended to implant into the body, or
2. support or sustain life and whose failure to perform when properly used in accordance with instructions for use provided in the labeling can be reasonably expected to result in significant injury to the user.

B. A critical component is any component in a life support device or system whose failure to perform can be reasonably expected to cause the failure of the life support device or to affect its safety or effectiveness.

Customers represent that they have all necessary expertise in the safety and regulatory ramifications of their life support devices or systems, and acknowledge and agree that they are solely responsible for all legal, regulatory and safety-related requirements concerning their products and any use of Diodes Incorporated products in such safety-critical, life support devices or systems, notwithstanding any devices- or systems-related information or support that may be provided by Diodes Incorporated. Further, Customers must fully indemnify Diodes Incorporated and its representatives against any damages arising out of the use of Diodes Incorporated products in such safety-critical, life support devices or systems.

Copyright © 2018, Diodes Incorporated

www.diodes.com