



PARA LIGHT ELECTRONICS CO., LTD.

4F, No.1, Lane 93, Chien Yi Road, Chung Ho City, Taipei, Taiwan, R.O.C.

Tel: 886-2-2225-3733

Fax: 886-2-2225-4800

E-mail: para@para.com.tw

<http://www.para.com.tw>

DATA SHEET

PART NO. : B-2233SRD

REV : A / 2

CUSTOMER'S APPROVAL : _____

DCC : _____

DRAWING NO. : DS17080006

DATE : 20150829

Page : 1

PACKAGE DIMENSIONS

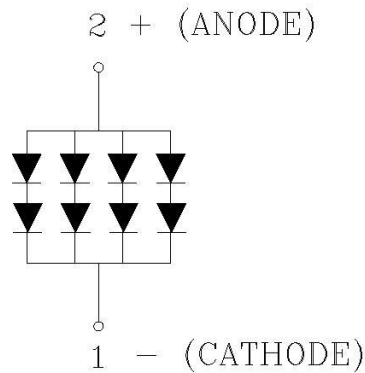
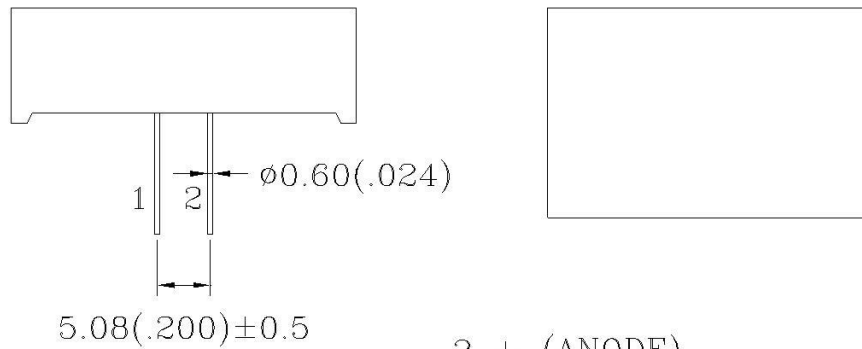
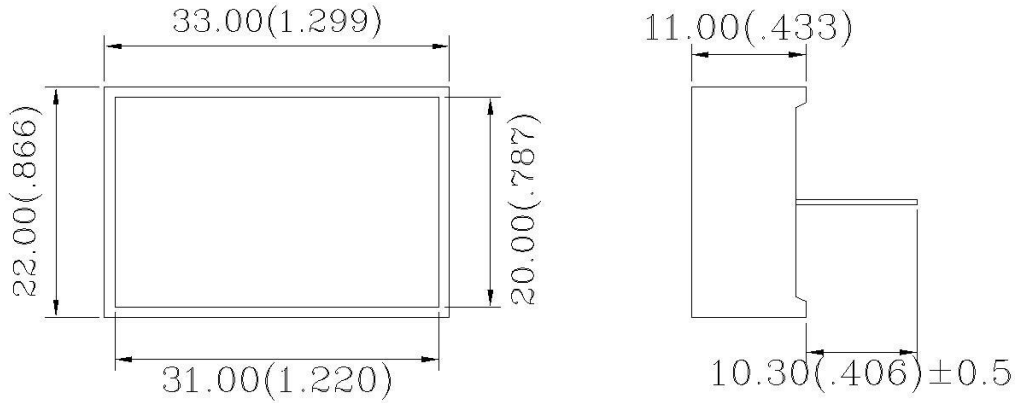

NOTES : 1. All dimensions are in millimeters. (inches)
2. Tolerance is $\pm 0.25(0.010)$ unless otherwise specified.



20.00mm x 31.00mm SQUARE LIGHT BAR

B-2233SRD

REV:A / 2

FEATURES

20.00 x 31.00mm SQUARE LIGHT BAR
LOW POWER REQUIREMENT
CAN BE USED WITH PANEL AND LEGEND MOUNT
SUITABLE FOR MULTIPLEX OPERATION
EASY MOUNTING ON P.C.B
Pb FREE PRODUCTS
ROHS COMPLIANCE
RED SEGMENTS

Raw Material : GaAlInP/GaAs

ABSOLUTE MAXIMUM RATING : (Ta = 25°C)

SYMBOL	PARAMETER	SUPER RED	UNIT
PD	Power Dissipation Per Bar	530	mW
VR	Reverse Voltage Per Bar	10	V
IAF	Continuous Forward Current Per Bar	120	mA
—	Derating Linear From 25°C Per Bar	0.4	mA/°C
Topr	Operating Temperature Range	-35°C to 85°C	
Tstg	Storage Temperature Range	-35°C to 85°C	

ELECTROOPTICAL CHARACTERISTICS : (Ta = 25°C)

SYMBOL	PARAMETER	TEST CONDITION	MIN.	TYP.	MAX.	UNIT
VF	Forward Voltage , Per Bar	IF = 80mA		3.6	4.4	V
IR	Reverse Current , Per Bar	VR = 10V			100	A
λP	Peak Emission Wavelength	IF = 20mA		660		nm
λD	Dominant Wavelength	IF = 20mA		643		nm
λ	Spectral Line Half-Width	IF = 20mA		20		nm
IV	Luminous Intensity Per Bar	IF = 40mA	12.0	30.0		mcd

FORWARD CURRENT Vs.
FORWARD VOLTAGE

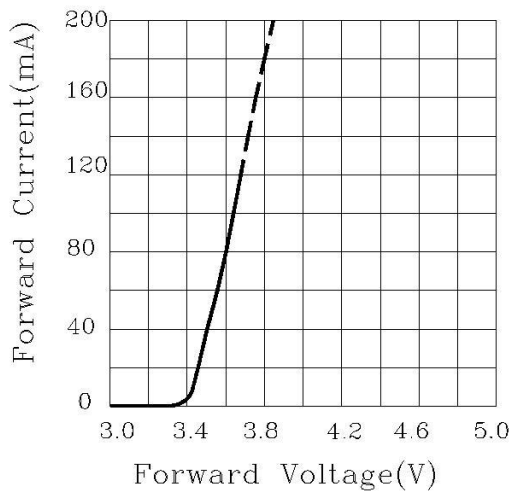

LUMINOUS INTENSITY Vs.
FORWARD CURRENT

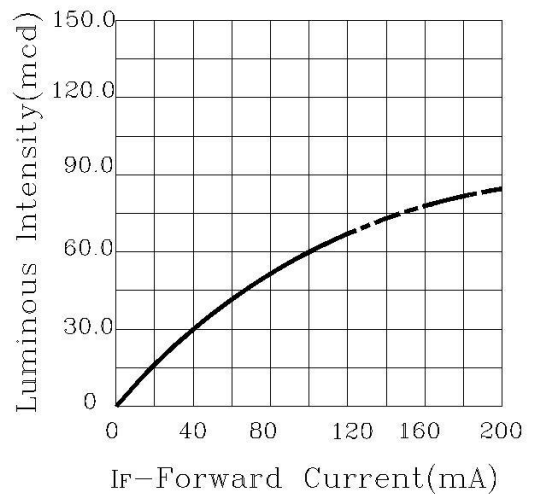

FORWARD CURRENT
DERATING CURVE

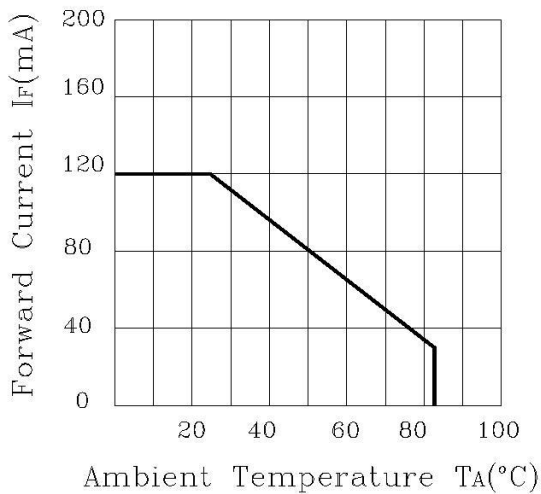

LUMINOUS INTENSITY Vs.
AMBIENT TEMPERATURE

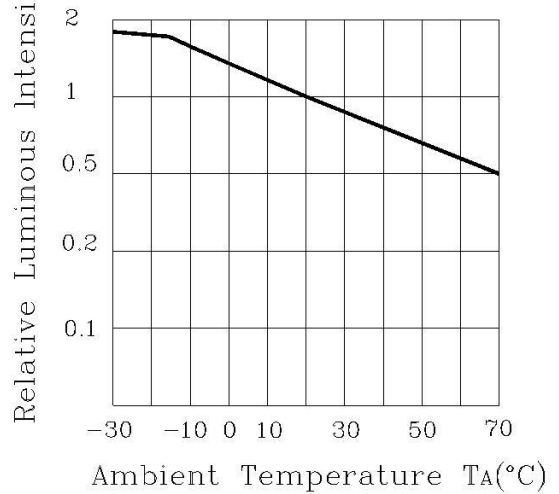

SOLDERING

METHOD	SOLDERING CONDITIONS	REMARK
DIP SOLDERING	Bath temperature: 260 max Immersion time: with 5 sec	Solder no closer than 2mm from the base of the package Using soldering flux," RESIN FLUX" is recommended.
SOLDERING IRON	Soldering iron: 30W or smaller Temperature at tip of iron: 260 or lower Soldering time: within 5 sec.	During soldering, take care not to press the tip of iron against the PIN. (To prevent heat from being transferred directly to the PIN.)

1) When soldering the PIN of Display in a jig that the package is fixed with a panel (See fig.1), be careful not to stress the PIN with iron tip. When soldering Display in a condition that the package is fixed with a panel, be careful not to cling and stress the surface of Display on the panel to avoid damaging the Display.

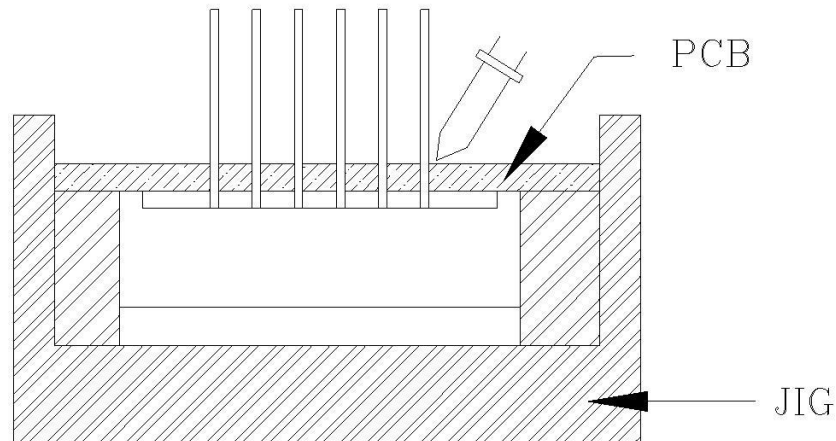

Fig.1

Regarding solution in the tinning oven for producttinning, compound subsolution made of tin & copper and silver is proposed with the temperature of Celsius 260. The proportion of the alloyed solution is tin 95.5: copper 3.5: silver 0.5 by percentage. The time of tinning is constantly 3 seconds.