

PLEASE CHECK WWW.MOLEX.COM FOR LATEST PART INFORMATION

Part Number: [0643183019](#)
Status: **Active**
Overview: [cmc connectors](#)
Description: .635mm (.025"), 1.50mm (.059"), 2.80mm (.110"), Power CMC Connector, 28 Circuits, Right Wire Output, Brown Coding, Mat Sealed

Documents:

[3D Model](#) [Product Specification PS-64318-001 \(PDF\)](#)
[Drawing \(PDF\)](#) [RoHS Certificate of Compliance \(PDF\)](#)
[Application Specification \(PDF\)](#)

General

Product Family	Crimp Housings
Series	64318
Comments	* Current tested on a fully loaded connector, current for temperature increase of 40°C. Current max = 21.0A for 2.8mm Terminal (5.0mm ² wire), 12.0A for 1.5mm Terminal (2.0mm ² wire), 2.5A for 0.635mm Terminal(0.75mm ² wire) *
More Detailed Tech Information	Sealed, high-density, power, modular connecting system for Power Train and Body Electronics applications in cars, trucks, busses
Overview	cmc connectors
Product Name	CMC

Physical

Circuits (maximum)	28
Circuits Detail	5x 2.8mm, 5 x 1.5mm, 18 x 0.635mm terminals
Color - Resin	Brown
Gender	Female
Glow-Wire Compliant	No
Keying to Mating Part	Yes
Lock to Mating Part	Yes
Material - Resin	Polyester
Number of Rows	3
Packaging Type	Carton
Panel Mount	No
Pitch - Mating Interface (in)	0.100 In, 0.138 In, 0.266 In
Pitch - Mating Interface (mm)	2.54 mm, 3.50 mm, 6.75 mm
Polarized to Mating Part	Yes
Stackable	No
Temperature Range - Operating	-40°C to +125°C

Electrical

Current - Maximum per Contact	12A, 2.5A, 21A
-------------------------------	----------------

Material Info

Reference - Drawing Numbers

Application Specification	AS-64318-001
Packaging Specification	PK-98994-001
Product Specification	PS-64318-001
Sales Drawing	SD-64318-001, SD-98994-001

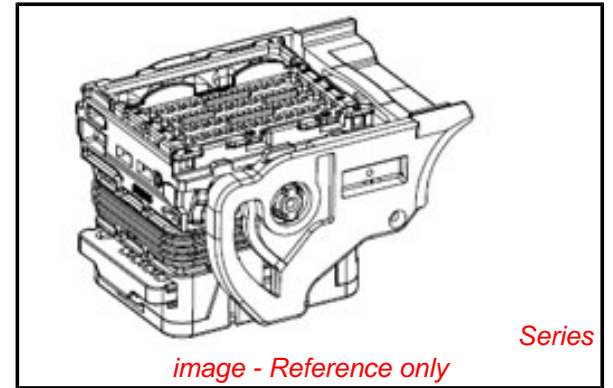

EU RoHS

ELV and RoHS Compliant
REACH SVHC
 Not Reviewed
Halogen-Free Status

China RoHS



Not Reviewed

Need more information on product environmental compliance?

Email productcompliance@molex.com
 For a multiple part number RoHS Certificate of Compliance, [click here](#)

Please visit the [Contact Us](#) section for any non-product compliance questions.

Search Parts in this Series

[64318Series](#)

Mates With

28 Circuit CMC Header Coming Soon - Please Contact Molex for Details

Use With

Female Terminals [64322](#) CP 0.635 (.025"), [64323](#) CP 1.5 (.059") Link: [64324](#) CP 2.8 (.110") . Circuit Way Plugs [643251010](#) , [643251023](#) , [643251091](#). CMC Wire Cap [643201301](#)

PLEASE CHECK WWW.MOLEX.COM FOR LATEST PART INFORMATION

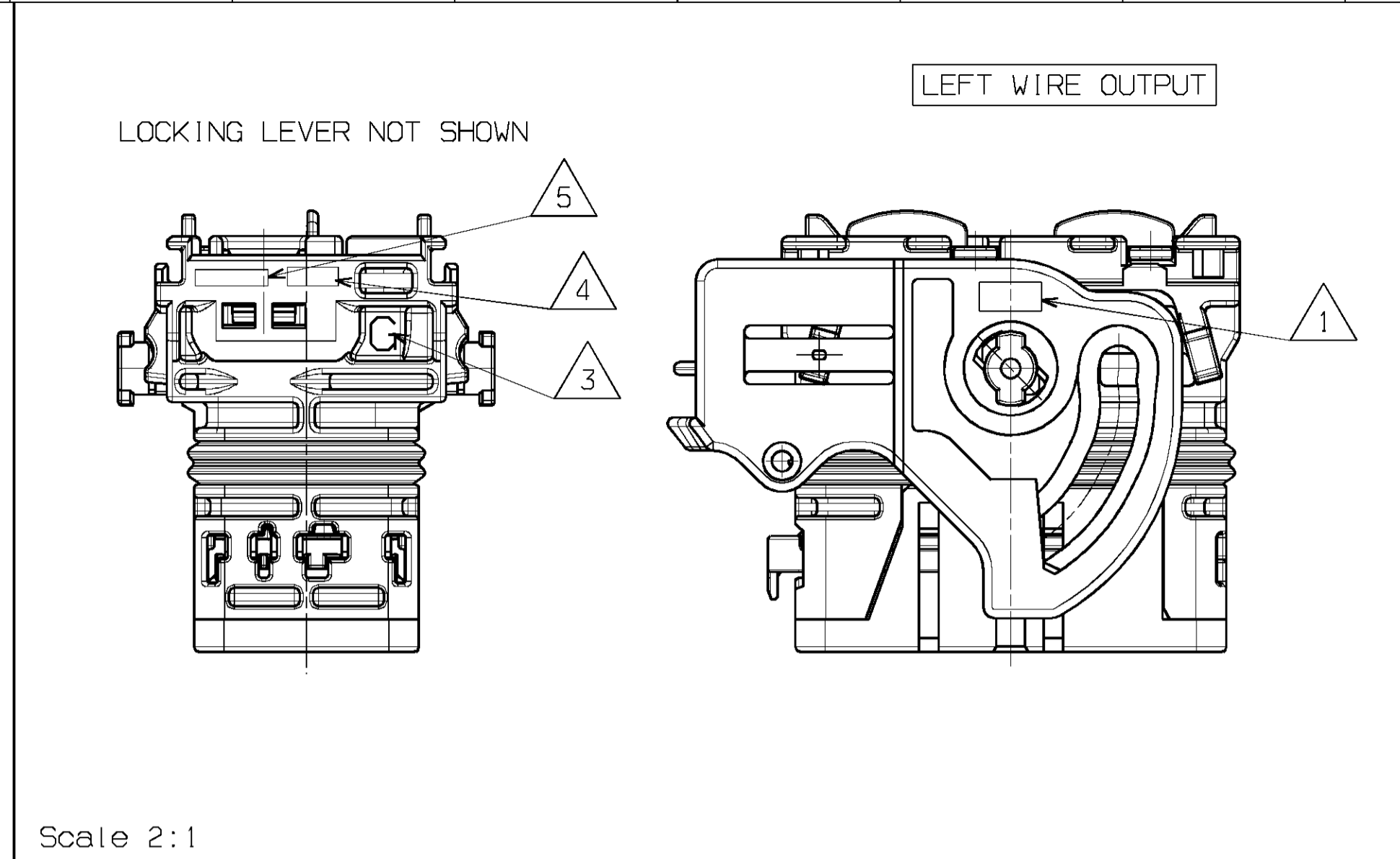
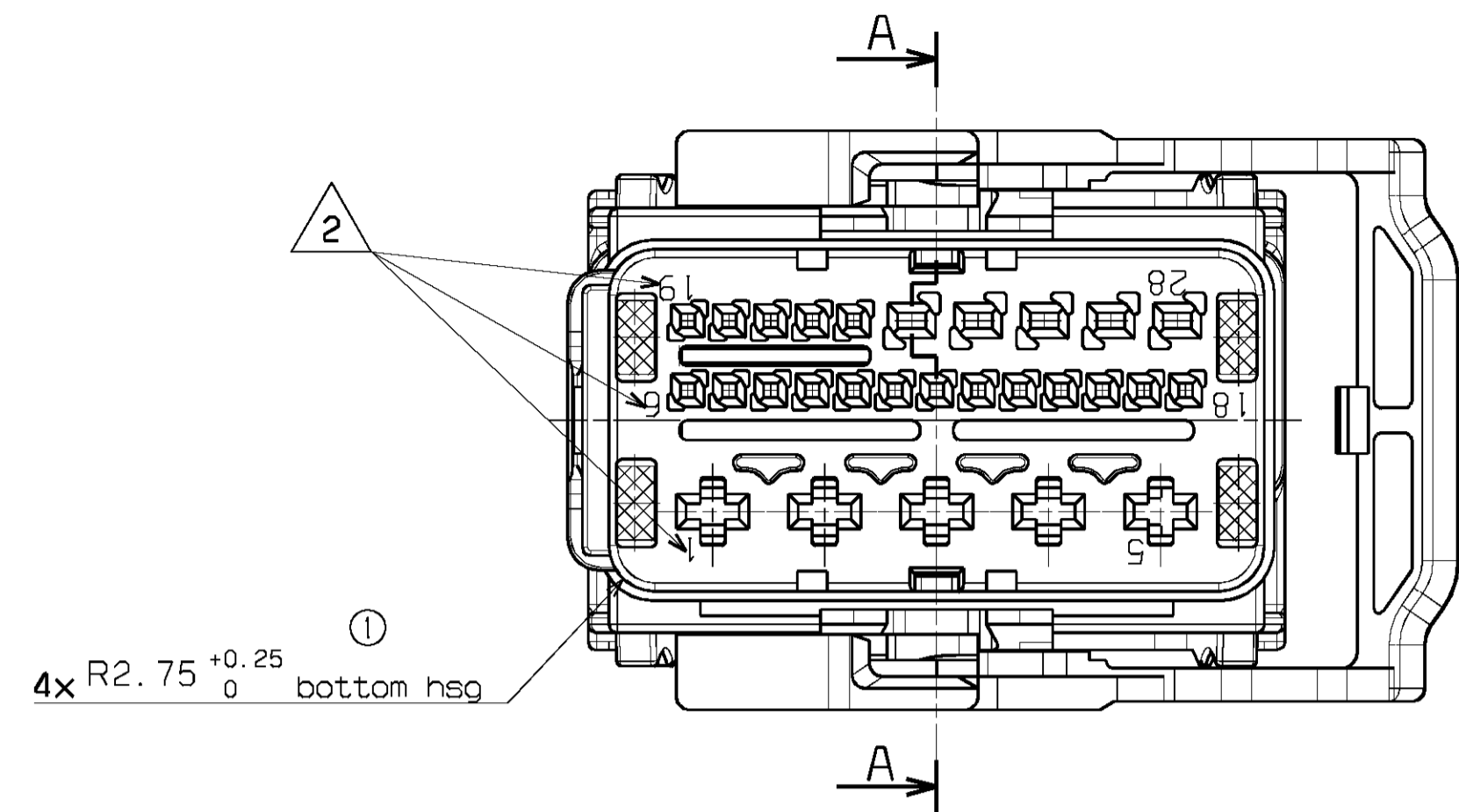

LEFT WIRE OUTPUT

MATERIAL NUMBER	COLOR
0643181011	BLACK
0643181018	GREY
0643181019	BROWN

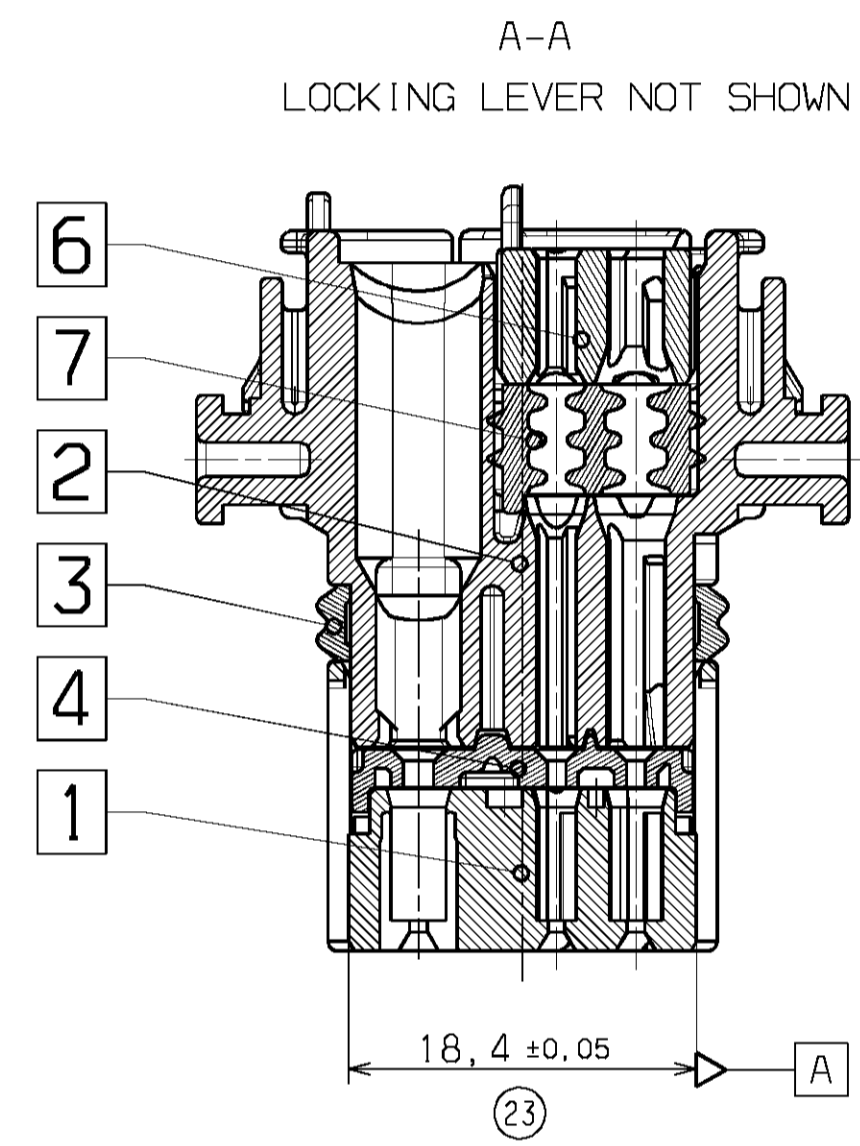
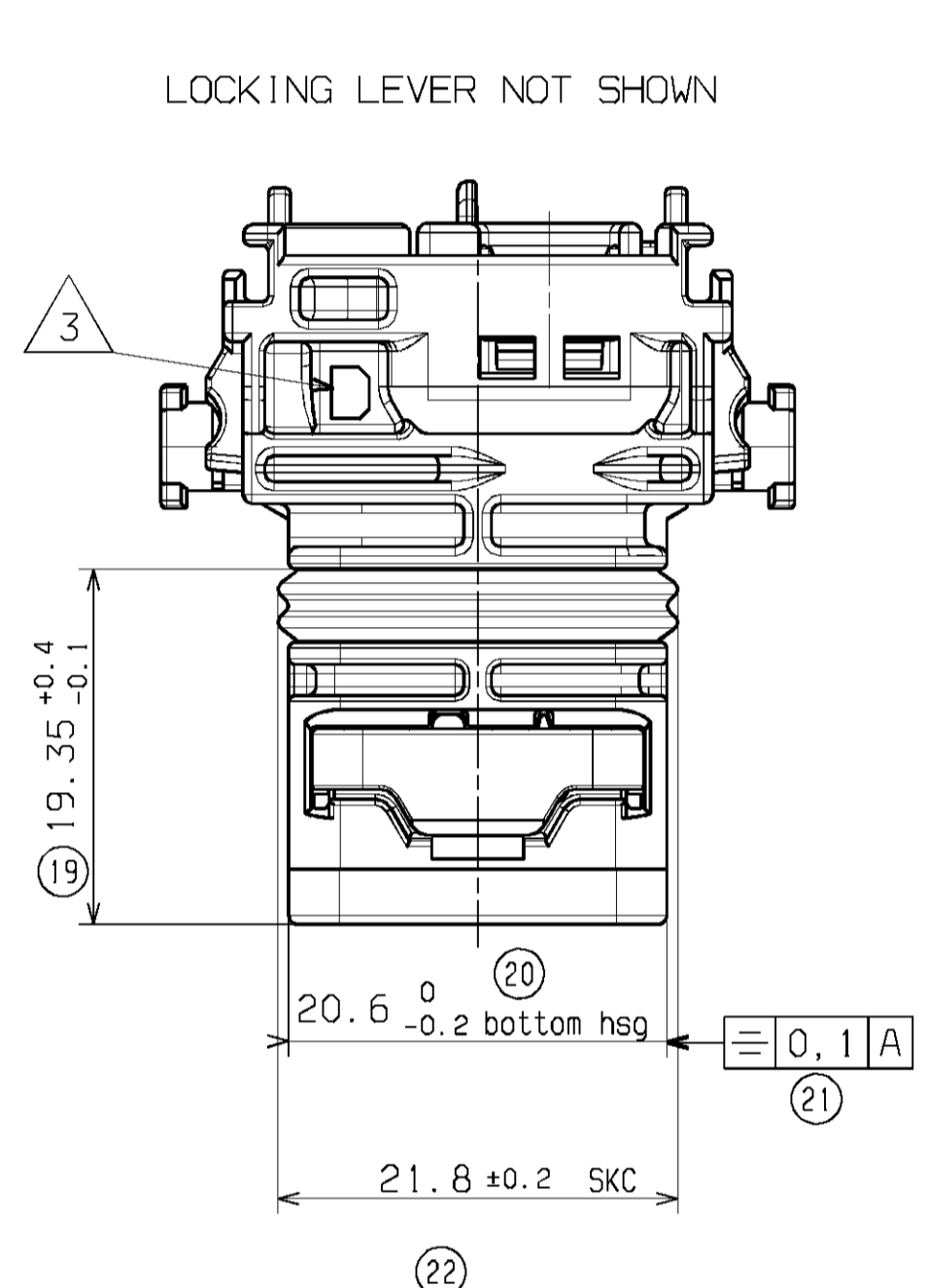
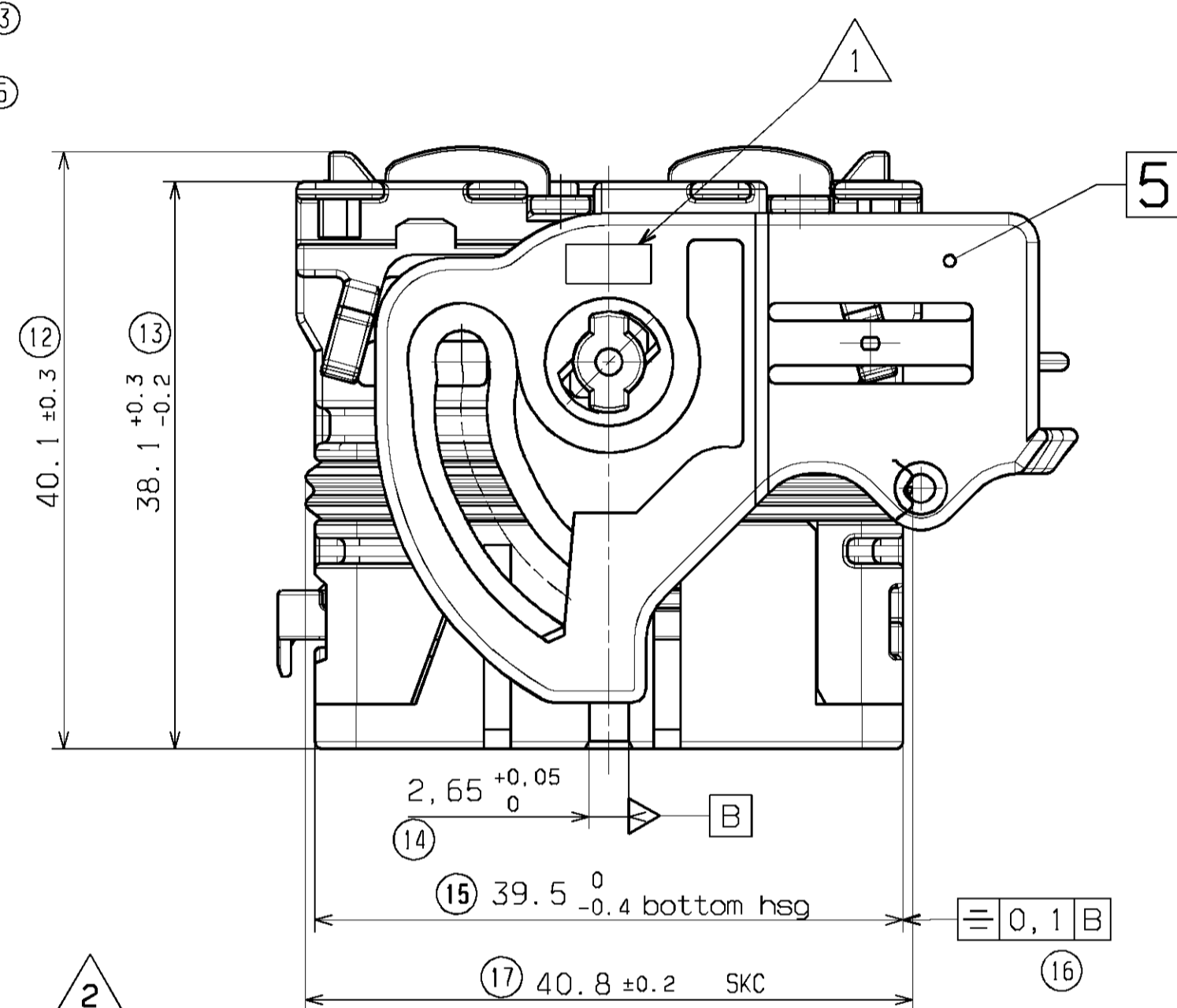
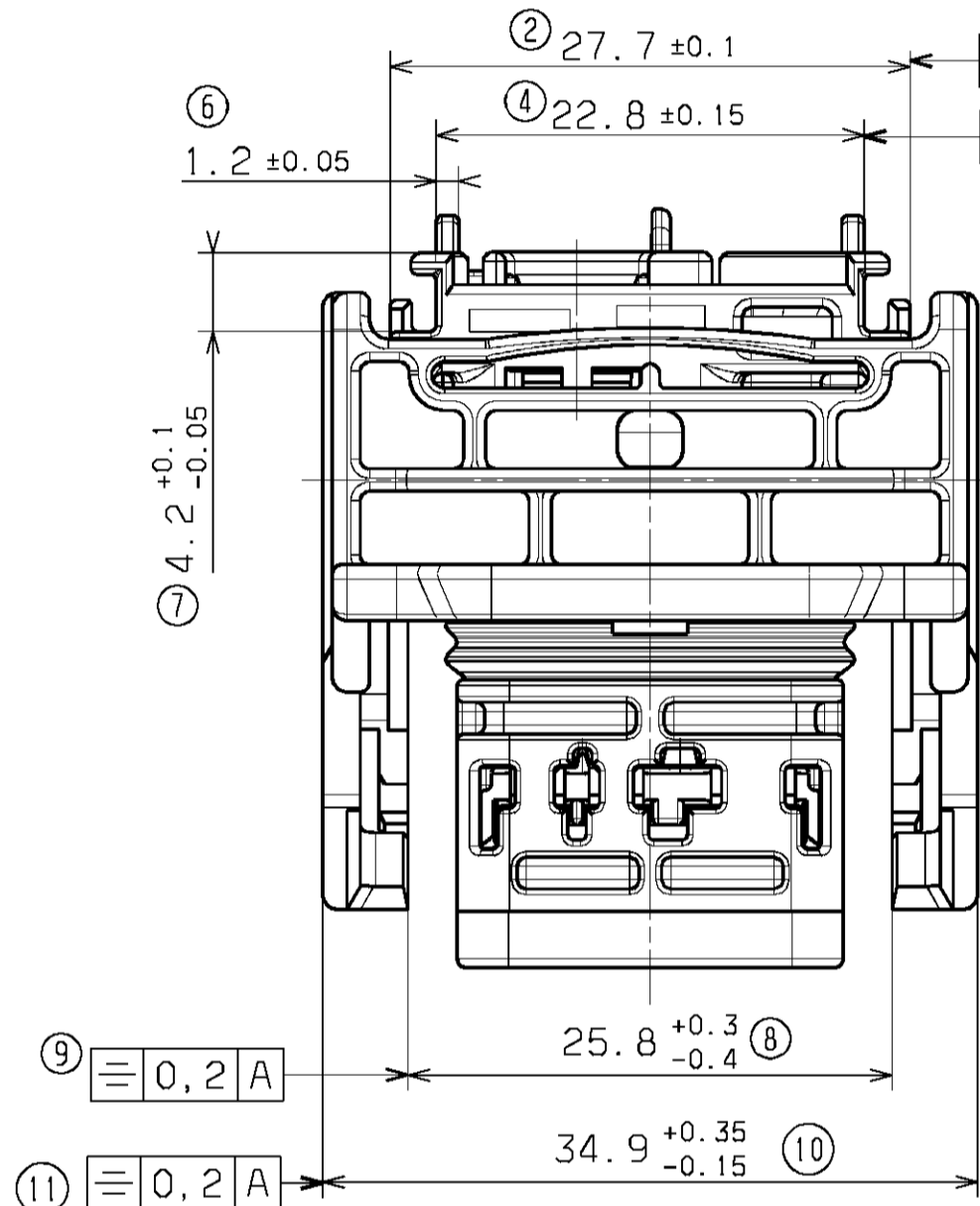

RIGHT WIRE OUTPUT

MATERIAL NUMBER	COLOR
0643183011	BLACK
0643183018	GREY
0643183019	BROWN

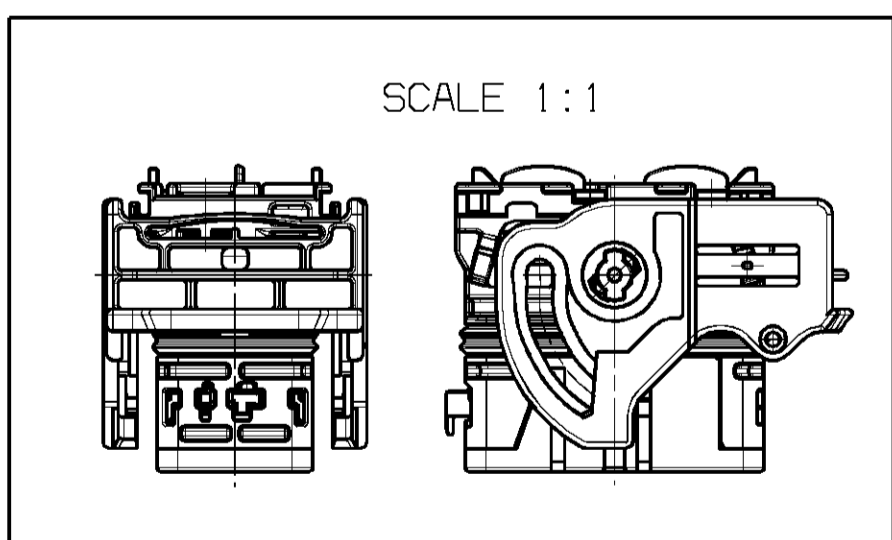
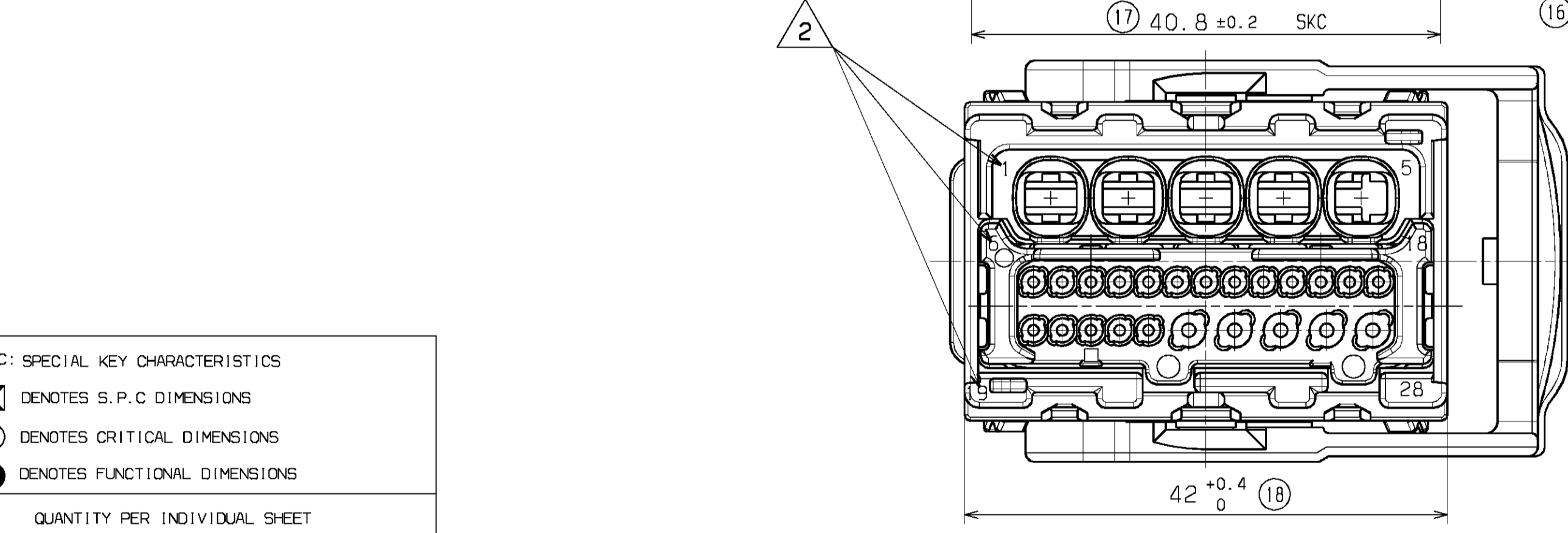

NOTES

- FOR ILLUSTRATION PURPOSE THE FEMALE HOUSING SHOWN IS THE RIGHT WIRE OUTPUT VERSION CODING 1
- APPLICATION SPECIFICATION: AS-64318-001
- THE CONNECTOR FITS WITH WIRE CAP (48WAY) MOLEX P/N 0643201301
- BLIND PLUG FOR 0.6, 1.5 AND 2.8 CAVITIES (MOLEX P/N 0643251010 0643251023 0643251091) MUST BE USED ON THIS PART
- DELIVERED PRODUCT WEIGHT: 35.2 g

SKC: SPECIAL KEY CHARACTERISTICS

⊠ DENOTES S.P.C DIMENSIONS

⊙ DENOTES CRITICAL DIMENSIONS

● DENOTES FUNCTIONAL DIMENSIONS

QUANTITY PER INDIVIDUAL SHEET

⊠ 0 ⊙ 0 ● 0 SKC: 2

7	MATT SEAL	SILICONE	GREEN ORANGE
6	BACK GRID 23 WAY	>PBT-GF20<	GREY
5	LOCKING LEVER SIZE 3	>PBT-GF30<	BLACK
4	SECONDARY LOCK	>PBT-GF20<	YELLOW
3	PERIPHERAL SEAL SIZE 3	SILICONE	RED
2	BACK PART	>PBT-GF20<	BROWN
1	FRONT PART	>PBT-GF20<	COLOR LINKED TO KEYING
REF.	DESIGNATION	MATERIAL	COLOR

MARKINGS

① Assembled part tracability day + year

② Terminal cavities identification

③ Lever position indicator:
"D" LETTER VISIBLE= part with "LEVER ON THE RIGHT"
"G" LETTER VISIBLE= part with "LEVER ON THE LEFT"

④ Supplier identification

⑤ Material identification

UPDATED DRAWING

EC NO: G2008-0367

DRWN: TBADAROUX 2008/05/16

CHK: OPLESSIS 2008/05/16

APPR: CBOUCHAN 2008/05/16

REV B

GENERAL TOLERANCES (UNLESS SPECIFIED)

	mm	INCH
4 PLACES	±	±
3 PLACES	±	±
2 PLACES	± 0.1	±
1 PLACE	± 0.1	±
ANGULAR ± 2°		

DRAFT WHERE APPLICABLE MUST REMAIN WITHIN DIMENSIONS

DIMENSION STYLE

MM ONLY

SCALE 2.5:1

DESIGN UNITS METRIC

FIRST ANGLE PROJECTION

DRAWN BY TBADAROUX DATE 2007/09/25

CHECKED BY OPLESSIS DATE 2007/09/25

APPROVED BY CBOUCHAN DATE 2007/09/25

MATERIAL NO. SEE CHART

DOCUMENT NO. SD-64318-001

SHEET NO. 1 OF 2

TITLE

CMC CONNECTOR 28 CKT POWER MAT SEAL VERSION

MOLEX INCORPORATED

THIS DRAWING CONTAINS INFORMATION THAT IS PROPRIETARY TO MOLEX INCORPORATED AND SHOULD NOT BE USED WITHOUT WRITTEN PERMISSION

CONNECTOR OVERALL DIMENSIONS:
SECONDARY LOCKING FULLY OPENED
FOR TERMINAL INSERTION

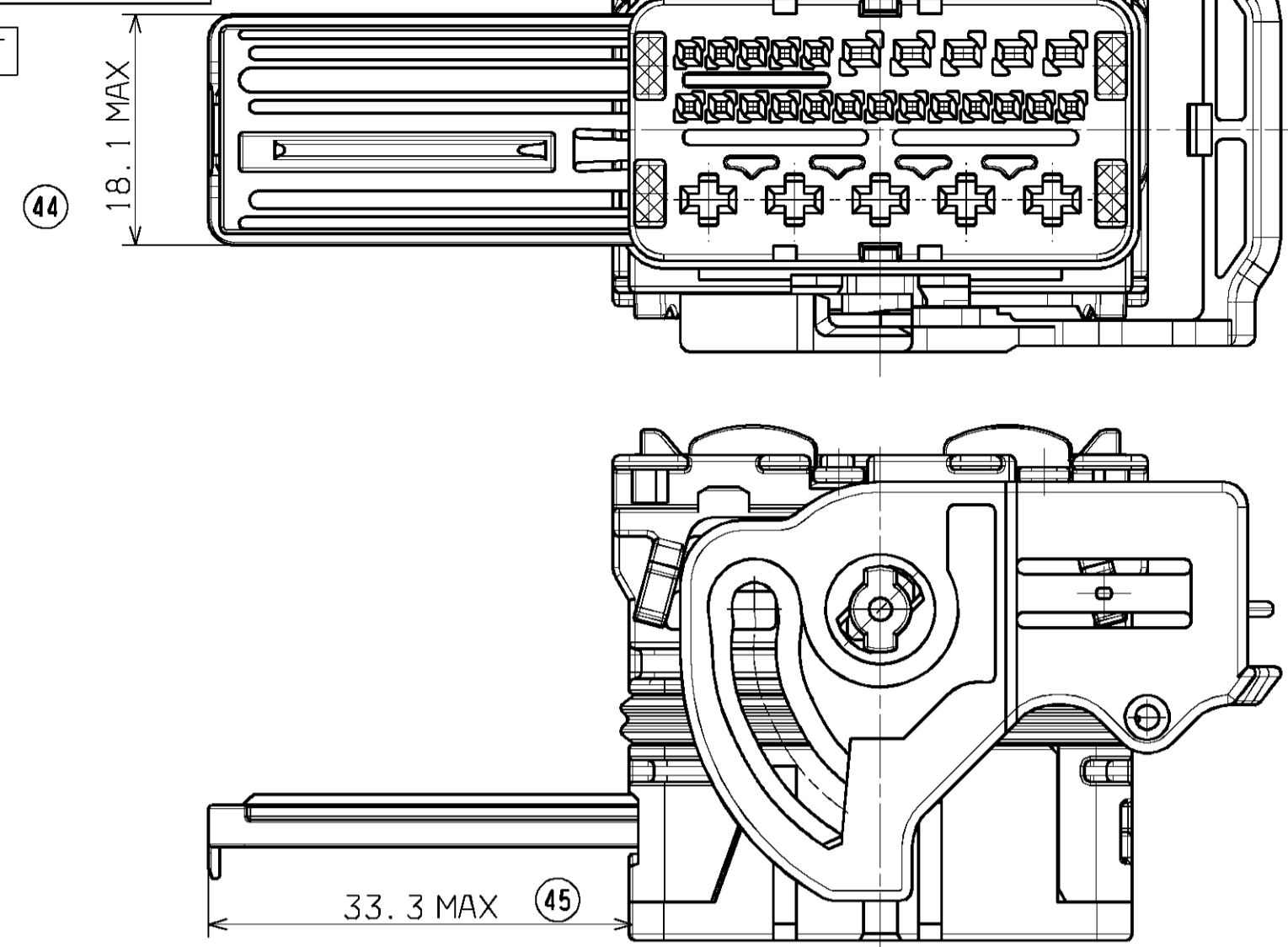

CONNECTOR OVERALL DIMENSIONS:
SECONDARY LOCKING IN
DELIVERY POSITION

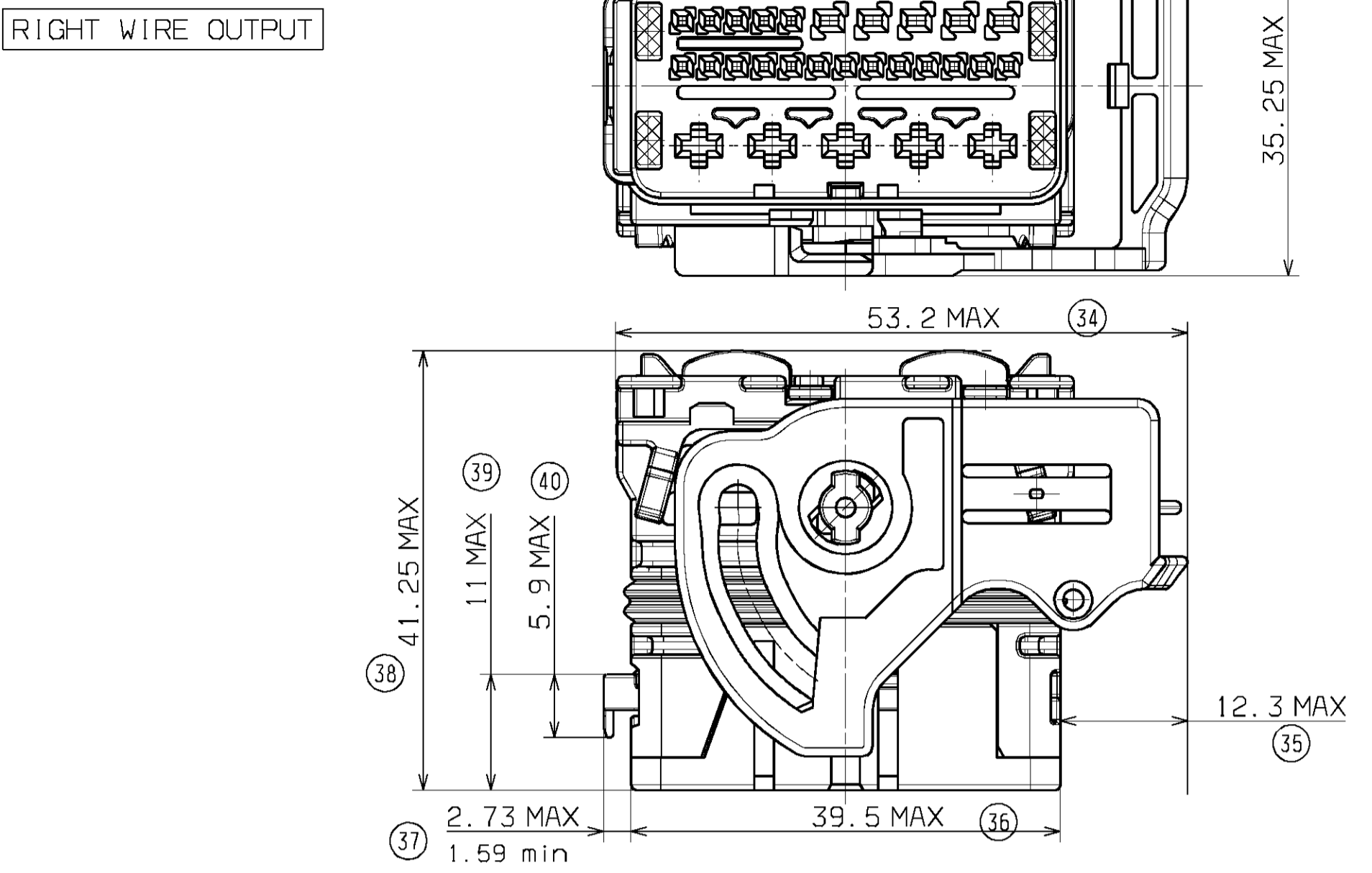

CODING POSITION

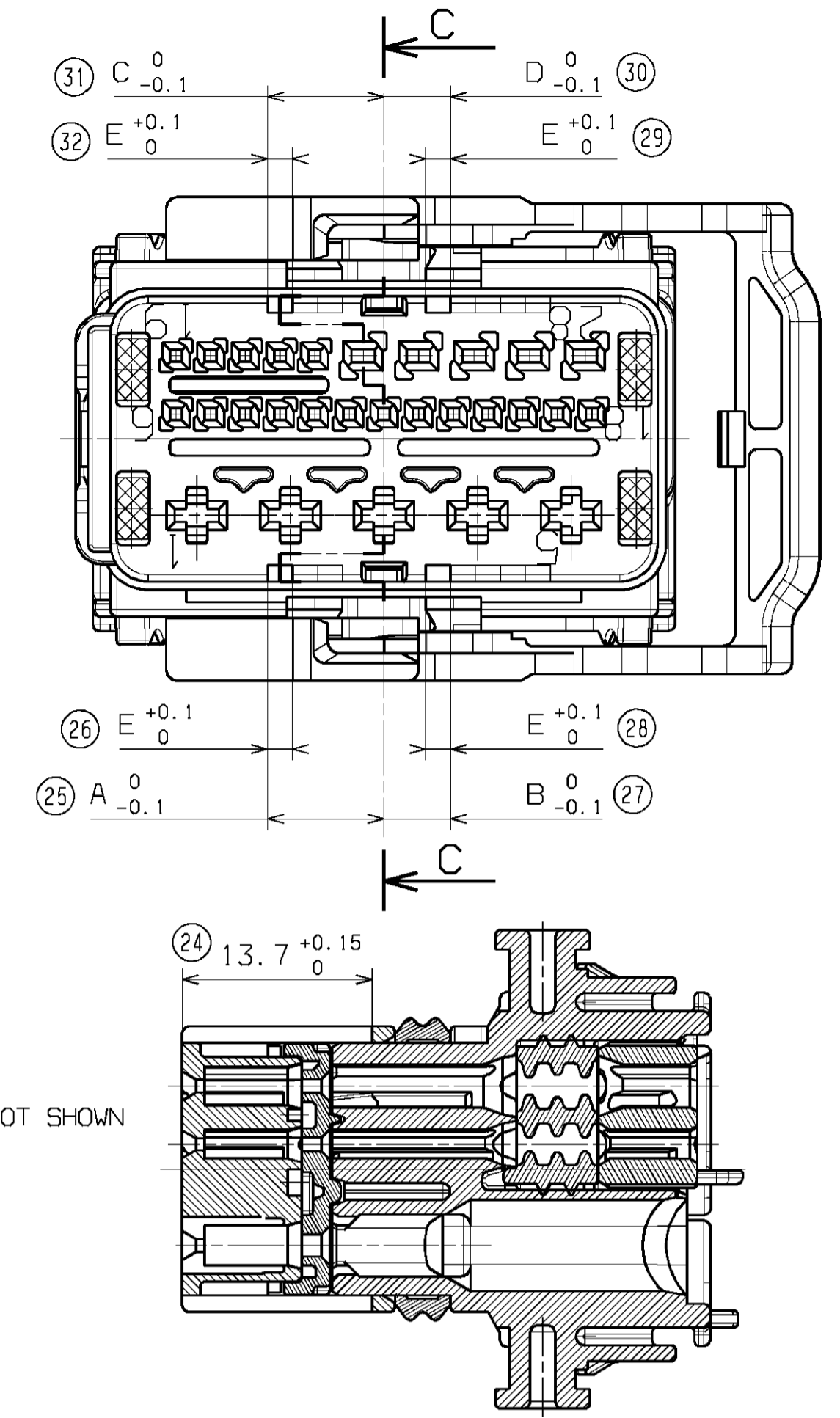

CONNECTOR OVERALL DIMENSIONS:
SECONDARY LOCKING FULLY OPENED
FOR TERMINAL INSERTION

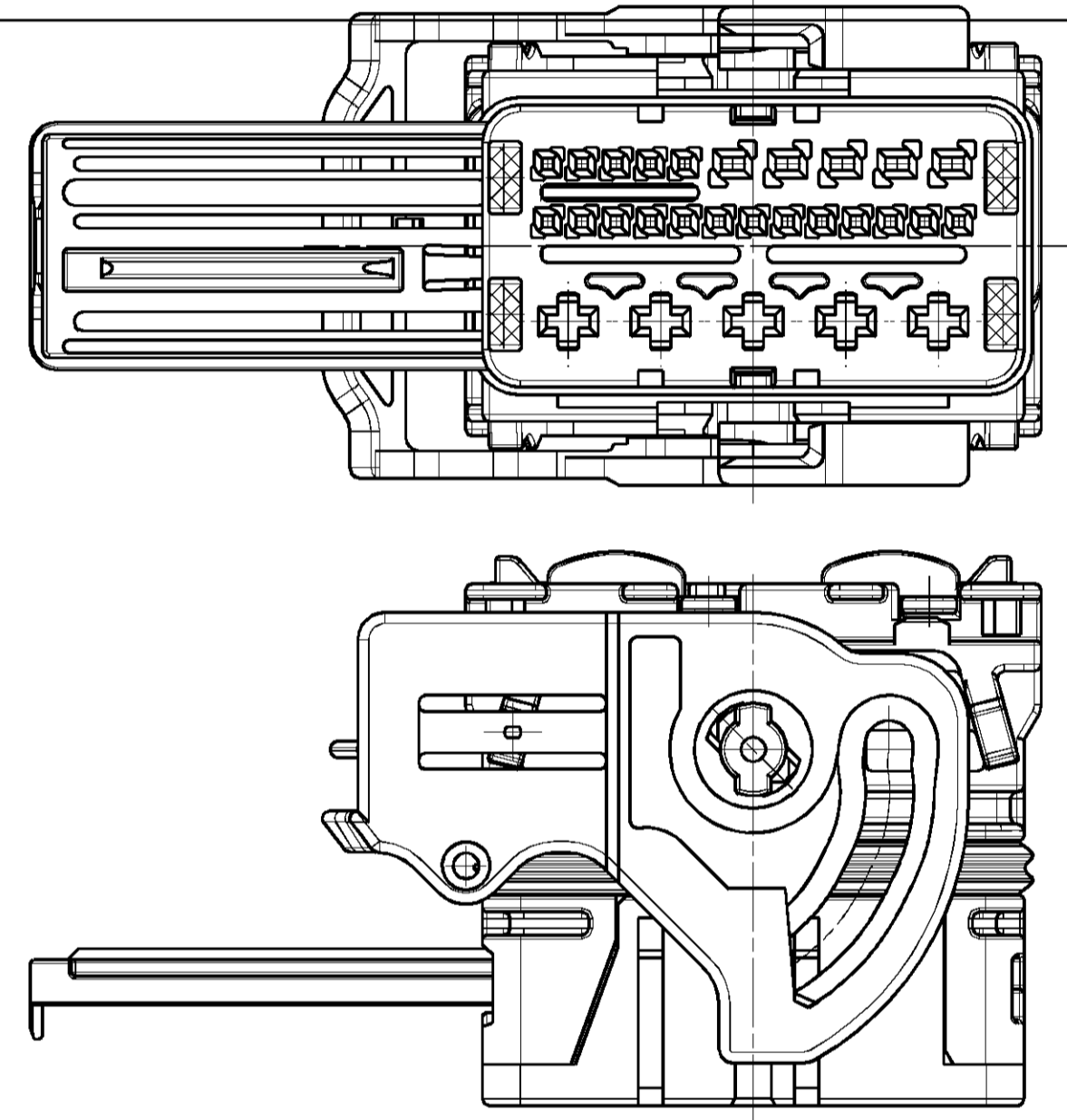

CONNECTOR OVERALL DIMENSIONS:
SECONDARY LOCKING IN
DELIVERY POSITION

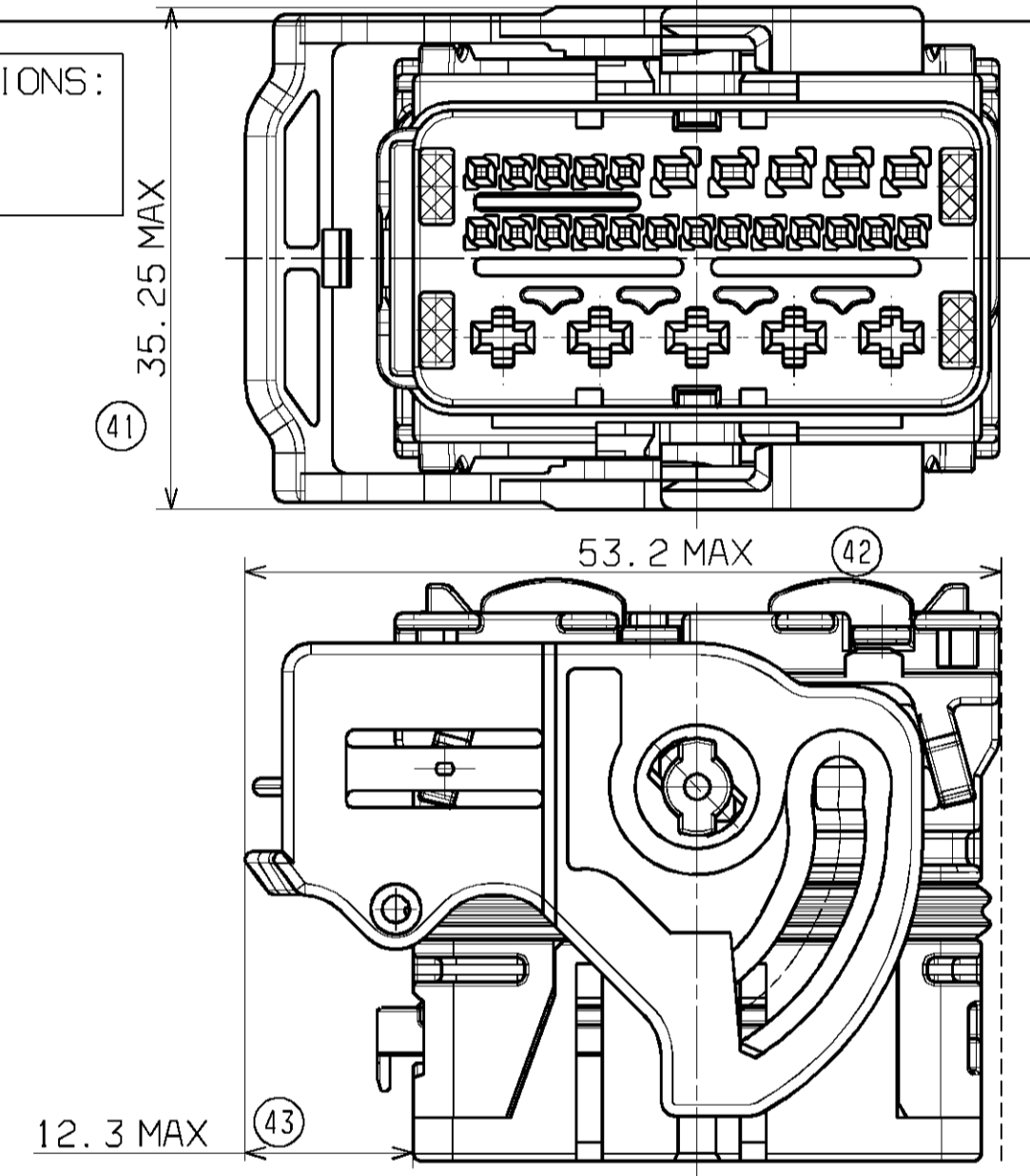

C-C
LOCKING LEVER NOT SHOWN

COLOR	KEYING	A	B	C	D	E
BLACK	1	8.4	4.8	8.4	4.8	1.8
GREY	2	8.4	6.6	6.6	6.6	1.8
BROWN	3	8.4	8.4	4.8	10.2	1.8

TERMINALS USED							
CAVITIES ID.	TERMINALS (Section mm ²)	REVEITEMENT PLATING	MOLEX P/N	WIRE SEAL	WIRE INSULATION DIAMETER		
6 to 23	CP 0.6 (0.35mm ² to 0.44mm ²)	Tin plated	0643221019	/	Ø1.25 min / Ø1.40 Max		
		Gold plated	0643221229				
	CP 0.6 (0.5mm ²)	Tin plated	0643221039			Ø1.40 min / Ø1.90 Max	
		Gold plated	0643221239			Ø1.40 min / Ø1.90 Max	
24 to 28	CP 0.6 (0.75mm ²)	Tin plated	0643221029	/	Ø1.40 min / Ø1.90 Max		
		Gold plated	0643221219				
	CP 1.5 (0.5mm ² to 1mm ²)	Tin plated	0643231029			Ø1.45 min / Ø2.15 Max	
		Gold plated	0643231319			Ø2.10 min / Ø2.80 Max	
1 to 5	CP 1.5 (>1mm ² to 2mm ²)	Tin plated	0643231039	/	Ø2.10 min / Ø2.80 Max		
		Gold plated	0643231219				
	CP 2.8 (>0.5mm ² to 1mm ²)	Tin plated	0643241049			0643251162	Ø1.40 min / Ø2.15 Max
		Gold plated	0643241149			Ø2.10 min / Ø2.80 Max	
	CP 2.8 (>1mm ² to 2mm ²)	Tin plated	0643241039			0643251175	Ø2.10 min / Ø2.80 Max
		Gold plated	0643241139			0643251188	Ø2.65 min / Ø3.45 Max
CP 2.8 (>2mm ² to 3mm ²)	Tin plated	0643241029	0643251196	Ø3.40 min / Ø4.00 Max			
	Gold plated	0643241129					
CP 2.8 (>3mm ² to 5mm ²)	Tin plated	0643241019					
	Gold plated	0643241119					

UPDATED DRAWING EC NO: G2008-0367 DRAWN: TBADAROUX 2008/05/16 CH'KO: OPLESSIS 2008/05/16 APPR: CBOUCHAN 2008/05/16	DIMENSION STYLE MM ONLY	SCALE 2:1	DESIGN UNITS METRIC	FIRST ANGLE PROJECTION		
		GENERAL TOLERANCES (UNLESS SPECIFIED)		TITLE CMC CONNECTOR 28 CKT POWER MAT SEAL VERSION		
		4 PLACES ± ± 3 PLACES ± ± 2 PLACES ± 0.1 ± 1 PLACE ± 0.1 ± ANGULAR ± 2°	DRAWN BY TBADAROUX	DATE 2007/09/25	MATERIAL NO. SEE CHART	
		DRAFT WHERE APPLICABLE MUST REMAIN WITHIN DIMENSIONS		CHECKED BY OPLESSIS	DATE 2007/09/25	DOCUMENT NO. SD-64318-001
SIZE A1		THIS DRAWING CONTAINS INFORMATION THAT IS PROPRIETARY TO MOLEX INCORPORATED AND SHOULD NOT BE USED WITHOUT WRITTEN PERMISSION				

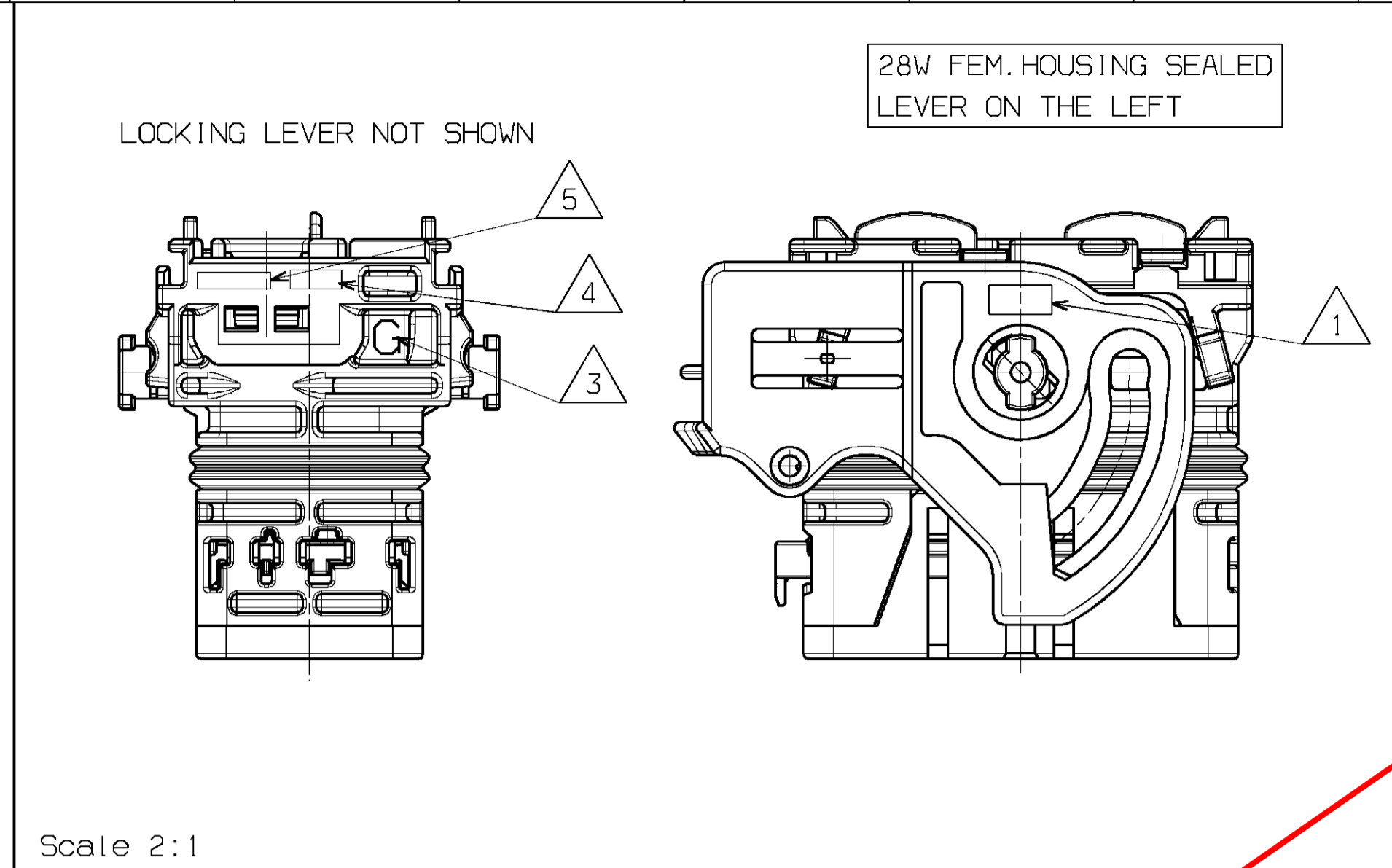
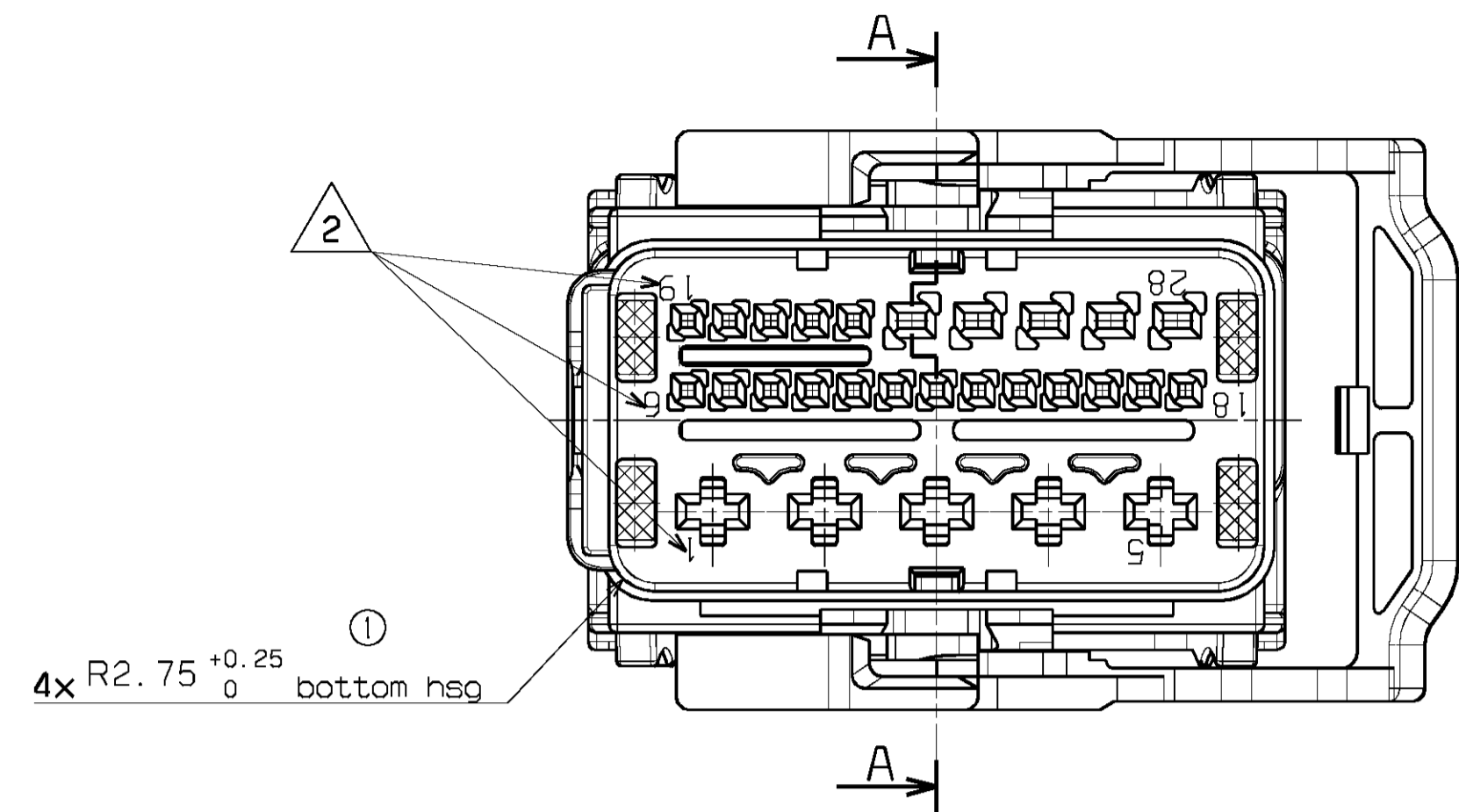

LEVER ON THE LEFT

MATERIAL NUMBER	COLOR
0643181011	BLACK
0643181018	GREY
0643181019	BROWN
	GREEN

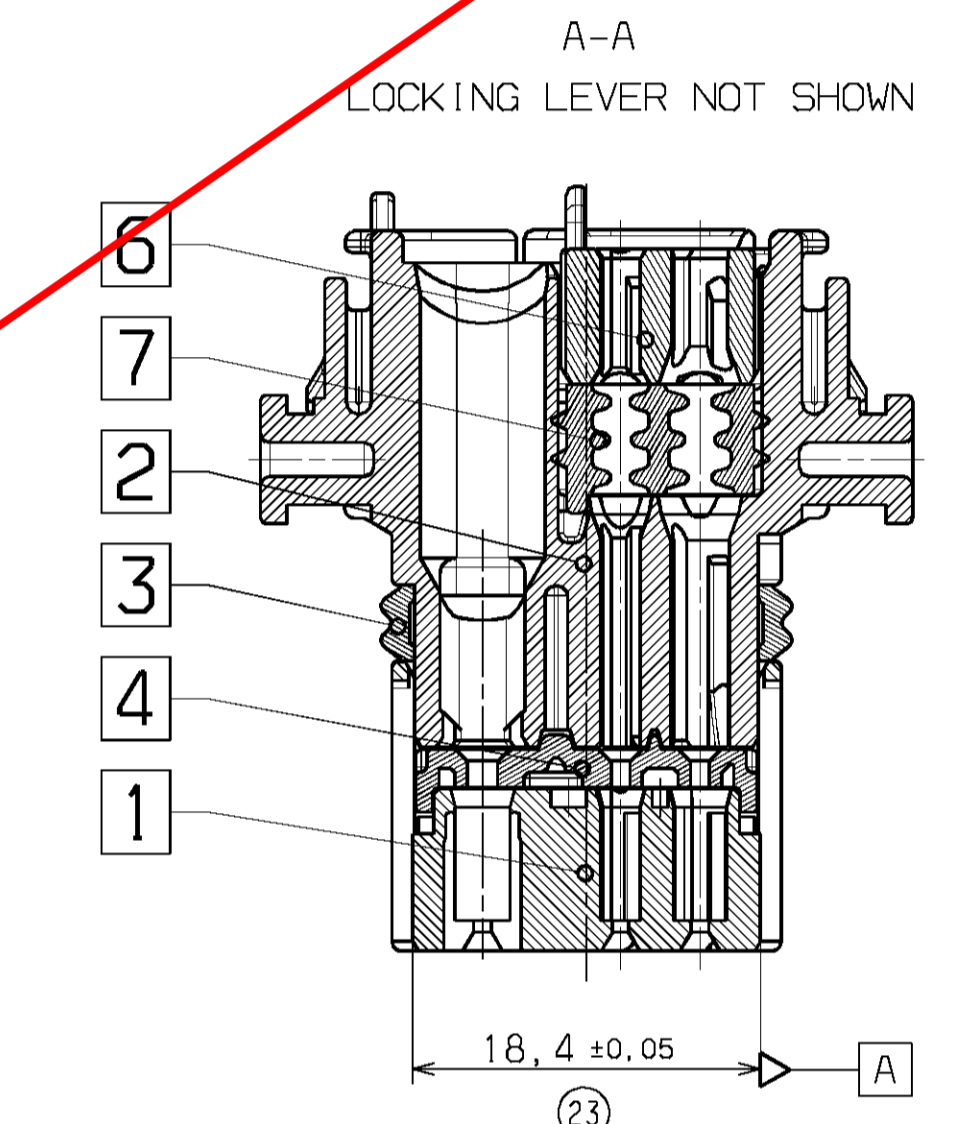
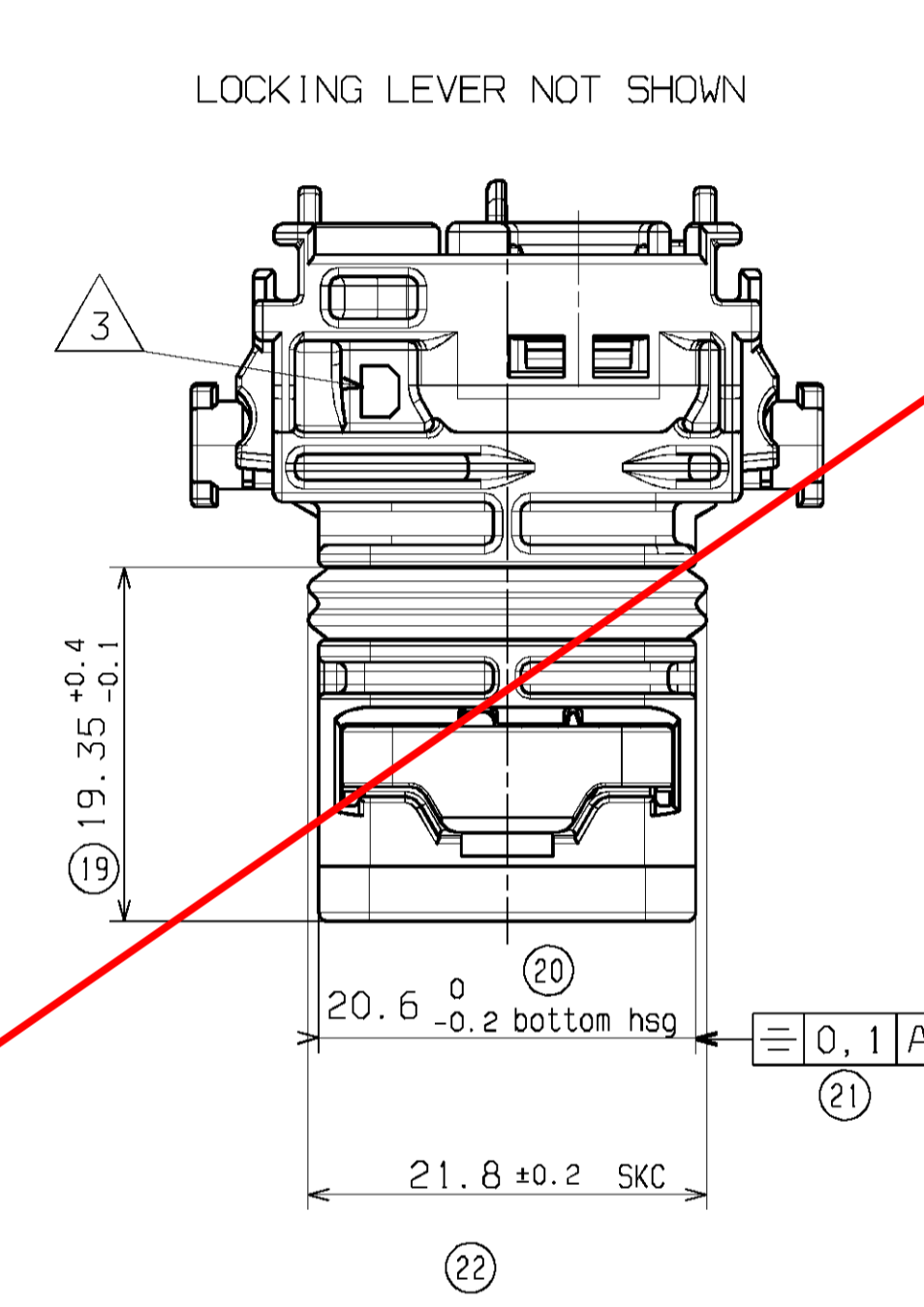
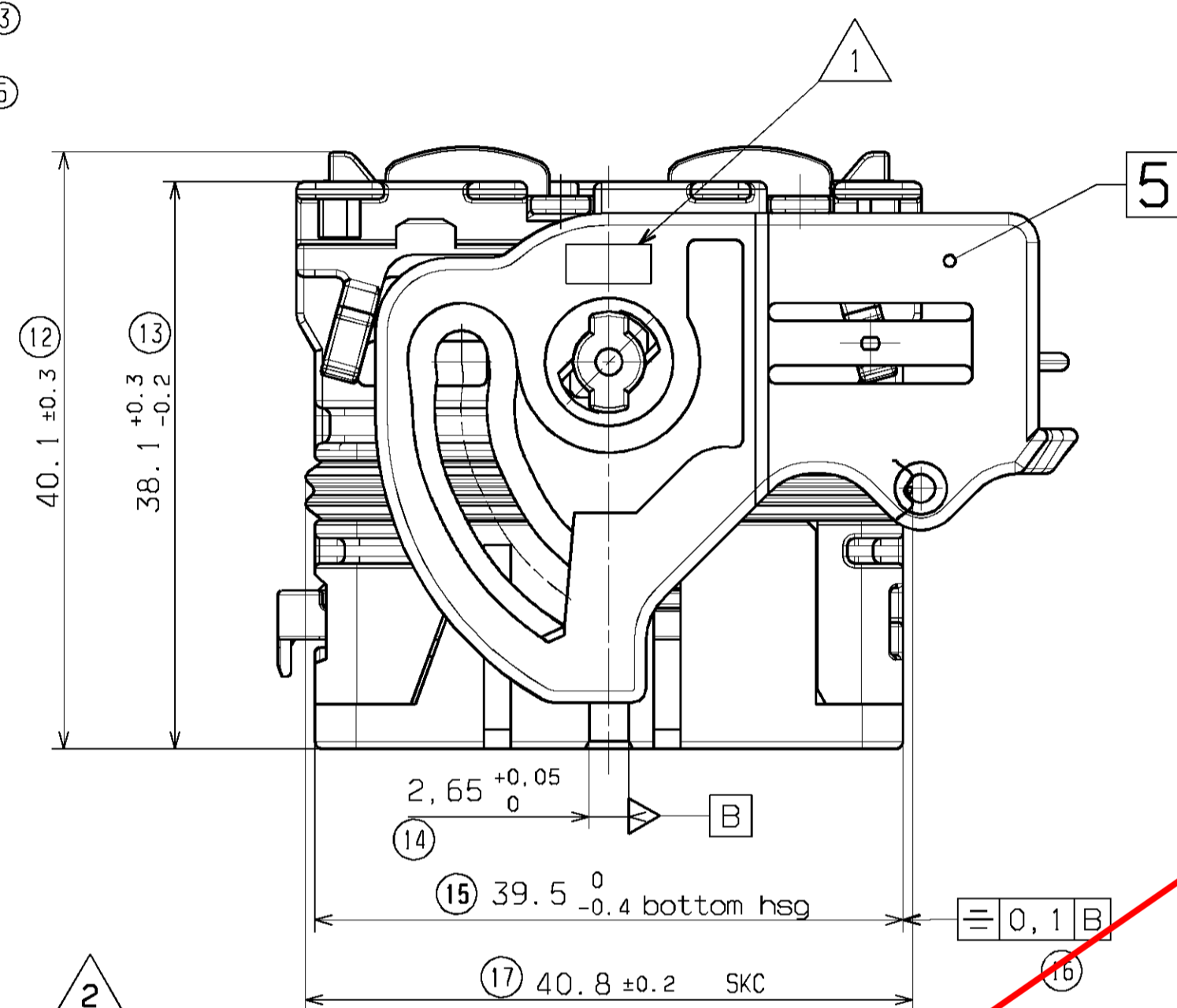
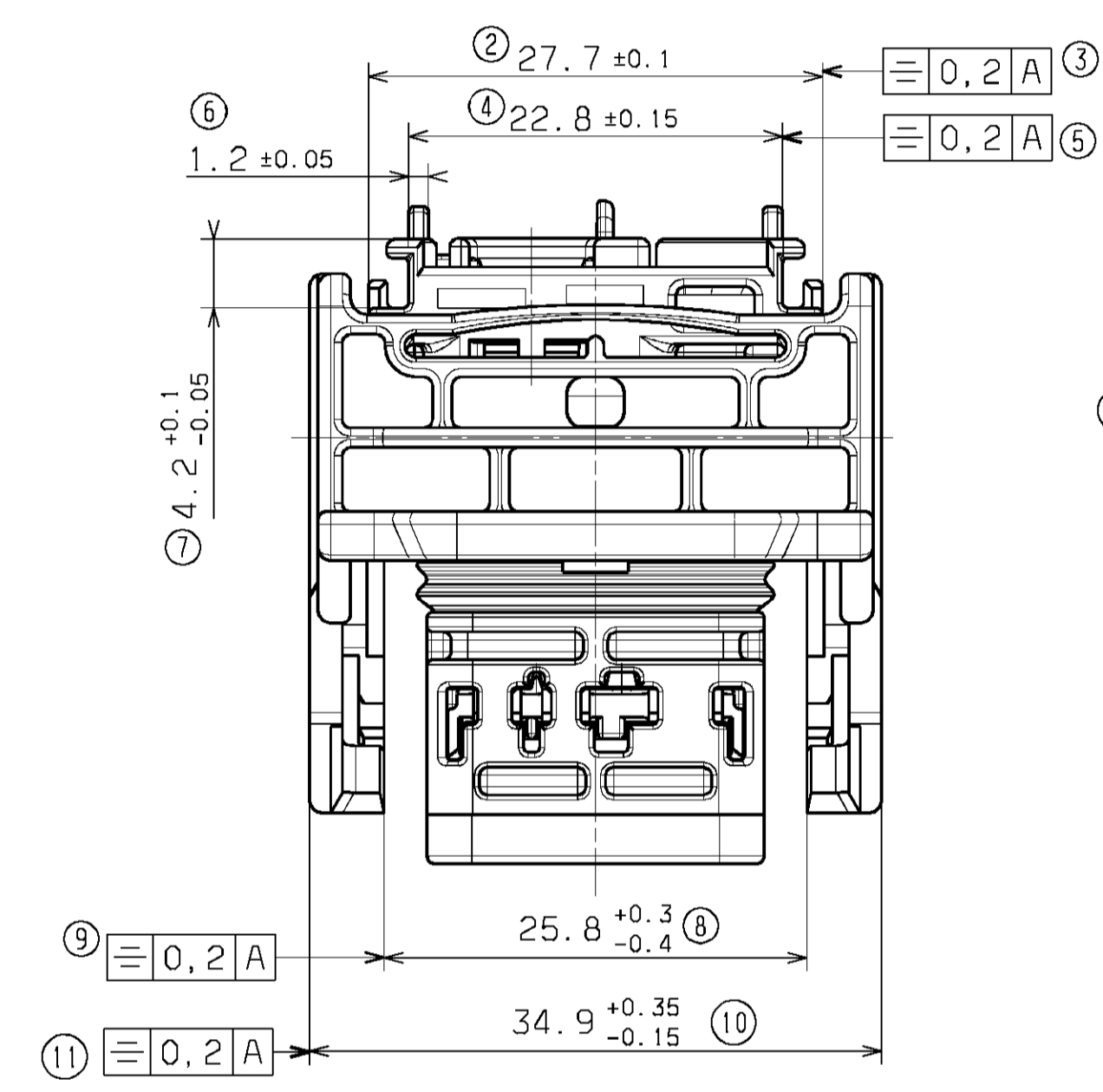

LEVER ON THE RIGHT

MATERIAL NUMBER	COLOR
0643183011	BLACK
0643183018	GREY
0643183019	BROWN
	GREEN

NOTES

- 1-FOR ILLUSTRATION PURPOSE THE FEMALE HOUSING SHOWN IS THE RIGHT WIRE OUTPUT VERSION CODING 1
- 2-INTERFACE DEFINITION, OVERALL DIMENSION AND LOCATION ON HEADER AS PER RSD-98994-002
- 3-CAVITIES TERMINALS DESIGN AS PER
- 7-BLIND PLUG FOR 0.6, 1.5 AND 2.8 CAVITIES (MOLEX P/N 0643251010 0643251023 0643251091) MUST BE USED ON THIS PART
- 8-DELIVERED PRODUCT WEIGHT: 35,2 g

VOID AND SUPERSEDED BY SD-64318-001 rev B

SKC: SPECIAL KEY CHARACTERISTICS

- ☒ DENOTES S.P.C DIMENSIONS
- ⊙ DENOTES CRITICAL DIMENSIONS
- DENOTES FUNCTIONAL DIMENSIONS

QUANTITY PER INDIVIDUAL SHEET

☒ 0 ⊙ 0 ● 0 SKC: 2

0989940094	7	MATT SEAL	SILICONE	GREEN ORANGE
0989940093				
0989940058	6	BACK GRID 23 WAY	>PBT-GF20<	GREY
0989930341	5	LOCKING LEVER SIZE 3	>PBT-GF30<	BLACK
0989940034	4	SECONDARY LOCK	>PBT-GF20<	YELLOW
0986560002	3	PERIPHERAL SEAL SIZE 3	SILICONE	RED
0989940019	2	BACK PART	>PBT-GF20<	BROWN
0989940021				
0989940028				
0989940029	1	FRONT PART	>PBT-GF20<	COLOR ASSOCIATED TO KEYING
MATERIAL NUMBER	MARK	DESIGNATION	MATERIAL	COLOR

MARKINGS

- 1 Assembled part tracability day + year
- 2 Terminal cavities identification
- 3 Lever position indicator:
"D" LETTER VISIBLE= part with "LEVER ON THE RIGHT"
"G" LETTER VISIBLE= part with "LEVER ON THE LEFT"
- 4 Supplier identification
- 5 Material identification

GENERAL TOLERANCES (UNLESS SPECIFIED)		DIMENSION STYLE		SCALE	DESIGN UNITS	FIRST ANGLE PROJECTION
mm	INCH	MM ONLY		2.5:1	METRIC	
4 PLACES ±	±	DRAWN BY TBADAROUX		DATE 2007/09/25	TITLE CMC CONNECTOR 28 CKT POWER MATT SEAL VERSION	
3 PLACES ±	±	CHECKED BY OPLESSIS		DATE 2007/09/25	MOLEX INCORPORATED	
2 PLACES ± 0.1	±	APPROVED BY CBOUCHAN		DATE 2007/09/25	MATERIAL NO. SEE CHART	
1 PLACE ± 0.1	±	ANGULAR ± 2°		DOCUMENT NO. SD-98994-001		SHEET NO. 1 OF 2
DRAFT WHERE APPLICABLE MUST REMAIN WITHIN DIMENSIONS				THIS DRAWING CONTAINS INFORMATION THAT IS PROPRIETARY TO MOLEX INCORPORATED AND SHOULD NOT BE USED WITHOUT WRITTEN PERMISSION		

CONNECTOR OVERALL DIMENSIONS:
SECONDARY LOCKING FULLY OPENED
FOR TERMINAL INSERTION

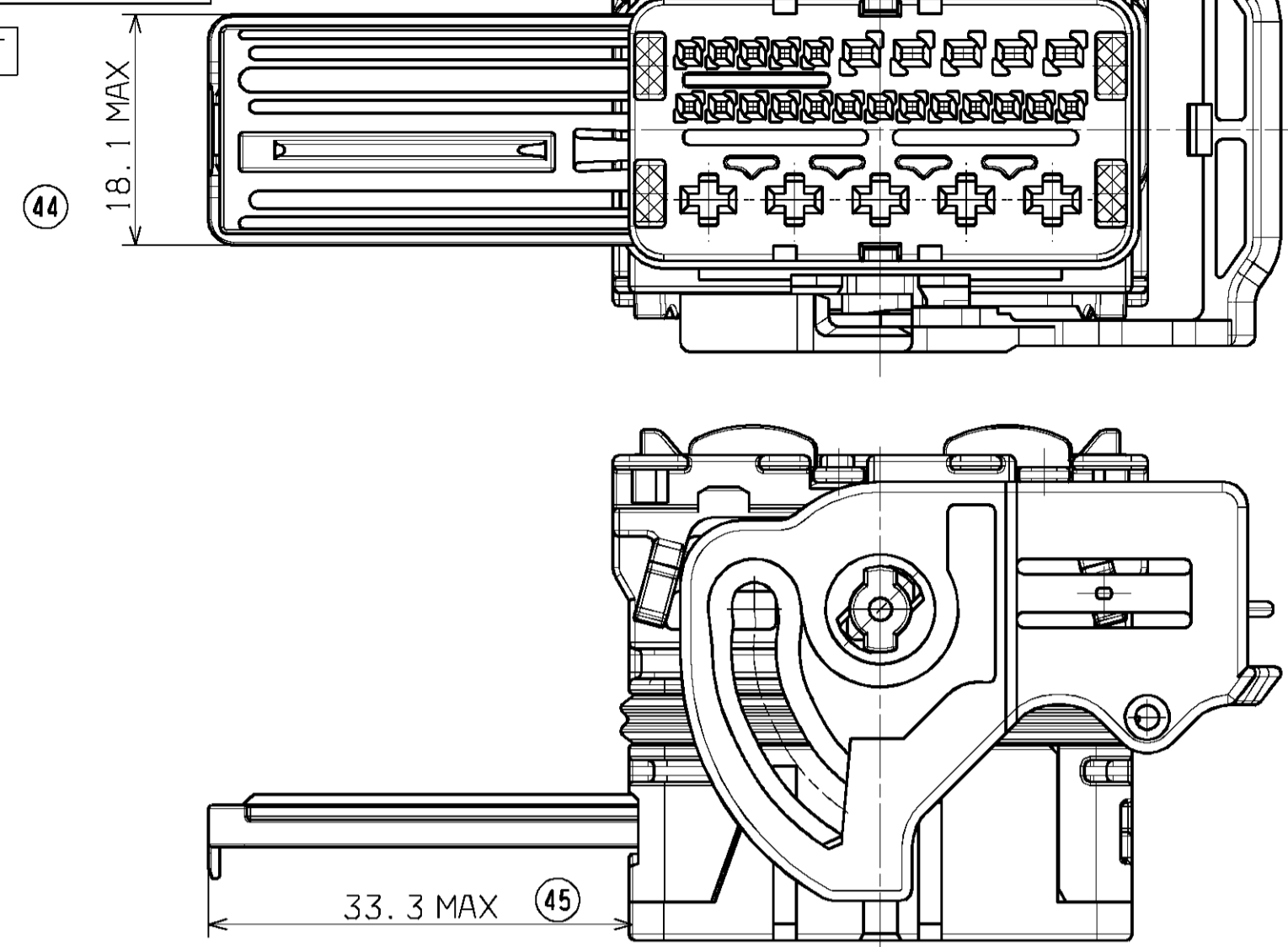

CONNECTOR OVERALL DIMENSIONS:
SECONDARY LOCKING IN
DELIVERY POSITION

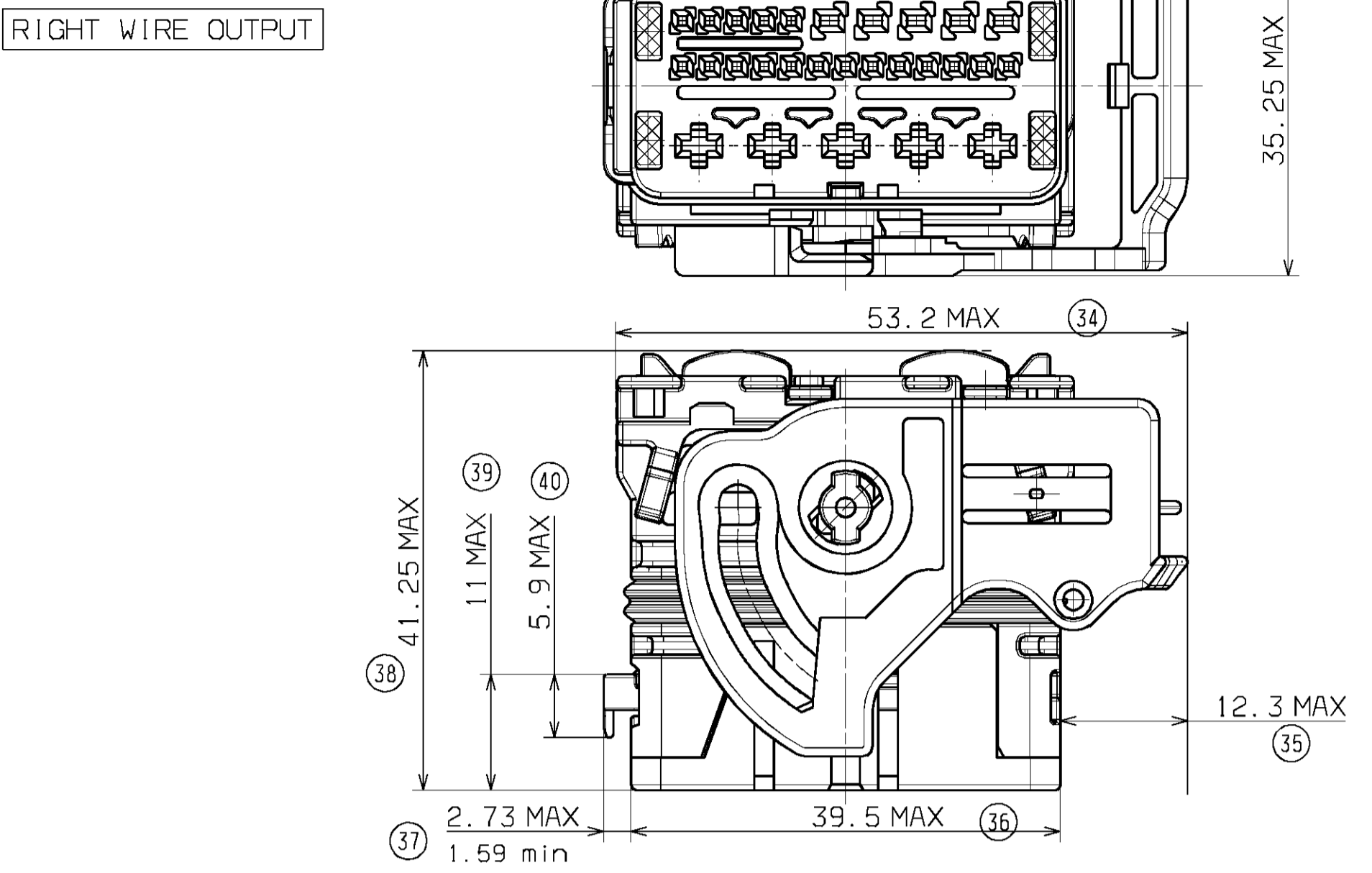

CODING POSITION

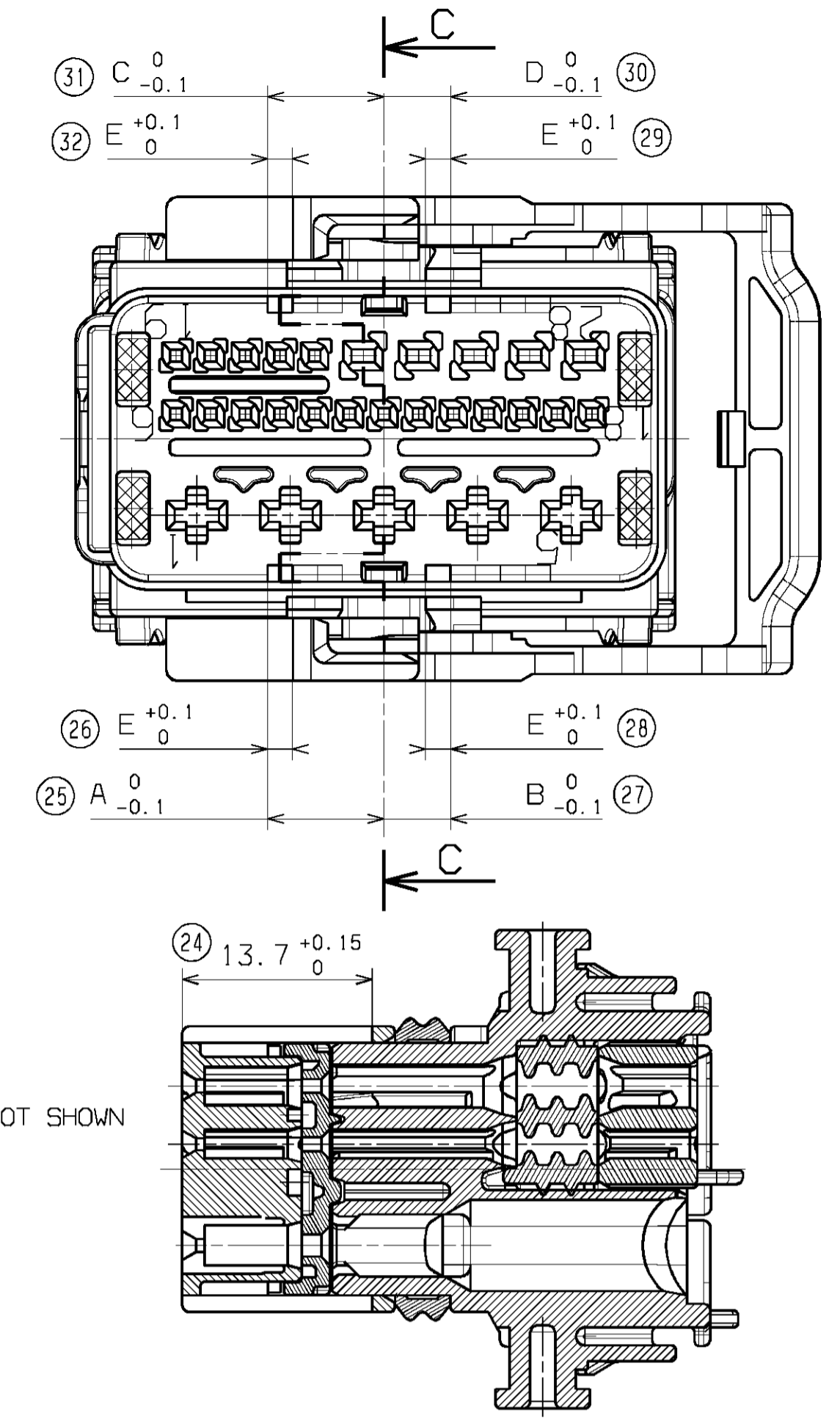

CONNECTOR OVERALL DIMENSIONS:
SECONDARY LOCKING FULLY OPENED
FOR TERMINAL INSERTION

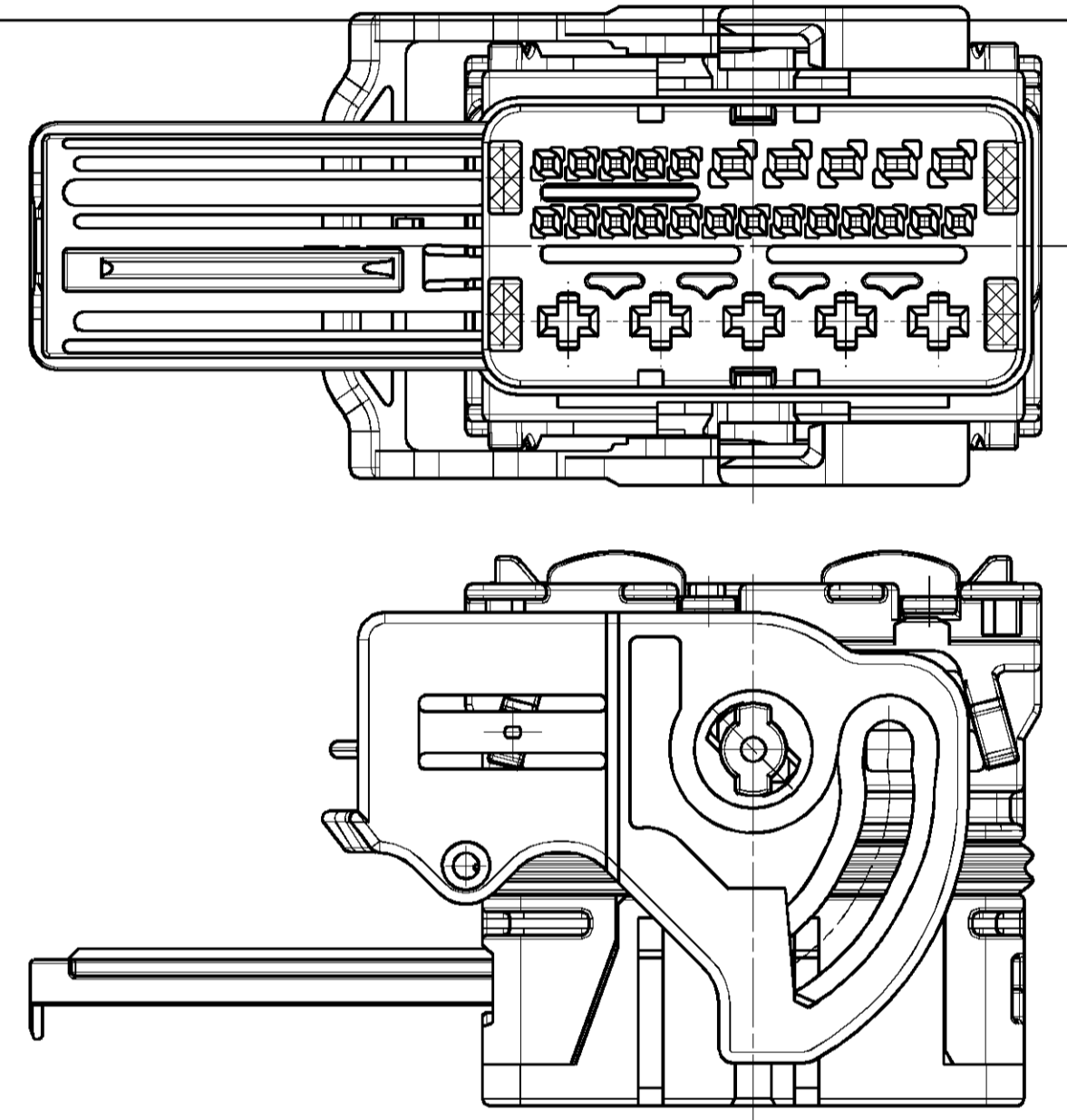

CONNECTOR OVERALL DIMENSIONS:
SECONDARY LOCKING IN
DELIVERY POSITION

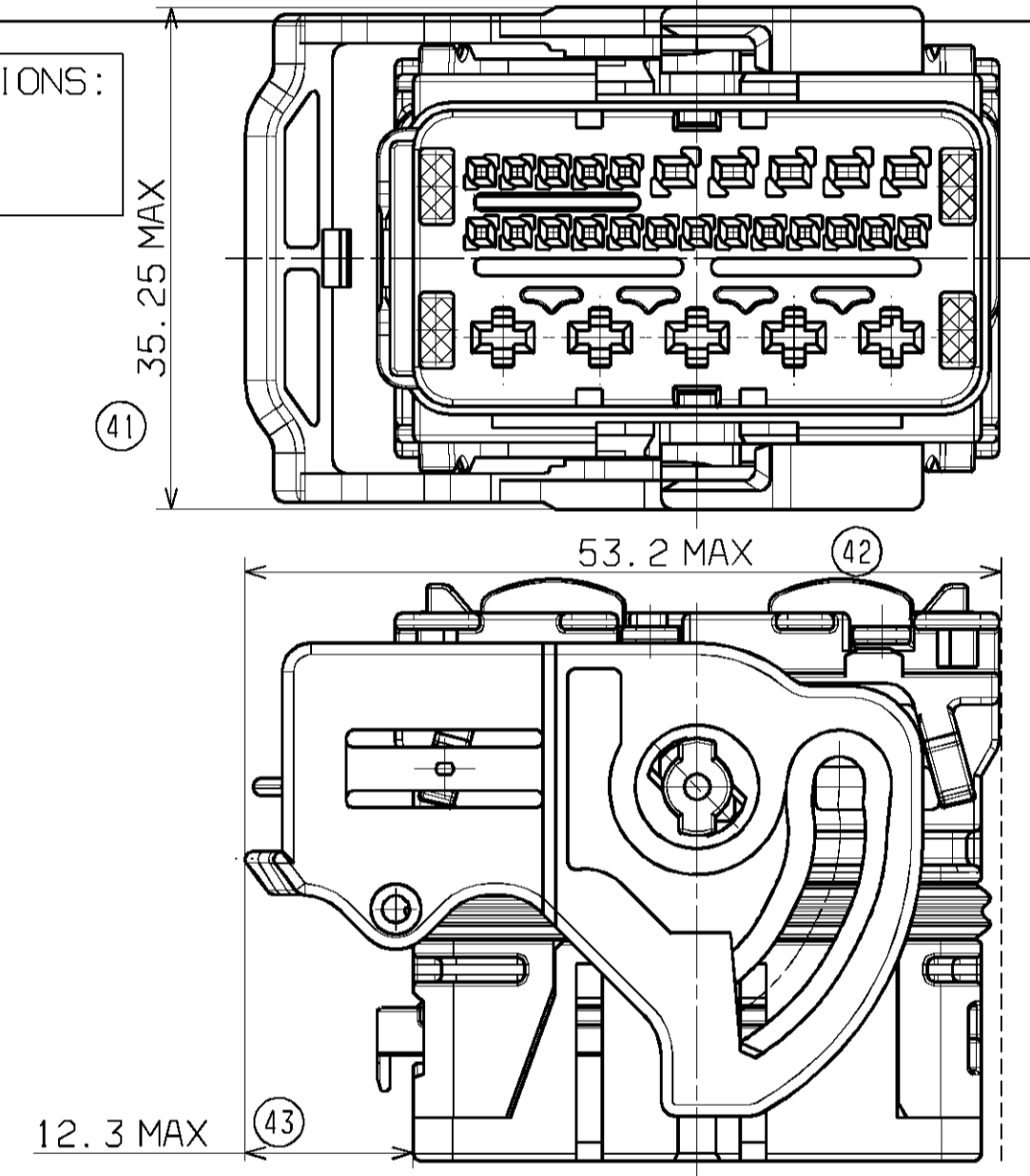

C-C
LOCKING LEVER NOT SHOWN

COLOR	KEYING	A	B	C	D	E
BLACK	1	8.4	4.8	8.4	4.8	1.8
GREY	2	8.4	6.6	6.6	6.6	1.8
BROWN	3	8.4	8.4	4.8	10.2	1.8
GREEN	4	4.8	10.2	8.4	12.0	1.8

TERMINALS USED							
CAVITIES ID.	TERMINALS (Section mm ²)	REVEITEMENT PLATING	MOLEX P/N	WIRE SEAL	WIRE INSULATION DIAMETER		
6 to 23	CP 0.6 (0.35mm ² to 0.44mm ²)	Tin plated	0643221019	/	Ø1.25 min / Ø1.40 Max		
		Gold plated	0643221229				
	CP 0.6 (0.5mm ²)	Tin plated	0643221039			Ø1.40 min / Ø1.90 Max	
		Gold plated	0643221239			Ø1.40 min / Ø1.90 Max	
24 to 28	CP 0.6 (0.75mm ²)	Tin plated	0643221029	/	Ø1.40 min / Ø1.90 Max		
		Gold plated	0643221219				
	CP 1.5 (0.5mm ² to 1mm ²)	Tin plated	0643231029			Ø1.45 min / Ø2.15 Max	
		Gold plated	0643231319			Ø2.10 min / Ø2.80 Max	
1 to 5	CP 1.5 (>1mm ² to 2mm ²)	Tin plated	0643231039	/	Ø2.10 min / Ø2.80 Max		
		Gold plated	0643231219				
	CP 2.8 (>0.5mm ² to 1mm ²)	Tin plated	0643241049			0643251162	Ø1.40 min / Ø2.15 Max
		Gold plated	0643241149			Ø2.10 min / Ø2.80 Max	
	CP 2.8 (>2mm ² to 3mm ²)	Tin plated	0643241039			0643251175	Ø2.10 min / Ø2.80 Max
Gold plated		0643241139	0643251188	Ø2.65 min / Ø3.45 Max			
Tin plated		0643241029	0643251196	Ø3.40 min / Ø4.00 Max			
CP 2.8 (>3mm ² to 5mm ²)	Gold plated	0643241119					

UPDATED DRAWING EC NO: G2008-0367 DRAWN: TBADAROUX 2008/04/21 CH'KO: OPLESSIS 2008/04/21 APPR: CBOUCHAN 2008/04/21	DIMENSION STYLE MM ONLY	SCALE 2:1	DESIGN UNITS METRIC	FIRST ANGLE PROJECTION	
		GENERAL TOLERANCES (UNLESS SPECIFIED) mm INCH		TITLE CMC CONNECTOR 28 CKT POWER MATT SEAL VERSION	
		4 PLACES ± ± 3 PLACES ± ± 2 PLACES ± 0.1 ± 1 PLACE ± 0.1 ± ANGULAR ± 2°		DRAWN BY DATE TBADAROUX 2007/09/25	
		DRAFT WHERE APPLICABLE MUST REMAIN WITHIN DIMENSIONS		CHECKED BY DATE OPLESSIS 2007/09/25	
		APPROVED BY DATE CBOUCHAN 2007/09/25		MATERIAL NO. SEE CHART	
		DOCUMENT NO. SD-98994-001		SHEET NO. 2 OF 2	
		THIS DRAWING CONTAINS INFORMATION THAT IS PROPRIETARY TO MOLEX INCORPORATED AND SHOULD NOT BE USED WITHOUT WRITTEN PERMISSION			