

150mA High Voltage Low Dropout Linear Regulator

Description

The FP6160 is a high voltage, low dropout, positive linear regulator with very low quiescent current. The precision of feedback reference voltage is within $\pm 1\%$ and output current is up to 150mA.

The FP6160 is designed and optimized to work with low-value, low cost ceramic capacitors. The FP6160 consumes less than 1 μ A during shutdown mode, allowing for flexibility in power management. Besides its current limit protection and on chip thermal shutdown features provide protection against any combination of overload or ambient temperature that could exceed junction temperature.

The FP6160 is housed in low-profile, space-saving SOT-23-5 and TSOT-23-5 packages.

Features

- Operating Voltage from 5V to 18V
- High Power Supply Ripple Rejection at 65dB
- Guaranteed 150mA Output Current
- Very Low Quiescent Current at 70 μ A
- 1% Initial Accuracy
- Needs Only 1 μ F Capacitor for Stability
- Thermal Shutdown Protection
- Current Limit Protection
- Active Low Shutdown Control
- Low-ESR Ceramic Capacitor for Output Stability
- RoHS Compliant

Applications

- DSC
- Wireless Device
- LCD Module
- Battery Power System
- Card Reader
- PDA

Pin Assignments

S5 Package (SOT-23-5)

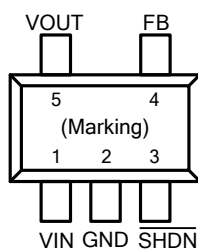

S8 Package (TSOT-23-5)

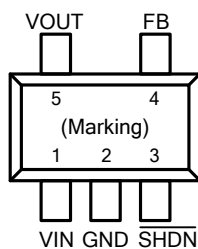

Ordering Information

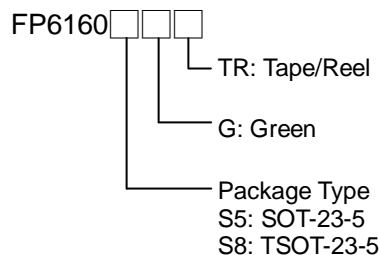

SOT-23-5 Marking

Part Number	Product Code
FP6160S5GTR	P6=

TSOT-23-5 Marking

Part Number	Product Code
FP6160S8GTR	FB7

Figure 1. Pin Assignment of FP6160

Typical Application Circuit

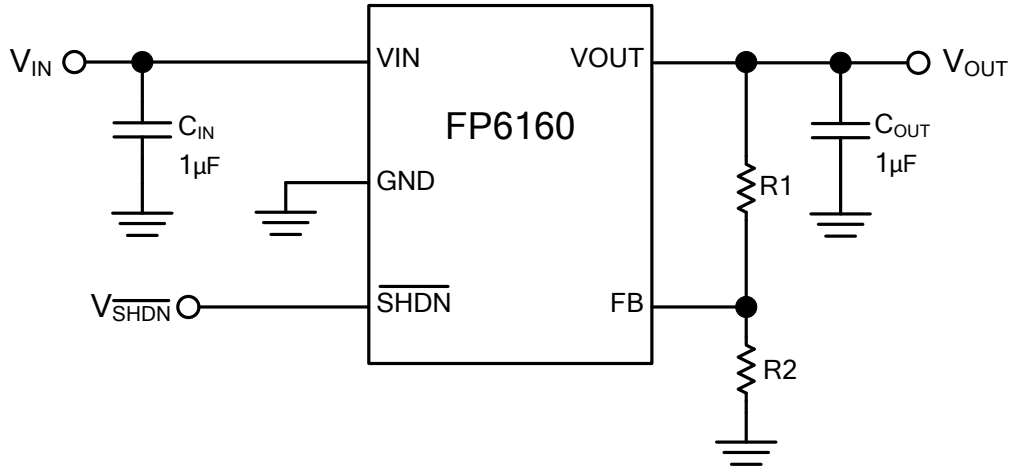

Figure 2. Typical Application Circuit of FP6160

Functional Pin Description

Pin Name	Pin No.	Pin Function
VIN	1	Power is supplied to this device from this pin which requires an input filter capacitor. In general, the input capacitor in the range of 1µF to 10µF is sufficient.
GND	2	Common ground pin.
$\overline{\text{SHDN}}$	3	Pull this pin high to enable FP6160, and pull this pin low to shutdown the device.
FB	4	Output voltage feedback.
VOUT	5	The output supplies power to loads. The output capacitor is required to prevent output voltage from oscillation. The large output capacitor could reduce output noise, improve stability and PSRR.

Block Diagram

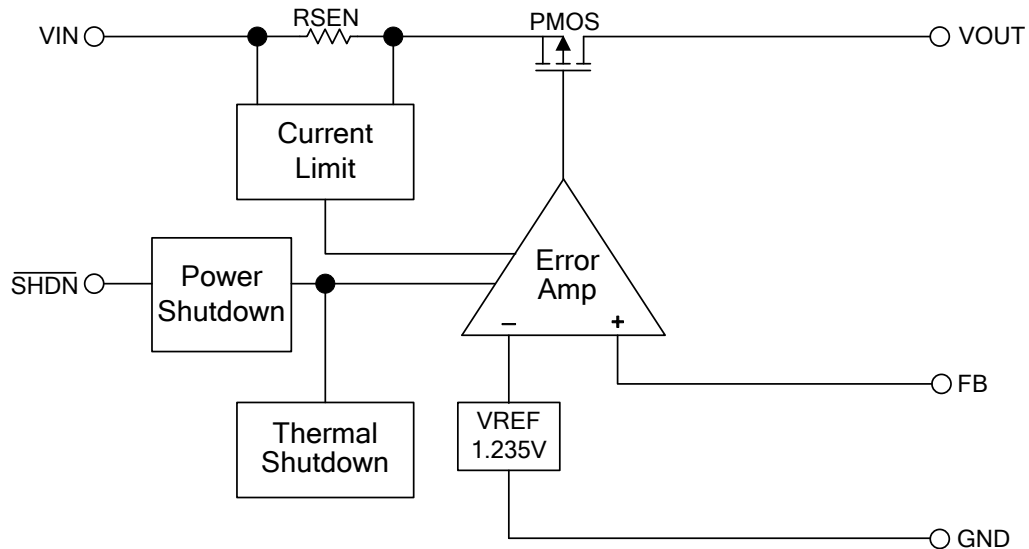

Figure 3. Block Diagram of FP6160

Absolute Maximum Ratings

- VIN, VOUT, SHDN ----- +20V
- FB ----- +6V
- Power Dissipation @25°C, (P_D) ----- +0.4W
 - SOT-23-5 ----- +0.4W
 - TSOT-23-5 ----- +0.4W
- Package Thermal Resistance, (θ_{JA})
 - SOT-23-5 ----- +250°C/W
 - TSOT-23-5 ----- +250°C/W
- Package Thermal Resistance, (θ_{JC})
 - SOT-23-5 ----- +130°C/W
 - TSOT-23-5 ----- +90°C/W
- Maximum Junction Temperature (T_J) ----- +150°C
- Storage Temperature Range (T_{STG}) ----- -65°C to +150°C
- Lead Temperature (Soldering, 10 sec.) (T_{LEAD}) ----- +260°C

Note 1 : Stresses beyond those listed under "Absolute Maximum Ratings" may cause permanent damage to the device.

Recommended Operating Conditions

- Input Voltage (V_{IN}) ----- +5V to +18V
- Operating Temperature Range (T_{OPR}) ----- -40°C to +85°C

Electrical Characteristics

($V_{IN}=15V$, \overline{SHDN} pin connected to V_{IN} , $C_{IN}=1\mu F$, $C_{OUT}=1\mu F$, $T_A=25^\circ C$, unless otherwise specified)

Parameter	Symbol	Conditions	Min	Typ	Max	Unit
Output Voltage Tolerance (V_{OUT})	ΔV_{OUT}		-1		1	%
Current Limit	I_{LIMIT}	$R_{Load}=1\Omega$		360	500	mA
Quiescent Current	I_Q	$I_O=0mA$		55	90	μA
Standby Current	I_{STBY}	$\overline{SHDN} = GND$			1	μA
Feedback Reference	V_{FB}		1.222	1.235	1.247	V
Dropout Voltage (Note 2)	V_{DROP}	$I_O=150mA$		500	850	mV
Line Regulation	ΔV_{LINE}	$I_O=1mA$, $V_{IN}=V_{OUT}+1V$ to 16V		0.03	0.2	%
Load Regulation (Note 3)	ΔV_{LOAD}	$I_O=1mA$ to 150mA		0.1	0.5	%
Output Noise (Note 4)	V_{NOISE}	$C_{OUT} = 1\mu F$, $C_{IN} = 1\mu F$ 10Hz~100kHz		300		μV_{RMS}
Ripple Rejection (Note 4)	PSRR	$V_{IN}=V_{OUT}+1V$, $f_{RIPPLE} = 120Hz$, $C_{OUT} = 1\mu F$		65		dB
Temperature Coefficient (Note 4)	TC	$I_{OUT} = 1mA$, $V_{IN} = 15V$		50		ppm/ $^\circ C$
Thermal Shutdown Threshold (Note4)	T_{SD}			150		$^\circ C$
	ΔT_{SD}	Hysteresis		10		$^\circ C$
\overline{SHDN} Pin Threshold	$V_{\overline{SHDN}(ON)}$	ON	3.0			V
	$V_{\overline{SHDN}(OFF)}$	OFF			0.4	V
\overline{SHDN} Pin Current	$I_{\overline{SHDN}}$				0.1	μA

Note 2 : The dropout voltage is defined as $V_{IN}-V_{OUT}$, which is measured when V_{OUT} drops 2% of its normal value with the specified output current.

Note 3 : Load regulation and dropout voltage are measured at a constant junction temperature by using a 40ms low duty cycle current pulse.

Note 4 : The specification is guaranteed by design, not production tested.

Typical Performance Curves

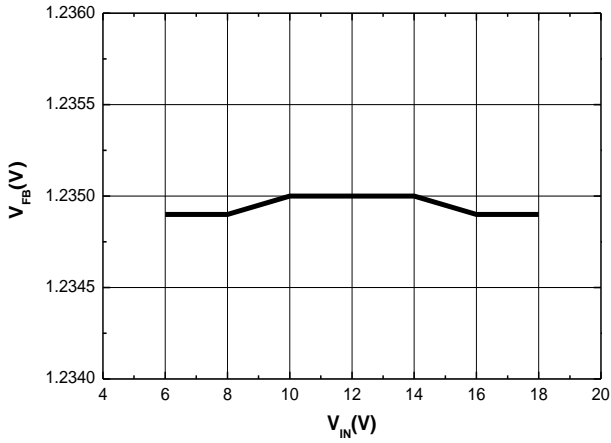

Figure 4. Line Regulation (I_{OUT}=0mA)

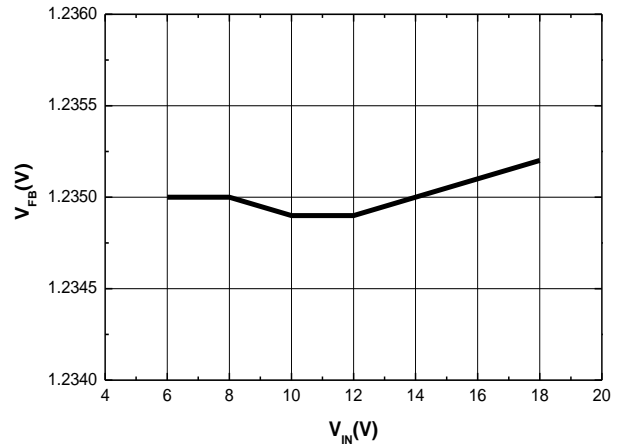

Figure 5. Line Regulation (I_{OUT}=1mA)

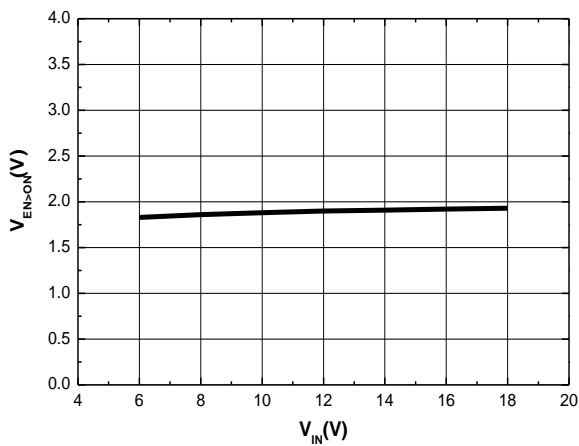

Figure 6. Input Voltage vs. Enable ON

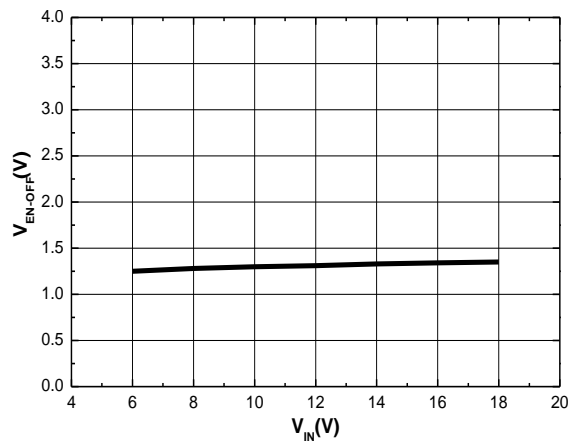

Figure 7. Input Voltage vs. Enable OFF

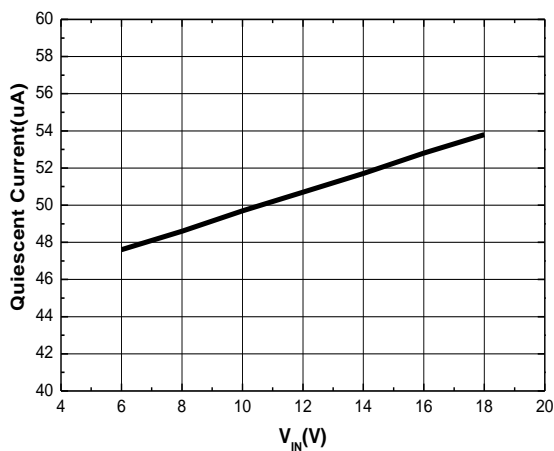

Figure 8. Input Voltage vs. Quiescent Current

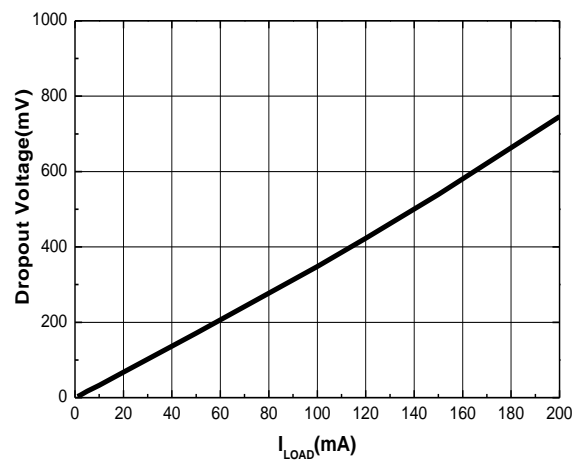

Figure 9. Output Current vs. Dropout Voltage (V_{IN}=12V)

Typical Performance Curves (Continued)

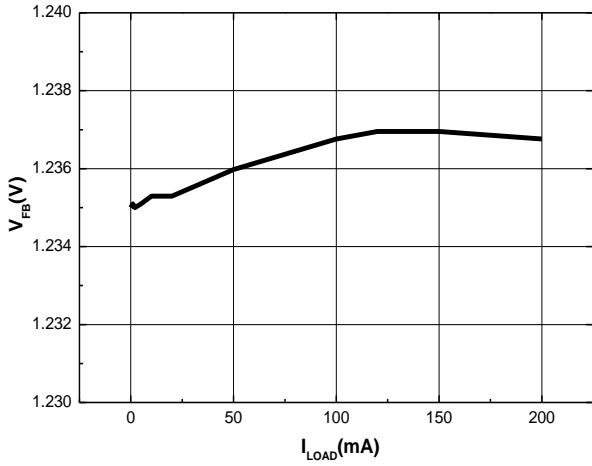

Figure 10. Load Regulation

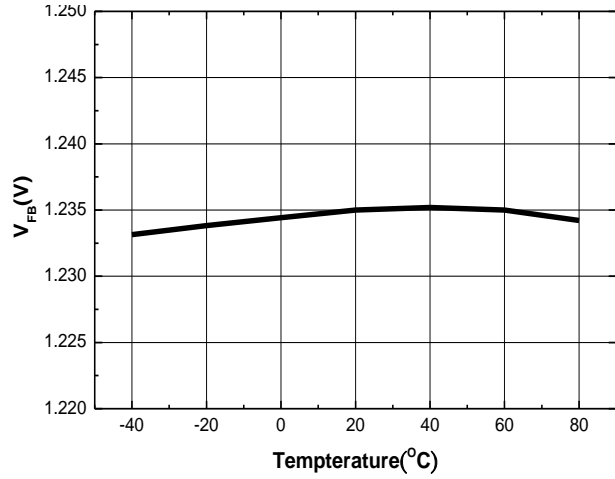

Figure 11. Temperature vs. Feedback voltage

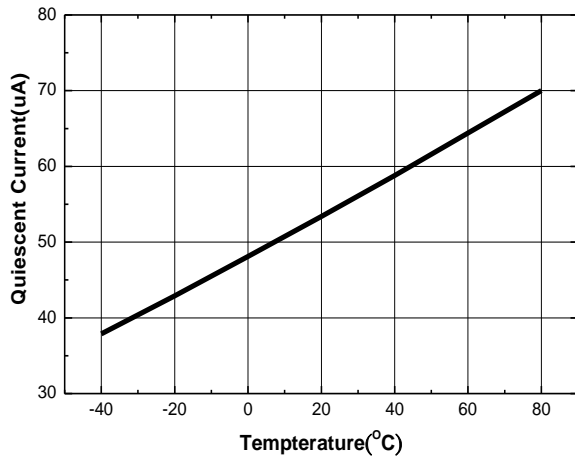

Figure 12. Temperature vs. Quiescent Current

Application Information

The FP6160 is a high voltage, low dropout linear regulator that could provide 150mA output current at 800mV dropout voltage. Besides, current limit and on chip thermal shutdown features provide protection against any combination of overload or ambient temperature that could exceed junction temperature.

Shutdown Control

Force $\overline{\text{SHDN}}$ pin high to enable the FP6160 and turned off the device by pulling it low. The $\overline{\text{SHDN}}$ pin can't be left floating and must be tied to the V_{IN} if not used.

Output Voltage Setting

The output voltage of regulator is determined by connecting external resistor dividers. The external resistor divider connects with FB pin. The output voltage is determined by the following equation:

$$V_{\text{OUT}} = \frac{R1+R2}{R2} \times V_{\text{FB}} = \left(1 + \frac{R1}{R2}\right) \times 1.235$$

PSRR (Power Supply Rejection Ratio)

The FP6160 has high 65dB PSRR. Ripple rejection is the ability of the regulator to reduce input voltage ripple. It is specified with a 120Hz and 1V_{P-P} signal applying to input with a 1μF output capacitor. Ripple rejection, expressed in dB, is the ratio of output ripple to input ripple.

Output and Input Capacitor

The FP6160 is designed to be stable with low ESR ceramic capacitors. Higher values of capacitors and

ESR could improve output stability. So the ESR of output capacitor is very important because it generates a zero to provide phase lead for loop stability. It is recommended to use 1μF to 10μF X5R or X7R dielectric ceramic capacitors with 30mΩ to 50mΩ ESR range between VOUT and GND for transient stability.

Larger value of the output capacitor decreases the peak deviations and improves transition response for larger current changes.

The ESR is not essential for input capacitor, but its voltage and temperature coefficient have to be considered for device application environment.

Over Temperature Protection

Over temperature protection function is integrated in the chip. The thermal protection function prevents the excessive power dissipation from overheating. When the chip temperature is higher than 150°C, the controller will be shutdown. When the junction temperature cools down to a constant value, the thermal protection will be released and the chip will operate normally again.

Thermal Consideration

The power handling capability of the device will be limited by allowable operation junction temperature (125°C). The power dissipated by the device will be estimated by $P_D = I_{\text{OUT}} \times (V_{\text{IN}} - V_{\text{OUT}})$. The power dissipation should be lower than the maximum power dissipation listed in "Absolute Maximum Ratings" section.

Outline Information

SOT-23-5 Package (Unit: mm)

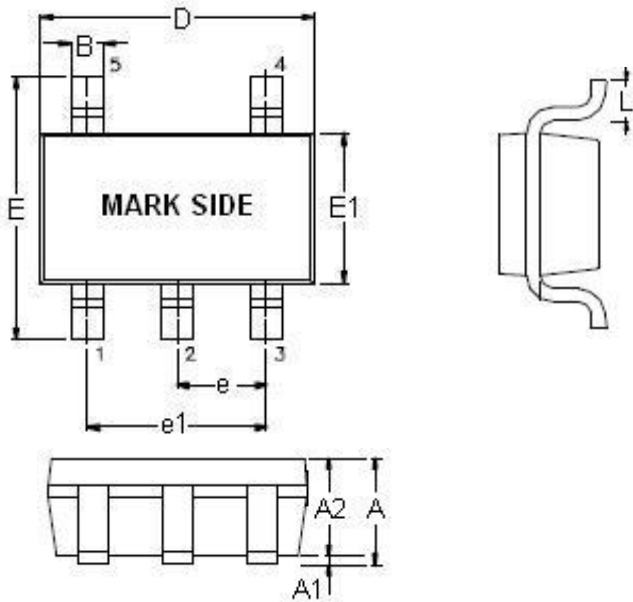

SYMBOLS UNIT	DIMENSION IN MILLIMETER	
	MIN	MAX
A	0.90	1.45
A1	0.00	0.15
A2	0.90	1.30
B	0.30	0.50
D	2.80	3.00
E	2.60	3.00
E1	1.50	1.70
e	0.90	1.00
e1	1.80	2.00
L	0.30	0.60

Note : Followed From JEDEC MO-178-C.

Carrier Dimensions

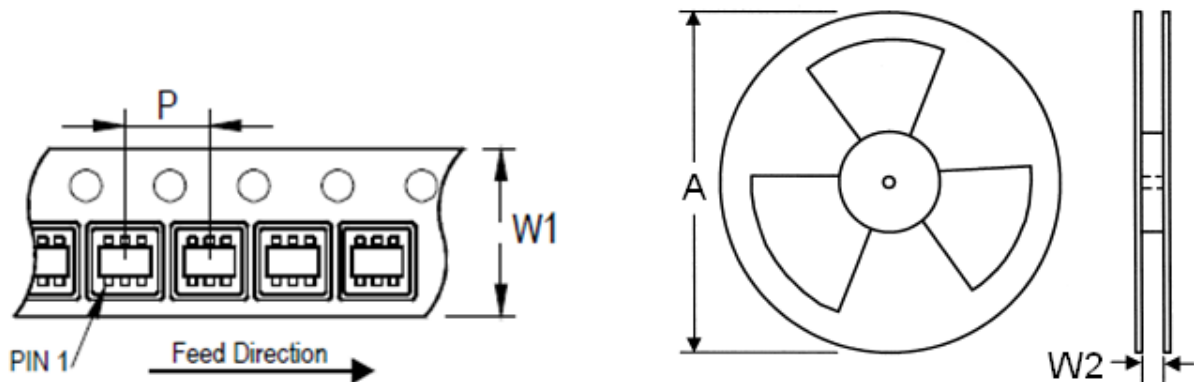

Tape Size (W1) mm	Pocket Pitch (P) mm	Reel Size (A)		Reel Width (W2) mm	Empty Cavity Length mm	Units per Reel
		in	mm			
8	4	7	180	8.4	300~1000	3,000

Outline Information (Continued)

TSOT-23-5 Package (Unit: mm)

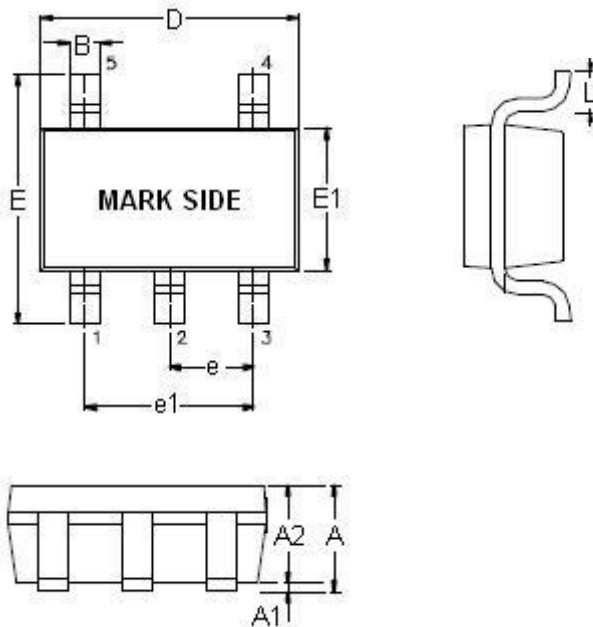

SYMBOLS UNIT	DIMENSION IN MILLIMETER	
	MIN	MAX
A	0.70	0.90
A1	0.00	0.10
A2	0.70	1.00
B	0.30	0.50
D	2.80	3.00
E	2.60	3.00
E1	1.50	1.70
e	0.90	1.00
e1	1.80	2.00
L	0.30	0.60

Carrier Dimensions

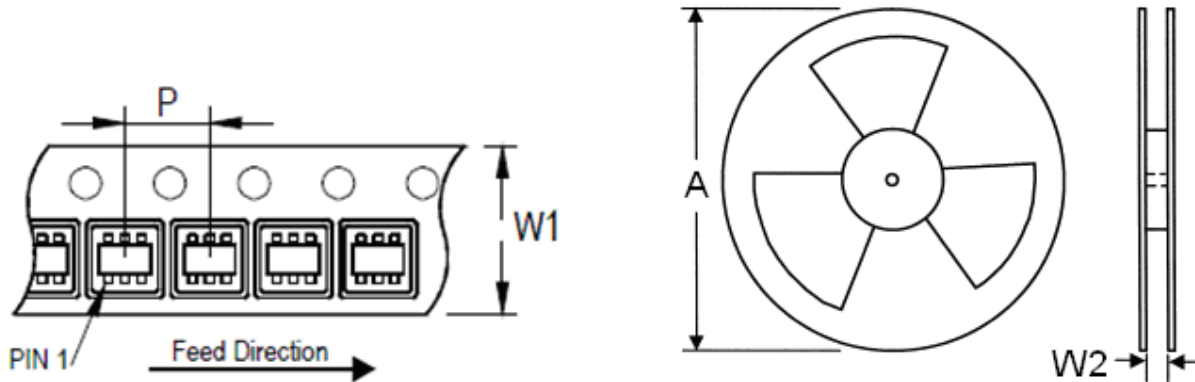

Tape Size (W1) mm	Pocket Pitch (P) mm	Reel Size (A)		Reel Width (W2) mm	Empty Cavity Length mm	Units per Reel
		in	mm			
8	4	7	180	8.4	300~1000	3,000

Life Support Policy

Fitipower's products are not authorized for use as critical components in life support devices or other medical systems.