

SMD AUTO X8G HVHT150C, Ceramic, 0.047 uF, 5%, 630 VDC, X8G, SMD, MLCC, High Voltage, High Temperature, Ultra-Stable, Automotive Grade, 1812

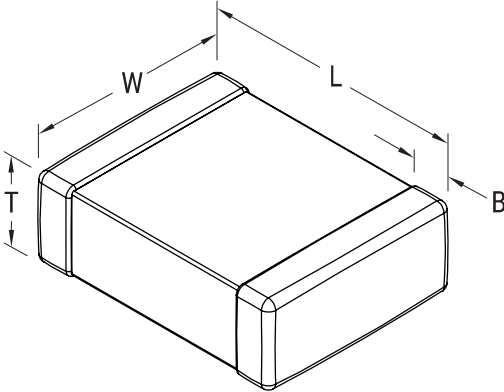

| Dimensions | |
|------------|-----------------|
| Chip Size | 1812 |
| L | 4.5mm +/-0.3mm |
| W | 3.2mm +/-0.3mm |
| T | 2.5mm +/-0.20mm |
| B | 0.6mm +/-0.35mm |

| Packaging Specifications | |
|--------------------------|--------------------------|
| Packaging: | T&R, 180mm, Plastic Tape |
| Packaging Quantity: | 500 |

| General Information | |
|---------------------|---|
| Series: | SMD AUTO X8G HVHT150C |
| Style: | SMD Chip |
| Description: | SMD, MLCC, High Voltage, High Temperature, Ultra-Stable, Automotive Grade |
| Features: | High Temperature, Ultra-Stable, Automotive Grade |
| RoHS: | Yes |
| Termination: | Tin |
| Marking: | No |
| Qualifications: | AEC-Q200 |
| AEC-Q200: | Yes |
| Component Weight: | 87 mg |
| Shelf Life: | 78 Weeks |
| MSL: | 1 |

| Specifications | |
|---|---|
| Capacitance: | 0.047 uF |
| Measurement Condition: | 1 kHz 1.0Vrms |
| Capacitance Tolerance: | 5% |
| Voltage DC: | 630 VDC |
| Dielectric Withstanding Voltage: | 1575 VDC |
| Temperature Range: | -55/+150°C |
| Temperature Coefficient: | X8G |
| Capacitance Change with Reference to +25°C and 0 VDC Applied (TCC): | 30 ppm/C, 1kHz 1.0Vrms |
| Dissipation Factor: | 0.1% 1 kHz 1.0Vrms |
| Aging Rate: | 0% Loss/Decade Hour: Referee Time is 1000 Hours |
| Insulation Resistance: | 21.2766 GOhms |

Statements of suitability for certain applications are based on our knowledge of typical operating conditions for such applications, but are not intended to constitute - and we specifically disclaim - any warranty concerning suitability for a specific customer application or use. This Information is intended for use only by customers who have the requisite experience and capability to determine the correct products for their application. Any technical advice inferred from this Information or otherwise provided by us with reference to the use of our products is given gratis, and we assume no obligation or liability for the advice given or results obtained.