

Low Vcesat PNP Epitaxial Planar Transistor

BTB772NUT3

BV_{CEO}	-30V
I_C	-3A

Features

- Low $V_{CE(sat)}$, typically -0.2 V at $I_C / I_B = -2A / -0.2A$
- Excellent current gain characteristics
- Complementary to BTD882NUT3
- Pb-free lead plating and halogen-free package

Symbol

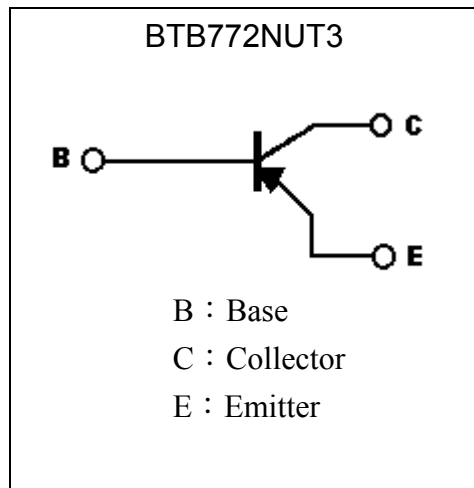

Outline

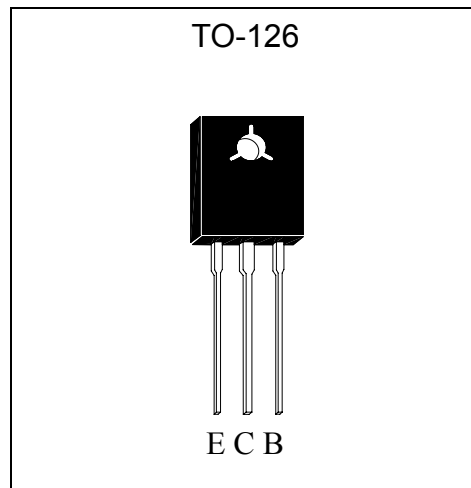

Ordering Information

Device	Package	Shipping
BTB772NUT3-X-BL-X	TO-126 (Pb-free lead plating package)	200 pcs / bag, 3,000 pcs/box , 30,000 pcs/carton

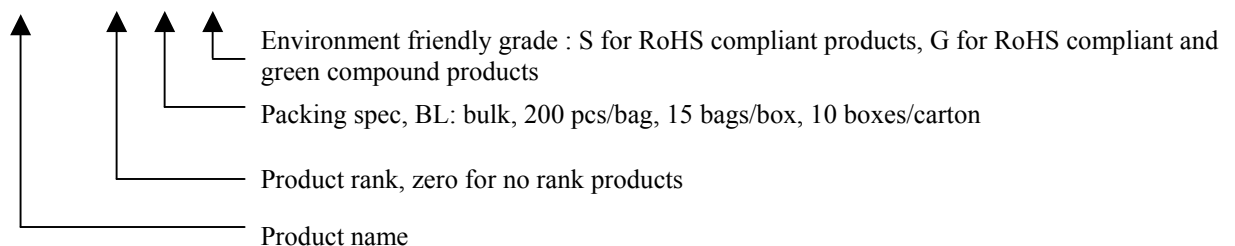

**Absolute Maximum Ratings** (Ta=25°C)

Parameter	Symbol	Limit	Unit
Collector-Base Voltage	V _{CB0}	-40	V
Collector-Emitter Voltage	V _{CEO}	-30	V
Emitter-Base Voltage	V _{EBO}	-12	V
Collector Current	I _C	DC	-3
		Pulse	-7 *1
Power Dissipation	P _D	Ta=25°C	1
		Tc=25°C	10
Operating Junction and Storage Temperature Range	T _j ; T _{stg}	-55~+150	°C

Note : *1. Single Pulse Pw ≤ 300μs, Duty ≤ 2%.

Thermal Performance

Parameter	Symbol	Limit	Unit
Thermal Resistance, Junction-to-Ambient, max	R _{θJA}	125	°C/W
Thermal Resistance, Junction-to-Case, max	R _{θJC}	12.5	

Characteristics (Ta=25°C)

Symbol	Min.	Typ.	Max.	Unit	Test Conditions
BV _{CB0}	-40	-	-	V	I _C =-50μA, I _E =0
BV _{CEO}	-30	-	-	V	I _C =-1mA, I _B =0
BV _{EBO}	-12	-	-	V	I _E =-50μA, I _C =0
I _{CB0}	-	-	-100	nA	V _{CB} =-30V, I _E =0
I _{EBO}	-	-	-100	nA	V _{EB} =-12V, I _C =0
*V _{CE(sat)}	-	-0.2	-0.5	V	I _C =-2A, I _B =-0.2A
*V _{BE(sat)}	-	-1	-1.5	V	I _C =-2A, I _B =-0.2A
*h _{FE 1}	120	-	-	-	V _{CE} =-2V, I _C =-20mA
*h _{FE 2}	160	-	320	-	V _{CE} =-2V, I _C =-500mA
f _T	-	80	-	MHz	V _{CE} =-5V, I _E =-0.1A, f=100MHz
Cob	-	55	-	pF	V _{CB} =-10V, f=1MHz

*Pulse Test : Pulse Width ≤ 380μs, Duty Cycle ≤ 2%

Classification Of h_{FE 2}

Rank	P
Range	180~390



Typical Characteristics



Typical Characteristics(Cont.)

Power Derating Curve

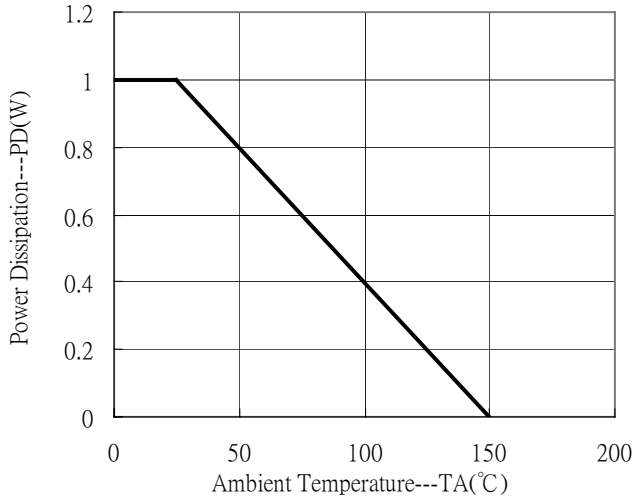

Power Derating Curve

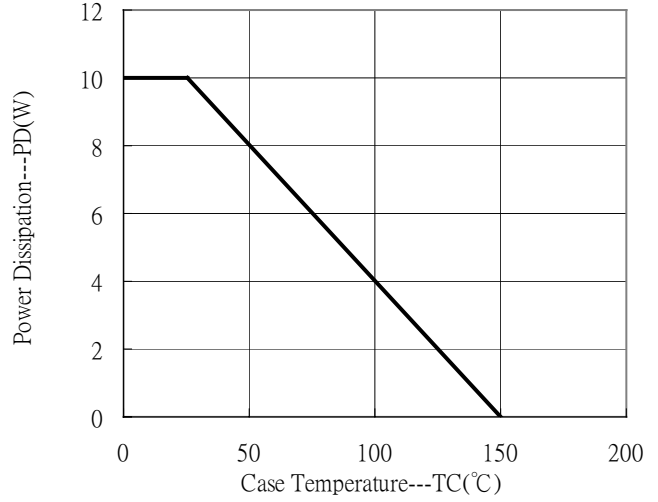

Recommended wave soldering condition

Product	Peak Temperature	Soldering Time
Pb-free devices	260 +0/-5 °C	5 +1/-1 seconds

Recommended temperature profile for IR reflow

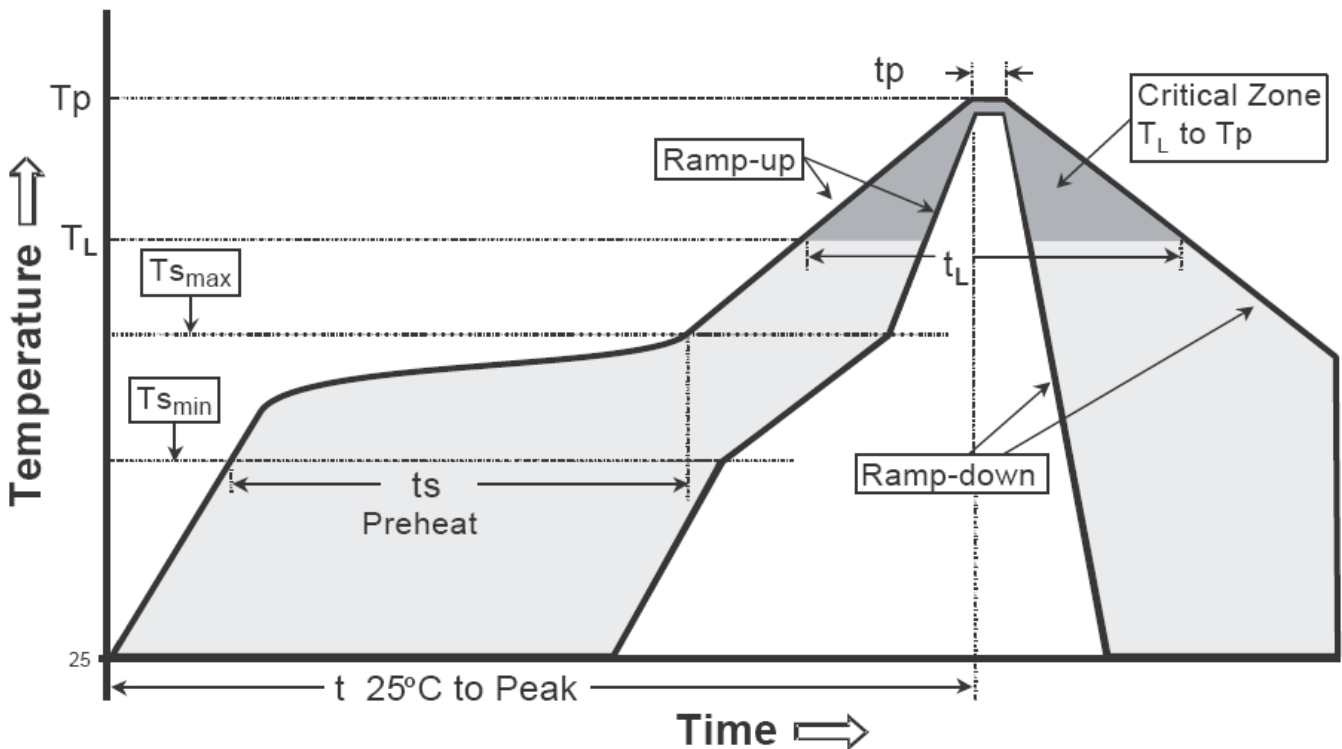

Profile feature	Sn-Pb eutectic Assembly	Pb-free Assembly
Average ramp-up rate (T _{smax} to T _p)	3°C/second max.	3°C/second max.
Preheat		
-Temperature Min(T _{s min})	100°C	150°C
-Temperature Max(T _{s max})	150°C	200°C
-Time(t _{s min} to t _{s max})	60-120 seconds	60-180 seconds
Time maintained above:		
-Temperature (T _L)	183°C	217°C
- Time (t _L)	60-150 seconds	60-150 seconds
Peak Temperature(T _p)	240 +0/-5 °C	260 +0/-5 °C
Time within 5°C of actual peak temperature(tp)	10-30 seconds	20-40 seconds
Ramp down rate	6°C/second max.	6°C/second max.
Time 25 °C to peak temperature	6 minutes max.	8 minutes max.

Note : All temperatures refer to topside of the package, measured on the package body surface.

TO-126 Dimension

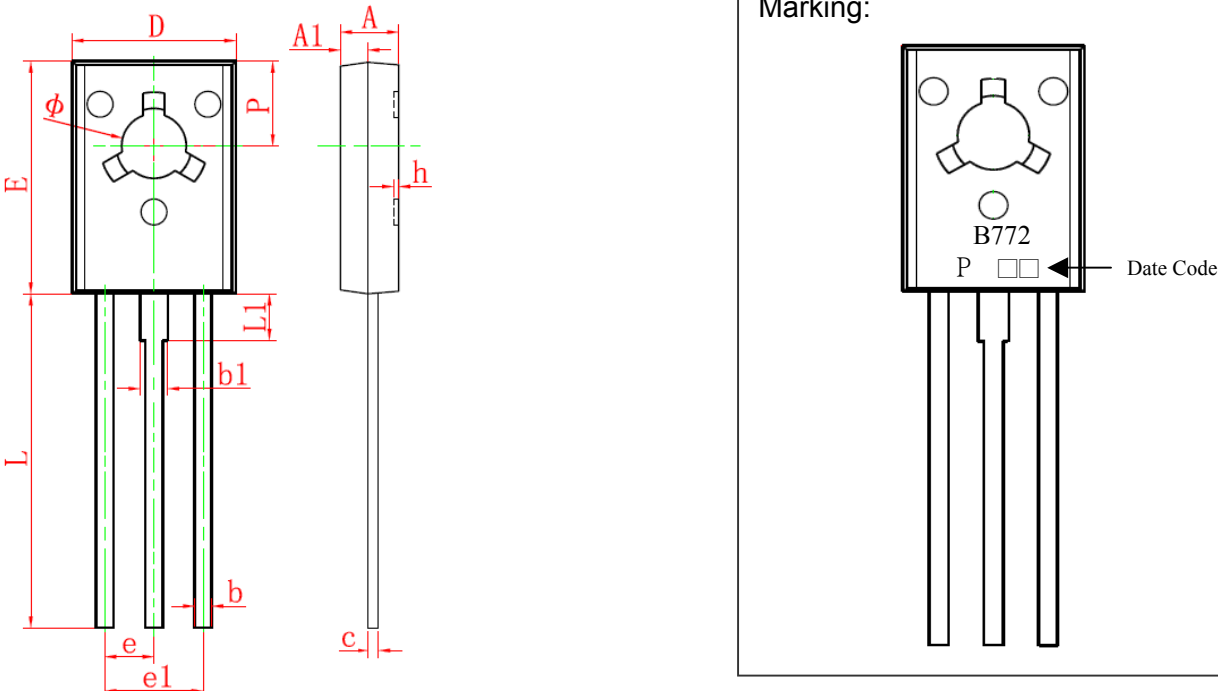

Marking:

Style: Pin 1. Emitter 2. Collector 3. Base

3-Lead TO-126 Plastic Package
 CYStek Package Code: T3

*: Typical

DIM	Millimeters		Inches		DIM	Millimeters		Inches	
	Min.	Max.	Min.	Max.		Min.	Max.	Min.	Max.
A	2.500	2.900	0.098	0.114	e	*2.290		*0.090	
A1	1.100	1.500	0.043	0.059	e1	4.480	4.680	0.176	0.184
b	0.660	0.860	0.026	0.034	h	0.000	0.300	0.000	0.012
b1	1.170	1.370	0.046	0.054	L	15.300	15.700	0.602	0.618
c	0.450	0.600	0.018	0.024	L1	2.100	2.300	0.083	0.091
D	7.400	7.800	0.291	0.307	P	3.900	4.100	0.154	0.161
E	10.600	11.000	0.417	0.433	Φ	3.000	3.200	0.118	0.126

Notes: 1. Controlling dimension: millimeters.
 2. Maximum lead thickness includes lead finish thickness, and minimum lead thickness is the minimum thickness of base material.
 3. If there is any question with packing specification or packing method, please contact your local CYStek sales office.

Material:

- Lead: Pure tin plated.
- Mold Compound: Epoxy resin family, flammability solid burning class: UL94V-0.

Important Notice:

- All rights are reserved. Reproduction in whole or in part is prohibited without the prior written approval of CYStek.
- CYStek reserves the right to make changes to its products without notice.
- CYStek **semiconductor products are not warranted to be suitable for use in Life-Support Applications, or systems.**
- CYStek assumes no liability for any consequence of customer product design, infringement of patents, or application assistance.